

具有可配置电压转换、三态输出和总线保持电路的 SN74AXCH8T245 8 位双电源总线收发器

1 特性

- 通过认证且完全可配置的双电源轨设计可允许各个端口在 0.65V 至 3.6V 的电源电压范围内运行
- 工作温度范围 -40°C 至 +125°C
- 总线保持数据输入消除了对外部上拉或下拉电阻的需求
- 多向控制引脚，支持同步升降转换
- 从 1.8V 转换到 3.3V 时，支持高达 380Mbps 的转换速率
- V_{CC} 隔离功能可在断电情况下有效隔离两条总线
- 局部断电模式可在断电情况下限制回流电流
- 兼容 SN74AVCH8T245 和 74AVCH8T245 电平转换器
- 闩锁性能超出 JESD 78 II 类规范要求的 100mA
- 静电放电 (ESD) 保护性能超过 JESD 22 规范的要求
 - 8000V 人体放电模型
 - 1000V 充电器件模型

2 应用

- 企业与通信
- 无线基础设施
- 楼宇自动化
- 数据中心交换机
- 企业级固态硬盘
- 机架式服务器
- 电子销售点 (EPOS)

3 说明

SN74AXCH8T245 器件是一款 8 位同相总线收发器，可用于解决在最新电压节点 (0.7V、0.8V、0.9V) 上运行的器件与在行业标准电压节点 (1.8V、2.5V、3.3V) 上运行的器件之间的电压电平不匹配问题。

该器件通过两条独立电源轨 (V_{CCA} 和 V_{CCB})。数据引脚 A1 至 A8 均用于跟踪 V_{CCA}，可承受 0.65V-3.6V 范围内的任何电源电压。数据引脚 B1 至 B8 均用于跟踪 V_{CCB}，可承受 0.65V-3.6V 范围内的任何电源电压。此外，SN74AXCH8T245 还与单电源系统兼容。

SN74AXCH8T245 器件旨在实现数据总线间的异步通信。根据方向控制输入 (DIR1 和 DIR2) 的逻辑电平，此器件将数据从 A 总线传输至 B 总线，或者将数据从 B 总线传输至 A 总线。输出使能 (\overline{OE}) 输入可用于禁用输出，从而有效隔离总线。

SN74AXCH8T245 器件旨在使控制引脚 (DIR 和 \overline{OE}) 以 V_{CCA} 为基准。

有源总线保持电路会将未使用或未驱动的输入保持在有效逻辑状态。不建议在总线保持电路上使用上拉或下拉电阻器。如果 V_{CCA} 或 V_{CCB} 连上电源，则总线保持电路在所有 A 端口和 B 端口上均始终保持工作状态，与方向控制或输出使能无关。

该器件完全适用于使用 I_{off} 的不完全断电应用。当器件断电时，I_{off} 电路将会禁用输出。这会抑制电流反流到器件中，从而防止损坏器件。

V_{CC} 隔离功能可确保当任一 V_{CC} 输入电源低于 100mV 时，所有电平转换器输出都将禁用并处于高阻抗状态。为了确保电平转换器 I/O 在上电或掉电期间处于高阻抗状态，应将 \overline{OE} 通过上拉电阻器接到 V_{CCA}；该电阻器的最小值取决于驱动器的灌电流能力。

器件信息⁽¹⁾

器件编号	封装	封装尺寸 (标称值)
SN74AXCH8T245PW	TSSOP (24)	7.80mm × 4.40mm
SN74AXCH8T245RHL	VQFN (24)	5.50mm × 3.50mm

(1) 如需了解所有可用封装，请参阅产品说明书末尾的可订购产品附录。

典型应用原理图

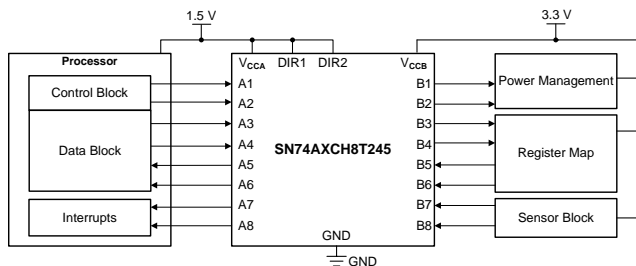

目录

1	特性	1	8	Detailed Description	20
2	应用	1	8.1	Overview	20
3	说明	1	8.2	Functional Block Diagram	20
4	修订历史记录	2	8.3	Feature Description	21
5	Pin Configuration and Functions	3	8.4	Device Functional Modes	21
6	Specifications	4	9	Application and Implementation	22
6.1	Absolute Maximum Ratings	4	9.1	Application Information	22
6.2	ESD Ratings	4	9.2	Typical Application	22
6.3	Recommended Operating Conditions	5	10	Power Supply Recommendations	24
6.4	Thermal Information	5	11	Layout	24
6.5	Electrical Characteristics	6	11.1	Layout Guidelines	24
6.6	Switching Characteristics, $V_{CCA} = 0.7\text{ V}$	8	11.2	Layout Example	24
6.7	Switching Characteristics, $V_{CCA} = 0.8\text{ V}$	9	12	器件和文档支持	25
6.8	Switching Characteristics, $V_{CCA} = 0.9\text{ V}$	10	12.1	文档支持	25
6.9	Switching Characteristics, $V_{CCA} = 1.2\text{ V}$	11	12.2	接收文档更新通知	25
6.10	Switching Characteristics, $V_{CCA} = 1.5\text{ V}$	12	12.3	社区资源	25
6.11	Switching Characteristics, $V_{CCA} = 1.8\text{ V}$	13	12.4	商标	25
6.12	Switching Characteristics, $V_{CCA} = 2.5\text{ V}$	14	12.5	静电放电警告	25
6.13	Switching Characteristics, $V_{CCA} = 3.3\text{ V}$	15	12.6	术语表	25
6.14	Operating Characteristics: $T_A = 25^\circ\text{C}$	16	13	机械、封装和可订购信息	26
7	Parameter Measurement Information	18			

4 修订历史记录

Changes from Original (August 2018) to Revision A

Page

• 已添加 向器件信息表添加了 RHL 封装	1
• Added RHL package pinout	3
• Added RHL package to Thermal Information table	5

5 Pin Configuration and Functions

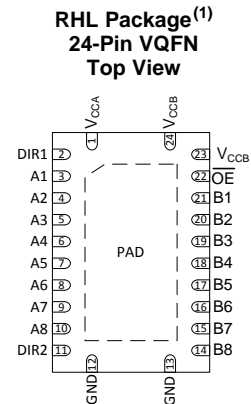
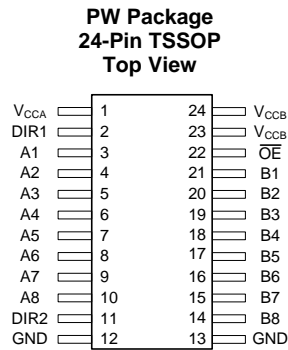

(1) PAD - may be grounded (recommended) or left floating.

Pin Functions

PIN		I/O	DESCRIPTION
NAME	PW, RHL		
A1	3	I/O	Input/output A1. Referenced to V _{CCA} .
A2	4	I/O	Input/output A2. Referenced to V _{CCA} .
A3	5	I/O	Input/output A3. Referenced to V _{CCA} .
A4	6	I/O	Input/output A4. Referenced to V _{CCA} .
A5	7	I/O	Input/output A5. Referenced to V _{CCA} .
A6	8	I/O	Input/output A6. Referenced to V _{CCA} .
A7	9	I/O	Input/output A7. Referenced to V _{CCA} .
A8	10	I/O	Input/output A8. Referenced to V _{CCA} .
B1	21	I/O	Input/output B1. Referenced to V _{CCB} .
B2	20	I/O	Input/output B2. Referenced to V _{CCB} .
B3	19	I/O	Input/output B3. Referenced to V _{CCB} .
B4	18	I/O	Input/output B4. Referenced to V _{CCB} .
B5	17	I/O	Input/output B5. Referenced to V _{CCB} .
B6	16	I/O	Input/output B6. Referenced to V _{CCB} .
B7	15	I/O	Input/output B7. Referenced to V _{CCB} .
B8	14	I/O	Input/output B8. Referenced to V _{CCB} .
DIR1	2	I	Direction-control signal. Referenced to V _{CCA} .
DIR2	11	I	Direction-control signal. Referenced to V _{CCA} . See Multiple Direction Control Pins for additional details. Tie to GND to maintain backwards compatibility with the SN74AVCH8T245 device.
GND	12	—	Ground
	13	—	Ground
OE	22	I	Output Enable. Pull to GND to enable all outputs. Pull to V _{CCA} to place all outputs in high-impedance mode. Referenced to V _{CCA} .
V _{CCA}	1	—	A-port supply voltage. 0.65 V ≤ V _{CCA} ≤ 3.6 V
V _{CCB}	23	—	B-port supply voltage. 0.65 V ≤ V _{CCB} ≤ 3.6 V
	24	—	B-port supply voltage. 0.65 V ≤ V _{CCB} ≤ 3.6 V

6 Specifications

6.1 Absolute Maximum Ratings

 over operating free-air temperature range (unless otherwise noted)⁽¹⁾

		MIN	MAX	UNIT
Supply voltage, V_{CCA}		-0.5	4.2	V
Supply voltage, V_{CCB}		-0.5	4.2	V
Input voltage, V_I ⁽²⁾	I/O ports (A port)	-0.5	4.2	V
	I/O ports (B port)	-0.5	4.2	
	Control inputs	-0.5	4.2	
Voltage applied to any output in the high-impedance or power-off state, V_O ⁽²⁾	A port	-0.5	4.2	V
	B port	-0.5	4.2	
Voltage applied to any output in the high or low state, V_O ^{(2) (3)}	A port	-0.5	$V_{CCA} + 0.2$	V
	B port	-0.5	$V_{CCB} + 0.2$	
Input clamp current, I_{IK}	$V_I < 0$	-50		mA
Output clamp current, I_{OK}	$V_O < 0$	-50		mA
Continuous output current, I_O		-50	50	mA
Continuous current through V_{CCA} , V_{CCB} , or GND		-100	100	mA
Junction Temperature, T_J			150	°C
Storage temperature, T_{stg}		-65	150	°C

- (1) Stresses beyond those listed under *Absolute Maximum Ratings* may cause permanent damage to the device. These are stress ratings only, which do not imply functional operation of the device at these or any other conditions beyond those indicated under *Recommended Operating Conditions*. Exposure to absolute-maximum-rated conditions for extended periods may affect device reliability.
- (2) The input voltage and output negative-voltage ratings may be exceeded if the input and output current ratings are observed.
- (3) The output positive-voltage rating may be exceeded up to 4.2 V maximum if the output current rating is observed.

6.2 ESD Ratings

		VALUE	UNIT
$V_{(ESD)}$ Electrostatic discharge	Human-body model (HBM), per ANSI/ESDA/JEDEC JS-001 ⁽¹⁾	±8000	V
	Charged-device model (CDM), per JEDEC specification JESD22-C101 ⁽²⁾	±1000	

- (1) JEDEC document JEP155 states that 500-V HBM allows safe manufacturing with a standard ESD control process.
- (2) JEDEC document JEP157 states that 250-V CDM allows safe manufacturing with a standard ESD control process.

6.3 Recommended Operating Conditions

over operating free-air temperature range (unless otherwise noted) ⁽¹⁾⁽²⁾⁽³⁾

		MIN	MAX	UNIT	
V _{CCA}	Supply voltage	0.65	3.6	V	
V _{CCB}	Supply voltage	0.65	3.6	V	
V _{IH}	High-level input voltage	Data inputs	V _{CCI} = 0.65 V - 0.75 V	V _{CCI} × 0.70	V
			V _{CCI} = 0.76 V - 1 V	V _{CCI} × 0.70	
			V _{CCI} = 1.1 V - 1.95 V	V _{CCI} × 0.65	
			V _{CCI} = 2.3 V - 2.7 V	1.6	
			V _{CCI} = 3 V - 3.6 V	2	
	Control inputs (DIR, \overline{OE}) Referenced to V _{CCA}	V _{CCA} = 0.65 V - 0.75 V	V _{CCA} × 0.70		
		V _{CCA} = 0.76 V - 1 V	V _{CCA} × 0.70		
		V _{CCA} = 1.1 V - 1.95 V	V _{CCA} × 0.65		
		V _{CCA} = 2.3 V - 2.7 V	1.6		
		V _{CCA} = 3 V - 3.6 V	2		
V _{IL}	Low-level input voltage	Data inputs	V _{CCI} = 0.65 V - 0.75 V	V _{CCI} × 0.30	V
			V _{CCI} = 0.76 V - 1 V	V _{CCI} × 0.30	
			V _{CCI} = 1.1 V - 1.95 V	V _{CCI} × 0.35	
			V _{CCI} = 2.3 V - 2.7 V	0.7	
			V _{CCI} = 3 V - 3.6 V	0.8	
	Control inputs (DIR, \overline{OE}) Referenced to V _{CCA}	V _{CCA} = 0.65 V - 0.75 V	V _{CCA} × 0.30		
		V _{CCA} = 0.76 V - 1 V	V _{CCA} × 0.30		
		V _{CCA} = 1.1 V - 1.95 V	V _{CCA} × 0.35		
		V _{CCA} = 2.3 V - 2.7 V	0.7		
		V _{CCA} = 3 V - 3.6 V	0.8		
V _I	Input voltage ⁽³⁾	0	3.6	V	
V _O	Output voltage	Active state	0	V _{CCO} ⁽²⁾	V
		Tri-state	0	3.6	
$\Delta t/\Delta v$	Input transition rise or fall rate		10	ns/V	
T _A	Operating free-air temperature	-40	125	°C	

(1) V_{CCI} is the V_{CC} associated with the input port.

(2) V_{CCO} is the V_{CC} associated with the output port.

(3) All unused data inputs of the device must be held at V_{CCI} or GND to ensure proper device operation. See the [Implications of Slow or Floating CMOS Inputs](#) application report.

6.4 Thermal Information

THERMAL METRIC ⁽¹⁾	SN74AXCH8T245		UNIT	
	PW (TSSOP)	RHL (VQFN)		
	24 PINS	24 PINS		
R _{θJA}	Junction-to-ambient thermal resistance	101.7	35	°C/W
R _{θJC(top)}	Junction-to-case (top) thermal resistance	45.4	39.9	°C/W
R _{θJB}	Junction-to-board thermal resistance	56.9	13.8	°C/W
ψ _{JT}	Junction-to-top characterization parameter	7.0	0.3	°C/W
ψ _{JB}	Junction-to-board characterization parameter	56.4	13.8	°C/W
R _{θJC(bot)}	Junction-to-case (bottom) thermal resistance	N/A	1.4	°C/W

(1) For more information about traditional and new thermal metrics, see the [Semiconductor and IC Package Thermal Metrics](#) application report.

6.5 Electrical Characteristics

 Over recommended operating free-air temperature range (unless otherwise noted)⁽¹⁾

PARAMETER	TEST CONDITIONS		V _{CCA}	V _{CCB}	–40°C to 85°C			–40°C to 125°C			UNIT
					MIN	TYP ⁽²⁾	MAX	MIN	TYP ⁽²⁾	MAX	
V _{OH} High-level output voltage	V _I = V _{IH}	I _{OH} = –100 μA	0.7 V - 3.6 V	0.7 V - 3.6 V	V _{CCO} – 0.1			V _{CCO} – 0.1			V
		I _{OH} = –50 μA	0.65 V	0.65 V	0.55			0.55			
		I _{OH} = –200 μA	0.76 V	0.76 V	0.58			0.58			
		I _{OH} = –500 μA	0.85 V	0.85 V	0.65			0.65			
		I _{OH} = –3 mA	1.1 V	1.1 V	0.85			0.85			
		I _{OH} = –6 mA	1.4 V	1.4 V	1.05			1.05			
		I _{OH} = –8 mA	1.65 V	1.65 V	1.2			1.2			
		I _{OH} = –9 mA	2.3 V	2.3 V	1.75			1.75			
		I _{OH} = –12 mA	3 V	3 V	2.3			2.3			
V _{OL} Low-level output voltage	V _I = V _{IL}	I _{OL} = 100 μA	0.7 V - 3.6 V	0.7 V - 3.6 V							V
		I _{OL} = 50 μA	0.65 V	0.65 V							
		I _{OL} = 200 μA	0.76 V	0.76 V							
		I _{OL} = 500 μA	0.85 V	0.85 V							
		I _{OL} = 3 mA	1.1 V	1.1 V							
		I _{OL} = 6 mA	1.4 V	1.4 V							
		I _{OL} = 8 mA	1.65 V	1.65 V							
		I _{OL} = 9 mA	2.3 V	2.3 V							
		I _{OL} = 12 mA	3 V	3 V							
I _{BHL} Bus-hold low sustaining current ⁽³⁾	V _I = 0.20 V		0.65 V	0.65 V	4			4			μA
	V _I = 0.23 V		0.76 V	0.76 V	8			7			
	V _I = 0.26 V		0.85 V	0.85 V	10			10			
	V _I = 0.39 V		1.1 V	1.1 V	20			20			
	V _I = 0.49 V		1.4 V	1.4 V	40			30			
	V _I = 0.58 V		1.65 V	1.65 V	55			45			
	V _I = 0.7 V		2.3 V	2.3 V	90			80			
	V _I = 0.8 V		3 V	3 V	145			135			
I _{BHH} Bus-hold high sustaining current ⁽⁴⁾	V _I = 0.45 V		0.65 V	0.65 V	–4			–4			μA
	V _I = 0.53 V		0.76 V	0.76 V	–8			–7			
	V _I = 0.59 V		0.85 V	0.85 V	–10			–10			
	V _I = 0.71 V		1.1 V	1.1 V	–20			–20			
	V _I = 0.91 V		1.4 V	1.4 V	–40			–30			
	V _I = 1.07 V		1.65 V	1.65 V	–55			–45			
	V _I = 1.6 V		2.3 V	2.3 V	–90			–80			
	V _I = 2.0 V		3 V	3 V	–145			–135			
I _{BHLO} Bus-hold low overdrive current ⁽⁵⁾	V _I = 0 to V _{CC}		0.75 V	0.75 V	40			40			μA
			0.84 V	0.84 V	50			50			
			0.95 V	0.95 V	65			65			
			1.3 V	1.3 V	105			105			
			1.6 V	1.6 V	150			150			
			1.95 V	1.95 V	205			205			
			2.7 V	2.7 V	335			335			
			3.6V	3.6V	480			480			

(1) V_{CCO} is the V_{CC} associated with the output port.

(2) All typical values are for T_A = 25°C.

(3) The bus-hold circuit can sink at least the minimum low sustaining current at V_{IL}(MAX). I_{BHL} should be measured after lowering V_I to GND and then raising it to V_{IL}(MAX).

(4) The bus-hold circuit can source at least the minimum high sustaining current at V_{IH}(MIN). I_{BHH} should be measured after raising V_I to V_{CC} and then lowering it to V_{IH}(MIN).

(5) An external driver must source at least I_{BHLO} to switch this node from low to high.

Electrical Characteristics (continued)

Over recommended operating free-air temperature range (unless otherwise noted)⁽¹⁾

PARAMETER	TEST CONDITIONS	V _{CCA}	V _{CCB}	–40°C to 85°C			–40°C to 125°C			UNIT
				MIN	TYP ⁽²⁾	MAX	MIN	TYP ⁽²⁾	MAX	
I _{BHHO}	Bus-hold high overdrive current ⁽⁶⁾ V _I = 0 to V _{CC}	0.75 V	0.75 V	–40			–40			μA
		0.84 V	0.84 V	–50			–50			
		0.95 V	0.95 V	–65			–65			
		1.3 V	1.3 V	–105			–105			
		1.6 V	1.6 V	–150			–150			
		1.95 V	1.95 V	–205			–205			
		2.7 V	2.7 V	–335			–335			
		3.6V	3.6V	–480			–480			
I _I	Input leakage current Control Inputs (DIR, \overline{OE}): V _I = V _{CCA} or GND	0.65 V - 3.6 V	0.65 V - 3.6 V	–0.5		0.5	–1		1	μA
I _{off}	Partial power down current A Port: V _I or V _O = 0 V - 3.6 V	0 V	0 V - 3.6 V	–8		8	–12		12	μA
	B Port: V _I or V _O = 0 V - 3.6 V	0 V - 3.6 V	0 V	–8		8	–12		12	
I _{OZ}	High-impedance state output current A Port: V _O = V _{CCO} or GND, V _I = V _{CCI} or GND, \overline{OE} = V _{IH}	3.6 V	3.6 V	–8		8	–12		12	μA
	B Port: V _O = V _{CCO} or GND, V _I = V _{CCI} or GND, \overline{OE} = V _{IH}	3.6 V	3.6 V	–8		8	–12		12	
I _{CCA}	V _{CCA} supply current V _I = V _{CCI} or GND, I _O = 0 mA	0.65 V - 3.6 V	0.65 V - 3.6 V			20			42	μA
		0 V	3.6 V	–2			–12			
		3.6 V	0 V			13			27	
I _{CCB}	V _{CCB} supply current V _I = V _{CCI} or GND, I _O = 0 mA	0.65 V - 3.6 V	0.65 V - 3.6 V			20			40	μA
		0 V	3.6 V			13			27	
		3.6 V	0 V	–2			–12			
I _{CCA} + I _{CCB}	Combined supply current V _I = V _{CCI} or GND, I _O = 0 mA	0.65 V - 3.6 V	0.65 V - 3.6 V			30			60	μA
C _i	Input capacitance Control Inputs (DIR, \overline{OE}): V _I = 3.3 V or GND	3.3 V	3.3 V		4.5			4.5		pF
C _{io}	Data I/O capacitance Ports A and B: \overline{OE} = V _{CCA} , V _O = 1.65V DC + 1 MHz -16 dBm sine wave	3.3 V	3.3 V		7.3			7.3		pF

(6) An external driver must sink at least I_{BHHO} to switch this node from high to low.

6.6 Switching Characteristics, $V_{CCA} = 0.7\text{ V}$

See Figure 1 and Figure 2 for test circuit and loading conditions. See Figure 3 and Figure 4 for measurement waveforms.

PARAMETER		TEST CONDITION	B-PORT SUPPLY VOLTAGE (V_{CCB})								UNIT	
			0.7 V ± 0.05 V		0.8 V ± 0.04 V		0.9 V ± 0.045 V		1.2 V ± 0.1 V			
			MIN	MAX	MIN	MAX	MIN	MAX	MIN	MAX		
t_{pd}	Propagation delay	A input to B output	–40°C to 85°C	0.5	178	0.5	115	0.5	83	0.5	49	ns
			–40°C to 125°C	0.5	178	0.5	115	0.5	83	0.5	49	
	B input to A output	–40°C to 85°C	0.5	178	0.5	159	0.5	132	0.5	94		
		–40°C to 125°C	0.5	178	0.5	159	0.5	132	0.5	94		
t_{dis}	Disable time	\overline{OE} input to A output	–40°C to 85°C	0.5	194	0.5	194	0.5	194	0.5	194	ns
			–40°C to 125°C	0.5	194	0.5	194	0.5	194	0.5	194	
	\overline{OE} input to B output	–40°C to 85°C	0.5	216	0.5	179	0.5	158	0.5	78		
		–40°C to 125°C	0.5	216	0.5	179	0.5	158	0.5	78		
t_{en}	Enable time	\overline{OE} input to A output	–40°C to 85°C	0.5	240	0.5	240	0.5	240	0.5	240	ns
			–40°C to 125°C	0.5	240	0.5	240	0.5	240	0.5	240	
	\overline{OE} input to B output	–40°C to 85°C	0.5	292	0.5	180	0.5	125	0.5	76		
		–40°C to 125°C	0.5	292	0.5	180	0.5	125	0.5	76		

PARAMETER		TEST CONDITION	B-PORT SUPPLY VOLTAGE (V_{CCB})								UNIT	
			1.5 V ± 0.1 V		1.8 V ± 0.15 V		2.5 V ± 0.2 V		3.3 V ± 0.3 V			
			MIN	MAX	MIN	MAX	MIN	MAX	MIN	MAX		
t_{pd}	Propagation delay	A input to B output	–40°C to 85°C	0.5	47	0.5	50	0.5	62	0.5	151	ns
			–40°C to 125°C	0.5	47	0.5	50	0.5	62	0.5	151	
	B input to A output	–40°C to 85°C	0.5	89	0.5	88	0.5	87	0.5	86		
		–40°C to 125°C	0.5	89	0.5	88	0.5	87	0.5	86		
t_{dis}	Disable time	\overline{OE} input to A output	–40°C to 85°C	0.5	194	0.5	194	0.5	194	0.5	194	ns
			–40°C to 125°C	0.5	194	0.5	194	0.5	194	0.5	194	
	\overline{OE} input to B output	–40°C to 85°C	0.5	70	0.5	69	0.5	67	0.5	101		
		–40°C to 125°C	0.5	70	0.5	69	0.5	67	0.5	101		
t_{en}	Enable time	\overline{OE} input to A output	–40°C to 85°C	0.5	240	0.5	240	0.5	240	0.5	240	ns
			–40°C to 125°C	0.5	240	0.5	240	0.5	240	0.5	240	
	\overline{OE} input to B output	–40°C to 85°C	0.5	69	0.5	69	0.5	84	0.5	552		
		–40°C to 125°C	0.5	69	0.5	69	0.5	84	0.5	552		

6.7 Switching Characteristics, $V_{CCA} = 0.8\text{ V}$

See [Figure 1](#) and [Figure 2](#) for test circuit and loading conditions. See [Figure 3](#) and [Figure 4](#) for measurement waveforms.

PARAMETER		TEST CONDITION	B-PORT SUPPLY VOLTAGE (V_{CCB})								UNIT		
			0.7 V \pm 0.05 V		0.8 V \pm 0.04 V		0.9 V \pm 0.045 V		1.2 V \pm 0.1 V				
			MIN	MAX	MIN	MAX	MIN	MAX	MIN	MAX			
t_{pd}	Propagation delay	A input to B output	–40°C to 85°C		0.5	159	0.5	96	0.5	64	0.5	33	ns
			–40°C to 125°C		0.5	159	0.5	96	0.5	64	0.5	33	
	B input to A output	–40°C to 85°C		0.5	117	0.5	97	0.5	79	0.5	54		
		–40°C to 125°C		0.5	117	0.5	97	0.5	79	0.5	54		
t_{dis}	Disable time	\overline{OE} input to A output	–40°C to 85°C		0.5	154	0.5	154	0.5	154	0.5	154	ns
			–40°C to 125°C		0.5	154	0.5	154	0.5	154	0.5	154	
	\overline{OE} input to B output	–40°C to 85°C		0.5	202	0.5	165	0.5	144	0.5	65		
		–40°C to 125°C		0.5	202	0.5	165	0.5	144	0.5	65		
t_{en}	Enable time	\overline{OE} input to A output	–40°C to 85°C		0.5	137	0.5	137	0.5	137	0.5	137	ns
			–40°C to 125°C		0.5	137	0.5	137	0.5	137	0.5	137	
	\overline{OE} input to B output	–40°C to 85°C		0.5	270	0.5	160	0.5	104	0.5	55		
		–40°C to 125°C		0.5	270	0.5	160	0.5	104	0.5	55		

PARAMETER		TEST CONDITION	B-PORT SUPPLY VOLTAGE (V_{CCB})								UNIT		
			1.5 V \pm 0.1 V		1.8 V \pm 0.15 V		2.5 V \pm 0.2 V		3.3 V \pm 0.3 V				
			MIN	MAX	MIN	MAX	MIN	MAX	MIN	MAX			
t_{pd}	Propagation delay	A input to B output	–40°C to 85°C		0.5	27	0.5	26	0.5	26	0.5	35	ns
			–40°C to 125°C		0.5	27	0.5	26	0.5	26	0.5	35	
	B input to A output	–40°C to 85°C		0.5	44	0.5	43	0.5	42	0.5	41		
		–40°C to 125°C		0.5	44	0.5	43	0.5	42	0.5	41		
t_{dis}	Disable time	\overline{OE} input to A output	–40°C to 85°C		0.5	154	0.5	154	0.5	154	0.5	154	ns
			–40°C to 125°C		0.5	154	0.5	154	0.5	154	0.5	154	
	\overline{OE} input to B output	–40°C to 85°C		0.5	57	0.5	55	0.5	50	0.5	52		
		–40°C to 125°C		0.5	57	0.5	55	0.5	50	0.5	52		
t_{en}	Enable time	\overline{OE} input to A output	–40°C to 85°C		0.5	137	0.5	137	0.5	137	0.5	137	ns
			–40°C to 125°C		0.5	137	0.5	137	0.5	137	0.5	137	
	\overline{OE} input to B output	–40°C to 85°C		0.5	46	0.5	44	0.5	46	0.5	59		
		–40°C to 125°C		0.5	46	0.5	44	0.5	46	0.5	59		

6.8 Switching Characteristics, $V_{CCA} = 0.9\text{ V}$

See Figure 1 and Figure 2 for test circuit and loading conditions. See Figure 3 and Figure 4 for measurement waveforms.

PARAMETER		TEST CONDITION	B-PORT SUPPLY VOLTAGE (V_{CCB})								UNIT		
			0.7 V ± 0.05 V		0.8 V ± 0.04 V		0.9 V ± 0.045 V		1.2 V ± 0.1 V				
			MIN	MAX	MIN	MAX	MIN	MAX	MIN	MAX			
t_{pd}	Propagation delay	A input to output	–40°C to 85°C		0.5	133	0.5	79	0.5	53	0.5	23	ns
			–40°C to 125°C		0.5	133	0.5	79	0.5	53	0.5	23	
	B input to A output	–40°C to 85°C		0.5	84	0.5	64	0.5	53	0.5	41		
		–40°C to 125°C		0.5	84	0.5	64	0.5	53	0.5	41		
t_{dis}	Disable time	\overline{OE} input to A output	–40°C to 85°C		0.5	130	0.5	130	0.5	130	0.5	130	ns
			–40°C to 125°C		0.5	130	0.5	130	0.5	130	0.5	130	
	\overline{OE} input to B output	–40°C to 85°C		0.5	193	0.5	157	0.5	137	0.5	57		
		–40°C to 125°C		0.5	193	0.5	157	0.5	137	0.5	57		
t_{en}	Enable time	\overline{OE} input to A output	–40°C to 85°C		0.5	128	0.5	128	0.5	128	0.5	128	ns
			–40°C to 125°C		0.5	128	0.5	128	0.5	128	0.5	128	
	\overline{OE} input to B output	–40°C to 85°C		0.5	257	0.5	149	0.5	94	0.5	45		
		–40°C to 125°C		0.5	257	0.5	149	0.5	94	0.5	45		

PARAMETER		TEST CONDITION	B-PORT SUPPLY VOLTAGE (V_{CCB})								UNIT		
			1.5 V ± 0.1 V		1.8 V ± 0.15 V		2.5 V ± 0.2 V		3.3 V ± 0.3 V				
			MIN	MAX	MIN	MAX	MIN	MAX	MIN	MAX			
t_{pd}	Propagation delay	A input to B output	–40°C to 85°C		0.5	18	0.5	16	0.5	15	0.5	18	ns
			–40°C to 125°C		0.5	18	0.5	16	0.5	15	0.5	18	
	B input to A output	–40°C to 85°C		0.5	29	0.5	25	0.5	23	0.5	22		
		–40°C to 125°C		0.5	29	0.5	25	0.5	23	0.5	22		
t_{dis}	Disable time	\overline{OE} input to A output	–40°C to 85°C		0.5	130	0.5	130	0.5	130	0.5	130	ns
			–40°C to 125°C		0.5	130	0.5	130	0.5	130	0.5	130	
	\overline{OE} input to B output	–40°C to 85°C		0.5	50	0.5	48	0.5	42	0.5	43		
		–40°C to 125°C		0.5	50	0.5	48	0.5	42	0.5	43		
t_{en}	Enable time	\overline{OE} input to A output	–40°C to 85°C		0.5	128	0.5	128	0.5	128	0.5	128	ns
			–40°C to 125°C		0.5	128	0.5	128	0.5	128	0.5	128	
	\overline{OE} input to B output	–40°C to 85°C		0.5	37	0.5	34	0.5	32	0.5	36		
		–40°C to 125°C		0.5	37	0.5	34	0.5	32	0.5	36		

6.9 Switching Characteristics, $V_{CCA} = 1.2\text{ V}$

See Figure 1 and Figure 2 for test circuit and loading conditions. See Figure 3 and Figure 4 for measurement waveforms.

PARAMETER		TEST CONDITION	B-PORT SUPPLY VOLTAGE (V_{CCB})								UNIT	
			0.7 V ± 0.05 V		0.8 V ± 0.04 V		0.9 V ± 0.045 V		1.2 V ± 0.1 V			
			MIN	MAX	MIN	MAX	MIN	MAX	MIN	MAX		
t_{pd}	Propagation delay	A input to B output	–40°C to 85°C	0.5	95	0.5	54	0.5	40	0.5	15	ns
			–40°C to 125°C	0.5	95	0.5	54	0.5	40	0.5	15	
	B input to A output	–40°C to 85°C	0.5	49	0.5	33	0.5	23	0.5	15		
		–40°C to 125°C	0.5	49	0.5	33	0.5	23	0.5	15		
t_{dis}	Disable time	\overline{OE} input to A output	–40°C to 85°C	0.5	47	0.5	47	0.5	47	0.5	47	ns
			–40°C to 125°C	0.5	47	0.5	47	0.5	47	0.5	47	
	\overline{OE} input to B output	–40°C to 85°C	0.5	181	0.5	147	0.5	127	0.5	49		
		–40°C to 125°C	0.5	181	0.5	147	0.5	127	0.5	49		
t_{en}	Enable time	\overline{OE} input to A output	–40°C to 85°C	0.5	40	0.5	40	0.5	40	0.5	40	ns
			–40°C to 125°C	0.5	40	0.5	40	0.5	40	0.5	40	
	\overline{OE} input to B output	–40°C to 85°C	0.5	221	0.5	132	0.5	81	0.5	34		
		–40°C to 125°C	0.5	221	0.5	132	0.5	81	0.5	34		

PARAMETER		TEST CONDITION	B-PORT SUPPLY VOLTAGE (V_{CCB})								UNIT	
			1.5 V ± 0.1 V		1.8 V ± 0.15 V		2.5 V ± 0.2 V		3.3 V ± 0.3 V			
			MIN	MAX	MIN	MAX	MIN	MAX	MIN	MAX		
t_{pd}	Propagation delay	A input to B output	–40°C to 85°C	0.5	11	0.5	9	0.5	8	0.5	8	ns
			–40°C to 125°C	0.5	11	0.5	9	0.5	8	0.5	8	
	B input to A output	–40°C to 85°C	0.5	12	0.5	10	0.5	8	0.5	8		
		–40°C to 125°C	0.5	12	0.5	10	0.5	8	0.5	8		
t_{dis}	Disable time	\overline{OE} input to A output	–40°C to 85°C	0.5	47	0.5	47	0.5	47	0.5	47	ns
			–40°C to 125°C	0.5	47	0.5	47	0.5	47	0.5	47	
	\overline{OE} input to B output	–40°C to 85°C	0.5	42	0.5	40	0.5	34	0.5	34		
		–40°C to 125°C	0.5	42	0.5	40	0.5	34	0.5	34		
t_{en}	Enable time	\overline{OE} input to A output	–40°C to 85°C	0.5	39	0.5	40	0.5	40	0.5	40	ns
			–40°C to 125°C	0.5	39	0.5	40	0.5	40	0.5	40	
	\overline{OE} input to B output	–40°C to 85°C	0.5	25	0.5	22	0.5	20	0.5	19		
		–40°C to 125°C	0.5	25	0.5	22	0.5	20	0.5	19		

6.10 Switching Characteristics, $V_{CCA} = 1.5\text{ V}$

See Figure 1 and Figure 2 for test circuit and loading conditions. See Figure 3 and Figure 4 for measurement waveforms.

PARAMETER		TEST CONDITION	B-PORT SUPPLY VOLTAGE (V_{CCB})								UNIT		
			0.7 V \pm 0.05 V		0.8 V \pm 0.04 V		0.9 V \pm 0.045 V		1.2 V \pm 0.1 V				
			MIN	MAX	MIN	MAX	MIN	MAX	MIN	MAX			
t_{pd}	Propagation delay	A input to B output	–40°C to 85°C		0.5	90	0.5	44	0.5	29	0.5	12	ns
			–40°C to 125°C		0.5	90	0.5	44	0.5	29	0.5	12	
	B input to A output	–40°C to 85°C		0.5	47	0.5	27	0.5	18	0.5	11		
		–40°C to 125°C		0.5	47	0.5	27	0.5	18	0.5	11		
t_{dis}	Disable time	\overline{OE} input to A output	–40°C to 85°C		0.5	37	0.5	37	0.5	37	0.5	37	ns
			–40°C to 125°C		0.5	37	0.5	37	0.5	37	0.5	37	
	\overline{OE} input to B output	–40°C to 85°C		0.5	176	0.5	142	0.5	122	0.5	44		
		–40°C to 125°C		0.5	176	0.5	142	0.5	122	0.5	44		
t_{en}	Enable time	\overline{OE} input to A output	–40°C to 85°C		0.5	25	0.5	25	0.5	25	0.5	25	ns
			–40°C to 125°C		0.5	25	0.5	25	0.5	25	0.5	25	
	\overline{OE} input to B output	–40°C to 85°C		0.5	214	0.5	114	0.5	71	0.5	29		
		–40°C to 125°C		0.5	214	0.5	114	0.5	71	0.5	29		

PARAMETER		TEST CONDITION	B-PORT SUPPLY VOLTAGE (V_{CCB})								UNIT		
			1.5 V \pm 0.1 V		1.8 V \pm 0.15 V		2.5 V \pm 0.2 V		3.3 V \pm 0.3 V				
			MIN	MAX	MIN	MAX	MIN	MAX	MIN	MAX			
t_{pd}	Propagation delay	A input to B output	–40°C to 85°C		0.5	9	0.5	8	0.5	6	0.5	6	ns
			–40°C to 125°C		0.5	9	0.5	8	0.5	6	0.5	6	
	B input to A output	–40°C to 85°C		0.5	9	0.5	8	0.5	6	0.5	5		
		–40°C to 125°C		0.5	9	0.5	8	0.5	6	0.5	5		
t_{dis}	Disable time	\overline{OE} input to A output	–40°C to 85°C		0.5	37	0.5	37	0.5	37	0.5	37	ns
			–40°C to 125°C		0.5	37	0.5	37	0.5	37	0.5	37	
	\overline{OE} input to B output	–40°C to 85°C		0.5	38	0.5	37	0.5	31	0.5	31		
		–40°C to 125°C		0.5	38	0.5	37	0.5	31	0.5	31		
t_{en}	Enable time	\overline{OE} input to A output	–40°C to 85°C		0.5	25	0.5	25	0.5	25	0.5	25	ns
			–40°C to 125°C		0.5	25	0.5	25	0.5	25	0.5	25	
	\overline{OE} input to B output	–40°C to 85°C		0.5	21	0.5	18	0.5	15	0.5	13		
		–40°C to 125°C		0.5	21	0.5	18	0.5	15	0.5	13		

6.11 Switching Characteristics, $V_{CCA} = 1.8\text{ V}$

See Figure 1 and Figure 2 for test circuit and loading conditions. See Figure 3 and Figure 4 for measurement waveforms.

PARAMETER		TEST CONDITION	B-PORT SUPPLY VOLTAGE (V_{CCB})								UNIT	
			0.7 V \pm 0.05 V		0.8 V \pm 0.04 V		0.9 V \pm 0.045 V		1.2 V \pm 0.1 V			
			MIN	MAX	MIN	MAX	MIN	MAX	MIN	MAX		
t_{pd}	Propagation delay	A input to B output	-40°C to 85°C	0.5	88	0.5	43	0.5	25	0.5	10	ns
			-40°C to 125°C	0.5	88	0.5	43	0.5	25	0.5	10	
	B input to A output	-40°C to 85°C	0.5	50	0.5	26	0.5	16	0.5	9		
		-40°C to 125°C	0.5	50	0.5	26	0.5	16	0.5	9		
t_{dis}	Disable time	\overline{OE} input to A output	-40°C to 85°C	0.5	35	0.5	35	0.5	35	0.5	35	ns
			-40°C to 125°C	0.5	35	0.5	35	0.5	35	0.5	35	
	\overline{OE} input to B output	-40°C to 85°C	0.5	174	0.5	139	0.5	119	0.5	42		
		-40°C to 125°C	0.5	174	0.5	139	0.5	119	0.5	42		
t_{en}	Enable time	\overline{OE} input to A output	-40°C to 85°C	0.5	20	0.5	20	0.5	20	0.5	20	ns
			-40°C to 125°C	0.5	20	0.5	20	0.5	20	0.5	20	
	\overline{OE} input to B output	-40°C to 85°C	0.5	213	0.5	111	0.5	67	0.5	27		
		-40°C to 125°C	0.5	213	0.5	111	0.5	67	0.5	27		

PARAMETER		TEST CONDITION	B-PORT SUPPLY VOLTAGE (V_{CCB})								UNIT	
			1.5 V \pm 0.1 V		1.8 V \pm 0.15 V		2.5 V \pm 0.2 V		3.3 V \pm 0.3 V			
			MIN	MAX	MIN	MAX	MIN	MAX	MIN	MAX		
t_{pd}	Propagation delay	A input to B output	-40°C to 85°C	0.5	8	0.5	7	0.5	6	0.5	5	ns
			-40°C to 125°C	0.5	8	0.5	7	0.5	6	0.5	5	
	B input to A output	-40°C to 85°C	0.5	7	0.5	6	0.5	5	0.5	4		
		-40°C to 125°C	0.5	7	0.5	7	0.5	5	0.5	4		
t_{dis}	Disable time	\overline{OE} input to A output	-40°C to 85°C	0.5	35	0.5	35	0.5	35	0.5	35	ns
			-40°C to 125°C	0.5	35	0.5	35	0.5	35	0.5	35	
	\overline{OE} input to B output	-40°C to 85°C	0.5	36	0.5	35	0.5	30	0.5	29		
		-40°C to 125°C	0.5	36	0.5	35	0.5	30	0.5	29		
t_{en}	Enable time	\overline{OE} input to A output	-40°C to 85°C	0.5	20	0.5	20	0.5	20	0.5	20	ns
			-40°C to 125°C	0.5	20	0.5	20	0.5	20	0.5	20	
	\overline{OE} input to B output	-40°C to 85°C	0.5	19	0.5	16	0.5	13	0.5	11		
		-40°C to 125°C	0.5	19	0.5	16	0.5	13	0.5	11		

6.12 Switching Characteristics, $V_{CCA} = 2.5\text{ V}$

See Figure 1 and Figure 2 for test circuit and loading conditions. See Figure 3 and Figure 4 for measurement waveforms.

PARAMETER		TEST CONDITION	B-PORT SUPPLY VOLTAGE (V_{CCB})								UNIT	
			0.7 V ± 0.05 V		0.8 V ± 0.04 V		0.9 V ± 0.045 V		1.2 V ± 0.1 V			
			MIN	MAX	MIN	MAX	MIN	MAX	MIN	MAX		
t_{pd}	Propagation delay	A input to B output	–40°C to 85°C	0.5	87	0.5	42	0.5	23	0.5	8	ns
			–40°C to 125°C	0.5	87	0.5	42	0.5	23	0.5	8	
	B input to A output	–40°C to 85°C	0.5	62	0.5	26	0.5	15	0.5	8		
		–40°C to 125°C	0.5	62	0.5	26	0.5	15	0.5	8		
t_{dis}	Disable time	\overline{OE} input to A output	–40°C to 85°C	0.5	28	0.5	28	0.5	28	0.5	28	ns
			–40°C to 125°C	0.5	28	0.5	28	0.5	28	0.5	28	
	\overline{OE} input to B output	–40°C to 85°C	0.5	173	0.5	137	0.5	117	0.5	40		
		–40°C to 125°C	0.5	173	0.5	137	0.5	117	0.5	40		
t_{en}	Enable time	\overline{OE} input to A output	–40°C to 85°C	0.5	13	0.5	13	0.5	13	0.5	13	ns
			–40°C to 125°C	0.5	13	0.5	13	0.5	13	0.5	13	
	\overline{OE} input to B output	–40°C to 85°C	0.5	211	0.5	107	0.5	63	0.5	24		
		–40°C to 125°C	0.5	211	0.5	107	0.5	63	0.5	24		

PARAMETER		TEST CONDITION	B-PORT SUPPLY VOLTAGE (V_{CCB})								UNIT	
			1.5 V ± 0.1 V		1.8 V ± 0.15 V		2.5 V ± 0.2 V		3.3 V ± 0.3 V			
			MIN	MAX	MIN	MAX	MIN	MAX	MIN	MAX		
t_{pd}	Propagation delay	A input to B output	–40°C to 85°C	0.5	6	0.5	6	0.5	5	0.5	5	ns
			–40°C to 125°C	0.5	6	0.5	6	0.5	5	0.5	5	
	B input to A output	–40°C to 85°C	0.5	6	0.5	6	0.5	5	0.5	4		
		–40°C to 125°C	0.5	6	0.5	6	0.5	5	0.5	4		
t_{dis}	Disable time	\overline{OE} input to A output	–40°C to 85°C	0.5	28	0.5	28	0.5	28	0.5	28	ns
			–40°C to 125°C	0.5	28	0.5	28	0.5	28	0.5	28	
	\overline{OE} input to B output	–40°C to 85°C	0.5	34	0.5	33	0.5	28	0.5	28		
		–40°C to 125°C	0.5	34	0.5	33	0.5	28	0.5	28		
t_{en}	Enable time	\overline{OE} input to A output	–40°C to 85°C	0.5	13	0.5	13	0.5	13	0.5	13	ns
			–40°C to 125°C	0.5	13	0.5	13	0.5	13	0.5	13	
	\overline{OE} input to B output	–40°C to 85°C	0.5	16	0.5	14	0.5	10	0.5	9		
		–40°C to 125°C	0.5	16	0.5	14	0.5	10	0.5	9		

6.13 Switching Characteristics, $V_{CCA} = 3.3\text{ V}$

See Figure 1 and Figure 2 for test circuit and loading conditions. See Figure 3 and Figure 4 for measurement waveforms.

PARAMETER		TEST CONDITION	B-PORT SUPPLY VOLTAGE (V_{CCB})								UNIT
			0.7 V \pm 0.05 V		0.8 V \pm 0.04 V		0.9 V \pm 0.045 V		1.2 V \pm 0.1 V		
			MIN	MAX	MIN	MAX	MIN	MAX	MIN	MAX	
t_{pd} Propagation delay	A input to B output	–40°C to 85°C	0.5	87	0.5	41	0.5	22	0.5	8	ns
		–40°C to 125°C	0.5	87	0.5	41	0.5	22	0.5	8	
	B input to A output	–40°C to 85°C	0.5	151	0.5	36	0.5	18	0.5	8	
		–40°C to 125°C	0.5	151	0.5	36	0.5	18	0.5	8	
t_{dis} Disable time	\overline{OE} input to A output	–40°C to 85°C	0.5	27	0.5	27	0.5	27	0.5	27	ns
		–40°C to 125°C	0.5	27	0.5	27	0.5	27	0.5	27	
	\overline{OE} input to B output	–40°C to 85°C	0.5	172	0.5	136	0.5	116	0.5	39	
		–40°C to 125°C	0.5	172	0.5	136	0.5	116	0.5	39	
t_{en} Enable time	\overline{OE} input to A output	–40°C to 85°C	0.5	11	0.5	11	0.5	11	0.5	11	ns
		–40°C to 125°C	0.5	11	0.5	11	0.5	11	0.5	11	
	\overline{OE} input to B output	–40°C to 85°C	0.5	210	0.5	106	0.5	62	0.5	23	
		–40°C to 125°C	0.5	210	0.5	106	0.5	62	0.5	23	

PARAMETER		TEST CONDITION	B-PORT SUPPLY VOLTAGE (V_{CCB})								UNIT
			1.5 V \pm 0.1 V		1.8 V \pm 0.15 V		2.5 V \pm 0.2 V		3.3 V \pm 0.3 V		
			MIN	MAX	MIN	MAX	MIN	MAX	MIN	MAX	
t_{pd} Propagation delay	A input to B output	–40°C to 85°C	0.5	5	0.5	5	0.5	4	0.5	4	ns
		–40°C to 125°C	0.5	5	0.5	5	0.5	4	0.5	4	
	B input to A output	–40°C to 85°C	0.5	6	0.5	5	0.5	5	0.5	4	
		–40°C to 125°C	0.5	6	0.5	5	0.5	5	0.5	4	
t_{dis} Disable time	\overline{OE} input to A output	–40°C to 85°C	0.5	27	0.5	27	0.5	27	0.5	27	ns
		–40°C to 125°C	0.5	27	0.5	27	0.5	27	0.5	27	
	\overline{OE} input to B output	–40°C to 85°C	0.5	33	0.5	32	0.5	27	0.5	27	
		–40°C to 125°C	0.5	33	0.5	32	0.5	27	0.5	27	
t_{en} Enable time	\overline{OE} input to A output	–40°C to 85°C	0.5	11	0.5	11	0.5	11	0.5	11	ns
		–40°C to 125°C	0.5	11	0.5	11	0.5	11	0.5	11	
	\overline{OE} input to B output	–40°C to 85°C	0.5	15	0.5	13	0.5	10	0.5	8	
		–40°C to 125°C	0.5	15	0.5	13	0.5	10	0.5	8	

6.14 Operating Characteristics: $T_A = 25^\circ\text{C}$

PARAMETER	TEST CONDITIONS	MIN	TYP	MAX	UNIT
C_{pdA} Power dissipation capacitance per transceiver (A to B: outputs enabled)	$C_L = 0$, $R_L = \text{Open}$ $f = 1 \text{ MHz}$, $t_r = t_f = 1 \text{ ns}$	$V_{CCA} = V_{CCB} = 0.7 \text{ V}$		3.0	pF
		$V_{CCA} = V_{CCB} = 0.8 \text{ V}$		3.0	
		$V_{CCA} = V_{CCB} = 0.9 \text{ V}$		3.0	
		$V_{CCA} = V_{CCB} = 1.2 \text{ V}$		3.1	
		$V_{CCA} = V_{CCB} = 1.5 \text{ V}$		3.0	
		$V_{CCA} = V_{CCB} = 1.8 \text{ V}$		3.2	
		$V_{CCA} = V_{CCB} = 2.5 \text{ V}$		3.7	
		$V_{CCA} = V_{CCB} = 3.3 \text{ V}$		4.4	
C_{pdA} Power dissipation capacitance per transceiver (A to B: outputs disabled)	$C_L = 0$, $R_L = \text{Open}$ $f = 1 \text{ MHz}$, $t_r = t_f = 1 \text{ ns}$	$V_{CCA} = V_{CCB} = 0.7 \text{ V}$		2.5	pF
		$V_{CCA} = V_{CCB} = 0.8 \text{ V}$		2.5	
		$V_{CCA} = V_{CCB} = 0.9 \text{ V}$		2.6	
		$V_{CCA} = V_{CCB} = 1.2 \text{ V}$		2.6	
		$V_{CCA} = V_{CCB} = 1.5 \text{ V}$		2.6	
		$V_{CCA} = V_{CCB} = 1.8 \text{ V}$		2.7	
		$V_{CCA} = V_{CCB} = 2.5 \text{ V}$		3.2	
		$V_{CCA} = V_{CCB} = 3.3 \text{ V}$		3.9	
C_{pdA} Power dissipation capacitance per transceiver (B to A: outputs enabled)	$C_L = 0$, $R_L = \text{Open}$ $f = 1 \text{ MHz}$, $t_r = t_f = 1 \text{ ns}$	$V_{CCA} = V_{CCB} = 0.7 \text{ V}$		12.6	pF
		$V_{CCA} = V_{CCB} = 0.8 \text{ V}$		12.3	
		$V_{CCA} = V_{CCB} = 0.9 \text{ V}$		12.4	
		$V_{CCA} = V_{CCB} = 1.2 \text{ V}$		12.4	
		$V_{CCA} = V_{CCB} = 1.5 \text{ V}$		12.7	
		$V_{CCA} = V_{CCB} = 1.8 \text{ V}$		13.6	
		$V_{CCA} = V_{CCB} = 2.5 \text{ V}$		17.4	
		$V_{CCA} = V_{CCB} = 3.3 \text{ V}$		20.9	
C_{pdA} Power dissipation capacitance per transceiver (B to A: outputs disabled)	$C_L = 0$, $R_L = \text{Open}$ $f = 1 \text{ MHz}$, $t_r = t_f = 1 \text{ ns}$	$V_{CCA} = V_{CCB} = 0.7 \text{ V}$		1.2	pF
		$V_{CCA} = V_{CCB} = 0.8 \text{ V}$		1.1	
		$V_{CCA} = V_{CCB} = 0.9 \text{ V}$		1.1	
		$V_{CCA} = V_{CCB} = 1.2 \text{ V}$		1.0	
		$V_{CCA} = V_{CCB} = 1.5 \text{ V}$		1.0	
		$V_{CCA} = V_{CCB} = 1.8 \text{ V}$		0.9	
		$V_{CCA} = V_{CCB} = 2.5 \text{ V}$		0.9	
		$V_{CCA} = V_{CCB} = 3.3 \text{ V}$		0.9	

Operating Characteristics: $T_A = 25^\circ\text{C}$ (continued)

PARAMETER	TEST CONDITIONS	MIN	TYP	MAX	UNIT
C_{pdB} Power dissipation capacitance per transceiver (A to B: outputs enabled)	$C_L = 0$, $R_L = \text{Open}$ $f = 1 \text{ MHz}$, $t_r = t_f = 1 \text{ ns}$	$V_{CCA} = V_{CCB} = 0.7 \text{ V}$	12.6		pF
		$V_{CCA} = V_{CCB} = 0.8 \text{ V}$	12.4		
		$V_{CCA} = V_{CCB} = 0.9 \text{ V}$	12.4		
		$V_{CCA} = V_{CCB} = 1.2 \text{ V}$	12.4		
		$V_{CCA} = V_{CCB} = 1.5 \text{ V}$	12.6		
		$V_{CCA} = V_{CCB} = 1.8 \text{ V}$	13.6		
		$V_{CCA} = V_{CCB} = 2.5 \text{ V}$	17.2		
		$V_{CCA} = V_{CCB} = 3.3 \text{ V}$	20.8		
C_{pdB} Power dissipation capacitance per transceiver (A to B: outputs disabled)	$C_L = 0$, $R_L = \text{Open}$ $f = 1 \text{ MHz}$, $t_r = t_f = 1 \text{ ns}$	$V_{CCA} = V_{CCB} = 0.7 \text{ V}$	1.4		pF
		$V_{CCA} = V_{CCB} = 0.8 \text{ V}$	1.3		
		$V_{CCA} = V_{CCB} = 0.9 \text{ V}$	1.3		
		$V_{CCA} = V_{CCB} = 1.2 \text{ V}$	1.2		
		$V_{CCA} = V_{CCB} = 1.5 \text{ V}$	1.1		
		$V_{CCA} = V_{CCB} = 1.8 \text{ V}$	1.1		
		$V_{CCA} = V_{CCB} = 2.5 \text{ V}$	1.1		
		$V_{CCA} = V_{CCB} = 3.3 \text{ V}$	1.0		
C_{pdB} Power dissipation capacitance per transceiver (B to A: outputs enabled)	$C_L = 0$, $R_L = \text{Open}$ $f = 1 \text{ MHz}$, $t_r = t_f = 1 \text{ ns}$	$V_{CCA} = V_{CCB} = 0.7 \text{ V}$	3.3		pF
		$V_{CCA} = V_{CCB} = 0.8 \text{ V}$	3.3		
		$V_{CCA} = V_{CCB} = 0.9 \text{ V}$	3.3		
		$V_{CCA} = V_{CCB} = 1.2 \text{ V}$	3.2		
		$V_{CCA} = V_{CCB} = 1.5 \text{ V}$	3.2		
		$V_{CCA} = V_{CCB} = 1.8 \text{ V}$	3.3		
		$V_{CCA} = V_{CCB} = 2.5 \text{ V}$	3.6		
		$V_{CCA} = V_{CCB} = 3.3 \text{ V}$	4.4		
C_{pdB} Power dissipation capacitance per transceiver (B to A: outputs disabled)	$C_L = 0$, $R_L = \text{Open}$ $f = 1 \text{ MHz}$, $t_r = t_f = 1 \text{ ns}$	$V_{CCA} = V_{CCB} = 0.7 \text{ V}$	2.8		pF
		$V_{CCA} = V_{CCB} = 0.8 \text{ V}$	2.8		
		$V_{CCA} = V_{CCB} = 0.9 \text{ V}$	2.8		
		$V_{CCA} = V_{CCB} = 1.2 \text{ V}$	2.8		
		$V_{CCA} = V_{CCB} = 1.5 \text{ V}$	2.7		
		$V_{CCA} = V_{CCB} = 1.8 \text{ V}$	2.8		
		$V_{CCA} = V_{CCB} = 2.5 \text{ V}$	3.1		
		$V_{CCA} = V_{CCB} = 3.3 \text{ V}$	3.9		

7 Parameter Measurement Information

Unless otherwise noted, all input pulses are supplied by generators having the following characteristics:

- $f = 1$ MHz
- $Z_0 = 50 \Omega$
- $dv / dt \leq 1$ ns/V

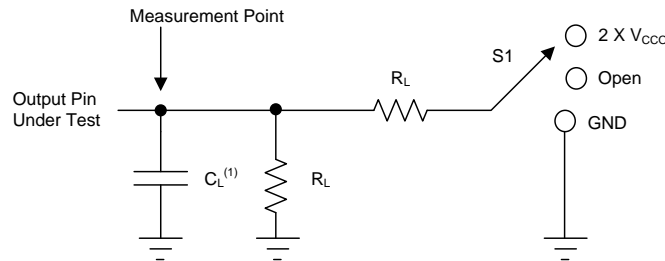

(1) C_L includes probe and jig capacitance.

图 1. Load Circuit

Parameter	V_{CC0}	R_L	C_L	S1	V_{TP}
t_{pd}	1.1 V - 3.6 V	2 k Ω	15 pF	Open	N/A
	0.65 V - 0.95 V	20 k Ω	15 pF	Open	N/A
$t_{en}^{(1)}, t_{dis}^{(1)}$	3 V - 3.6 V	2 k Ω	15 pF	2 X V_{CC0}	0.3 V
	1.65 V - 2.7 V	2 k Ω	15 pF	2 X V_{CC0}	0.15 V
	1.1 V - 1.6 V	2 k Ω	15 pF	2 X V_{CC0}	0.1 V
	0.65 V - 0.95 V	20 k Ω	15 pF	2 X V_{CC0}	0.1 V
$t_{en}^{(2)}, t_{dis}^{(2)}$	3 V - 3.6 V	2 k Ω	15 pF	GND	0.3 V
	1.65 V - 2.7 V	2 k Ω	15 pF	GND	0.15 V
	1.1 V - 1.6 V	2 k Ω	15 pF	GND	0.1 V
	0.65 V - 0.95 V	20 k Ω	15 pF	GND	0.1 V

- (1) Output waveform on the conditions that input is driven to a valid Logic Low.
- (2) Output waveform on the condition that input is driven to a valid Logic High.

图 2. Load Circuit Conditions

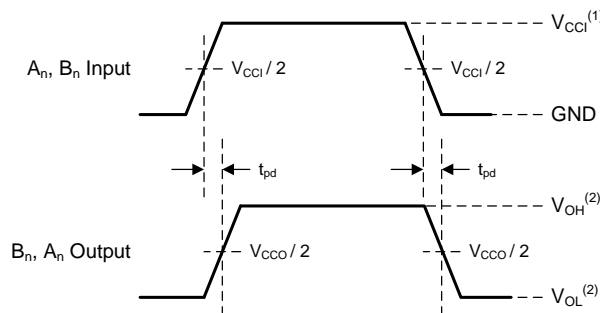

- (1) V_{CCI} is the supply pin associated with the input port.
- (2) V_{OH} and V_{OL} are typical output voltage levels with specified R_L , C_L , and S_1 .

图 3. Propagation Delay

Parameter Measurement Information (接下页)

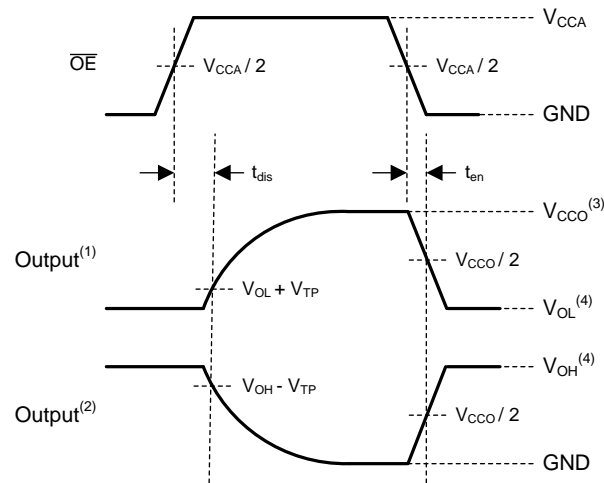

- (1) Output waveform on the condition that input is driven to a valid Logic Low.
- (2) Output waveform on the condition that input is driven to a valid Logic High.
- (3) V_{CCO} is the supply pin associated with the output port.
- (4) V_{OH} and V_{OL} are typical output voltage levels with specified R_L, C_L, and S₁.

图 4. Enable Time And Disable Time

8 Detailed Description

8.1 Overview

The SN74AXCH8T245 device is an 8-bit, dual-supply non-inverting transceiver with bidirectional voltage level translation. The I/O pins labeled with A and the control pins (DIR1, DIR2, and \overline{OE}) are supported by V_{CCA} , and the I/O pins labeled with B are supported by V_{CCB} . Both the A port and the B port are able to accept I/O voltages ranging from 0.65 V to 3.6 V.

8.2 Functional Block Diagram



图 5. Functional Block Diagram

8.3 Feature Description

8.3.1 Up-Translation and Down-Translation From 0.65 V to 3.6 V

Both supply pins are configurable over the full 0.65 V to 3.6 V voltage range, which makes the device suitable for translating between any of the low voltage nodes (0.7 V, 0.8 V, 0.9 V, 1.2 V, 1.8 V, 2.5 V, and 3.3 V).

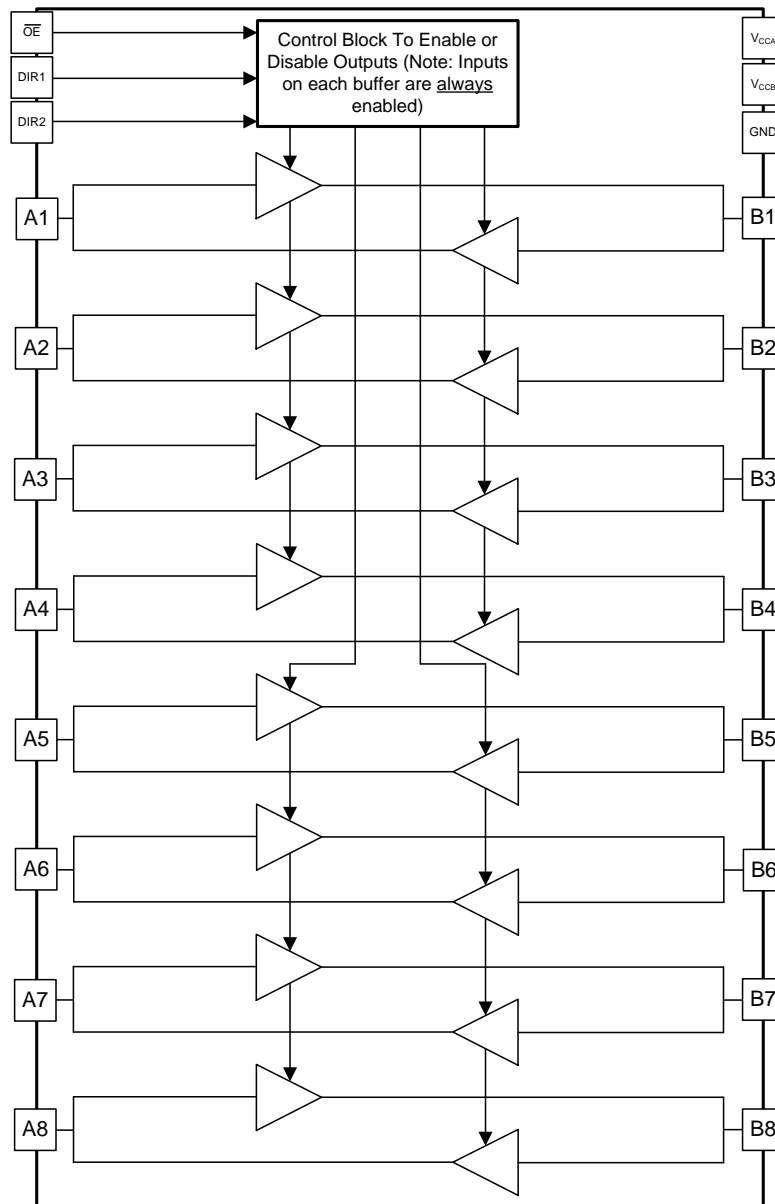
8.3.2 Multiple Direction Control Pins

Two control pins are used to configure the 8 data I/Os. I/O channels 1 through 4 are grouped together and I/O channels 5 through 8 are banked together. The benefit of this is to permit simultaneous up-translation and down-translation within one device. This eliminates the need for multiple devices, where each device can only provide up-translation or down-translation sequentially. Simultaneous up and down translation is supported when both V_{CCA} and V_{CCB} are at least 1.40 V.

8.3.3 Bus-Hold Circuitry

Active bus-hold circuitry holds unused or undriven data inputs at a valid logic state, which helps with board space savings and reduced component costs. Use of pull-up or pull-down resistors with the bus-hold circuitry is not recommended. See the Bus-Hold Circuit application note for more details. (SCLA015).

Note that the bus-hold circuitry always remains active when the corresponding supply is present (i.e. B port bus-hold circuits are active when V_{CCB} is present, and A port bus-hold circuits are active when V_{CCA} is present). The bus hold circuitry is also active even when the device is in a partial power down state or when the output enable pin is used to place all outputs into high impedance.

8.3.4 I_{off} Supports Partial-Power-Down Mode Operation

This feature is to limit the leakage current of an I/O pin being driven to a voltage as large as 3.6 V while having its corresponding power supply rail powered down. This is represented by the I_{off} parameter in the [Electrical Characteristics](#) table.

8.4 Device Functional Modes

All control inputs are referenced to V_{CCA} and must be driven to a valid Logic High or Logic Low (that is, not floating) to assure proper device operation and to prevent excessive power consumption. 表 1 summarizes the possible modes of device operation based on the configuration of the control inputs.

表 1. Function Table⁽¹⁾

CONTROL INPUTS			Signal Direction	
\overline{OE}	DIR1	DIR2	Bits 1:4	Bits 5:8
H	X	X	Disabled (Hi-Z)	
L	L	L	B to A	
L	L	H	B to A	A to B
L	H	L	A to B	
L	H	H	A to B	B to A

(1) Input circuits of the data I/Os are always active and must be driven to a valid logic level.

9 Application and Implementation

注

Information in the following applications sections is not part of the TI component specification, and TI does not warrant its accuracy or completeness. TI's customers are responsible for determining suitability of components for their purposes. Customers should validate and test their design implementation to confirm system functionality.

9.1 Application Information

The SN74AXCH8T245 device can be used in level-translation applications for interfacing devices or systems operating at different voltage nodes. [图 6](#) depicts an application in which the SN74AXCH8T245 device is up-translating a 0.7 V input to a 3.3 V output to interface between a system controller and a peripheral device.

9.2 Typical Application



图 6. Typical Application Schematic

Typical Application (接下页)

9.2.1 Design Requirements

For this design example, use the parameters listed in 表 2.

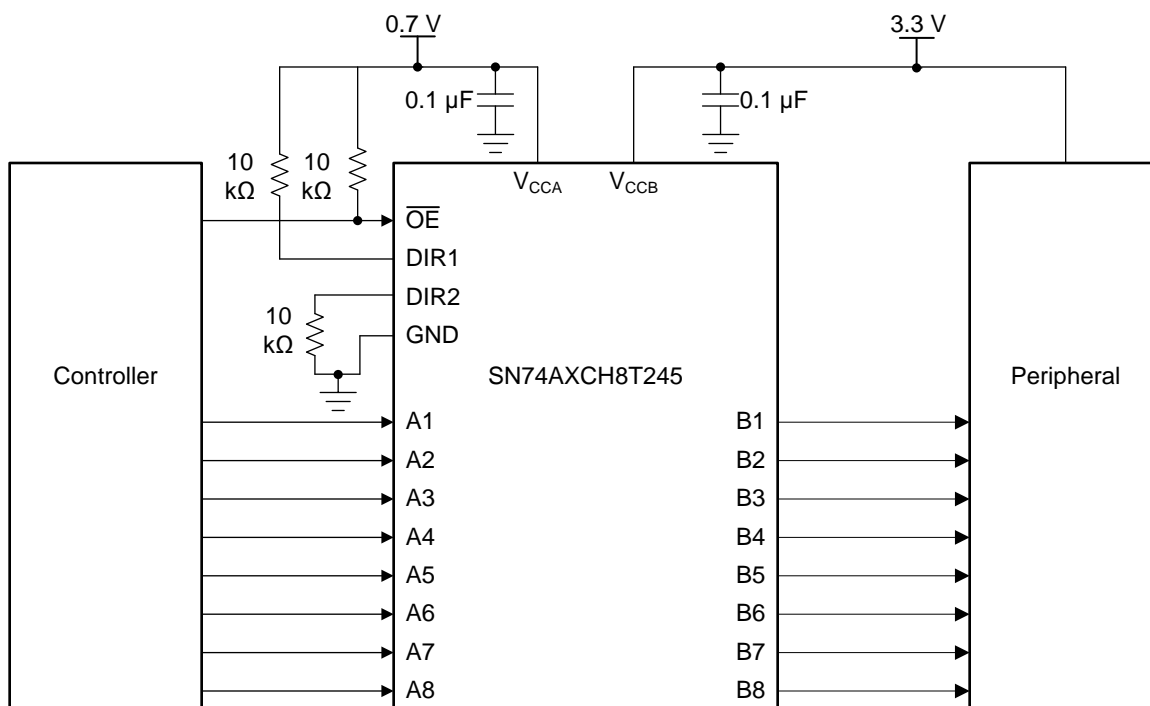
表 2. Design Parameters

DESIGN PARAMETERS	EXAMPLE VALUE
Input voltage range	0.65 V to 3.6 V
Output voltage range	0.65 V to 3.6 V

9.2.2 Detailed Design Procedure

To begin the design process, determine the following:

- Input voltage range
 - Use the supply voltage of the device that is driving the SN74AXCH8T245 device to determine the input voltage range. For a valid logic high the value must exceed the V_{IH} of the input port. For a valid logic low the value must be less than the V_{IL} of the input port.
- Output voltage range
 - Use the supply voltage of the device that the SN74AXCH8T245 device is driving to determine the output voltage range.

9.2.3 Application Curve



图 7. Translation Up (0.7 V to 3.3 V) at 2.5 MHz

10 Power Supply Recommendations

Always apply a ground reference to the GND pins first. However, there are no additional requirements for power supply sequencing.

This device was designed with various power supply sequencing methods in mind to help prevent unintended triggering of downstream devices. For more information regarding the power up glitch performance of the AXC family of level translators, see the [Power Sequencing for AXC Family of Devices](#) application report.

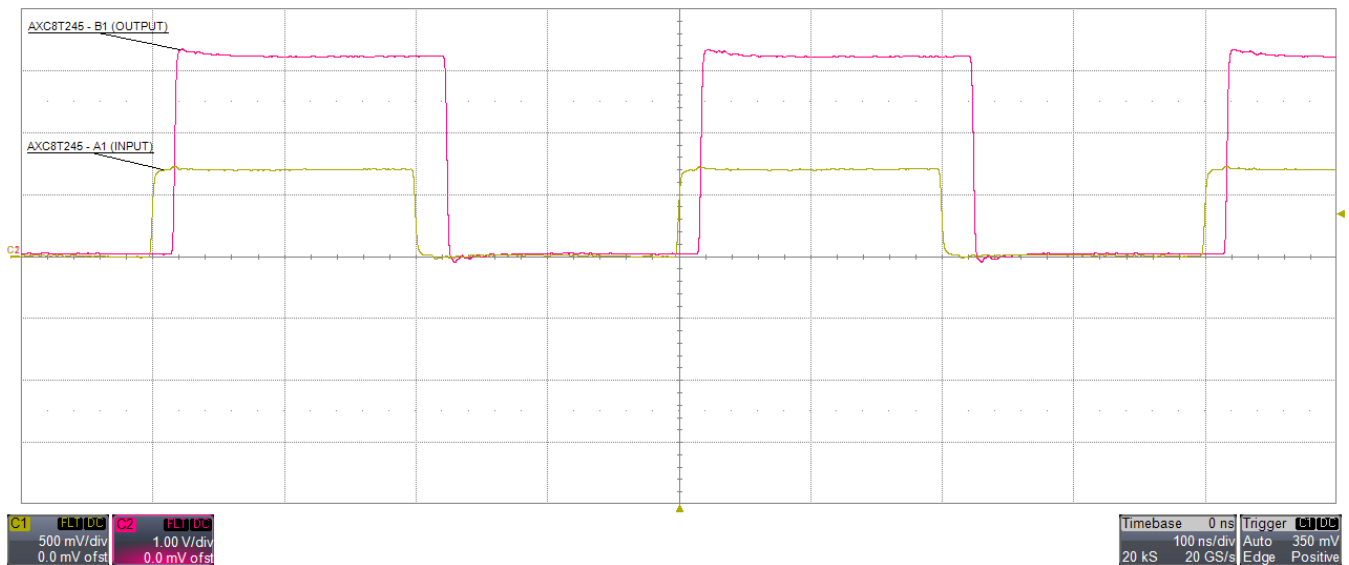
11 Layout

11.1 Layout Guidelines

To assure reliability of the device, follow common printed-circuit board layout guidelines.

- Use bypass capacitors on power supplies.
- Use short trace lengths to avoid excessive loading.
- Place pads on the signal paths for loading capacitors or pullup resistors to help adjust rise and fall times of signals depending on the system requirements.

11.2 Layout Example



图 8. SN74AXCH8T245 Device Layout Example

12 器件和文档支持

12.1 文档支持

12.1.1 相关文档

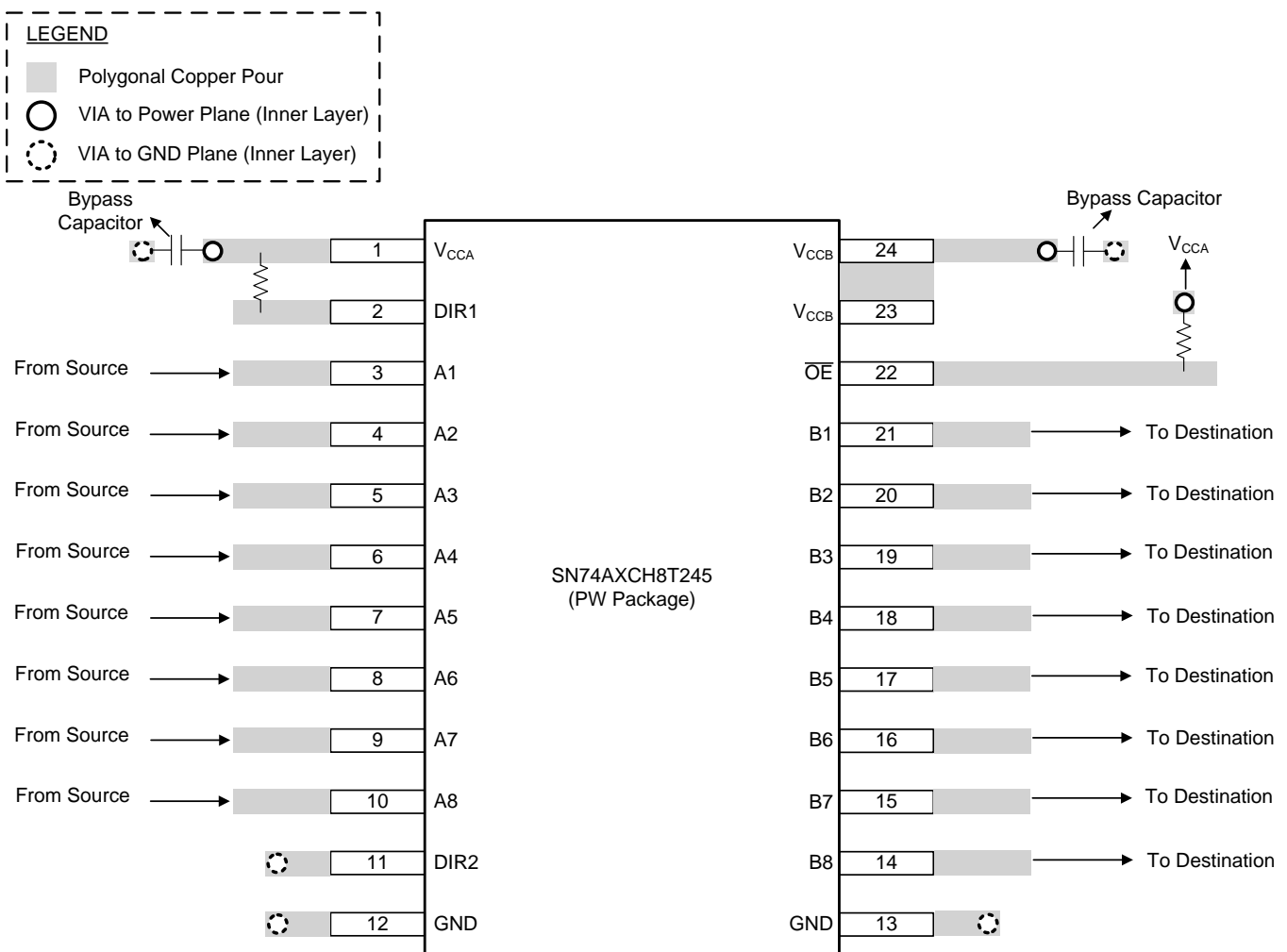
请参阅如下相关文档:

德州仪器 (TI), 《慢速或浮点 CMOS 输入的影响》应用报告

德州仪器 (TI), 《AXC 系列器件电源定序》应用报告

12.2 接收文档更新通知

要接收文档更新通知, 请导航至 TI.com.cn 上的器件产品文件夹。单击右上角的 [通知我](#) 进行注册, 即可每周接收产品信息更改摘要。有关更改的详细信息, 请查看任何已修订文档中包含的修订历史记录。

12.3 社区资源

下列链接提供到 TI 社区资源的连接。链接的内容由各个分销商“按照原样”提供。这些内容并不构成 TI 技术规范, 并且不一定反映 TI 的观点; 请参阅 TI 的《[使用条款](#)》。

TI E2E™ 在线社区 [TI 的工程师对工程师 \(E2E\) 社区](#)。此社区的创建目的在于促进工程师之间的协作。在 e2e.ti.com 中, 您可以咨询问题、分享知识、拓展思路并与同行工程师一道帮助解决问题。

设计支持 [TI 参考设计支持](#) 可帮助您快速查找有帮助的 E2E 论坛、设计支持工具以及技术支持的联系信息。

12.4 商标

E2E is a trademark of Texas Instruments.

12.5 静电放电警告



ESD 可能会损坏该集成电路。德州仪器 (TI) 建议通过适当的预防措施处理所有集成电路。如果不遵守正确的处理措施和安装程序, 可能会损坏集成电路。

ESD 的损坏小至导致微小的性能降级, 大至整个器件故障。精密的集成电路可能更容易受到损坏, 这是因为非常细微的参数更改都可能会导致器件与其发布的规格不相符。

12.6 术语表

[SLYZ022](#) — *TI* 术语表。

这份术语表列出并解释术语、缩写和定义。

13 机械、封装和可订购信息

以下页面包含机械、封装和可订购信息。这些信息是指定器件的最新可用数据。数据如有变更，恕不另行通知，且不会对此文档进行修订。如需获取此产品说明书的浏览器版本，请查阅左侧的导航栏。

PACKAGING INFORMATION

Orderable Device	Status (1)	Package Type	Package Drawing	Pins	Package Qty	Eco Plan (2)	Lead finish/ Ball material (6)	MSL Peak Temp (3)	Op Temp (°C)	Device Marking (4/5)	Samples
SN74AXCH8T245PWR	ACTIVE	TSSOP	PW	24	2000	RoHS & Green	NIPDAU	Level-1-260C-UNLIM	-40 to 125	AH8T245	Samples
SN74AXCH8T245RHLR	ACTIVE	VQFN	RHL	24	3000	RoHS & Green	NIPDAU	Level-1-260C-UNLIM	-40 to 125	AH8T245	Samples

(1) The marketing status values are defined as follows:

ACTIVE: Product device recommended for new designs.

LIFEBUY: TI has announced that the device will be discontinued, and a lifetime-buy period is in effect.

NRND: Not recommended for new designs. Device is in production to support existing customers, but TI does not recommend using this part in a new design.

PREVIEW: Device has been announced but is not in production. Samples may or may not be available.

OBSOLETE: TI has discontinued the production of the device.

(2) **RoHS:** TI defines "RoHS" to mean semiconductor products that are compliant with the current EU RoHS requirements for all 10 RoHS substances, including the requirement that RoHS substance do not exceed 0.1% by weight in homogeneous materials. Where designed to be soldered at high temperatures, "RoHS" products are suitable for use in specified lead-free processes. TI may reference these types of products as "Pb-Free".

RoHS Exempt: TI defines "RoHS Exempt" to mean products that contain lead but are compliant with EU RoHS pursuant to a specific EU RoHS exemption.

Green: TI defines "Green" to mean the content of Chlorine (Cl) and Bromine (Br) based flame retardants meet JS709B low halogen requirements of <=1000ppm threshold. Antimony trioxide based flame retardants must also meet the <=1000ppm threshold requirement.

(3) MSL, Peak Temp. - The Moisture Sensitivity Level rating according to the JEDEC industry standard classifications, and peak solder temperature.

(4) There may be additional marking, which relates to the logo, the lot trace code information, or the environmental category on the device.

(5) Multiple Device Markings will be inside parentheses. Only one Device Marking contained in parentheses and separated by a "~" will appear on a device. If a line is indented then it is a continuation of the previous line and the two combined represent the entire Device Marking for that device.

(6) Lead finish/Ball material - Orderable Devices may have multiple material finish options. Finish options are separated by a vertical ruled line. Lead finish/Ball material values may wrap to two lines if the finish value exceeds the maximum column width.

Important Information and Disclaimer:The information provided on this page represents TI's knowledge and belief as of the date that it is provided. TI bases its knowledge and belief on information provided by third parties, and makes no representation or warranty as to the accuracy of such information. Efforts are underway to better integrate information from third parties. TI has taken and continues to take reasonable steps to provide representative and accurate information but may not have conducted destructive testing or chemical analysis on incoming materials and chemicals. TI and TI suppliers consider certain information to be proprietary, and thus CAS numbers and other limited information may not be available for release.

In no event shall TI's liability arising out of such information exceed the total purchase price of the TI part(s) at issue in this document sold by TI to Customer on an annual basis.

TAPE AND REEL INFORMATION

QUADRANT ASSIGNMENTS FOR PIN 1 ORIENTATION IN TAPE

*All dimensions are nominal

Device	Package Type	Package Drawing	Pins	SPQ	Reel Diameter (mm)	Reel Width W1 (mm)	A0 (mm)	B0 (mm)	K0 (mm)	P1 (mm)	W (mm)	Pin1 Quadrant
SN74AXCH8T245PWR	TSSOP	PW	24	2000	330.0	16.4	6.95	8.3	1.6	8.0	16.0	Q1
SN74AXCH8T245RHLR	VQFN	RHL	24	3000	330.0	12.4	3.8	5.8	1.2	8.0	12.0	Q1

TAPE AND REEL BOX DIMENSIONS

*All dimensions are nominal

Device	Package Type	Package Drawing	Pins	SPQ	Length (mm)	Width (mm)	Height (mm)
SN74AXCH8T245PWR	TSSOP	PW	24	2000	356.0	356.0	35.0
SN74AXCH8T245RHLR	VQFN	RHL	24	3000	367.0	367.0	35.0

PW0024A



PACKAGE OUTLINE
TSSOP - 1.2 mm max height

SMALL OUTLINE PACKAGE



NOTES:

1. All linear dimensions are in millimeters. Any dimensions in parenthesis are for reference only. Dimensioning and tolerancing per ASME Y14.5M.
2. This drawing is subject to change without notice.
3. This dimension does not include mold flash, protrusions, or gate burrs. Mold flash, protrusions, or gate burrs shall not exceed 0.15 mm per side.
4. This dimension does not include interlead flash. Interlead flash shall not exceed 0.25 mm per side.
5. Reference JEDEC registration MO-153.

EXAMPLE BOARD LAYOUT

PW0024A

TSSOP - 1.2 mm max height

SMALL OUTLINE PACKAGE



LAND PATTERN EXAMPLE
EXPOSED METAL SHOWN
SCALE: 10X



SOLDER MASK DETAILS

4220208/A 02/2017

NOTES: (continued)

- 6. Publication IPC-7351 may have alternate designs.
- 7. Solder mask tolerances between and around signal pads can vary based on board fabrication site.

EXAMPLE STENCIL DESIGN

PW0024A

TSSOP - 1.2 mm max height

SMALL OUTLINE PACKAGE



NOTES: (continued)

8. Laser cutting apertures with trapezoidal walls and rounded corners may offer better paste release. IPC-7525 may have alternate design recommendations.
9. Board assembly site may have different recommendations for stencil design.

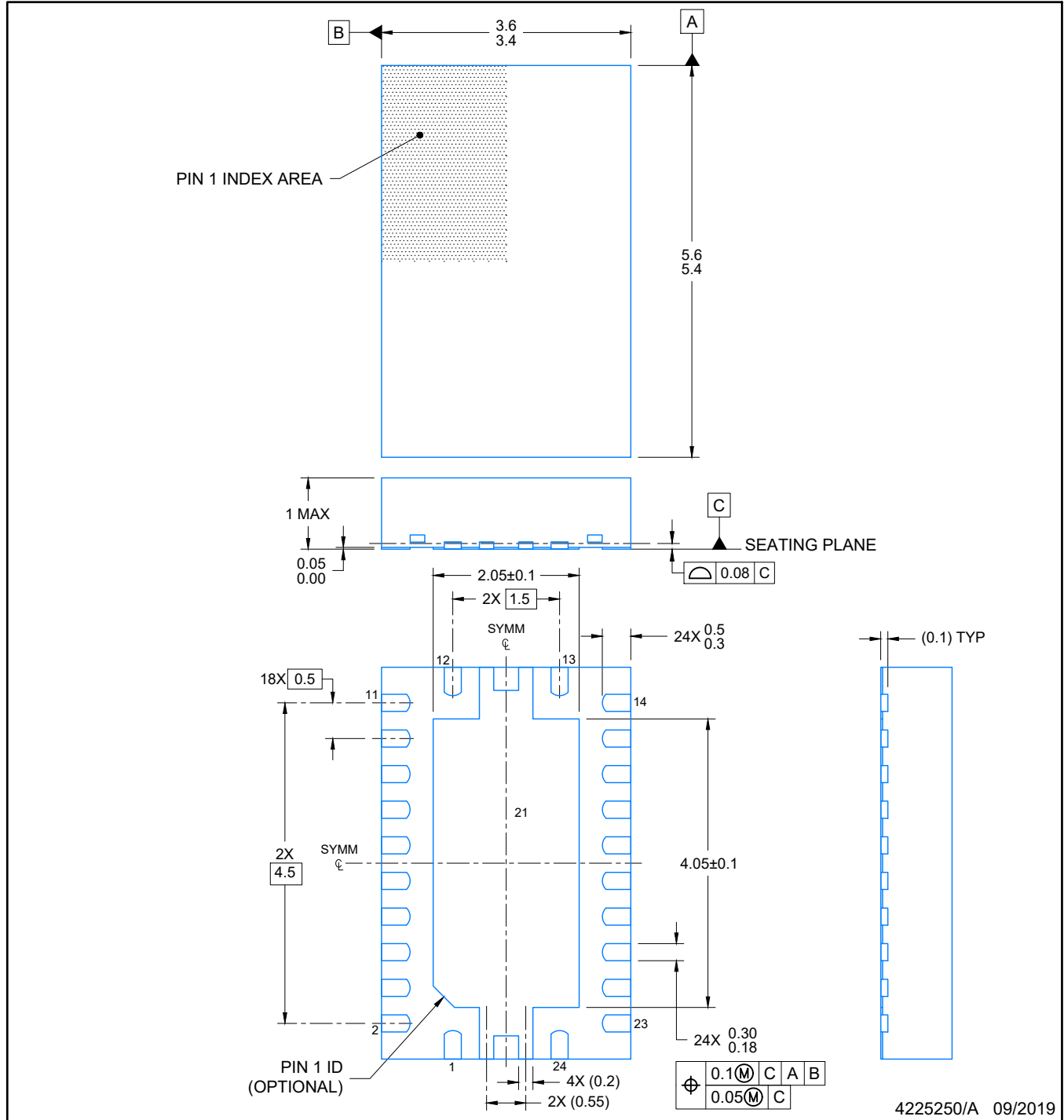

NOTES:

1. All linear dimensions are in millimeters. Any dimensions in parenthesis are for reference only. Dimensioning and tolerancing per ASME Y14.5M.
2. This drawing is subject to change without notice.
3. The package thermal pad must be soldered to the printed circuit board for optimal thermal and mechanical performance.

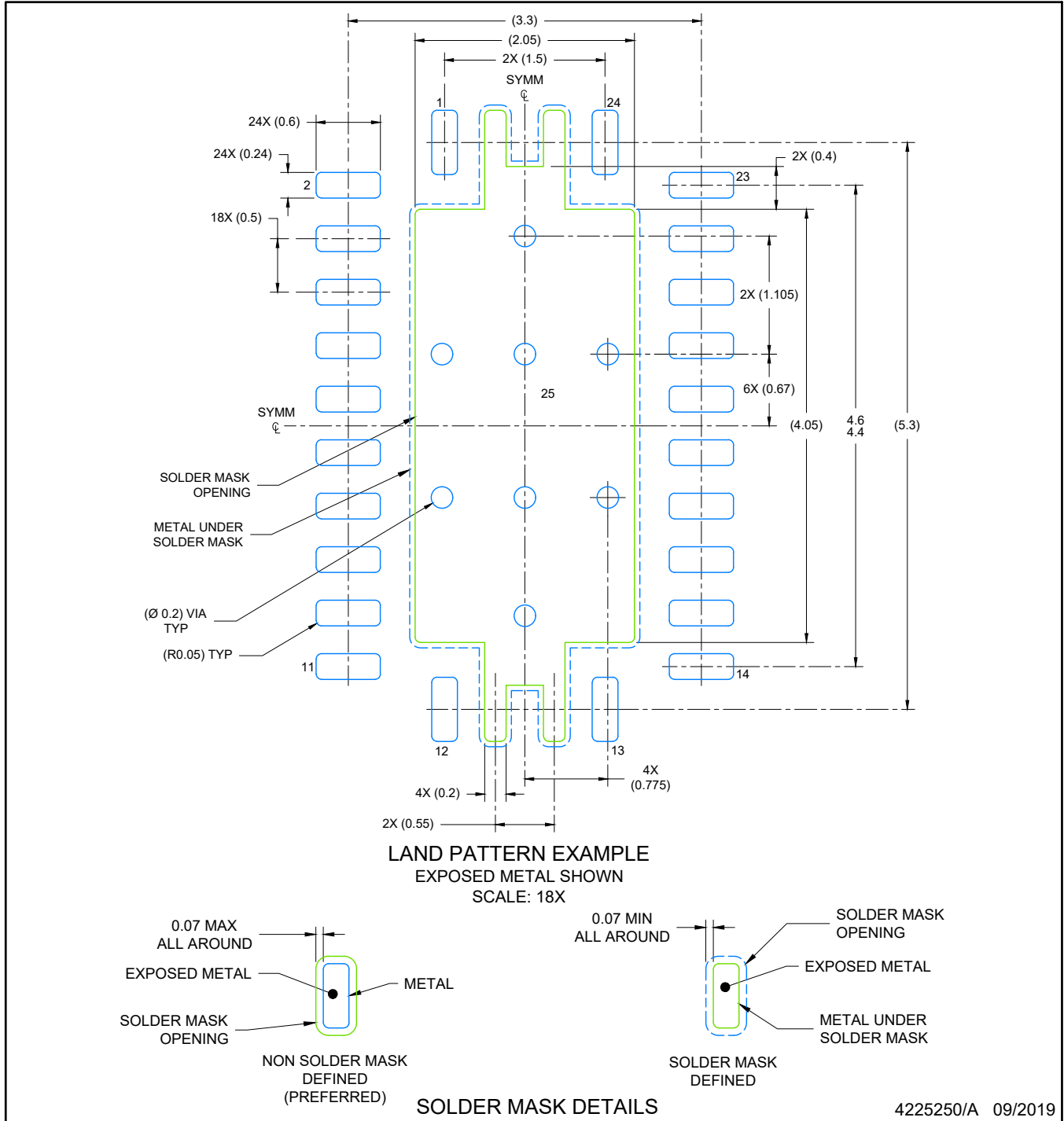

NOTES: (continued)

4. This package is designed to be soldered to a thermal pad on the board. For more information, see Texas Instruments literature number SLUA271 (www.ti.com/lit/slua271).
5. Vias are optional depending on application, refer to device data sheet. If any vias are implemented, refer to their locations shown on this view. It is recommended that vias under paste be filled, plugged or tented.

EXAMPLE STENCIL DESIGN

RHL0024A

VQFN - 1 mm max height

PLASTIC QUAD FLATPACK- NO LEAD

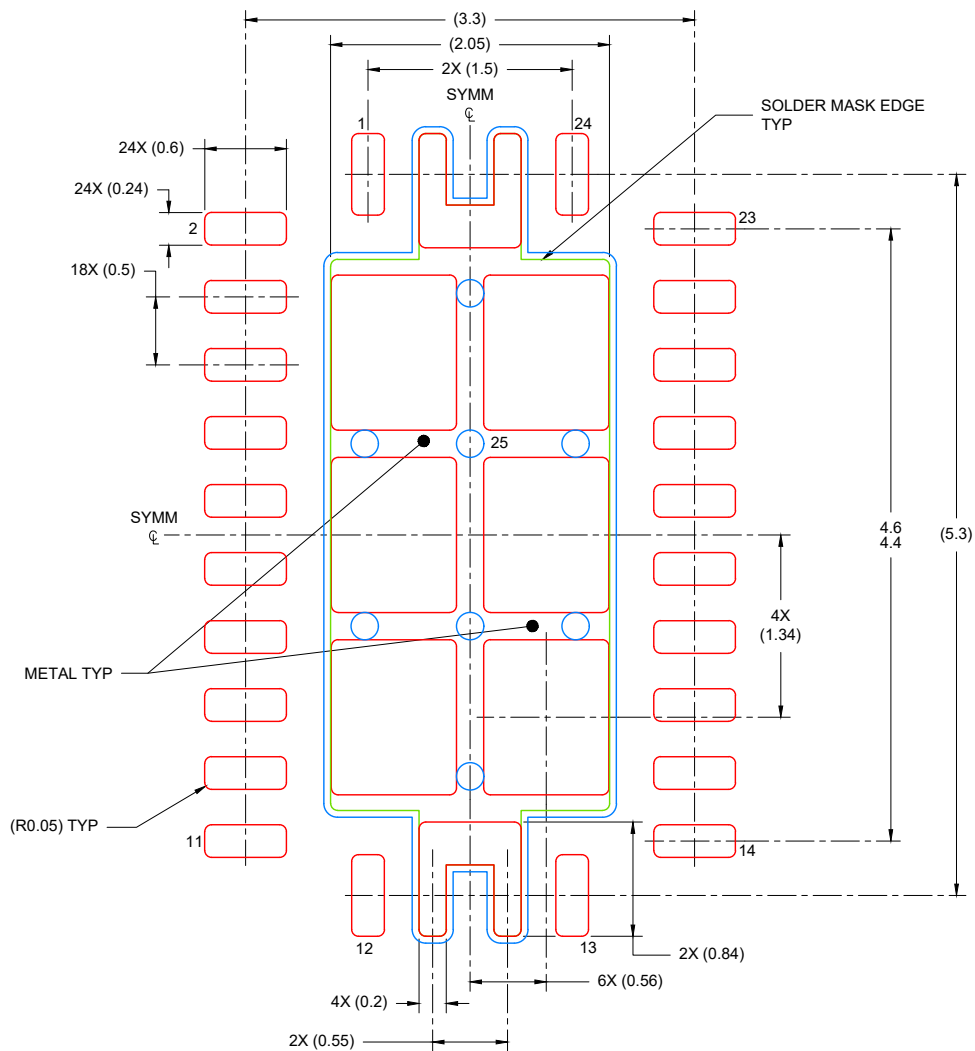

SOLDER PASTE EXAMPLE
BASED ON 0.125 mm THICK STENCIL

EXPOSED PAD
80% PRINTED COVERAGE BY AREA
SCALE: 18X

4225250/A 09/2019

NOTES: (continued)

6. Laser cutting apertures with trapezoidal walls and rounded corners may offer better paste release. IPC-7525 may have alternate design recommendations.

重要声明和免责声明

TI“按原样”提供技术和可靠性数据（包括数据表）、设计资源（包括参考设计）、应用或其他设计建议、网络工具、安全信息和其他资源，不保证没有瑕疵且不做任何明示或暗示的担保，包括但不限于对适销性、某特定用途方面的适用性或不侵犯任何第三方知识产权的暗示担保。

这些资源可供使用 TI 产品进行设计的熟练开发人员使用。您将自行承担以下全部责任：(1) 针对您的应用选择合适的 TI 产品，(2) 设计、验证并测试您的应用，(3) 确保您的应用满足相应标准以及任何其他功能安全、信息安全、监管或其他要求。

这些资源如有变更，恕不另行通知。TI 授权您仅可将这些资源用于研发本资源所述的 TI 产品的应用。严禁对这些资源进行其他复制或展示。您无权使用任何其他 TI 知识产权或任何第三方知识产权。您应全额赔偿因在这些资源的使用中对 TI 及其代表造成的任何索赔、损害、成本、损失和债务，TI 对此概不负责。

TI 提供的产品受 [TI 的销售条款](#) 或 [ti.com](#) 上其他适用条款/TI 产品随附的其他适用条款的约束。TI 提供这些资源并不会扩展或以其他方式更改 TI 针对 TI 产品发布的适用的担保或担保免责声明。

TI 反对并拒绝您可能提出的任何其他或不同的条款。

邮寄地址：Texas Instruments, Post Office Box 655303, Dallas, Texas 75265

Copyright © 2022，德州仪器 (TI) 公司

X-ON Electronics

Largest Supplier of Electrical and Electronic Components

Click to view similar products for [Translation - Voltage Levels](#) category:

Click to view products by [Texas Instruments](#) manufacturer:

Other Similar products are found below :

[NLSX4373DMR2G](#) [NLSX5012MUTAG](#) [NLSX0102FCT1G](#) [PCA9306FMUTAG](#) [MC100EPT622MNG](#) [NLSX3014MUTAG](#)
[NLSX5011MUTCG](#) [NLVSX4373MUTAG](#) [NB3U23CMNTAG](#) [NLSX3013BFCT1G](#) [NLV7WBD3125USG](#) [NLSX3012DMR2G](#)
[NLA9306MU3TCG](#) [PI4ULS3V304AZMAEX](#) [PI4ULS3V504AZMAEX](#) [74AVCH1T45FW3-7](#) [NLSX5011AMUTAG](#) [74AXP1T34GWH](#)
[ST2149BQTR](#) [MC100ELT21DR2G](#) [MC100LVELT22MNRG](#) [MC10ELT20DR2G](#) [MC10EPT20MNR4G](#) [MC14504BFELG](#)
[NLSV4T3234FCT1G](#) [NLSX3378BFCT1G](#) [UM3208QA](#) [UM3208H](#) [UM3304](#) [UM3304QT](#) [UM3202H](#) [UM3308](#) [RS0104YTQE12](#)
[RS0204YUTQH12](#) [AW39204QNR](#) [AW39114FOR](#) [RS0104YTQF14](#) [RS0204YTQF14](#) [UM3204QT](#) [UM3204QB](#) [UM3204QV](#)
[AIPTS0104TA14.TR](#) [AIPTB0104TA14.TR](#) [UM3304QS](#) [SN74LXC2T45DCUR](#) [TCA39306DTMR](#) [NTS0102TL-Q100H](#) [AW39112DNR](#)
[XP7660](#) [RS4T774XTSS16](#)