

SN54273, SN54LS273, SN74273, SN74LS273 OCTAL D-TYPE FLIP-FLOP WITH CLEAR

SDLS090 – OCTOBER 1976 – REVISED MARCH 1988

- Contains Eight Flip-Flops With Single-Rail Outputs
- Buffered Clock and Direct Clear Inputs
- Individual Data Input to Each Flip-Flop
- Applications Include:
 - Buffer/Storage Registers
 - Shift Registers
 - Pattern Generators

description

These monolithic, positive-edge-triggered flip-flops utilize TTL circuitry to implement D-type flip-flop logic with a direct clear input.

Information at the D inputs meeting the setup time requirements is transferred to the Q outputs on the positive-going edge of the clock pulse. Clock triggering occurs at a particular voltage level and is not directly related to the transition time of the positive-going pulse. When the clock input is at either the high or low level, the D input signal has no effect at the output.

These flip-flops are guaranteed to respond to clock frequencies ranging from 0 to 30 megahertz while maximum clock frequency is typically 40 megahertz. Typical power dissipation is 39 milliwatts per flip-flop for the '273 and 10 milliwatts for the 'LS273.

SN54273, SN74LS273 . . . J OR W PACKAGE
SN74273 . . . N PACKAGE
SN74LS273 . . . DW OR N PACKAGE
(TOP VIEW)

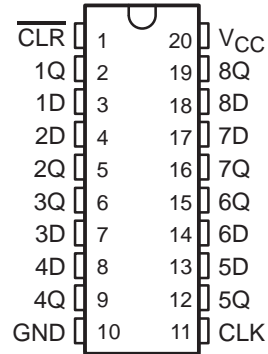

SN54LS273 . . . FK PACKAGE
(TOP VIEW)

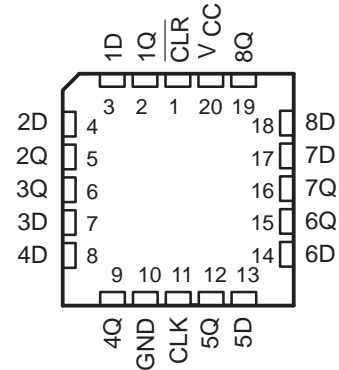

FUNCTION TABLE
(each flip-flop)

| INPUTS | | | OUTPUT |
|--------|-------|---|----------------|
| CLEAR | CLOCK | D | Q |
| L | X | X | L |
| H | ↑ | H | H |
| H | ↑ | L | L |
| H | L | X | Q ₀ |

logic symbol†

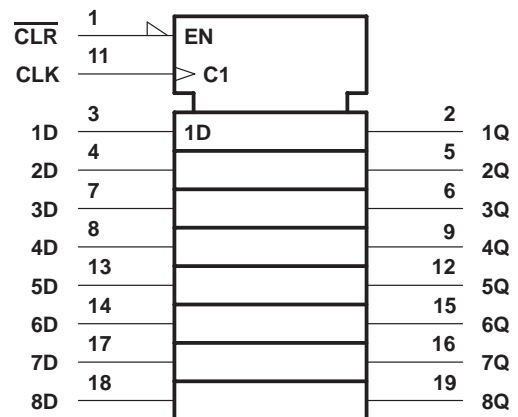

† This symbol is in accordance with ANSI/IEEE Std. 91-1984 and IEC Publication 617-12. Pin numbers shown are for the DW, J, N, and W packages.

SN54273, SN54LS273, SN74273, SN74LS273 OCTAL D-TYPE FLIP-FLOP WITH CLEAR

SDLS090 – OCTOBER 1976 – REVISED MARCH 1988

schematics of inputs and outputs

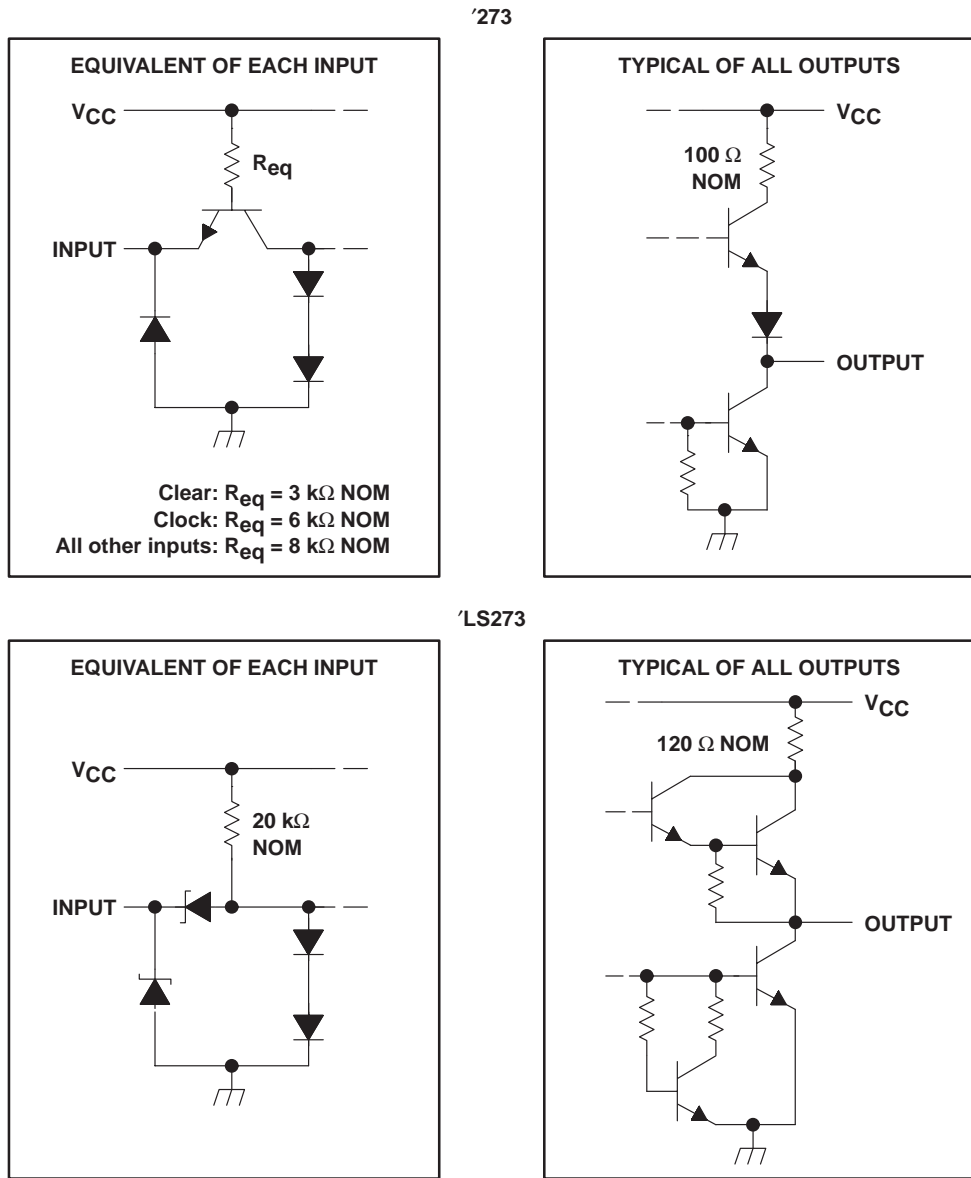

logic diagram (positive logic)

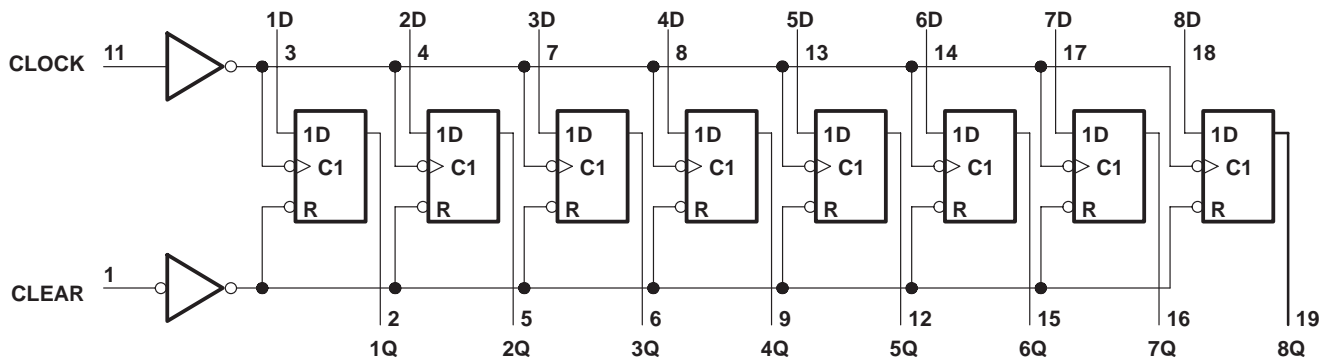

Pin numbers shown are for the DW, J, N, and W packages.

SN54273, SN54LS273, SN74273, SN74LS273 OCTAL D-TYPE FLIP-FLOP WITH CLEAR

SDLS090 – OCTOBER 1976 – REVISED MARCH 1988

absolute maximum ratings over operating free-air temperature range (unless otherwise noted)

| | |
|---|----------------|
| Supply voltage, V_{CC} (see Note 1) | 7 V |
| Input voltage | 5.5 V |
| Operating free-air temperature range, T_A : SN54273 | -55°C to 125°C |
| SN74273 | 0°C to 70°C |
| Storage temperature range | -65°C to 150°C |

NOTE 1: Voltage values are with respect to network ground terminal.

recommended operating conditions

| | SN54273 | | | SN74273 | | | UNIT |
|---------------------------------------|----------------------|---------------|------|---------------|-----|------|---------|
| | MIN | NOM | MAX | MIN | NOM | MAX | |
| Supply voltage, V_{CC} | 4.5 | 5 | 5.5 | 4.75 | 5 | 5.25 | V |
| High-level output current, I_{OH} | | | -800 | | | -800 | μ A |
| Low-level output current, I_{OL} | | | 16 | | | 16 | mA |
| Clock frequency, f_{clock} | 0 | | 30 | 0 | | 30 | MHz |
| Width of clock or clear pulse, t_w | 16.5 | | | 16.5 | | | ns |
| Setup time, t_{su} | Data input | 20 \uparrow | | 20 \uparrow | | | ns |
| | Clear inactive state | 25 \uparrow | | 25 \uparrow | | | |
| Data hold time, t_h | 5 \uparrow | | | 5 \uparrow | | | ns |
| Operating free-air temperature, T_A | -55 | | 125 | 0 | | 70 | °C |

\uparrow The arrow indicates that the rising edge of the clock pulse is used for reference.

electrical characteristics over recommended operating free-air temperature range (unless otherwise noted)

| PARAMETER | | TEST CONDITIONS \dagger | MIN | TYP \ddagger | MAX | UNIT |
|-----------|--|--|--|----------------|------|---------|
| V_{IH} | High-level input voltage | | 2 | | | V |
| V_{IL} | Low-level input voltage | | | | 0.8 | V |
| V_{IK} | Input clamp voltage | $V_{CC} = \text{MIN}$, $I_I = -12 \text{ mA}$ | | | -1.5 | V |
| V_{OH} | High-level output voltage | $V_{CC} = \text{MIN}$, $V_{IL} = 0.8 \text{ V}$, $I_{OH} = -800 \mu\text{A}$ | 2.4 | 3.4 | | V |
| V_{OL} | Low-level output voltage | $V_{CC} = \text{MIN}$, $V_{IL} = 0.8 \text{ V}$, $I_{OH} = 16 \text{ mA}$ | | | 0.4 | V |
| I_I | Input current at maximum input voltage | $V_{CC} = \text{MAX}$, $V_I = 5.5 \text{ V}$ | | | 1 | mA |
| I_{IH} | High-level input current | Clear | | | 80 | μ A |
| | | Clock or D | $V_{CC} = \text{MAX}$, $V_I = 2.4 \text{ V}$ | | 40 | |
| I_{IL} | Low-level input current | Clear | | | -3.2 | mA |
| | | Clock or D | $V_{CC} = \text{MAX}$, $V_I = 0.4 \text{ V}$ | | -1.6 | |
| I_{OS} | Short-circuit output current \S | $V_{CC} = \text{MAX}$ | -18 | | -57 | mA |
| I_{CC} | Supply current | $V_{CC} = \text{MAX}$, See Note 2 | | 62 | 94 | mA |

\dagger For conditions shown as MIN or MAX, use the appropriate value specified under recommended operating conditions.

\ddagger All typical values are at $V_{CC} = 5 \text{ V}$, $T_A = 25^\circ\text{C}$.

\S Not more than one output should be shorted at a time.

NOTE 2: With all outputs open and 4.5 V applied to all data and clear inputs, I_{CC} is measured after a momentary ground, then 4.5 V, is applied to clock.

SN54273, SN54LS273, SN74273, SN74LS273 OCTAL D-TYPE FLIP-FLOP WITH CLEAR

SDLS090 – OCTOBER 1976 – REVISED MARCH 1988

switching characteristics, $V_{CC} = 5\text{ V}$, $T_A = 25^\circ\text{C}$

| PARAMETER | TEST CONDITIONS | MIN | TYP | MAX | UNIT |
|---|---|-----|-----|-----|------|
| f_{\max} Maximum clock frequency | $C_L = 15\text{ pF}$, $R_L = 400\ \Omega$, See Note 3 | 30 | 40 | | MHz |
| t_{PHL} Propagation delay time, high-to-low-level output from clear | | | 18 | 27 | ns |
| t_{PLH} Propagation delay time, low-to-high-level output from clock | | | 17 | 27 | ns |
| t_{PHL} Propagation delay time, high-to-low-level output from clock | | | 18 | 27 | ns |

NOTE 3: Load circuits and voltage waveforms are shown in Section 1.

absolute maximum ratings over operating free-air temperature range (unless otherwise noted)

| | |
|---|--|
| Supply voltage, V_{CC} (see Note 1) | 7 V |
| Input voltage | 7 V |
| Operating free-air temperature range, T_A : SN54LS273 | -55°C to 125°C |
| SN74LS273 | 0°C to 70°C |
| Storage temperature range | -65°C to 150°C |

NOTE 1: Voltage values are with respect to network ground terminal.

recommended operating conditions

| | SN54LS273 | | | SN74LS273 | | | UNIT |
|---------------------------------------|----------------------|-----|------|---------------|-----|------|------------------|
| | MIN | NOM | MAX | MIN | NOM | MAX | |
| Supply voltage, V_{CC} | 4.5 | 5 | 5.5 | 4.75 | 5 | 5.25 | V |
| High-level output current, I_{OH} | | | -400 | | | -400 | μA |
| Low-level output current, I_{OL} | | | 4 | | | 8 | mA |
| Clock frequency, f_{clock} | 0 | | 30 | 0 | | 30 | MHz |
| Width of clock or clear pulse, t_w | 20 | | | 20 | | | ns |
| Setup time, t_{su} | Data input | | | 20 \uparrow | | | ns |
| | Clear inactive state | | | 25 \uparrow | | | |
| Data hold time, t_h | 5 \uparrow | | | 5 \uparrow | | | ns |
| Operating free-air temperature, T_A | -55 | | 125 | 0 | | 70 | $^\circ\text{C}$ |

\uparrow The arrow indicates that the rising edge of the clock pulse is used for reference.

SN54273, SN54LS273, SN74273, SN74LS273 OCTAL D-TYPE FLIP-FLOP WITH CLEAR

SDLS090 – OCTOBER 1976 – REVISED MARCH 1988

electrical characteristics over recommended operating free-air temperature range (unless otherwise noted)

| PARAMETER | TEST CONDITIONST | SN54LS273 | | | SN74LS273 | | | UNIT |
|---|--|-----------|------|------|-----------|------|------|------|
| | | MIN | TYP‡ | MAX | MIN | TYP‡ | MAX | |
| V _{IH} High-level input voltage | | 2 | | | 2 | | | V |
| V _{IL} Low-level input voltage | | | | 0.7 | | | 0.8 | V |
| V _{IK} Input clamp voltage | V _{CC} = MIN, I _I = -18 mA | | | -1.5 | | | -1.5 | V |
| V _{OH} High-level output voltage | V _{CC} = MIN, V _{IH} = 2 V, V _{IL} = V _{ILmax} , I _{OH} = -400 μA | 2.5 | 3.4 | | 2.7 | 3.4 | | V |
| V _{OL} Low-level output voltage | V _{CC} = MIN, V _{IH} = 2 V, V _{IL} = V _{ILmax} , I _{OL} = 4 mA | 0.25 | 0.4 | | 0.25 | 0.4 | | V |
| | | | | | 0.35 | 0.5 | | |
| I _I Input current at maximum input voltage | V _{CC} = MAX, V _I = 7 V | | | 0.1 | | | 0.1 | mA |
| I _{IH} High-level input current | V _{CC} = MAX, V _I = 2.7 V | | | 20 | | | 20 | μA |
| I _{IL} Low-level input current | V _{CC} = MAX, V _I = 0.4 V | | | -0.4 | | | -0.4 | mA |
| I _{OS} Short-circuit output current§ | V _{CC} = MAX | -20 | | -100 | -20 | | -100 | mA |
| I _{CC} Supply current | V _{CC} = MAX, See Note 2 | | 17 | 27 | | 17 | 27 | mA |

† For conditions shown as MIN or MAX, use the appropriate value specified under recommended operating conditions.

‡ All typical values are at V_{CC} = 5 V, T_A = 25°C.

§ Not more than one output should be shorted at a time and duration of short circuit should not exceed one second.

NOTE 2: With all outputs open and 4.5 V applied to all data and clear inputs, I_{CC} is measured after a momentary ground, then 4.5 V, is applied to clock.

switching characteristics, V_{CC} = 5 V, T_A = 25°C

| PARAMETER | TEST CONDITIONS | MIN | TYP | MAX | UNIT |
|--|---|-----|-----|-----|------|
| f _{max} Maximum clock frequency | C _L = 15 pF, R _L = 2 kΩ, See Note 3 | 30 | 40 | | MHz |
| t _{PHL} Propagation delay time, high-to-low-level output from clear | | | 18 | 27 | ns |
| t _{PLH} Propagation delay time, low-to-high-level output from clock | | | 17 | 27 | ns |
| t _{PHL} Propagation delay time, high-to-low-level output from clock | | | 18 | 27 | ns |

NOTE 3: Load circuits and voltage waveforms are shown in Section 1.



TAPE AND REEL INFORMATION

QUADRANT ASSIGNMENTS FOR PIN 1 ORIENTATION IN TAPE

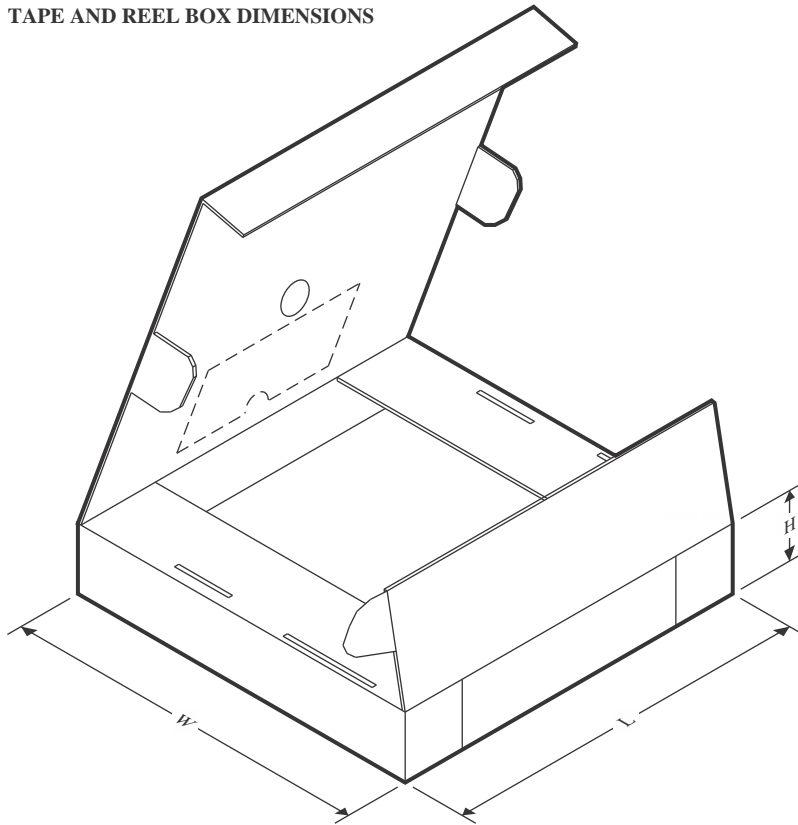

*All dimensions are nominal

| Device | Package Type | Package Drawing | Pins | SPQ | Reel Diameter (mm) | Reel Width W1 (mm) | A0 (mm) | B0 (mm) | K0 (mm) | P1 (mm) | W (mm) | Pin1 Quadrant |
|--------------|--------------|-----------------|------|------|--------------------|--------------------|---------|---------|---------|---------|--------|---------------|
| SN74LS273DWR | SOIC | DW | 20 | 2000 | 330.0 | 24.4 | 10.8 | 13.3 | 2.7 | 12.0 | 24.0 | Q1 |
| SN74LS273NSR | SO | NS | 20 | 2000 | 330.0 | 24.4 | 8.4 | 13.0 | 2.5 | 12.0 | 24.0 | Q1 |

TAPE AND REEL BOX DIMENSIONS

*All dimensions are nominal

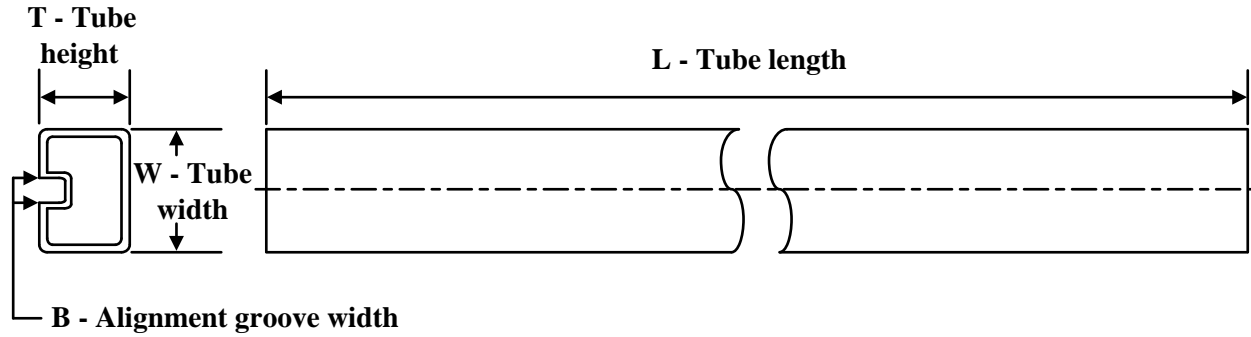
| Device | Package Type | Package Drawing | Pins | SPQ | Length (mm) | Width (mm) | Height (mm) |
|--------------|--------------|-----------------|------|------|-------------|------------|-------------|
| SN74LS273DWR | SOIC | DW | 20 | 2000 | 367.0 | 367.0 | 45.0 |
| SN74LS273NSR | SO | NS | 20 | 2000 | 367.0 | 367.0 | 45.0 |

TUBE

*All dimensions are nominal

| Device | Package Name | Package Type | Pins | SPQ | L (mm) | W (mm) | T (μm) | B (mm) |
|------------------|--------------|--------------|------|-----|--------|--------|--------|--------|
| 78010012A | FK | LCCC | 20 | 1 | 506.98 | 12.06 | 2030 | NA |
| 7801001SA | W | CFP | 20 | 1 | 506.98 | 26.16 | 6220 | NA |
| JM38510/32501B2A | FK | LCCC | 20 | 1 | 506.98 | 12.06 | 2030 | NA |
| JM38510/32501BSA | W | CFP | 20 | 1 | 506.98 | 26.16 | 6220 | NA |
| M38510/32501B2A | FK | LCCC | 20 | 1 | 506.98 | 12.06 | 2030 | NA |
| M38510/32501BSA | W | CFP | 20 | 1 | 506.98 | 26.16 | 6220 | NA |
| SN74LS273DW | DW | SOIC | 20 | 25 | 507 | 12.83 | 5080 | 6.6 |
| SN74LS273N | N | PDIP | 20 | 20 | 506 | 13.97 | 11230 | 4.32 |
| SN74LS273NE4 | N | PDIP | 20 | 20 | 506 | 13.97 | 11230 | 4.32 |
| SNJ54LS273FK | FK | LCCC | 20 | 1 | 506.98 | 12.06 | 2030 | NA |
| SNJ54LS273W | W | CFP | 20 | 1 | 506.98 | 26.16 | 6220 | NA |

IMPORTANT NOTICE AND DISCLAIMER

TI PROVIDES TECHNICAL AND RELIABILITY DATA (INCLUDING DATA SHEETS), DESIGN RESOURCES (INCLUDING REFERENCE DESIGNS), APPLICATION OR OTHER DESIGN ADVICE, WEB TOOLS, SAFETY INFORMATION, AND OTHER RESOURCES "AS IS" AND WITH ALL FAULTS, AND DISCLAIMS ALL WARRANTIES, EXPRESS AND IMPLIED, INCLUDING WITHOUT LIMITATION ANY IMPLIED WARRANTIES OF MERCHANTABILITY, FITNESS FOR A PARTICULAR PURPOSE OR NON-INFRINGEMENT OF THIRD PARTY INTELLECTUAL PROPERTY RIGHTS.

These resources are intended for skilled developers designing with TI products. You are solely responsible for (1) selecting the appropriate TI products for your application, (2) designing, validating and testing your application, and (3) ensuring your application meets applicable standards, and any other safety, security, regulatory or other requirements.

These resources are subject to change without notice. TI grants you permission to use these resources only for development of an application that uses the TI products described in the resource. Other reproduction and display of these resources is prohibited. No license is granted to any other TI intellectual property right or to any third party intellectual property right. TI disclaims responsibility for, and you will fully indemnify TI and its representatives against, any claims, damages, costs, losses, and liabilities arising out of your use of these resources.

TI's products are provided subject to [TI's Terms of Sale](#) or other applicable terms available either on ti.com or provided in conjunction with such TI products. TI's provision of these resources does not expand or otherwise alter TI's applicable warranties or warranty disclaimers for TI products.

TI objects to and rejects any additional or different terms you may have proposed.

Mailing Address: Texas Instruments, Post Office Box 655303, Dallas, Texas 75265
Copyright © 2022, Texas Instruments Incorporated

X-ON Electronics

Largest Supplier of Electrical and Electronic Components

Click to view similar products for [Flip-Flops](#) category:

Click to view products by [Texas Instruments](#) manufacturer:

Other Similar products are found below :

[NLV74HC74ADTR2G](#) [74F574SC](#) [TC7W74FUTE12LF](#) [NLV14013BDR2G](#) [NLV74HC74ADR2G](#) [MC10EP131MNG](#) [MC74AC74DTR2](#)
[74VHC574FT\(BJ\)](#) [HT4093ARZ](#) [SN74HC374ANSR](#) [CD4528BE](#) [CD4027BE](#) [RS74HC74XQ](#) [RS74HC74XP](#) [RS574XTSS20](#) [CD40106BM-](#)
[JSM](#) [74HCT273PW-Q100J](#) [SN74ABT273PWRE4](#) [CLVC2G74QDCURG4Q1](#) [CD4067TA24.TB](#) [CD4013SA.TR](#) [AIP74HCT14TA14.TB](#)
[HSN74LVC1G14DBVR](#) [CD4013BPWRG](#) [AiP74LVC74TA14.TB](#) [CD4013BDRG](#) [CD4528SA16.TR](#) [AIP74HC273SA.TB](#)
[SN74HCS74QDYRQ1](#) [CD4013TA14.TB](#) [SN74LS107N](#) [SN74LS374DWR](#) [SN74LVC2G14DC\(LX\)](#) [MC74HC73ADG](#) [MC74HC73ADR2G](#)
[74LCX16374MTDX](#) [74LVT74D,118](#) [74VHCT9273FT\(BJ\)](#) [MM74HC374WM](#) [MM74HC74AMX](#) [74ALVCH162374PAG](#)
[74LVC1G175GS,132](#) [74LVX74MTCX](#) [TC7WZ74FK,LJ\(CT](#) [MM74HCT273WM](#) [SN74LVC74AD](#) [SN74HC273DWR](#) [M74HC374RM13TR](#)
[M74HC175B1R](#) [M74HC174RM13TR](#)