

SN74LV14A 六路施密特触发反相器

1 特性

- V_{CC} 工作电压范围为 2V 至 5.5V
- 5V 时 t_{pd} 最大值为 10ns
- $V_{CC} = 3.3V$ 、 $T_A = 25^\circ C$ 时， V_{OLP} (输出接地反弹) 典型值小于 0.8V
- $V_{CC} = 3.3V$ 、 $T_A = 25^\circ C$ 时， V_{OHV} (输出 V_{OH} 下冲) 典型值大于 2.3V
- 所有端口上均支持以混合模式电压运行
- I_{off} 支持局部断电模式运行
- 闩锁性能超过 250mA，符合 JESD 17 规范的要求

2 应用

- 网络交换机
- 可穿戴保健和健身设备
- PDA
- LCD 电视
- 电力基础设施

3 描述

这些六路施密特触发反相器需在 2V 至 5.5V V_{CC} 下运行。

SN74LV14A 器件包含六个独立的反相器。这些器件执行布尔函数 $Y = \bar{A}$ 。

封装信息

器件型号	封装 ⁽¹⁾	封装尺寸 (标称值)
SN74LV14A	TVSOP (14)	3.60mm × 4.40mm
	SOIC (14)	8.65mm × 3.91mm
	SSOP (14)	6.20mm × 5.30mm
	TSSOP (14)	5.00mm × 4.40mm

(1) 如需了解所有可用封装，请参阅数据表末尾的可订购产品附录。



图 3-1. 简化原理图



Table of Contents

1 特性	1	8.1 Overview.....	9
2 应用	1	8.2 Functional Block Diagram.....	9
3 描述	1	8.3 Feature Description.....	9
4 Revision History	2	8.4 Device Functional Modes.....	9
5 Pin Configuration and Functions	3	9 Application and Implementation	10
Pin Functions.....	3	9.1 Application Information.....	10
6 Specifications	4	9.2 Typical Application.....	10
6.1 Absolute Maximum Ratings.....	4	10 Power Supply Recommendations	12
6.2 ESD Ratings.....	4	11 Layout	12
6.3 Recommended Operating Conditions.....	4	11.1 Layout Guidelines.....	12
6.4 Thermal Information.....	5	11.2 Layout Example.....	12
6.5 Electrical Characteristics.....	5	12 Device and Documentation Support	13
6.6 Switching Characteristics, $V_{CC} = 2.5\text{ V} \pm 0.2\text{ V}$	6	12.1 Related Links.....	13
6.7 Switching Characteristics, $V_{CC} = 3.3\text{ V} \pm 0.3\text{ V}$	6	12.2 接收文档更新通知.....	13
6.8 Switching Characteristics, $V_{CC} = 5\text{ V} \pm 0.5\text{ V}$	6	12.3 支持资源.....	13
6.9 Noise Characteristics.....	6	12.4 Trademarks.....	13
6.10 Operating Characteristics.....	6	12.5 Electrostatic Discharge Caution.....	13
6.11 Typical Characteristics.....	7	12.6 术语表.....	13
7 Parameter Measurement Information	8	13 Mechanical, Packaging, and Orderable Information	13
8 Detailed Description	9		

4 Revision History

Changes from Revision K (September 2014) to Revision L (December 2022)	Page
• 通篇更新了表格、图和交叉参考的格式.....	1

Changes from Revision J (September 1997) to Revision K (September 2014)	Page
• 将文档更新为新的 TI 数据表格式.....	1
• 删除了“订购信息”表.....	1
• 添加了“应用”.....	1
• 添加了“器件信息”表.....	1
• Added Pin Functions table.....	3
• Changed MAX operating temperature to 125°C in Recommended Operating Conditions table.	4
• Added Thermal Information table.....	5
• Added Typical Characteristics.....	7
• Added Application and Implementation section.....	10
• Added Power Supply Recommendations and Layout sections.....	12

5 Pin Configuration and Functions



图 5-1. SN74LV14A D, DB, DGV, NS OR PW Package Top View



图 5-2. SN74LV14A RGY Package Top View

Pin Functions

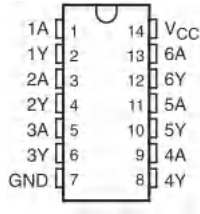
NAME	PIN		TYPE ⁽¹⁾	DESCRIPTION
	SN74LV14A			
	D, DB, DGV, NS, PW	RGY		
1A	1	1	I	Input 1A
1Y	2	2	O	Output 1Y
2A	3	3	I	Input 2A
2Y	4	4	O	Output 2Y
3A	5	5	I	Input 3A
3Y	6	6	O	Output 3Y
4Y	8	8	O	Output 4Y
4A	9	9	I	Input 4A
5Y	10	10	O	Output 5Y
5A	11	11	I	Input 5A
6Y	12	12	O	Output 6Y
6A	13	13	I	Input 6A
GND	7	7	—	Ground Pin
NC	—	—	—	No Connection
V _{CC}	14	14	—	Power Pin

(1) Signal Types: I = Input, O = Output, I/O = Input or Output.

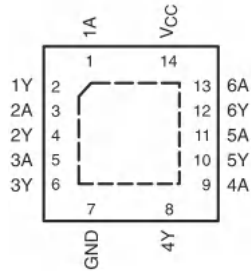
6 Specifications

6.1 Absolute Maximum Ratings

over operating free-air temperature range (unless otherwise noted)⁽¹⁾

		MIN	MAX	UNIT
V _{CC}	Supply voltage range	- 0.5	7	V
V _I	Input voltage range ⁽²⁾	- 0.5	7	V
V _O	Voltage range applied to any output in the high-impedance or power-off state ⁽²⁾	- 0.5	7	V
V _O	Output voltage range ^{(2) (3)}	- 0.5	V _{CC} + 0.5	V
I _{IK}	Input clamp current	V _I < 0	- 20	mA
I _{OK}	Output clamp current	V _O < 0	- 50	mA
I _O	Continuous output current	V _O = 0 to V _{CC}	±25	mA
	Continuous current through V _{CC} or GND		±50	mA
T _J	Junction temperature		150	°C
T _{stg}	Storage temperature range	- 65	150	°C

- (1) Stresses beyond those listed under # 6.1 may cause permanent damage to the device. These are stress ratings only, and functional operation of the device at these or any other conditions beyond those indicated under # 6.3 is not implied. Exposure to absolute-maximum-rated conditions for extended periods may affect device reliability.
- (2) The input and output negative-voltage ratings may be exceeded if the input and output current ratings are observed.
- (3) This value is limited to 5.5-V maximum.

6.2 ESD Ratings

		VALUE	UNIT
V _(ESD)	Electrostatic discharge	Human body model (HBM), per ANSI/ESDA/JEDEC JS-001, all pins ⁽¹⁾	±2000
		Charged device model (CDM), per JEDEC specification JESD22-C101, all pins ⁽²⁾	±1000
		Machine Model	±200

- (1) JEDEC document JEP155 states that 500-V HBM allows safe manufacturing with a standard ESD control process.
- (2) JEDEC document JEP157 states that 250-V CDM allows safe manufacturing with a standard ESD control process.

6.3 Recommended Operating Conditions

over operating free-air temperature range (unless otherwise noted)⁽¹⁾

		SN74LV14A		UNIT
		MIN	MAX	
V _{CC}	Supply voltage	2	5.5	V
V _I	Input voltage	0	5.5	V
V _O	Output voltage	0	V _{CC}	V
I _{OH}	High-level output current	V _{CC} = 2 V	- 50	μA
		V _{CC} = 2.3 V to 2.7 V	- 2	mA
		V _{CC} = 3 V to 3.6 V	- 6	
		V _{CC} = 4.5 V to 5.5 V	- 12	
I _{OL}	Low-level output current	V _{CC} = 2 V	50	μA
		V _{CC} = 2.3 V to 2.7 V	2	mA
		V _{CC} = 3 V to 3.6 V	6	
		V _{CC} = 4.5 V to 5.5 V	12	
T _A	Operating free-air temperature	- 40	125	°C

- (1) All unused inputs of the device must be held at V_{CC} or GND to ensure proper device operation. Refer to the TI application report, *Implications of Slow or Floating CMOS Inputs (SCBA004)*.

6.4 Thermal Information

THERMAL METRIC ⁽¹⁾		SN74LV14A						UNIT
		D	DB	DGV	NS	PW	RGY	
		14 PINS						
$R_{\theta JA}$	Junction-to-ambient thermal resistance	94.9	107.4	130.4	91.4	122.6	57.6	°C/W
$R_{\theta JC(top)}$	Junction-to-case (top) thermal resistance	56.3	59.9	53.4	49.0	51.3	70.4	
$R_{\theta JB}$	Junction-to-board thermal resistance	49.2	54.7	63.5	50.2	64.4	33.6	
ψ_{JT}	Junction-to-top characterization parameter	20.7	21.0	7.3	15.3	6.8	3.5	
ψ_{JB}	Junction-to-board characterization parameter	48.9	51.2	62.8	49.8	63.8	33.7	
$R_{\theta JC(bot)}$	Junction-to-case (bottom) thermal resistance	-	-	-	-	-	14.1	

(1) For more information about traditional and new thermal metrics, see the *IC Package Thermal Metrics* application report (SPRA953).

6.5 Electrical Characteristics

over recommended operating free-air temperature range (unless otherwise noted)

PARAMETER		TEST CONDITIONS	V_{CC}	SN74LV14A - 40°C to 85°C			SN74LV14A - 40°C to 125°C			UNIT
				MIN	TYP	MAX	MIN	TYP	MAX	
V_{T+}	Positive-going threshold		2.5 V				1.75			V
			3.3 V				2.31			
			5 V				3.5			
V_{T-}	Negative-going threshold		2.5 V	0.75			0.75			V
			3.3 V	0.99			0.99			
			5 V	1.5			1.5			
$\Delta V_T (V_{T+} - V_{T-})$	Hysteresis		2.5 V	0.25			0.25			V
			3.3 V	0.33			0.33			
			5 V	0.5			0.5			
V_{OH}	High-level output voltage	$I_{OH} = -50 \mu A$	2 V to 5.5 V	$V_{CC} - 0.1$			$V_{CC} - 0.1$			V
		$I_{OH} = -2 mA$	2.3 V	2			2			
		$I_{OH} = -6 mA$	3 V	2.48			2.48			
		$I_{OH} = -12 mA$	4.5 V	3.8			3.8			
V_{OL}	Low-level output voltage	$I_{OL} = 50 \mu A$	2 V to 5.5 V	0.1			0.1			V
		$I_{OL} = 2 mA$	2.3 V	0.4			0.4			
		$I_{OL} = 6 mA$	3 V	0.44			0.44			
		$I_{OL} = 12 mA$	4.5 V	0.55			0.55			
I_I	Input leakage current	$V_I = V_{CC}$ or GND	0 to 5.5 V	± 1			± 1			μA
I_{CC}	Static supply current	$V_I = V_{CC}$ or GND, $I_O = 0$	5.5 V	20			20			μA
I_{off}	Input/Output Power-Off Leakage Current	V_I or $V_O = 0$ to 5.5 V	0	5			5			μA
C_i	Input capacitance	$V_I = V_{CC}$ or GND	3.3 V	2.3			2.3			pF
			5 V	2.3			2.3			

6.6 Switching Characteristics, $V_{CC} = 2.5\text{ V} \pm 0.2\text{ V}$

over recommended operating free-air temperature range (unless otherwise noted) (see 图 7-1)

PARAMETER	FROM (INPUT)	TO (OUTPUT)	LOAD CAPACITANCE	$T_A = 25^\circ\text{C}$			SN74LV14A - 40°C to 85°C		SN74LV14A - 40°C to 125°C		UNIT
				MIN	TYP	MAX	MIN	MAX	MIN	MAX	
t_{pd}	A	Y	$C_L = 15\text{ pF}$	10.2 ⁽¹⁾	19.7 ⁽¹⁾	1	22	1	23	ns	
			$C_L = 50\text{ pF}$	13.3	24	1	27	1	28		

(1) On products compliant to MIL-PRF-38535, this parameter is not production tested.

6.7 Switching Characteristics, $V_{CC} = 3.3\text{ V} \pm 0.3\text{ V}$

over recommended operating free-air temperature range (unless otherwise noted) (see 图 7-1)

PARAMETER	FROM (INPUT)	TO (OUTPUT)	LOAD CAPACITANCE	$T_A = 25^\circ\text{C}$			SN74LV14A - 40°C to 85°C		SN74LV14A - 40°C to 125°C		UNIT
				MIN	TYP	MAX	MIN	MAX	MIN	MAX	
t_{pd}	A	Y	$C_L = 15\text{ pF}$	7.3 ⁽¹⁾	12.8 ⁽¹⁾	1	15	1	16	ns	
			$C_L = 50\text{ pF}$	9.6	16.3	1	18.5	1	19.5		

(1) On products compliant to MIL-PRF-38535, this parameter is not production tested.

6.8 Switching Characteristics, $V_{CC} = 5\text{ V} \pm 0.5\text{ V}$

over recommended operating free-air temperature range (unless otherwise noted) (see 图 7-1)

PARAMETER	FROM (INPUT)	TO (OUTPUT)	LOAD CAPACITANCE	$T_A = 25^\circ\text{C}$			SN74LV14A - 40°C to 85°C		SN74LV14A - 40°C to 125°C		UNIT
				MIN	TYP	MAX	MIN	MAX	MIN	MAX	
t_{pd}	A	Y	$C_L = 15\text{ pF}$	5.1 ⁽¹⁾	8.6 ⁽¹⁾	1	10	1	11	ns	
			$C_L = 50\text{ pF}$	6.7	10.6	1	12	1	13		

(1) On products compliant to MIL-PRF-38535, this parameter is not production tested.

6.9 Noise Characteristics

$V_{CC} = 3.3\text{ V}$, $C_L = 50\text{ pF}$, $T_A = 25^\circ\text{C}$ ⁽¹⁾

		SN74LV14A			UNIT
		MIN	TYP	MAX	
$V_{OL(P)}$	Quiet output, maximum dynamic	0.2	0.8	V	
$V_{OL(V)}$	Quiet output, minimum dynamic	- 0.1	- 0.8	V	
$V_{OH(V)}$	Quiet output, minimum dynamic	3.1		V	
$V_{IH(D)}$	High-level dynamic input voltage	2.31		V	
$V_{IL(D)}$	Low-level dynamic input voltage		0.99	V	

(1) Characteristics are for surface-mount packages only.

6.10 Operating Characteristics

$T_A = 25^\circ\text{C}$

PARAMETER		TEST CONDITIONS	V_{CC}	TYP	UNIT
C_{pd}	Power dissipation capacitance	$C_L = 50\text{ pF}$ $f = 10\text{ MHz}$	3.3 V	8.8	pF
			5 V	9.6	

6.11 Typical Characteristics



图 6-1. TPD vs V_{CC}



图 6-2. TPD vs Temperature

7 Parameter Measurement Information

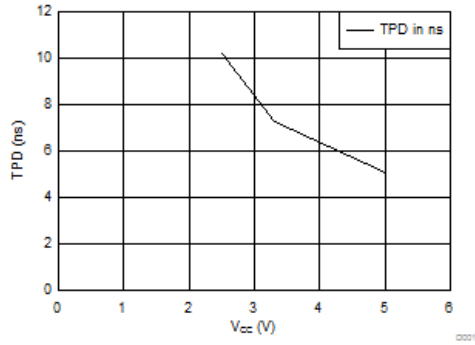
7.1

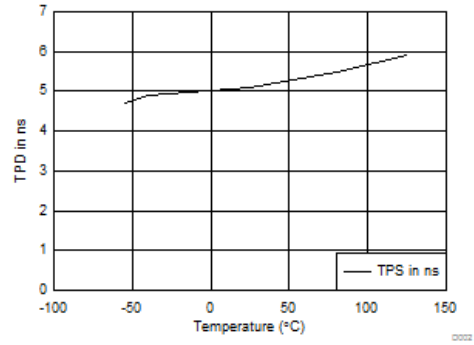
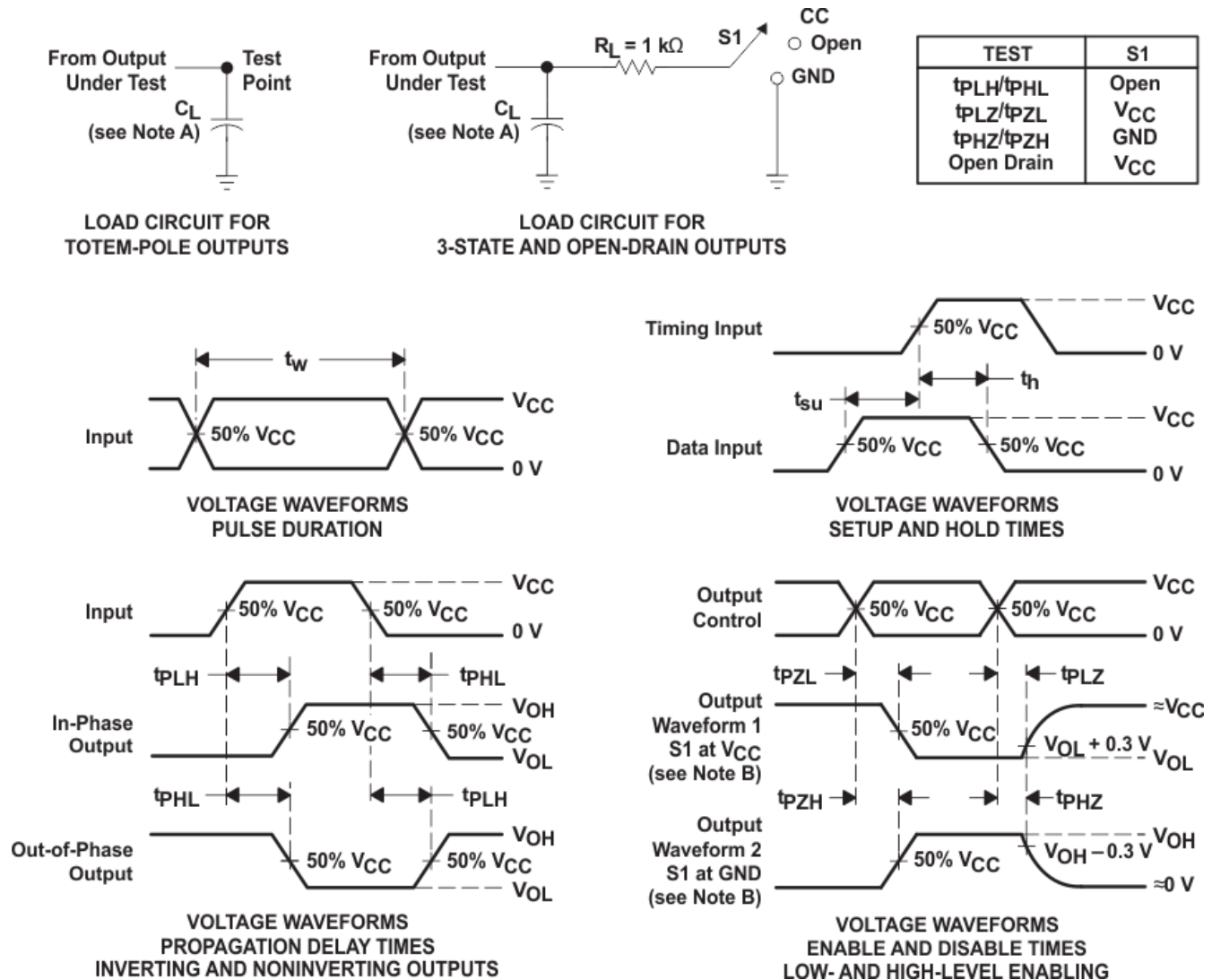

- A. C_L includes probe and jig capacitance.
- B. Waveform 1 is for an output with internal conditions such that the output is low, except when disabled by the output control. Waveform 2 is for an output with internal conditions such that the output is high, except when disabled by the output control.
- C. All input pulses are supplied by generators having the following characteristics: $PRR \leq 1\text{ MHz}$, $Z_O = 50\ \Omega$, $t_r \leq 3\text{ ns}$, $t_f \leq 3\text{ ns}$.
- D. The outputs are measured one at a time, with one input transition per measurement.
- E. t_{PLZ} and t_{PHZ} are the same as t_{dis} .
- F. t_{PZL} and t_{PZH} are the same as t_{en} .
- G. t_{PHL} and t_{PLH} are the same as t_{pd} .
- H. All parameters and waveforms are not applicable to all devices.

图 7-1. Load Circuit and Voltage Waveforms

8 Detailed Description

8.1 Overview

These hex Schmitt-trigger inverters are designed for 2 V to 5.5 V V_{CC} operation.

The SN74LV14A devices contain six independent inverters. These devices perform the Boolean function $Y = \bar{A}$.

These devices are fully specified for partial-power-down application using I_{off} . The I_{off} circuitry disables the outputs, preventing damaging current backflow through the devices when they are powered down.

8.2 Functional Block Diagram



图 8-1. Logic Diagram, Each Inverter (Positive Logic)

8.3 Feature Description

- Wide operating voltage range
 - Operates From 2 V to 5.5 V
- Allows up or down voltage translation
 - Inputs and outputs accept voltages to 5.5 V
- I_{off} feature
 - Allows voltages on the inputs and outputs when V_{CC} is 0 V
- Schmitt-trigger inputs allow for slow or noisy inputs

8.4 Device Functional Modes

表 8-1. Function Table
(Each Inverter)

INPUT ⁽¹⁾ A	OUTPUT ⁽²⁾ Y
H	L
L	H

(1) H = High Voltage Level, L = Low Voltage Level, X = Don't Care

(2) H = Driving High, L = Driving Low, Z = High Impedance State

9 Application and Implementation

备注

以下应用部分中的信息不属于 TI 器件规格的范围，TI 不担保其准确性和完整性。TI 的客户应负责确定器件是否适用于其应用。客户应验证并测试其设计，以确保系统功能。

9.1 Application Information

Schmitt triggers should be used anytime you need to translate a sign wave into a square wave as shown in 图 9-1. They may also be used where a slow or noisy input needs to be sped up or cleaned up as shown in 图 9-2.

9.2 Typical Application



图 9-1. Oscillator Application Schematic



图 9-2. Switch De-bouncer Schematic

9.2.1 Design Requirements

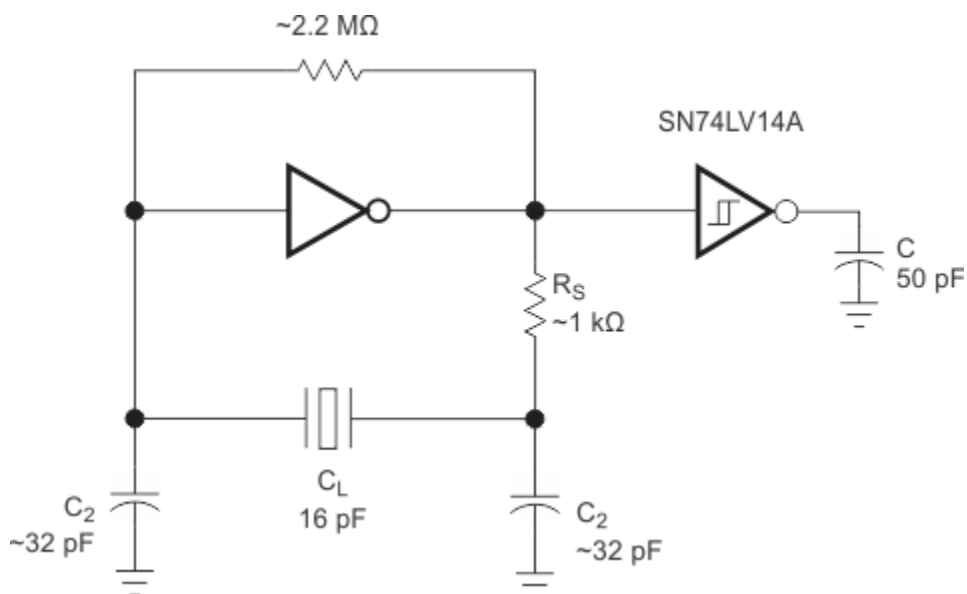
This device uses CMOS technology and has balanced output drive. Care should be taken to avoid bus contention because it can drive currents that would exceed maximum limits. The high drive will also create fast edges into light loads so routing and load conditions should be considered to prevent ringing.

9.2.2 Detailed Design Procedure

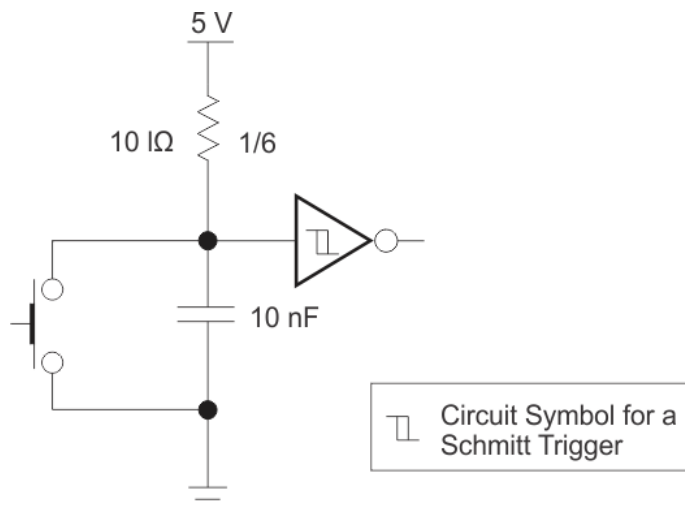
1. Recommended Input Conditions:

- For rise time and fall time specifications, see $\Delta t / \Delta V$ in [§ 6.3](#) table.
- For specified high and low levels, see V_{IH} and V_{IL} in [§ 6.3](#) table.
- Inputs and outputs are overvoltage tolerant allowing them to go as high as 5.5 V at any valid V_{CC} .

2. Recommend Output Conditions:

- Load currents should not exceed 35 mA per output and 50 mA total for the part.

9.2.3 Application Curves



图 9-3. Schmitt Trigger Curves

10 Power Supply Recommendations

The power supply can be any voltage between the MIN and MAX supply voltage rating located in the [# 6.3](#) table.

Each V_{CC} terminal should have a good bypass capacitor to prevent power disturbance. For devices with a single supply, a $0.1 \mu\text{F}$ capacitor is recommended. If there are multiple V_{CC} terminals then $0.01 \mu\text{F}$ or $0.022 \mu\text{F}$ capacitors are recommended for each power terminal. It is ok to parallel multiple bypass capacitors to reject different frequencies of noise. $0.1 \mu\text{F}$ and $1.0 \mu\text{F}$ capacitors are commonly used in parallel. The bypass capacitor should be installed as close to the power terminal as possible for the best results.

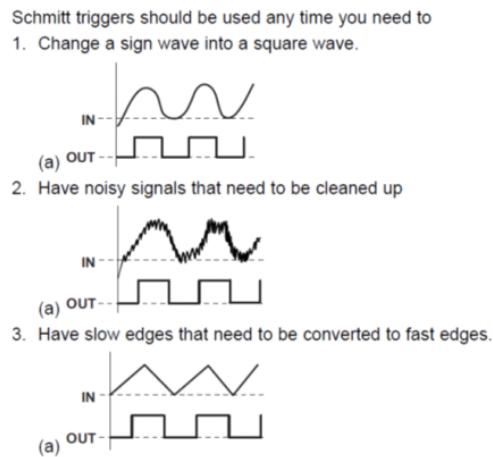
11 Layout

11.1 Layout Guidelines

When using multiple bit logic devices, inputs should not float. In many cases, functions or parts of functions of digital logic devices are unused. Some examples are when only two inputs of a triple-input AND gate are used, or when only 3 of the 4-buffer gates are used. Such input pins should not be left unconnected because the undefined voltages at the outside connections result in undefined operational states. Specified in the [图 11-1](#) are rules that must be observed under all circumstances. All unused inputs of digital logic devices must be connected to a high or low bias to prevent them from floating. The logic level that should be applied to any particular unused input depends on the function of the device. Generally they will be tied to GND or V_{CC} , whichever makes more sense or is more convenient. It is acceptable to float outputs unless the part is a transceiver.

11.2 Layout Example



图 11-1. Layout Diagram

12 Device and Documentation Support

12.1 Related Links

The table below lists quick access links. Categories include technical documents, support and community resources, tools and software, and quick access to sample or buy.

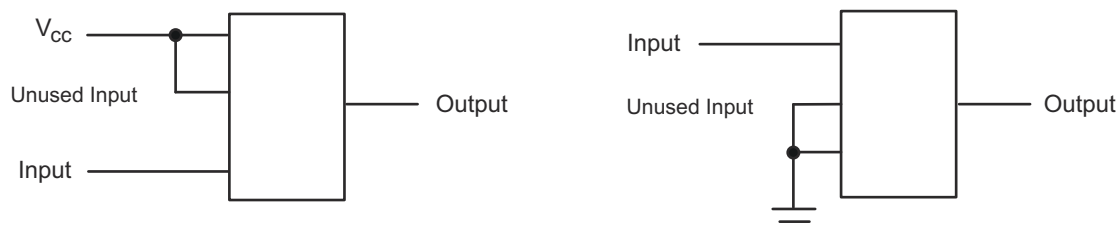
表 12-1. Related Links

PARTS	PRODUCT FOLDER	SAMPLE & BUY	TECHNICAL DOCUMENTS	TOOLS & SOFTWARE	SUPPORT & COMMUNITY
SN54LV14A	Click here	Click here	Click here	Click here	Click here
SN74LV14A	Click here	Click here	Click here	Click here	Click here

12.2 接收文档更新通知

要接收文档更新通知，请导航至 ti.com 上的器件产品文件夹。点击 [订阅更新](#) 进行注册，即可每周接收产品信息更改摘要。有关更改的详细信息，请查看任何已修订文档中包含的修订历史记录。

12.3 支持资源

[TI E2E™ 支持论坛](#) 是工程师的重要参考资料，可直接从专家获得快速、经过验证的解答和设计帮助。搜索现有解答或提出自己的问题可获得所需的快速设计帮助。

链接的内容由各个贡献者“按原样”提供。这些内容并不构成 TI 技术规范，并且不一定反映 TI 的观点；请参阅 TI 的《[使用条款](#)》。

12.4 Trademarks

TI E2E™ is a trademark of Texas Instruments.

所有商标均为其各自所有者的财产。

12.5 Electrostatic Discharge Caution



This integrated circuit can be damaged by ESD. Texas Instruments recommends that all integrated circuits be handled with appropriate precautions. Failure to observe proper handling and installation procedures can cause damage.

ESD damage can range from subtle performance degradation to complete device failure. Precision integrated circuits may be more susceptible to damage because very small parametric changes could cause the device not to meet its published specifications.

12.6 术语表

[TI 术语表](#) 本术语表列出并解释了术语、首字母缩略词和定义。

13 Mechanical, Packaging, and Orderable Information

The following pages include mechanical, packaging, and orderable information. This information is the most current data available for the designated devices. This data is subject to change without notice and revision of this document. For browser-based versions of this data sheet, refer to the left-hand navigation.

PACKAGING INFORMATION

Orderable Device	Status (1)	Package Type	Package Drawing	Pins	Package Qty	Eco Plan (2)	Lead finish/ Ball material (6)	MSL Peak Temp (3)	Op Temp (°C)	Device Marking (4/5)	Samples
SN74LV14AD	ACTIVE	SOIC	D	14	50	RoHS & Green	NIPDAU	Level-1-260C-UNLIM	-40 to 125	LV14A	Samples
SN74LV14ADBR	ACTIVE	SSOP	DB	14	2000	RoHS & Green	NIPDAU	Level-1-260C-UNLIM	-40 to 125	LV14A	Samples
SN74LV14ADGVR	ACTIVE	TVSOP	DGV	14	2000	RoHS & Green	NIPDAU	Level-1-260C-UNLIM	-40 to 125	LV14A	Samples
SN74LV14ADR	ACTIVE	SOIC	D	14	2500	RoHS & Green	NIPDAU SN	Level-1-260C-UNLIM	-40 to 125	LV14A	Samples
SN74LV14ADRG4	ACTIVE	SOIC	D	14	2500	RoHS & Green	NIPDAU	Level-1-260C-UNLIM	-40 to 125	LV14A	Samples
SN74LV14ANSR	ACTIVE	SO	NS	14	2000	RoHS & Green	NIPDAU	Level-1-260C-UNLIM	-40 to 125	74LV14A	Samples
SN74LV14APW	ACTIVE	TSSOP	PW	14	90	RoHS & Green	NIPDAU	Level-1-260C-UNLIM	-40 to 125	LV14A	Samples
SN74LV14APWG4	ACTIVE	TSSOP	PW	14	90	RoHS & Green	NIPDAU	Level-1-260C-UNLIM	-40 to 125	LV14A	Samples
SN74LV14APWR	ACTIVE	TSSOP	PW	14	2000	RoHS & Green	NIPDAU SN	Level-1-260C-UNLIM	-40 to 125	LV14A	Samples
SN74LV14APWRG3	ACTIVE	TSSOP	PW	14	2000	RoHS & Green	SN	Level-1-260C-UNLIM	-40 to 125	LV14A	Samples
SN74LV14APWRG4	ACTIVE	TSSOP	PW	14	2000	RoHS & Green	NIPDAU	Level-1-260C-UNLIM	-40 to 125	LV14A	Samples
SN74LV14APWT	ACTIVE	TSSOP	PW	14	250	RoHS & Green	NIPDAU	Level-1-260C-UNLIM	-40 to 125	LV14A	Samples
SN74LV14ARGYR	ACTIVE	VQFN	RGY	14	3000	RoHS & Green	NIPDAU	Level-2-260C-1 YEAR	-40 to 125	LV14A	Samples

(1) The marketing status values are defined as follows:

ACTIVE: Product device recommended for new designs.

LIFEBUY: TI has announced that the device will be discontinued, and a lifetime-buy period is in effect.

NRND: Not recommended for new designs. Device is in production to support existing customers, but TI does not recommend using this part in a new design.

PREVIEW: Device has been announced but is not in production. Samples may or may not be available.

OBSELETE: TI has discontinued the production of the device.

(2) **RoHS:** TI defines "RoHS" to mean semiconductor products that are compliant with the current EU RoHS requirements for all 10 RoHS substances, including the requirement that RoHS substance do not exceed 0.1% by weight in homogeneous materials. Where designed to be soldered at high temperatures, "RoHS" products are suitable for use in specified lead-free processes. TI may reference these types of products as "Pb-Free".

RoHS Exempt: TI defines "RoHS Exempt" to mean products that contain lead but are compliant with EU RoHS pursuant to a specific EU RoHS exemption.

Green: TI defines "Green" to mean the content of Chlorine (Cl) and Bromine (Br) based flame retardants meet JS709B low halogen requirements of <=1000ppm threshold. Antimony trioxide based flame retardants must also meet the <=1000ppm threshold requirement.

(3) MSL, Peak Temp. - The Moisture Sensitivity Level rating according to the JEDEC industry standard classifications, and peak solder temperature.

(4) There may be additional marking, which relates to the logo, the lot trace code information, or the environmental category on the device.

(5) Multiple Device Markings will be inside parentheses. Only one Device Marking contained in parentheses and separated by a "~" will appear on a device. If a line is indented then it is a continuation of the previous line and the two combined represent the entire Device Marking for that device.

(6) Lead finish/Ball material - Orderable Devices may have multiple material finish options. Finish options are separated by a vertical ruled line. Lead finish/Ball material values may wrap to two lines if the finish value exceeds the maximum column width.

Important Information and Disclaimer:The information provided on this page represents TI's knowledge and belief as of the date that it is provided. TI bases its knowledge and belief on information provided by third parties, and makes no representation or warranty as to the accuracy of such information. Efforts are underway to better integrate information from third parties. TI has taken and continues to take reasonable steps to provide representative and accurate information but may not have conducted destructive testing or chemical analysis on incoming materials and chemicals. TI and TI suppliers consider certain information to be proprietary, and thus CAS numbers and other limited information may not be available for release.

In no event shall TI's liability arising out of such information exceed the total purchase price of the TI part(s) at issue in this document sold by TI to Customer on an annual basis.

OTHER QUALIFIED VERSIONS OF SN74LV14A :

- Automotive : [SN74LV14A-Q1](#)
- Enhanced Product : [SN74LV14A-EP](#)

NOTE: Qualified Version Definitions:

- Automotive - Q100 devices qualified for high-reliability automotive applications targeting zero defects
- Enhanced Product - Supports Defense, Aerospace and Medical Applications

TAPE AND REEL INFORMATION

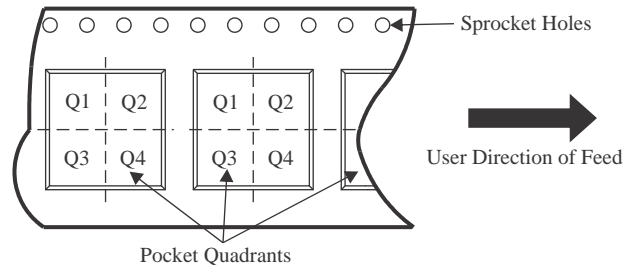
QUADRANT ASSIGNMENTS FOR PIN 1 ORIENTATION IN TAPE

*All dimensions are nominal

Device	Package Type	Package Drawing	Pins	SPQ	Reel Diameter (mm)	Reel Width W1 (mm)	A0 (mm)	B0 (mm)	K0 (mm)	P1 (mm)	W (mm)	Pin1 Quadrant
SN74LV14ADBR	SSOP	DB	14	2000	330.0	16.4	8.35	6.6	2.4	12.0	16.0	Q1
SN74LV14ADGVR	TVSOP	DGV	14	2000	330.0	12.4	6.8	4.0	1.6	8.0	12.0	Q1
SN74LV14ADR	SOIC	D	14	2500	330.0	16.4	6.5	9.0	2.1	8.0	16.0	Q1
SN74LV14ADR	SOIC	D	14	2500	330.0	16.8	6.5	9.5	2.1	8.0	16.0	Q1
SN74LV14ADR	SOIC	D	14	2500	330.0	16.4	6.5	9.0	2.1	8.0	16.0	Q1
SN74LV14ADRG4	SOIC	D	14	2500	330.0	16.4	6.5	9.0	2.1	8.0	16.0	Q1
SN74LV14ADRG4	SOIC	D	14	2500	330.0	16.4	6.5	9.0	2.1	8.0	16.0	Q1
SN74LV14ANSR	SO	NS	14	2000	330.0	16.4	8.45	10.55	2.5	12.0	16.2	Q1
SN74LV14APWR	TSSOP	PW	14	2000	330.0	12.4	6.9	5.6	1.6	8.0	12.0	Q1
SN74LV14APWR	TSSOP	PW	14	2000	330.0	12.4	6.9	5.6	1.6	8.0	12.0	Q1
SN74LV14APWRG3	TSSOP	PW	14	2000	330.0	12.4	6.9	5.6	1.6	8.0	12.0	Q1
SN74LV14APWRG4	TSSOP	PW	14	2000	330.0	12.4	6.9	5.6	1.6	8.0	12.0	Q1
SN74LV14APWT	TSSOP	PW	14	250	330.0	12.4	6.9	5.6	1.6	8.0	12.0	Q1
SN74LV14ARGYR	VQFN	RGY	14	3000	330.0	12.4	3.75	3.75	1.15	8.0	12.0	Q1

TAPE AND REEL BOX DIMENSIONS

*All dimensions are nominal

Device	Package Type	Package Drawing	Pins	SPQ	Length (mm)	Width (mm)	Height (mm)
SN74LV14ADBR	SSOP	DB	14	2000	356.0	356.0	35.0
SN74LV14ADGVR	TVSOP	DGV	14	2000	356.0	356.0	35.0
SN74LV14ADR	SOIC	D	14	2500	356.0	356.0	35.0
SN74LV14ADR	SOIC	D	14	2500	364.0	364.0	27.0
SN74LV14ADR	SOIC	D	14	2500	340.5	336.1	32.0
SN74LV14ADRG4	SOIC	D	14	2500	340.5	336.1	32.0
SN74LV14ADRG4	SOIC	D	14	2500	356.0	356.0	35.0
SN74LV14ANSR	SO	NS	14	2000	367.0	367.0	38.0
SN74LV14APWR	TSSOP	PW	14	2000	364.0	364.0	27.0
SN74LV14APWR	TSSOP	PW	14	2000	356.0	356.0	35.0
SN74LV14APWRG3	TSSOP	PW	14	2000	364.0	364.0	27.0
SN74LV14APWRG4	TSSOP	PW	14	2000	356.0	356.0	35.0
SN74LV14APWT	TSSOP	PW	14	250	356.0	356.0	35.0
SN74LV14ARGYR	VQFN	RGY	14	3000	356.0	356.0	35.0

TUBE

*All dimensions are nominal

Device	Package Name	Package Type	Pins	SPQ	L (mm)	W (mm)	T (μm)	B (mm)
SN74LV14AD	D	SOIC	14	50	507	8	3940	4.32
SN74LV14AD	D	SOIC	14	50	506.6	8	3940	4.32
SN74LV14APW	PW	TSSOP	14	90	530	10.2	3600	3.5
SN74LV14APWG4	PW	TSSOP	14	90	530	10.2	3600	3.5

RGY (S-PVQFN-N14)

PLASTIC QUAD FLATPACK NO-LEAD



- NOTES:
- A. All linear dimensions are in millimeters. Dimensioning and tolerancing per ASME Y14.5M-1994.
 - B. This drawing is subject to change without notice.
 - C. QFN (Quad Flatpack No-Lead) package configuration.
 - D. The package thermal pad must be soldered to the board for thermal and mechanical performance.
 - E. See the additional figure in the Product Data Sheet for details regarding the exposed thermal pad features and dimensions.
 -  Pin 1 identifiers are located on both top and bottom of the package and within the zone indicated. The Pin 1 identifiers are either a molded, marked, or metal feature.
 - G. Package complies to JEDEC MO-241 variation BA.

RGY (S-PVQFN-N14)

PLASTIC QUAD FLATPACK NO-LEAD

THERMAL INFORMATION

This package incorporates an exposed thermal pad that is designed to be attached directly to an external heatsink. The thermal pad must be soldered directly to the printed circuit board (PCB). After soldering, the PCB can be used as a heatsink. In addition, through the use of thermal vias, the thermal pad can be attached directly to the appropriate copper plane shown in the electrical schematic for the device, or alternatively, can be attached to a special heatsink structure designed into the PCB. This design optimizes the heat transfer from the integrated circuit (IC).

For information on the Quad Flatpack No-Lead (QFN) package and its advantages, refer to Application Report, QFN/SON PCB Attachment, Texas Instruments Literature No. SLUA271. This document is available at www.ti.com.

The exposed thermal pad dimensions for this package are shown in the following illustration.



Bottom View

Exposed Thermal Pad Dimensions

4206353-2/P 03/14

NOTE: All linear dimensions are in millimeters

RGY (S-PVQFN-N14)

PLASTIC QUAD FLATPACK NO-LEAD



4208122-2/P 03/14

- NOTES:
- All linear dimensions are in millimeters.
 - This drawing is subject to change without notice.
 - Publication IPC-7351 is recommended for alternate designs.
 - This package is designed to be soldered to a thermal pad on the board. Refer to Application Note, Quad Flat-Pack QFN/SON PCB Attachment, Texas Instruments Literature No. SLUA271, and also the Product Data Sheets for specific thermal information, via requirements, and recommended board layout. These documents are available at www.ti.com <<http://www.ti.com>>.
 - Laser cutting apertures with trapezoidal walls and also rounding corners will offer better paste release. Customers should contact their board assembly site for stencil design recommendations. Refer to IPC 7525 for stencil design considerations.
 - Customers should contact their board fabrication site for minimum solder mask web tolerances between signal pads.

MECHANICAL DATA

NS (R-PDSO-G**)

PLASTIC SMALL-OUTLINE PACKAGE

14-PINS SHOWN



4040062/C 03/03

- NOTES:
- A. All linear dimensions are in millimeters.
 - B. This drawing is subject to change without notice.
 - C. Body dimensions do not include mold flash or protrusion, not to exceed 0,15.

DGV (R-PDSO-G**)

PLASTIC SMALL-OUTLINE

24 PINS SHOWN



- NOTES: A. All linear dimensions are in millimeters.
 B. This drawing is subject to change without notice.
 C. Body dimensions do not include mold flash or protrusion, not to exceed 0,15 per side.
 D. Falls within JEDEC: 24/48 Pins – MO-153
 14/16/20/56 Pins – MO-194

D (R-PDSO-G14)

PLASTIC SMALL OUTLINE



- NOTES:
- A. All linear dimensions are in inches (millimeters).
 - B. This drawing is subject to change without notice.
 - Body length does not include mold flash, protrusions, or gate burrs. Mold flash, protrusions, or gate burrs shall not exceed 0.006 (0,15) each side.
 - Body width does not include interlead flash. Interlead flash shall not exceed 0.017 (0,43) each side.
 - E. Reference JEDEC MS-012 variation AB.

D (R-PDSO-G14)

PLASTIC SMALL OUTLINE



4211283-3/E 08/12

- NOTES:
- A. All linear dimensions are in millimeters.
 - B. This drawing is subject to change without notice.
 - C. Publication IPC-7351 is recommended for alternate designs.
 - D. Laser cutting apertures with trapezoidal walls and also rounding corners will offer better paste release. Customers should contact their board assembly site for stencil design recommendations. Refer to IPC-7525 for other stencil recommendations.
 - E. Customers should contact their board fabrication site for solder mask tolerances between and around signal pads.

PW (R-PDSO-G14)

PLASTIC SMALL OUTLINE



- NOTES:
- All linear dimensions are in millimeters.
 - This drawing is subject to change without notice.
 - Publication IPC-7351 is recommended for alternate designs.
 - Laser cutting apertures with trapezoidal walls and also rounding corners will offer better paste release. Customers should contact their board assembly site for stencil design recommendations. Refer to IPC-7525 for other stencil recommendations.
 - Customers should contact their board fabrication site for solder mask tolerances between and around signal pads.

DB (R-PDSO-G**)

PLASTIC SMALL-OUTLINE

28 PINS SHOWN



- NOTES: A. All linear dimensions are in millimeters.
 B. This drawing is subject to change without notice.
 C. Body dimensions do not include mold flash or protrusion not to exceed 0,15.
 D. Falls within JEDEC MO-150

重要声明和免责声明

TI“按原样”提供技术和可靠性数据（包括数据表）、设计资源（包括参考设计）、应用或其他设计建议、网络工具、安全信息和其他资源，不保证没有瑕疵且不做任何明示或暗示的担保，包括但不限于对适销性、某特定用途方面的适用性或不侵犯任何第三方知识产权的暗示担保。

这些资源可供使用 TI 产品进行设计的熟练开发人员使用。您将自行承担以下全部责任：(1) 针对您的应用选择合适的 TI 产品，(2) 设计、验证并测试您的应用，(3) 确保您的应用满足相应标准以及任何其他功能安全、信息安全、监管或其他要求。

这些资源如有变更，恕不另行通知。TI 授权您仅可将这些资源用于研发本资源所述的 TI 产品的应用。严禁对这些资源进行其他复制或展示。您无权使用任何其他 TI 知识产权或任何第三方知识产权。您应全额赔偿因在这些资源的使用中对 TI 及其代表造成的任何索赔、损害、成本、损失和债务，TI 对此概不负责。

TI 提供的产品受 [TI 的销售条款](#) 或 [ti.com](#) 上其他适用条款/TI 产品随附的其他适用条款的约束。TI 提供这些资源并不会扩展或以其他方式更改 TI 针对 TI 产品发布的适用的担保或担保免责声明。

TI 反对并拒绝您可能提出的任何其他或不同的条款。

邮寄地址：Texas Instruments, Post Office Box 655303, Dallas, Texas 75265

Copyright © 2022，德州仪器 (TI) 公司

X-ON Electronics

Largest Supplier of Electrical and Electronic Components

Click to view similar products for [Inverters](#) category:

Click to view products by [Texas Instruments](#) manufacturer:

Other Similar products are found below :

[E5-652Z](#) [NLX2G04BMX1TCG](#) [CD4009UBE](#) [TC4584BFN](#) [NL17SG14AMUTCG](#) [NLU2GU04BMX1TCG](#) [NLV17SZ14DFT2G](#)
[NLV74HC04ADTR2G](#) [NLU1G04AMUTCG](#) [NLX2G04CMUTCG](#) [NLX2G04AMUTCG](#) [NLV27WZ04DFT1G](#) [NLU1G04CMUTCG](#)
[NL17SZU04P5T5G](#) [74LVC06ADTR2G](#) [74LVC04ADR2G](#) [NLV37WZ04USG](#) [NLX3G14FMUTCG](#) [NL17SZ04P5T5G](#) [NL17SG14P5T5G](#)
[NLV27WZU04DFT2G](#) [NLV17SG14DFT2G](#) [NLVHC1G04DFT2G](#) [MC14069UBD](#) [NLU3G14CMX1TCG](#) [NLX2G14BMX1TCG](#)
[NLX2GU04AMX1TCG](#) [74HCT04DT](#) [74HCT14DT](#) [74LCX14FT\(AJ\)](#) [EG8015](#) [GN14D](#) [GN4069](#) [74HC04DM/TR](#) [HG74HC04M/TR](#)
[CD40106DM/TR](#) [CD4007BE](#) [74HC14DN](#) [74HC14DM/TR](#) [CD4069UBE](#) [74HC125M/TR](#) [CD4069UBMT/TR](#) [HG74HC04MT/TR](#)
[74HC14DMT/TR](#) [74HC04DN](#) [HT74HC04ARZ](#) [HT40106ARZ](#) [74HC14-HXY](#) [IW4069UBN](#) [RS1GT04XC5](#)