

DESCRIPTION

The SN74LV8153 is a serial-to-parallel data converter. It accepts serial input data and outputs 8-bit parallel data.

The automatic data-rate detection feature of the SN74LV8153 eliminates the need for an external oscillator and helps with cost and board real-estate savings.

The OUTSEL pin is used to choose between open collector and push-pull outputs. The open-collector option is suitable when this device is used in applications such as LED interface, where high drive current is required. SOUT is the output that acknowledges reception of the serial data.

To ensure the high-impedance state during power up or power down, \overline{OE} should be tied to V_{CC1} through a pullup resistor; the minimum value of the resistor is determined by the current-sinking capability of the driver.

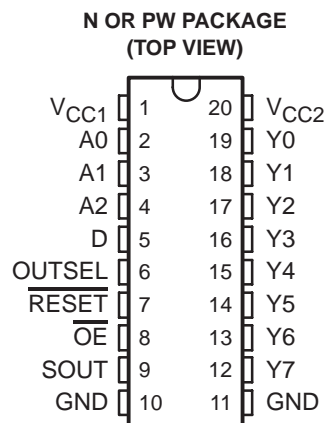

**FUNCTION TABLE
(each buffer)**

INPUTS				OUTPUT Y _n	OUTPUT STRUCTURE
OUTSEL	\overline{RESET}	\overline{OE}	D _n		
L	H	L	H	L	Open collector
L	H	L	L	H	
L	X	H	X	H	
L	L	X	X	H	
H	H	L	H	H	Push-pull
H	H	L	L	L	
H	X	H	X	Z	
H	L	L	X	L	

In the open-collector mode (OUTSEL = L), the outputs are inverted, e.g., Y1 = I, when D1 = H

FEATURES

- Single-Wire Serial Data Input
- Compatible With UART Serial-Data Format
- Up to Eight Devices (64-Bit Parallel) Can Share the Same Bus by Using Different Combinations of A0, A1, A2
- Up to 40 mA Current Drive in Open-Collector Mode for Driving LEDs
- Outputs Can be Configured as Open-Collector or Push-Pull
- Internal Oscillator and Counter for Automatic Data-Rate Detection
- Output Levels Are Referenced to V_{CC2} and Can Be Configured From 3 V to 12 V
- Latch-Up Performance Exceeds 250 mA Per JESD 17
- ESD Protection Exceeds JESD 22
 - 2000-V Human-Body Model (A114-A)
 - 1000-V Charged-Device Model (C101)

SUMMARY OF RECOMMENDED OPERATING CONDITIONS

PARAMETER	
V_{CC1}	3 V to 5.5 V
V_{CC2}	3 V to 13.2 V
I_{OL}	40 mA @ $V_{CC2} = 4.5$ V (open-collector mode)
I_{OH}	–24 mA @ $V_{CC2} = 12$ V (push-pull mode)
Maximum Data Rate	24 Kbps



Please be aware that an important notice concerning availability, standard warranty, and use in critical applications of Texas Instruments semiconductor products and disclaimers thereto appears at the end of this data sheet.

ORDERING INFORMATION

T_A	PACKAGE(1)		ORDERABLE PART NUMBER	TOP-SIDE MARKING
-40°C to 85°C	PDIP – N	Tube	SN74LV8153N	SN74LV8153N
	TSSOP – PW	Tube	SN74LV8153PW	LV8153
		Tape and reel	SN74LV8153PWR	

(1) Package drawings, standard packing quantities, thermal data, symbolization, and PCB design guidelines are available at www.ti.com/sc/package.

PIN DESCRIPTION

PIN #	PIN NAME	I/O	PIN FUNCTION
1	V _{CC1}		Power-supply pin (all inputs and outputs except for Y0-Y7)
2-4	A0, A1, A2	In	The address pins are used to program the address of the device and allow up to eight devices to share the same bus.
5	D	In	Serial data input
6	OUTSEL	In	Choose between open-collector and push-pull type outputs (Y0-Y7).
7	$\overline{\text{RESET}}$	In	Initialize register status
8	$\overline{\text{OE}}$	In	Force Y0-Y7 to Hi-Z
9	SOUT	Out	Outputs a pulse when latch data is changed. Supplied by V _{CC1} .
12-19	Y0-Y7	Out	Push-pull or open collector parallel data outputs. Supplied by V _{CC2} .
20	V _{CC2}		Power-supply pin for outputs (Y0-Y7). V _{CC2} can range from 3 V to 13.2 V.

data transmission protocol

- The serial data should be sent as 2START-3ADDRESS-4DATA-1STOP. Two consecutive serial-data frames transmit 8 bits of data. The first frame includes the lower four bits of data (D0-D3), and the second frame includes the upper four bits (D4-D7).
- The three address bits (in the consecutive frame) must be the same as those in the first frame; otherwise, the data will be dropped.
- The order of the two start bits must be 0, then 1 in any frame; otherwise, the data rate will not be detected correctly. The period between the falling edge of the first start bit (ST0) and the rising edge of the second start bit (ST1) is measured to generate an internal-clock synchronized data stream.

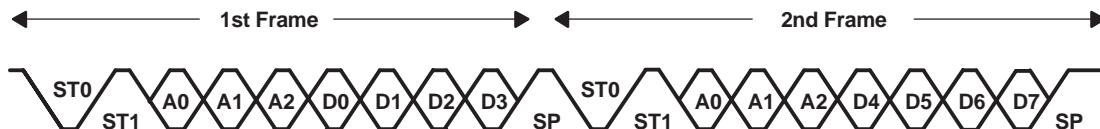

Example of Serial-Data Format

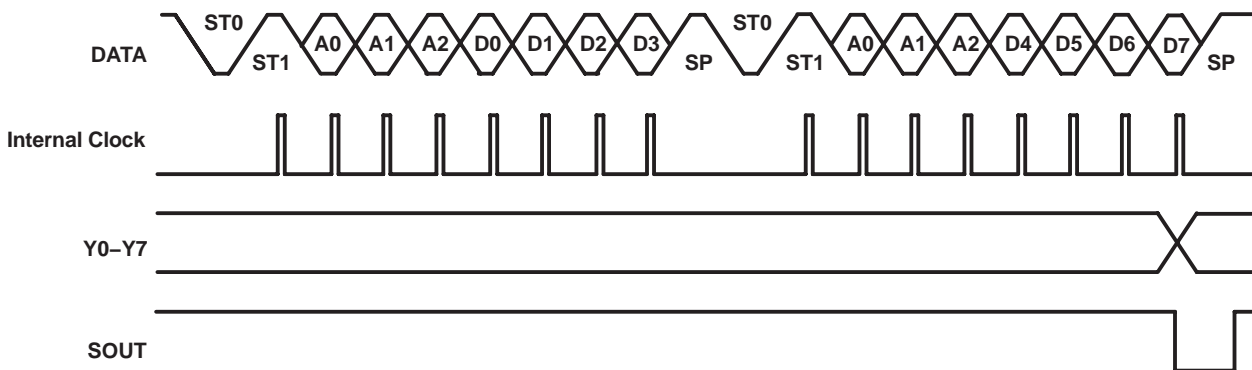

Timing Chart

(1) Internal clock cannot be observed.

(2) D0 is LSB and D7 is MSB. The data stream should be LSB first.

logic diagram

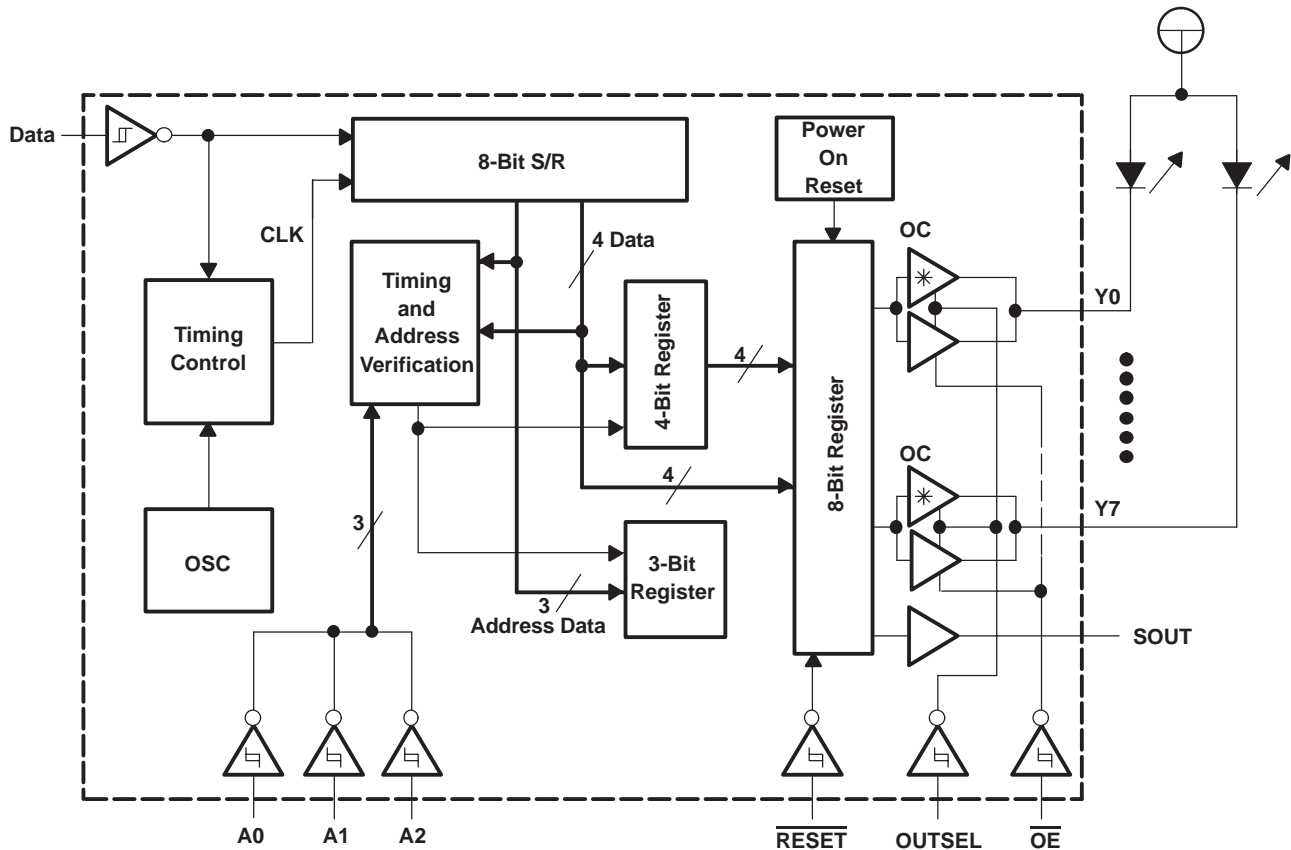

absolute maximum ratings over operating free-air temperature range (unless otherwise noted)⁽¹⁾

Supply voltage range, V_{CC1}	-0.5 V to 7 V
Supply voltage range, V_{CC2}	-0.5 V to 14.5 V
Input voltage range, V_I ⁽²⁾	-0.5 V to 7 V
Voltage range applied to any output in the high or low state, V_O (SOUT) ⁽²⁾⁽³⁾	-0.5 V to $V_{CC1} + 0.5$ V
Voltage range applied to any output in the high-impedance or power-off state, V_O (SOUT) ⁽²⁾	-0.5 V to 7 V
Voltage range, applied to any output in the high or low state, V_O (Y0-Y7) ⁽²⁾⁽³⁾	-0.5 V to $V_{CC2} + 0.5$ V
Voltage range applied to any output in the high-impedance or power-off state, V_O (Y0-Y7) ⁽²⁾	-0.5 V to 14.5 V
Input clamp current, I_{IK} ($V_I < 0$)	-20 mA
Output clamp current, I_{OK} ($V_O < 0$)	-50 mA
Continuous output current, I_O ($V_O = 0$ to V_{CC})	25 mA
Continuous current, I_O (OUTSEL = L, Y0-Y7 = L)	60 mA
Package thermal impedance, θ_{JA} ⁽⁴⁾ : N package	69°C/W
..... PW package	83°C/W
Storage temperature range, T_{stg}	-65°C to 150°C

(1) Stresses beyond those listed under "absolute maximum ratings" may cause permanent damage to the device. These are stress ratings only, and functional operation of the device at these or any other conditions beyond those indicated under "recommended operating conditions" is not implied. Exposure to absolute-maximum-rated conditions for extended periods may affect device reliability.

(1)The input and output voltage ratings may be exceeded if the input and output current ratings are observed.

(2)The value of V_{CC} is provided in the recommended operating condition table.

(3)The package thermal impedance is calculated in accordance with JESD 51-7.

recommended operating conditions⁽¹⁾

			V _{CC1}	V _{CC2}	MIN	MAX	UNIT	
V _{CC1}	Supply voltage				3	5.5	V	
V _{CC2}	Supply voltage				3	13.2	V	
V _{IH}	High-level input voltage		3 V	3 V	V _{CC} × 0.7		V	
			4.5 V	4.5 V	V _{CC} × 0.7			
V _{IL}	Low-level input voltage		3 V	3 V	V _{CC} × 0.3		V	
			4.5 V	4.5 V	V _{CC} × 0.3			
V _I	Input voltage				0	5.5	V	
V _O	Output voltage		4.5 V	4.5 V	0	5.5	V	
				12 V	0	13.2		
I _{OH}	High-level output current	Y _n	OUTSEL = H		3 V	3 V	-2	mA
					4.5 V	4.5 V	-8	
					4.5 V	12 V	-24	
		SOUT		3 V	3 V	-4	mA	
				4.5 V	4.5 V	-8		
I _{OL}	Low-level output current	Y _n	OUTSEL = H		3 V	3 V	2	mA
					4.5 V	4.5 V	8	
			OUTSEL = L		3 V	3 V	20	
					4.5 V	4.5 V	40	
		SOUT		3 V	3 V	4		
				4.5 V	4.5 V	8		
T _A	Operating free-air temperature				-40	85	°C	

⁽¹⁾ All unused inputs of the device must be held at V_{CC} or GND to ensure proper device operation. Refer to the TI application report, *Implications of Slow or Floating CMOS Inputs*, literature number SCBA004.

electrical characteristics over recommended operating free-air temperature range (unless otherwise noted)

PARAMETER	TEST CONDITIONS		VCC1	VCC2	MIN	TYP	MAX	UNIT
V_{T+} Positive-going input threshold voltage	All inputs		3.3 V	3.3 V			2.31	V
			5 V	5 V			3.5	
V_{T-} Negative-going input threshold voltage	All inputs		3.3 V	3.3 V	0.99			V
			5 V	5 V	1.5			
ΔV_T Hysteresis ($V_{T+} - V_{T-}$)	All inputs		3.3 V	3.3 V	0.33		1.32	V
			5 V	5 V	0.5		2	
V_{OH}	Yn	$I_{OH} = -2$ mA	3 V	3 V	2.38			V
		$I_{OH} = -8$ mA	4.5 V	4.5 V	3.8			
		$I_{OH} = -24$ mA	4.5 V	12 V	11			
	SOUT	$I_{OH} = -4$ mA	3 V	3 V	2.38			
		$I_{OH} = -8$ mA	4.5 V	4.5 V	3.8			
V_{OL}	Yn	$I_{OL} = 2$ mA (OUTSEL = H)	3 V	3 V			0.44	V
		$I_{OL} = 8$ mA (OUTSEL = H)	4.5 V	4.5 V			0.44	
		$I_{OL} = 40$ mA (OUTSEL = L)	4.5 V	4.5 V			0.5	
	SOUT	$I_{OL} = 4$ mA	3 V	3 V			0.44	
		$I_{OL} = 8$ mA	4.5 V	4.5 V			0.44	
I_I	$V_I = 5.5$ V or GND		0 to 5.5 V				± 1	μ A
I_{OZ}	$V_O = V_{CC}$ or GND (OUTSEL = H)		5.5 V	5.5 V			± 5	μ A
I_{OH}	$V_O = 12$ V (OUTSEL = L)		5.5 V	5.5 V			5	μ A
I_{CC}	$V_I = V_{CC}$ or GND, $I_O = 0$	OUTSEL = H	5.5 V	5.5 V			5	mA
		OUTSEL = L					20	
I_{off} (except SOUT)	V_I or $V_O = 0$ to 5.5 V, $V_{CC} = 0$		0	0			± 50	μ A
C_i	$V_I = V_{CC}$ or GND		5 V	5 V			5	pF

switching characteristics over recommended operating free-air temperature range, $V_{CC1} = V_{CC2} = 3.3$ V \pm 0.3 V (unless otherwise noted) (see Figures 1 and 2)

PARAMETER	FROM (INPUT)	TO (OUTPUT)	LOAD CAPACITANCE	$T_A = 25^\circ\text{C}$			MIN	MAX	UNIT
				MIN	TYP	MAX			
t_{pd}	D7	Y	$C_L = 50$ pF		$P_w/2$	(1)			ns
	D7	SOUT			$P_w/2$	(1)			
	$\overline{\text{RESET}}$	Y						200	
	$\overline{\text{OE}}$ (2)	Y						200	
t_{en}	$\overline{\text{OE}}$ (3)	Y						200	ns
t_{dis}	$\overline{\text{OE}}$ (3)	Y						200	ns
t_w		SOUT			P_w	(4)			ns
Data rate						2	24	Kbps	

(1) The t_{pd} is dependent on the data pulse width (P_w), and Y outputs are changed after one-half of P_w , because the internal clock is synchronized at the middle of the data pulse. Not tested, but specified by design.

(2) When outputs are open collector (OUTSEL = L)

(3) When outputs are push-pull (OUTSEL = H)

(4) SOUT goes low when the data is received correctly and maintains a low level for one data-pulse period. Not tested, but specified by design.

switching characteristics over recommended operating free-air temperature range, $V_{CC1} = V_{CC2} = 5\text{ V} \pm 0.5\text{ V}$ (unless otherwise noted) (see Figures 1 and 2)

PARAMETER	FROM (INPUT)	TO (OUTPUT)	LOAD CAPACITANCE	$T_A = 25^\circ\text{C}$			MIN	MAX	UNIT
				MIN	TYP	MAX			
t_{pd}	D7	Y	$C_L = 50\text{ pF}$		$P_w/2$	(1)			ns
	D7	SOUT			$P_w/2$	(1)			
	$\overline{\text{RESET}}$	Y						150	
	$\overline{\text{OE}}(2)$	Y						150	
t_{en}	$\overline{\text{OE}}(3)$	Y						150	ns
t_{dis}	$\overline{\text{OE}}(3)$	Y						150	ns
t_w		SOUT			P_w	(4)			ns
Data rate							2	24	Kbps

(1) The t_{pd} is dependent on the data pulse width (P_w), and Y outputs are changed after one-half of P_w , because the internal clock is synchronized at the middle of the data pulse. Not tested, but specified by design.

(2) When outputs are open collector (OUTSEL = L)

(3) When outputs are push-pull (OUTSEL = H)

(4) SOUT goes low when the data is received correctly and maintains a low level for one data-pulse period. Not tested, but specified by design.

PARAMETER MEASUREMENT INFORMATION
(PUSH-PULL OUTPUT)

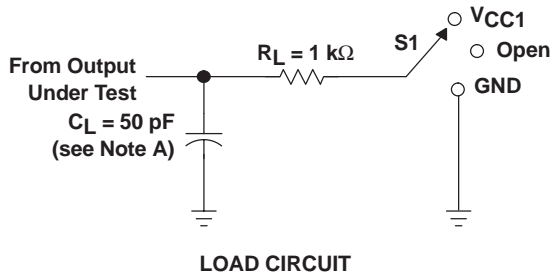

TEST	S1
t_{PLH}/t_{PHL}	Open
t_{PLZ}/t_{PZL}	VCC1
t_{PHZ}/t_{PZH}	GND

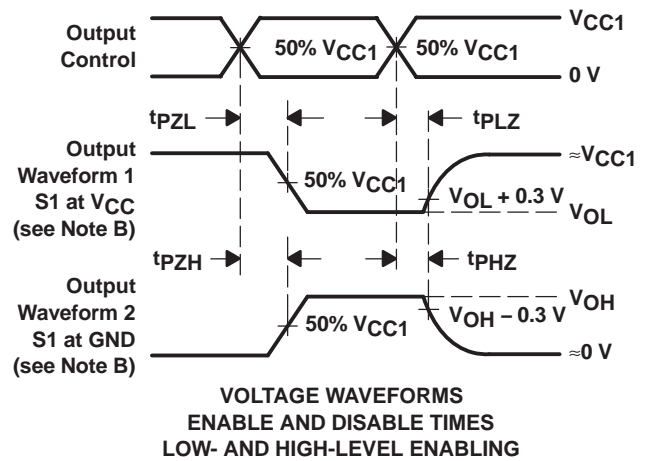
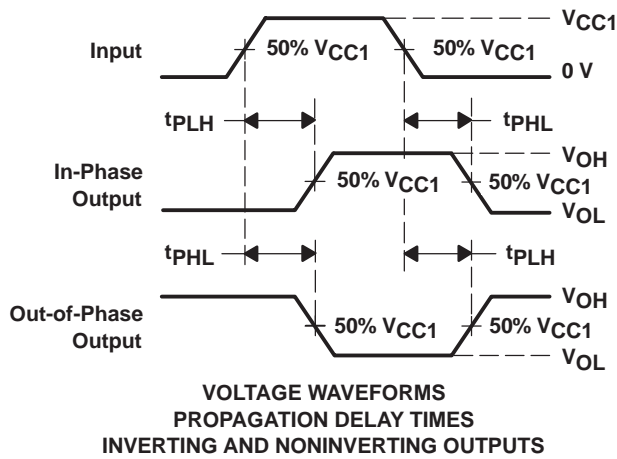

- NOTES:
- A. C_L includes probe and jig capacitance.
 - B. Waveform 1 is for an output with internal conditions such that the output is low, except when disabled by the output control. Waveform 2 is for an output with internal conditions such that the output is high, except when disabled by the output control.
 - C. All input pulses are supplied by generators having the following characteristics: $Z_O = 50 \Omega$, $t_r \leq 3 \text{ ns}$, $t_f \leq 3 \text{ ns}$.
 - D. The outputs are measured one at a time, with one input transition per measurement.
 - E. t_{PLZ} and t_{PHZ} are the same as t_{dis} .
 - F. t_{PZL} and t_{PZH} are the same as t_{en} .
 - G. t_{PHL} and t_{PLH} are the same as t_{pd} .
 - H. All parameters and waveforms are not applicable to all devices.

Figure 1. Load Circuit and Voltage Waveforms

PARAMETER MEASUREMENT INFORMATION
(OPEN-COLLECTOR OUTPUT)

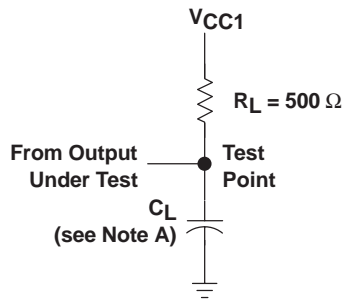

**LOAD CIRCUIT FOR
 OPEN-COLLECTOR OUTPUTS**

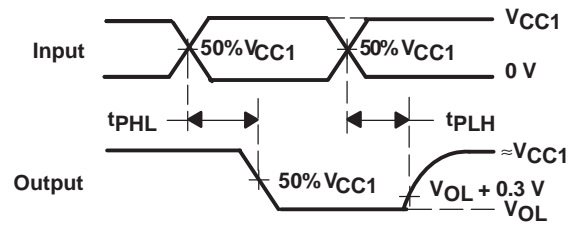

**VOLTAGE WAVEFORMS
 PROPAGATION DELAY TIMES**

- NOTES:
- A. C_L includes probe and jig capacitance.
 - B. All input pulses are supplied by generators having the following characteristics: $PRR \leq 1 \text{ MHz}$, $Z_O = 50 \Omega$, $t_r \leq 3 \text{ ns}$, t_f :
 - C. The outputs are measured one at a time, with one input transition per measurement.
 - D. t_{PHL} and t_{PLH} are the same as t_{pd} .

Figure 2. Load Circuit and Voltage Waveforms

PACKAGING INFORMATION

Orderable Device	Status (1)	Package Type	Package Drawing	Pins	Package Qty	Eco Plan (2)	Lead/Ball Finish (6)	MSL Peak Temp (3)	Op Temp (°C)	Device Marking (4/5)	Samples
SN74LV8153N	ACTIVE	PDIP	N	20	20	Pb-Free (RoHS)	CU NIPDAU	N / A for Pkg Type	-40 to 85	SN74LV8153N	Samples
SN74LV8153NE4	ACTIVE	PDIP	N	20	20	Pb-Free (RoHS)	CU NIPDAU	N / A for Pkg Type	-40 to 85	SN74LV8153N	Samples
SN74LV8153PW	ACTIVE	TSSOP	PW	20	70	Green (RoHS & no Sb/Br)	CU NIPDAU	Level-1-260C-UNLIM	-40 to 85	LV8153	Samples
SN74LV8153PWR	ACTIVE	TSSOP	PW	20	2000	Green (RoHS & no Sb/Br)	CU NIPDAU	Level-1-260C-UNLIM	-40 to 85	LV8153	Samples
SN74LV8153PWRG4	ACTIVE	TSSOP	PW	20	2000	Green (RoHS & no Sb/Br)	CU NIPDAU	Level-1-260C-UNLIM	-40 to 85	LV8153	Samples

(1) The marketing status values are defined as follows:

ACTIVE: Product device recommended for new designs.

LIFEBUY: TI has announced that the device will be discontinued, and a lifetime-buy period is in effect.

NRND: Not recommended for new designs. Device is in production to support existing customers, but TI does not recommend using this part in a new design.

PREVIEW: Device has been announced but is not in production. Samples may or may not be available.

OBSOLETE: TI has discontinued the production of the device.

(2) Eco Plan - The planned eco-friendly classification: Pb-Free (RoHS), Pb-Free (RoHS Exempt), or Green (RoHS & no Sb/Br) - please check <http://www.ti.com/productcontent> for the latest availability information and additional product content details.

TBD: The Pb-Free/Green conversion plan has not been defined.

Pb-Free (RoHS): TI's terms "Lead-Free" or "Pb-Free" mean semiconductor products that are compatible with the current RoHS requirements for all 6 substances, including the requirement that lead not exceed 0.1% by weight in homogeneous materials. Where designed to be soldered at high temperatures, TI Pb-Free products are suitable for use in specified lead-free processes.

Pb-Free (RoHS Exempt): This component has a RoHS exemption for either 1) lead-based flip-chip solder bumps used between the die and package, or 2) lead-based die adhesive used between the die and leadframe. The component is otherwise considered Pb-Free (RoHS compatible) as defined above.

Green (RoHS & no Sb/Br): TI defines "Green" to mean Pb-Free (RoHS compatible), and free of Bromine (Br) and Antimony (Sb) based flame retardants (Br or Sb do not exceed 0.1% by weight in homogeneous material)

(3) MSL, Peak Temp. - The Moisture Sensitivity Level rating according to the JEDEC industry standard classifications, and peak solder temperature.

(4) There may be additional marking, which relates to the logo, the lot trace code information, or the environmental category on the device.

(5) Multiple Device Markings will be inside parentheses. Only one Device Marking contained in parentheses and separated by a "~" will appear on a device. If a line is indented then it is a continuation of the previous line and the two combined represent the entire Device Marking for that device.

⁽⁶⁾ Lead/Ball Finish - Orderable Devices may have multiple material finish options. Finish options are separated by a vertical ruled line. Lead/Ball Finish values may wrap to two lines if the finish value exceeds the maximum column width.

Important Information and Disclaimer:The information provided on this page represents TI's knowledge and belief as of the date that it is provided. TI bases its knowledge and belief on information provided by third parties, and makes no representation or warranty as to the accuracy of such information. Efforts are underway to better integrate information from third parties. TI has taken and continues to take reasonable steps to provide representative and accurate information but may not have conducted destructive testing or chemical analysis on incoming materials and chemicals. TI and TI suppliers consider certain information to be proprietary, and thus CAS numbers and other limited information may not be available for release.

In no event shall TI's liability arising out of such information exceed the total purchase price of the TI part(s) at issue in this document sold by TI to Customer on an annual basis.

OTHER QUALIFIED VERSIONS OF SN74LV8153 :

- Automotive: [SN74LV8153-Q1](#)

NOTE: Qualified Version Definitions:

- Automotive - Q100 devices qualified for high-reliability automotive applications targeting zero defects

TAPE AND REEL INFORMATION

REEL DIMENSIONS



TAPE DIMENSIONS



A0	Dimension designed to accommodate the component width
B0	Dimension designed to accommodate the component length
K0	Dimension designed to accommodate the component thickness
W	Overall width of the carrier tape
P1	Pitch between successive cavity centers

TAPE AND REEL INFORMATION

*All dimensions are nominal

Device	Package Type	Package Drawing	Pins	SPQ	Reel Diameter (mm)	Reel Width W1 (mm)	A0 (mm)	B0 (mm)	K0 (mm)	P1 (mm)	W (mm)	Pin1 Quadrant
SN74LV8153PWR	TSSOP	PW	20	2000	330.0	16.4	6.95	7.1	1.6	8.0	16.0	Q1

TAPE AND REEL BOX DIMENSIONS



*All dimensions are nominal

Device	Package Type	Package Drawing	Pins	SPQ	Length (mm)	Width (mm)	Height (mm)
SN74LV8153PWR	TSSOP	PW	20	2000	367.0	367.0	38.0

N (R-PDIP-T**)

PLASTIC DUAL-IN-LINE PACKAGE

16 PINS SHOWN



- NOTES:
- A. All linear dimensions are in inches (millimeters).
 - B. This drawing is subject to change without notice.
 - Falls within JEDEC MS-001, except 18 and 20 pin minimum body length (Dim A).
 - The 20 pin end lead shoulder width is a vendor option, either half or full width.

PW (R-PDSO-G20)

PLASTIC SMALL OUTLINE



4040064-5/G 02/11

- NOTES:
- A. All linear dimensions are in millimeters. Dimensioning and tolerancing per ASME Y14.5M-1994.
 - B. This drawing is subject to change without notice.
 -  Body length does not include mold flash, protrusions, or gate burrs. Mold flash, protrusions, or gate burrs shall not exceed 0,15 each side.
 -  Body width does not include interlead flash. Interlead flash shall not exceed 0,25 each side.
 - E. Falls within JEDEC MO-153

PW (R-PDSO-G20)

PLASTIC SMALL OUTLINE



- NOTES:
- A. All linear dimensions are in millimeters.
 - B. This drawing is subject to change without notice.
 - C. Publication IPC-7351 is recommended for alternate design.
 - D. Laser cutting apertures with trapezoidal walls and also rounding corners will offer better paste release. Customers should contact their board assembly site for stencil design recommendations. Refer to IPC-7525 for other stencil recommendations.
 - E. Customers should contact their board fabrication site for solder mask tolerances between and around signal pads.

IMPORTANT NOTICE

Texas Instruments Incorporated and its subsidiaries (TI) reserve the right to make corrections, enhancements, improvements and other changes to its semiconductor products and services per JESD46, latest issue, and to discontinue any product or service per JESD48, latest issue. Buyers should obtain the latest relevant information before placing orders and should verify that such information is current and complete. All semiconductor products (also referred to herein as "components") are sold subject to TI's terms and conditions of sale supplied at the time of order acknowledgment.

TI warrants performance of its components to the specifications applicable at the time of sale, in accordance with the warranty in TI's terms and conditions of sale of semiconductor products. Testing and other quality control techniques are used to the extent TI deems necessary to support this warranty. Except where mandated by applicable law, testing of all parameters of each component is not necessarily performed.

TI assumes no liability for applications assistance or the design of Buyers' products. Buyers are responsible for their products and applications using TI components. To minimize the risks associated with Buyers' products and applications, Buyers should provide adequate design and operating safeguards.

TI does not warrant or represent that any license, either express or implied, is granted under any patent right, copyright, mask work right, or other intellectual property right relating to any combination, machine, or process in which TI components or services are used. Information published by TI regarding third-party products or services does not constitute a license to use such products or services or a warranty or endorsement thereof. Use of such information may require a license from a third party under the patents or other intellectual property of the third party, or a license from TI under the patents or other intellectual property of TI.

Reproduction of significant portions of TI information in TI data books or data sheets is permissible only if reproduction is without alteration and is accompanied by all associated warranties, conditions, limitations, and notices. TI is not responsible or liable for such altered documentation. Information of third parties may be subject to additional restrictions.

Resale of TI components or services with statements different from or beyond the parameters stated by TI for that component or service voids all express and any implied warranties for the associated TI component or service and is an unfair and deceptive business practice. TI is not responsible or liable for any such statements.

Buyer acknowledges and agrees that it is solely responsible for compliance with all legal, regulatory and safety-related requirements concerning its products, and any use of TI components in its applications, notwithstanding any applications-related information or support that may be provided by TI. Buyer represents and agrees that it has all the necessary expertise to create and implement safeguards which anticipate dangerous consequences of failures, monitor failures and their consequences, lessen the likelihood of failures that might cause harm and take appropriate remedial actions. Buyer will fully indemnify TI and its representatives against any damages arising out of the use of any TI components in safety-critical applications.

In some cases, TI components may be promoted specifically to facilitate safety-related applications. With such components, TI's goal is to help enable customers to design and create their own end-product solutions that meet applicable functional safety standards and requirements. Nonetheless, such components are subject to these terms.

No TI components are authorized for use in FDA Class III (or similar life-critical medical equipment) unless authorized officers of the parties have executed a special agreement specifically governing such use.

Only those TI components which TI has specifically designated as military grade or "enhanced plastic" are designed and intended for use in military/aerospace applications or environments. Buyer acknowledges and agrees that any military or aerospace use of TI components which have **not** been so designated is solely at the Buyer's risk, and that Buyer is solely responsible for compliance with all legal and regulatory requirements in connection with such use.

TI has specifically designated certain components as meeting ISO/TS16949 requirements, mainly for automotive use. In any case of use of non-designated products, TI will not be responsible for any failure to meet ISO/TS16949.

Products

Audio	www.ti.com/audio
Amplifiers	amplifier.ti.com
Data Converters	dataconverter.ti.com
DLP® Products	www.dlp.com
DSP	dsp.ti.com
Clocks and Timers	www.ti.com/clocks
Interface	interface.ti.com
Logic	logic.ti.com
Power Mgmt	power.ti.com
Microcontrollers	microcontroller.ti.com
RFID	www.ti-rfid.com
OMAP Applications Processors	www.ti.com/omap
Wireless Connectivity	www.ti.com/wirelessconnectivity

Applications

Automotive and Transportation	www.ti.com/automotive
Communications and Telecom	www.ti.com/communications
Computers and Peripherals	www.ti.com/computers
Consumer Electronics	www.ti.com/consumer-apps
Energy and Lighting	www.ti.com/energy
Industrial	www.ti.com/industrial
Medical	www.ti.com/medical
Security	www.ti.com/security
Space, Avionics and Defense	www.ti.com/space-avionics-defense
Video and Imaging	www.ti.com/video

TI E2E Community

e2e.ti.com

X-ON Electronics

Largest Supplier of Electrical and Electronic Components

Click to view similar products for [Serial to Parallel Logic Converters](#) category:

Click to view products by [Texas Instruments](#) manufacturer:

Other Similar products are found below :

[HV513K7-G](#) [HV5523K7-G](#) [HV5308PG-B-G-M919](#) [MC74HCT595ADG](#) [MC74HCT595ADTR2G](#) [NLV74HC164ADR2G](#) [HV5623K7-G](#)
[HV57908PG-G](#) [HV507PG-G](#) [HV5122PG-G](#) [HV5122PJ-G](#) [HV513WG-G](#) [HV5622PG-G](#) [HV5222PG-G](#) [HV5222PJ-G](#) [HV53001-E/KWX](#)
[HV53011-E/KVX](#) [HV5308PG-B-G](#) [HV5408PG-B-G](#) [HV5408PJ-B-G](#) [HV5522PJ-G](#) [HV5530PG-G](#) [HV5530PJ-G](#) [HV57009PG-G](#)
[HV57708PG-G](#) [HV5522PG-G](#) [MC100EP445FAG](#) [MC100EP445MNG](#) [MC100EP446MNG](#) [MC10EP445FAG](#) [SN74LV8153NE4](#) [HV528K6-](#)
[G](#) [HV509K6-G](#) [HV5308PJ-B-G](#) [SN74LV8153QPWRG4Q1](#) [SN74LV8153N](#) [SN74LV8153PW](#) [SN74LV8153PWR](#) [SN74LV8153QPWRQ1](#)
[HV5622PJ-G](#)