

TLV1702-Q1 2.2V 至 36V 低功耗比较器

1 特性

- 符合汽车应用要求
- 具有符合 AEC-Q100 的下列结果：
 - 器件温度 1 级：-40°C 至 +125°C 的环境运行温度范围
 - 器件人体模型 (HBM) 分类等级 1C
 - 器件充电器件模型 (CDM) 分类等级 C6
- 电源电压范围：2.2V 至 36V 或 $\pm 1.1V$ 至 $\pm 18V$
- 低静态电流：每个比较器 55 μA
- 输入共模范围包括两个电源轨
- 低传播延迟：560ns
- 低输入偏移电压：300 μV
- 集电极开路输出：
 - 最多可高出负电源电压 36V 且不受电源电压影响
- 工业温度范围：-40°C 至 +125°C
- 小型封装：
 - 双列：超薄小外形尺寸 (VSSOP)-8

2 应用范围

- 过压和欠压检测器
- 窗口比较器
- 过流检测器
- 零交叉检测器
- 针对以下应用的系统监控：
 - 电源
 - 白色家电
 - 工业传感器
 - 汽车
 - 医疗

3 说明

TLV1702-Q1 器件可提供宽电源电压范围、轨到轨输入、低静态电流和低传播延迟。凭借符合行业标准且在极小型封装内集成的上述特性，此类器件成为当前市场中的最佳通用比较器。

集电极开路输出具有能够将输出拉至任意电压轨（最高可高出负电源 36 V）且不受 TLV1702-Q1 电源电压影响的优势。

该器件是一款双通道低功耗比较器。低输入偏移电压、低输入偏置电流、低电源电流和集电极开路配置使 TLV1702-Q1 器件能够灵活处理从简单电压检测到驱动单个继电器的多数应用。

该器件在 -40°C 至 +125°C 的扩展级工业温度范围内额定运行。

器件信息(1)

部件号	封装	封装尺寸 (标称值)
TLV1702-Q1	超薄小外形尺寸封装 (VSSOP) (8)	3.00mm x 3.00mm

(1) 要了解所有可用封装，请参见数据表末尾的封装选项附录。

TLV1702-Q1 用作窗口比较器

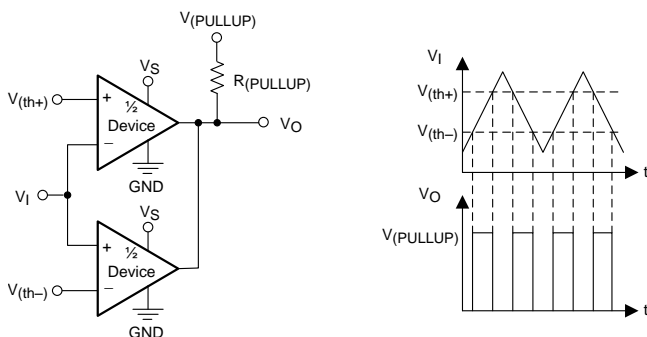

稳定传播延迟与温度

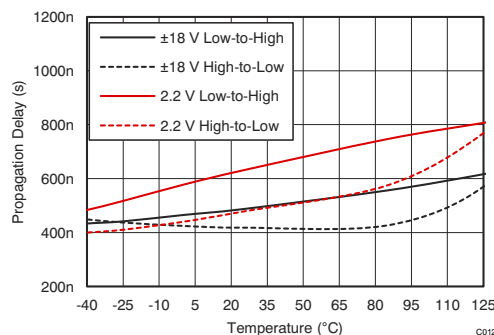

C012



目录

<p>1 特性 1</p> <p>2 应用范围 1</p> <p>3 说明 1</p> <p>4 修订历史记录 2</p> <p>5 Related Products 3</p> <p>6 Pin Configuration and Functions 4</p> <p>7 Specifications 5</p> <p style="padding-left: 20px;">7.1 Absolute Maximum Ratings 5</p> <p style="padding-left: 20px;">7.2 ESD Ratings 5</p> <p style="padding-left: 20px;">7.3 Recommended Operating Conditions 5</p> <p style="padding-left: 20px;">7.4 Thermal Information 5</p> <p style="padding-left: 20px;">7.5 Electrical Characteristics 6</p> <p style="padding-left: 20px;">7.6 Switching Characteristics 6</p> <p style="padding-left: 20px;">7.7 Typical Characteristics 7</p> <p>8 Detailed Description 10</p> <p style="padding-left: 20px;">8.1 Overview 10</p> <p style="padding-left: 20px;">8.2 Functional Block Diagram 10</p>	<p style="padding-left: 20px;">8.3 Feature Description 11</p> <p style="padding-left: 20px;">8.4 Device Functional Modes 11</p> <p>9 Application and Implementation 12</p> <p style="padding-left: 20px;">9.1 Application Information 12</p> <p style="padding-left: 20px;">9.2 Typical Application 12</p> <p>10 Power Supply Recommendations 13</p> <p>11 Layout 14</p> <p style="padding-left: 20px;">11.1 Layout Guidelines 14</p> <p style="padding-left: 20px;">11.2 Layout Example 14</p> <p>12 器件和文档支持 15</p> <p style="padding-left: 20px;">12.1 文档支持 15</p> <p style="padding-left: 20px;">12.2 社区资源 15</p> <p style="padding-left: 20px;">12.3 商标 15</p> <p style="padding-left: 20px;">12.4 静电放电警告 15</p> <p style="padding-left: 20px;">12.5 Glossary 15</p> <p>13 机械、封装和可订购信息 15</p>
---	---

4 修订历史记录

注：之前版本的页码可能与当前版本有所不同。

日期	修订版本	注释
2015 年 11 月	*	最初发布版本。

5 Related Products

DEVICE	FEATURES
TLC3702-Q1	Push-Pull, 20 μ A, 20 mA drive
TLC3704-Q1	
TLV3012-Q1	Push-Pull, 5 μ A, Integrated 1.242-V Reference
TLV3501-Q1	Push-Pull, 3.2 mA, 4.5-ns Propagation Delay
TLV3502-Q1	
TLV3701-Q1	Push-Pull, 560 nA, Reverse Battery to 16 V
TLV3702-Q1	
REF50xx-Q1	Series Reference, 0.1% Tolerance, 8 ppm/ $^{\circ}$ C
TL4050xx-Q1	Shunt Reference, 0.1% Tolerance, 50 ppm/ $^{\circ}$ C
TLVH431-Q1	Adjustable Shunt Reference 1.24 to 18 V

6 Pin Configuration and Functions

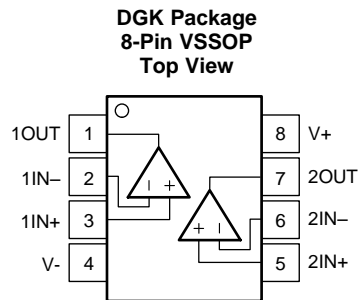

Pin Functions

PIN		I/O	DESCRIPTION
NAME	NO.		
1IN+	3	I	Noninverting input, channel 1
2IN+	5	I	Noninverting input, channel 2
1IN-	2	I	Inverting input, channel 1
2IN-	6	I	Inverting input, channel 2
1OUT	1	O	Output, channel 1
2OUT	7	O	Output, channel 2
V+	8	—	Positive (highest) power supply
V-	4	—	Negative (lowest) power supply

7 Specifications

7.1 Absolute Maximum Ratings

over operating free-air temperature range (unless otherwise noted)⁽¹⁾

		MIN	MAX	UNIT
Supply voltage		40 (±20)		V
Signal input pins	Voltage ⁽²⁾	$(V_{S-}) - 0.5$	$(V_{S+}) + 0.5$	V
	Current ⁽²⁾	±10		mA
Output short-circuit ⁽³⁾		Continuous		mA
Operating temperature		-55	150	°C
Junction temperature, T_J		150		°C
Storage temperature, T_{stg}		-65	150	°C

- (1) Stresses beyond those listed under *Absolute Maximum Ratings* may cause permanent damage to the device. These are stress ratings only, and functional operation of the device at these or any other conditions beyond those indicated under *Recommended Operating Conditions* is not implied. Exposure to absolute-maximum-rated conditions for extended periods may affect device reliability.
- (2) Input pins are diode-clamped to the power-supply rails. Input signals that can swing more than 0.5 V beyond the supply rails must be current limited to 10 mA or less.
- (3) Short-circuit to ground; one comparator per package.

7.2 ESD Ratings

		VALUE	UNIT
$V_{(ESD)}$	Electrostatic discharge	Human-body model (HBM), per AEC Q100-002 ⁽¹⁾	±1000
		Charged-device model (CDM), per AEC Q100-011	±1000

- (1) AEC Q100-002 indicates that HBM stressing shall be in accordance with the ANSI/ESDA/JEDEC JS-001 specification.

7.3 Recommended Operating Conditions

over operating free-air temperature range (unless otherwise noted)

	MIN	NOM	MAX	UNIT
Supply voltage $V_S = (V_{S+}) - (V_{S-})$	2.2 (±1.1)		36 (±18)	V
Specified temperature	-40		125	°C

7.4 Thermal Information

THERMAL METRIC ⁽¹⁾		TLV1702-Q1	UNIT
		DGK (VSSOP)	
		8 PINS	
$R_{\theta JA}$	Junction-to-ambient thermal resistance	199	°C/W
$R_{\theta JC(top)}$	Junction-to-case (top) thermal resistance	89.5	°C/W
$R_{\theta JB}$	Junction-to-board thermal resistance	120.4	°C/W
Ψ_{JT}	Junction-to-top characterization parameter	22	°C/W
Ψ_{JB}	Junction-to-board characterization parameter	118.7	°C/W
$R_{\theta JC(bot)}$	Junction-to-case (bottom) thermal resistance	N/A	°C/W

- (1) For more information about traditional and new thermal metrics, see the *Semiconductor and IC Package Thermal Metrics* application report, [SPRA953](#).

7.5 Electrical Characteristics

 at $T_A = 25^\circ\text{C}$, $V_S = 2.2\text{ V to }36\text{ V}$, $C_L = 15\text{ pF}$, $R_{PULLUP} = 5.1\text{ k}\Omega$, $V_{CM} = V_S / 2$, and $V_S = V_{PULLUP}$ (unless otherwise noted)

PARAMETER		TEST CONDITIONS	MIN	TYP	MAX	UNIT
OFFSET VOLTAGE						
V_{OS}	Input offset voltage	$T_A = 25^\circ\text{C}$, $V_S = 2.2\text{ V}$		± 0.5	± 3.5	mV
		$T_A = 25^\circ\text{C}$, $V_S = 36\text{ V}$		± 0.3	± 2.5	mV
		$T_A = -40^\circ\text{C to }+125^\circ\text{C}$			± 5.5	mV
dV_{OS}/dT	Input offset voltage drift	$T_A = -40^\circ\text{C to }+125^\circ\text{C}$		± 4	± 20	$\mu\text{V}/^\circ\text{C}$
PSRR	Power-supply rejection ratio	$T_A = 25^\circ\text{C}$		15	100	$\mu\text{V}/\text{V}$
		$T_A = -40^\circ\text{C to }+125^\circ\text{C}$		20		$\mu\text{V}/\text{V}$
INPUT VOLTAGE RANGE						
V_{CM}	Common-mode voltage range	$T_A = -40^\circ\text{C to }+125^\circ\text{C}$	(V-)		(V+)	V
INPUT BIAS CURRENT						
I_B	Input bias current	$T_A = 25^\circ\text{C}$		5	15	nA
		$T_A = -40^\circ\text{C to }+125^\circ\text{C}$			20	nA
I_{OS}	Input offset current			0.5		nA
C_{LOAD}	Capacitive load drive		See Typical Characteristics			
OUTPUT						
V_O	Voltage output swing from rail	$I_O \leq 4\text{ mA}$, input overdrive = 100 mV, $V_S = 36\text{ V}$			900	mV
		$I_O = 0\text{ mA}$, input overdrive = 100 mV, $V_S = 36\text{ V}$			600	mV
I_{SC}	Short circuit sink current			20		mA
	Output leakage current	$V_{IN+} > V_{IN-}$		70		nA
POWER SUPPLY						
V_S	Specified voltage range		2.2		36	V
I_Q	Quiescent current (per channel)	$I_O = 0\text{ A}$		55	75	μA
		$I_O = 0\text{ A}$, $T_A = -40^\circ\text{C to }+125^\circ\text{C}$			100	μA

7.6 Switching Characteristics

 at $T_A = 25^\circ\text{C}$, $V_S = +2.2\text{ V to }+36\text{ V}$, $C_L = 15\text{ pF}$, $R_{PULLUP} = 5.1\text{ k}\Omega$, $V_{CM} = V_S / 2$, and $V_S = V_{PULLUP}$ (unless otherwise noted)

PARAMETER		TEST CONDITIONS	MIN	TYP	MAX	UNIT
t_{pHL}	Propagation delay time, high-to-low	Input overdrive = 100 mV		460		ns
t_{pLH}	Propagation delay time, low-to-high	Input overdrive = 100 mV		560		ns
t_R	Rise time	Input overdrive = 100 mV		365		ns
t_F	Fall time	Input overdrive = 100 mV		240		ns

7.7 Typical Characteristics

at $T_A = 25^\circ\text{C}$, $V_S = 5\text{ V}$, $R_{\text{PULLUP}} = 5.1\text{ k}\Omega$, and input overdrive = 100 mV (unless otherwise noted)

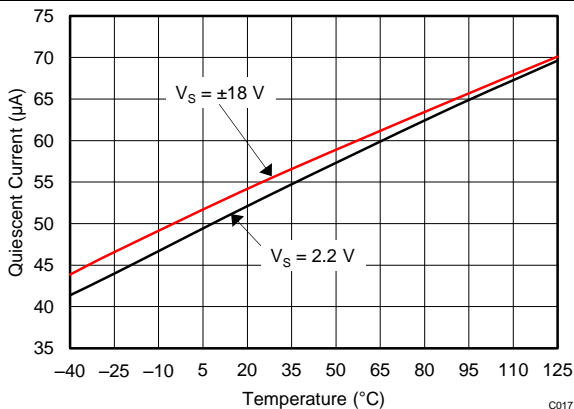

Figure 1. Quiescent Current vs Temperature

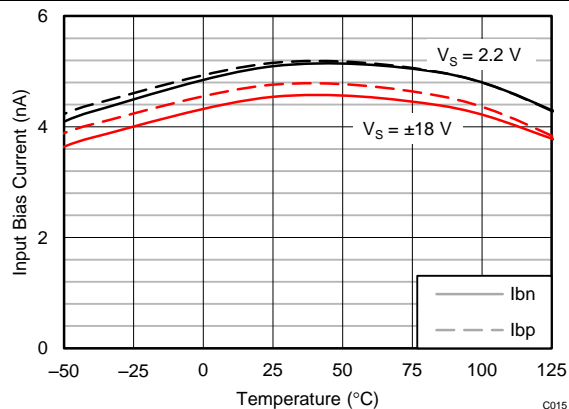

Figure 2. Input Bias Current vs Temperature

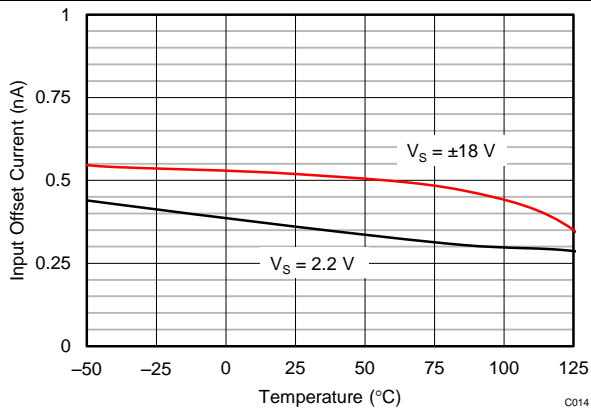

Figure 3. Input Offset Current vs Temperature

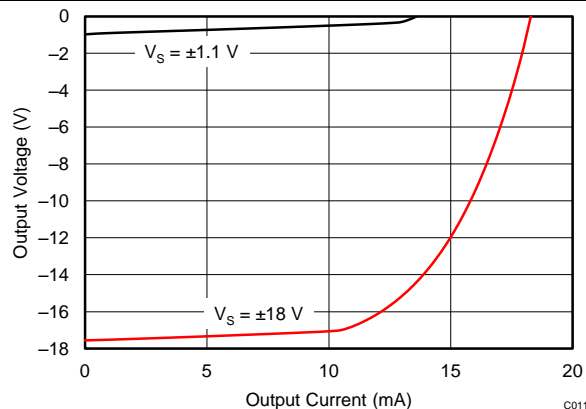

Figure 4. Output Voltage vs Output Current

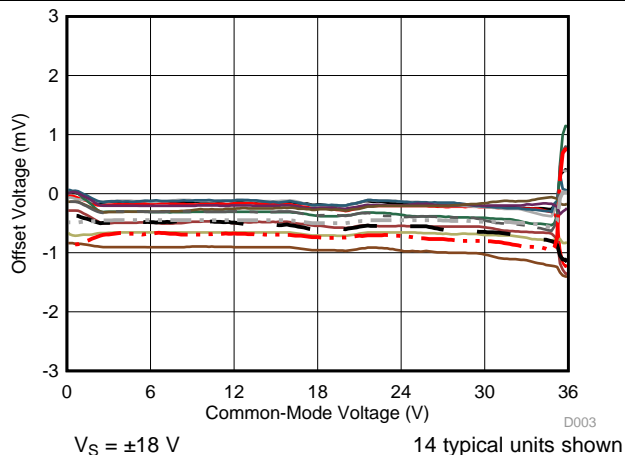

Figure 5. Offset Voltage vs Common-Mode Voltage

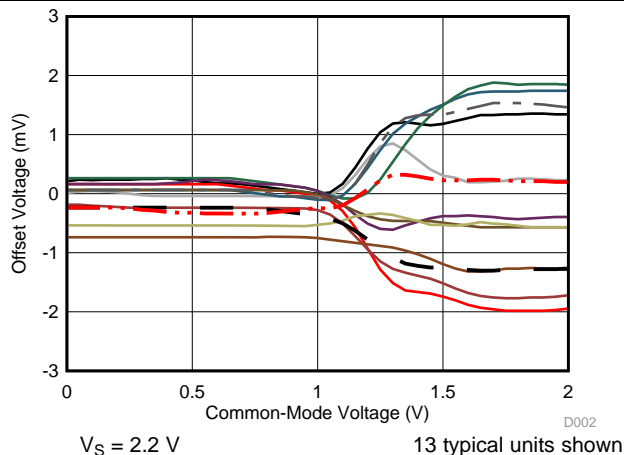

Figure 6. Offset Voltage vs Common-Mode Voltage

Typical Characteristics (continued)

at $T_A = 25^\circ\text{C}$, $V_S = 5\text{ V}$, $R_{PULLUP} = 5.1\text{ k}\Omega$, and input overdrive = 100 mV (unless otherwise noted)

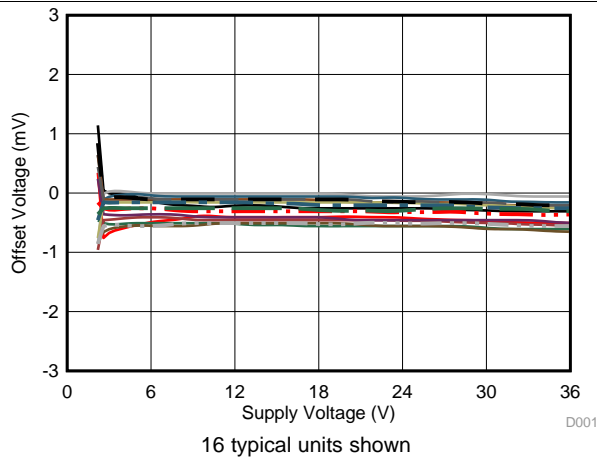

Figure 7. Offset Voltage vs Supply Voltage

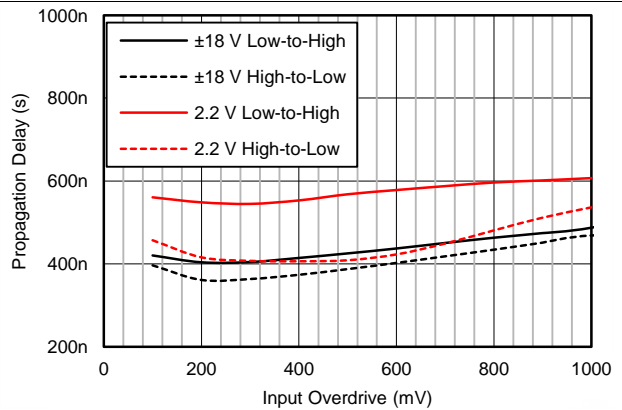

Figure 8. Propagation Delay vs Input Overdrive

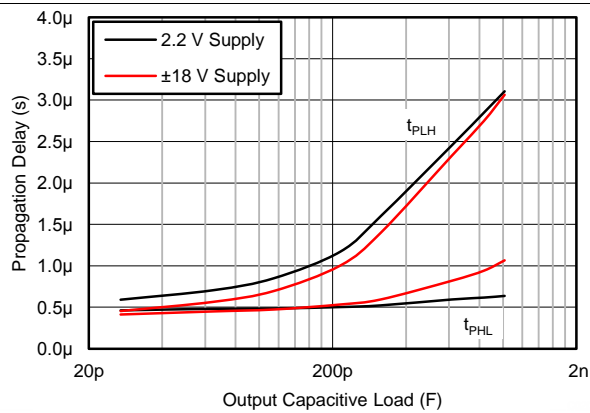

Figure 9. Propagation Delay vs Capacitive Load

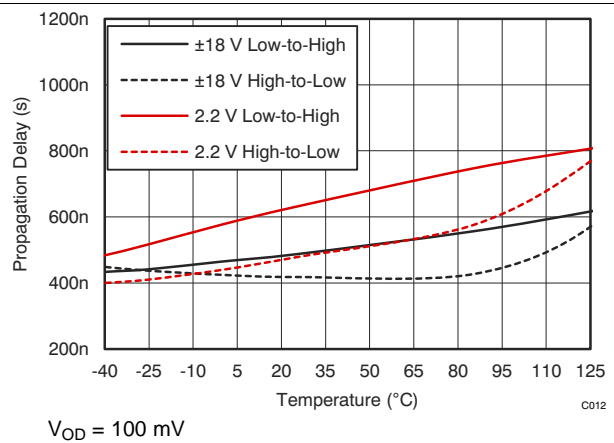

Figure 10. Propagation Delay vs Temperature

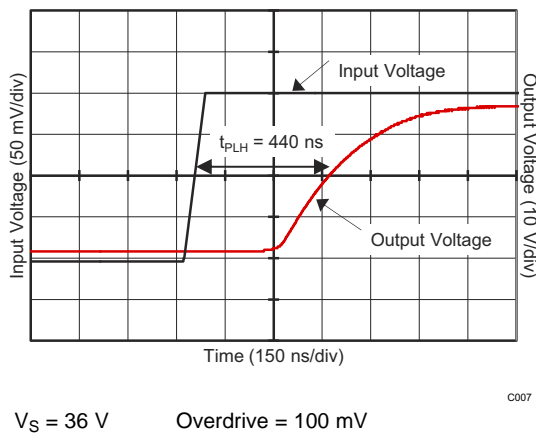

Figure 11. Propagation Delay (T_{PLH})

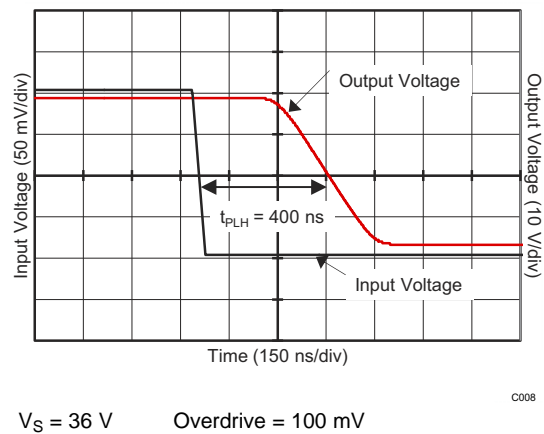
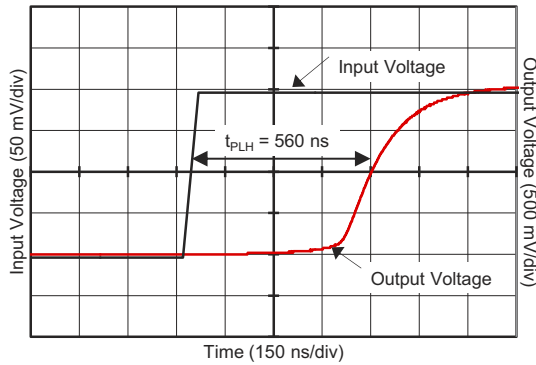

Figure 12. Propagation Delay (T_{PHL})

Typical Characteristics (continued)

at $T_A = 25^\circ\text{C}$, $V_S = 5\text{ V}$, $R_{\text{PULLUP}} = 5.1\text{ k}\Omega$, and input overdrive = 100 mV (unless otherwise noted)



$V_S = 2.2\text{ V}$ Overdrive = 100 mV

C009

Figure 13. Propagation Delay (T_{pLH})

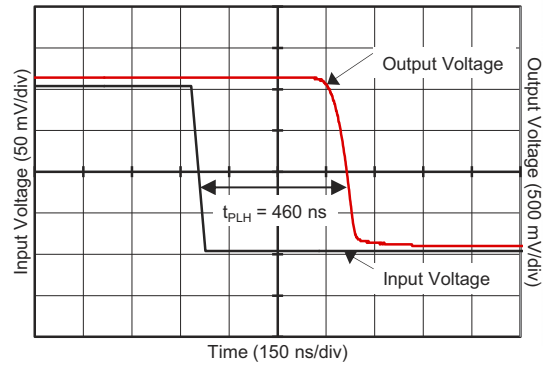

$V_S = 2.2\text{ V}$ Overdrive = 100 mV

C010

Figure 14. Propagation Delay (T_{pHL})

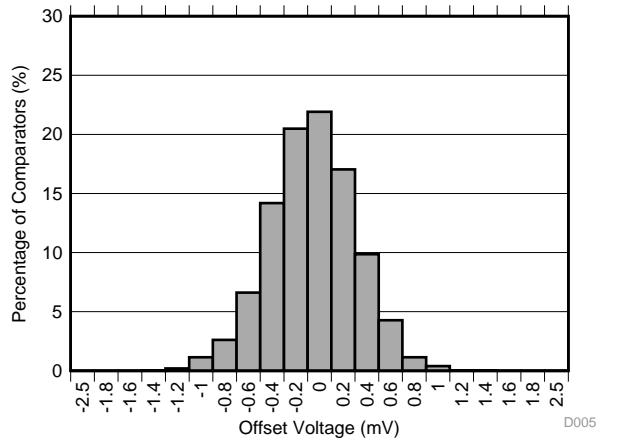

Figure 15. Offset Voltage Production Distribution

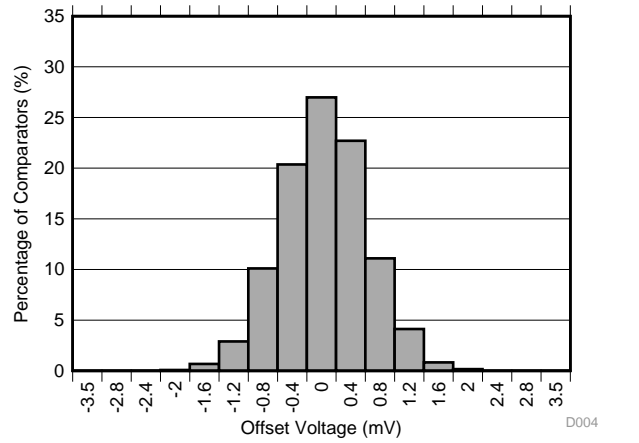

Figure 16. Offset Voltage Production Distribution

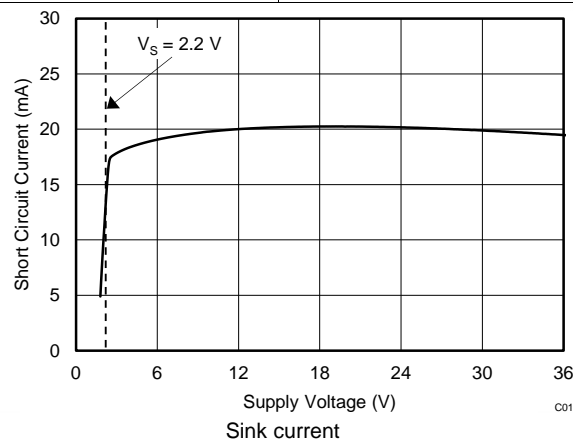

Figure 17. Short-Circuit Current vs Supply Voltage

8 Detailed Description

8.1 Overview

The TLV1702-Q1 comparator features rail-to-rail input and output on supply voltages as high as 36 V. The rail-to-rail input stage enables detection of signals close to the supply and ground. The open collector configuration allows the device to be used in wired-OR configurations, such as a window comparator. A low supply current of 55 μA per channel with small, space-saving packages, makes these comparators versatile for use in a wide range of applications, from portable to industrial.

8.2 Functional Block Diagram

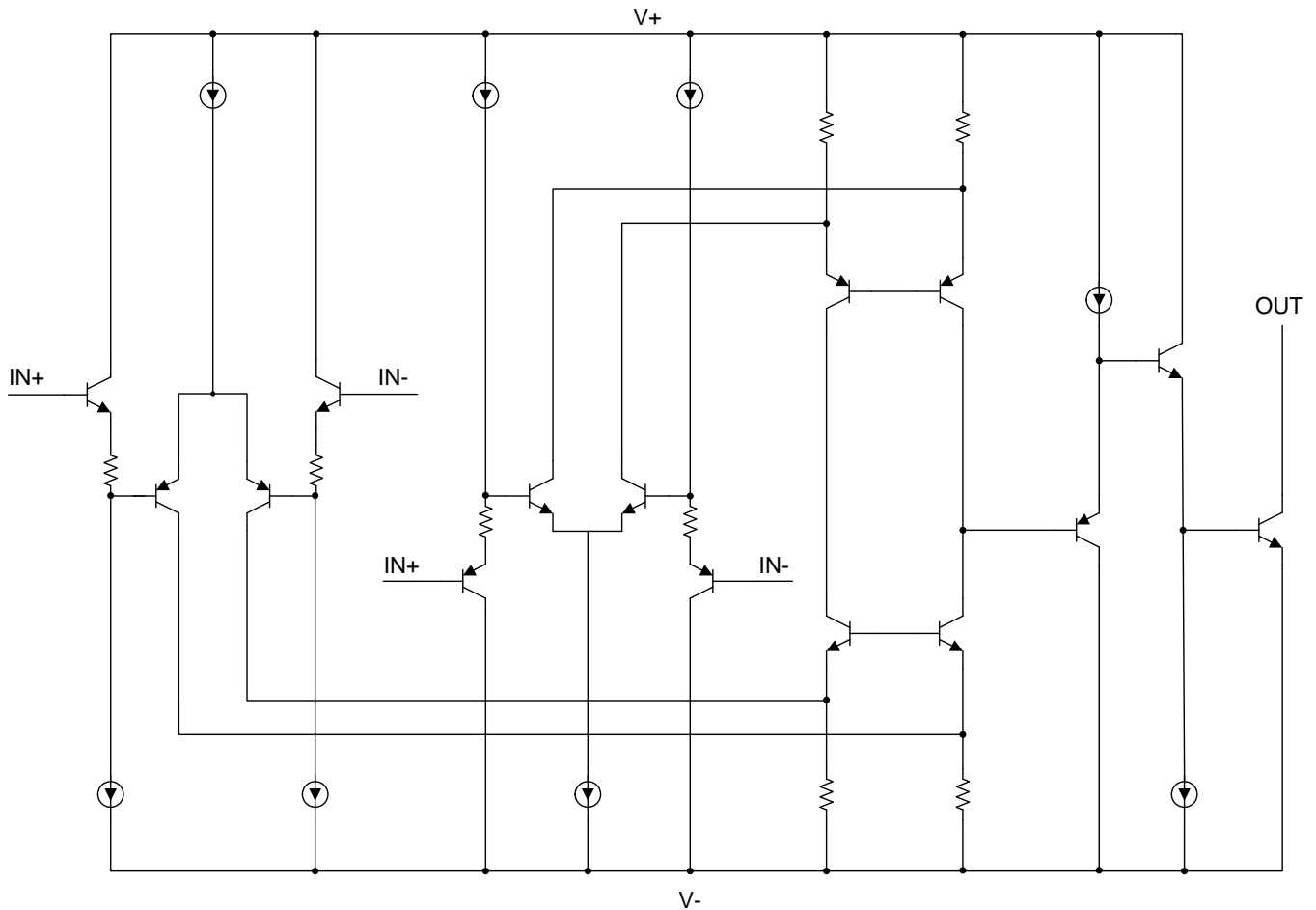

8.3 Feature Description

8.3.1 Comparator Inputs

The TLV1702-Q1 device is a rail-to-rail input comparator, with an input common-mode range that includes the supply rails. The TLV1702-Q1 device is designed to prevent phase inversion when the input pins exceed the supply voltage. Figure 18 shows the TLV1702-Q1 device response when input voltages exceed the supply, resulting in no phase inversion.

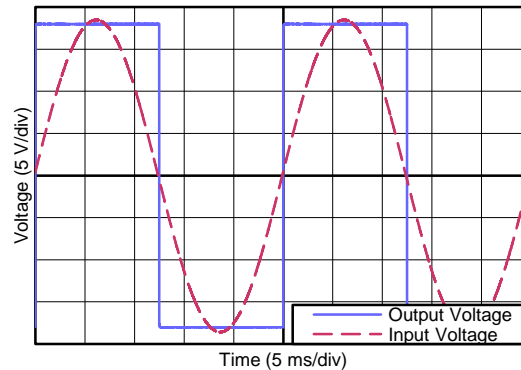

Figure 18. No Phase Inversion: Comparator Response to Input Voltage (Propagation Delay Included)

8.4 Device Functional Modes

8.4.1 Setting Reference Voltage

Using a stable reference is important when setting the transition point for the TLV1702-Q1 device. The REF3333, as shown in Figure 19, provides a 3.3-V reference voltage with low drift and only 3.9 μ A of quiescent current.

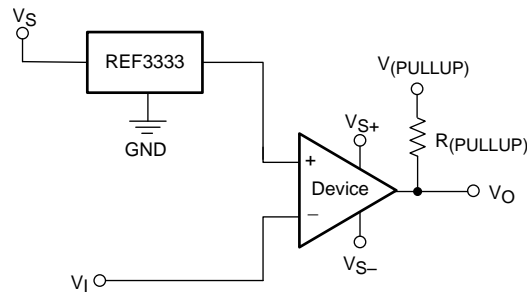

Figure 19. Reference Voltage for the TLV1702-Q1

9 Application and Implementation

NOTE

Information in the following applications sections is not part of the TI component specification, and TI does not warrant its accuracy or completeness. TI's customers are responsible for determining suitability of components for their purposes. Customers should validate and test their design implementation to confirm system functionality.

9.1 Application Information

The TLV1702-Q1 device can be used in a wide variety of applications, such as zero crossing detectors, window comparators, over and undervoltage detectors, and high-side voltage sense circuits.

9.2 Typical Application

Comparators are used to differentiate between two different signal levels. For example, a comparator differentiates between an overtemperature and normal-temperature condition. However, noise or signal variation at the comparison threshold causes multiple transitions. This application example sets upper and lower hysteresis thresholds to eliminate the multiple transitions caused by noise.

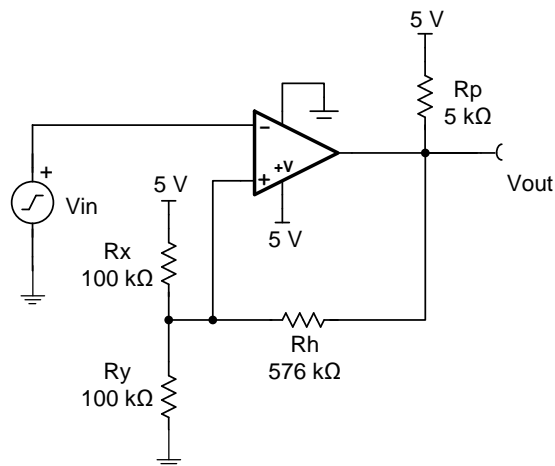

Figure 20. Comparator Schematic with Hysteresis

9.2.1 Design Requirements

The design requirements are as follows:

- Supply voltage: 5 V
- Input: 0 V to 5 V
- Lower threshold (VL) = 2.3 V ±0.1 V
- Upper threshold (VH) = 2.7 V ±0.1 V
- VH – VL = 2.4 V ±0.1 V
- Low-power consumption

Typical Application (continued)

9.2.2 Detailed Design Procedure

Make a small change to the comparator circuit to add hysteresis. Hysteresis uses two different threshold voltages to avoid the multiple transitions introduced in the previous circuit. The input signal must exceed the upper threshold (VH) to transition low, or below the lower threshold (VL) to transition high.

Figure 20 illustrates hysteresis on a comparator. Resistor Rh sets the hysteresis level. An open-collector output stage requires a pullup resistor (Rp). The pullup resistor creates a voltage divider at the comparator output that introduces an error when the output is at logic high. This error can be minimized if $R_h > 100 R_p$.

When the output is at a logic high (5 V), Rh is in parallel with Rx (ignoring Rp). This configuration drives more current into Ry, and raises the threshold voltage (VH) to 2.7 V. The input signal must drive above $V_H = 2.7$ V to cause the output to transition to logic low (0 V).

When the output is at logic low (0 V), Rh is in parallel with Ry. This configuration reduces the current into Ry, and reduces the threshold voltage to 2.3 V. The input signal must drive below $V_L = 2.3$ V to cause the output to transition to logic high (5 V).

For more details on this design and other alternative devices that can be used in place of the TLV1702, refer to Precision Design TIPD144, *Comparator with Hysteresis Reference Design*.

9.2.3 Application Curve

Figure 21 shows the upper and lower thresholds for hysteresis. The upper threshold is 2.76 V and the lower threshold is 2.34 V, both of which are close to the design target.

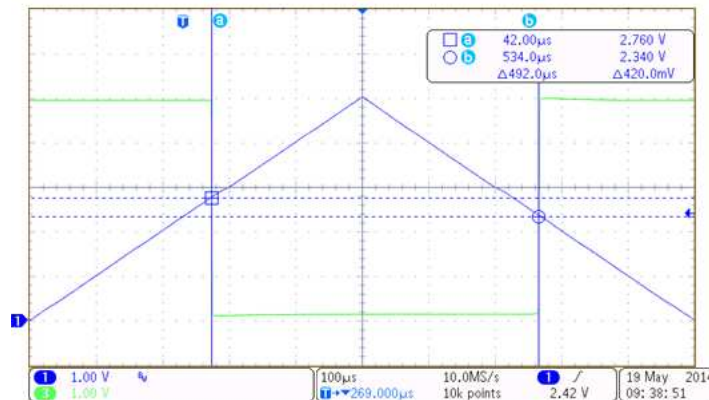

Figure 21. TLV1701 Upper and Lower Threshold with Hysteresis

10 Power Supply Recommendations

The TLV1702-Q1 device is specified for operation from 2.2 V to 36 V (± 1.1 to ± 18 V); many specifications apply from -40°C to $+125^{\circ}\text{C}$. Parameters that can exhibit significant variance with regard to operating voltage or temperature are presented in the *Typical Characteristics* section.

CAUTION

Supply voltages larger than 40 V can permanently damage the device; see the *Absolute Maximum Ratings*.

Place 0.1- μF bypass capacitors close to the power-supply pins to reduce errors coupling in from noisy or high-impedance power supplies. For more detailed information on bypass capacitor placement; see the *Layout Guidelines* section.

11 Layout

11.1 Layout Guidelines

Comparators are very sensitive to input noise. For best results, maintain the following layout guidelines:

- Use a printed circuit board (PCB) with a good, unbroken low-inductance ground plane. Proper grounding (use of ground plane) helps maintain specified performance of the TLV1702-Q1 device.
- To minimize supply noise, place a decoupling capacitor (0.1- μ F ceramic, surface-mount capacitor) as close as possible to V_S as shown in Figure 22.
- On the inputs and the output, keep lead lengths as short as possible to avoid unwanted parasitic feedback around the comparator. Keep inputs away from the output.
- Solder the device directly to the PCB rather than using a socket.
- For slow-moving input signals, take care to prevent parasitic feedback. A small capacitor (1000 pF or less) placed between the inputs can help eliminate oscillations in the transition region. This capacitor causes some degradation to propagation delay when the impedance is low. Run the topside ground plane between the output and inputs.
- Run the ground pin ground trace under the device up to the bypass capacitor, shielding the inputs from the outputs.

11.2 Layout Example

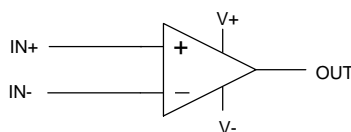

(Schematic Representation)

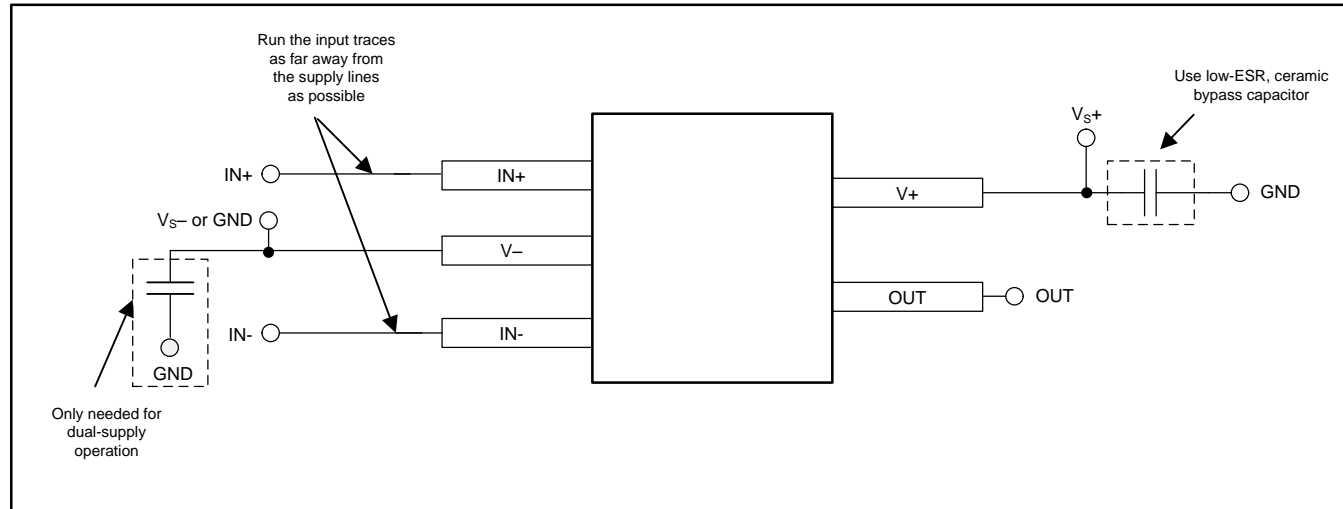

Figure 22. Comparator Board Layout

12 器件和文档支持

12.1 文档支持

12.1.1 相关文档

相关文档如下：

- 《高精度设计，采用滞后参考设计的比较器》， [TIDU020](#)
- 《REF33xx 3.9μA, SC70-3、SOT-23-3 和 UQFN-8, 30ppm/°C 漂移电压基准》， [SBOS392](#)

12.2 社区资源

The following links connect to TI community resources. Linked contents are provided "AS IS" by the respective contributors. They do not constitute TI specifications and do not necessarily reflect TI's views; see TI's [Terms of Use](#).

TI E2E™ Online Community *TI's Engineer-to-Engineer (E2E) Community*. Created to foster collaboration among engineers. At e2e.ti.com, you can ask questions, share knowledge, explore ideas and help solve problems with fellow engineers.

Design Support *TI's Design Support* Quickly find helpful E2E forums along with design support tools and contact information for technical support.

12.3 商标

E2E is a trademark of Texas Instruments.

All other trademarks are the property of their respective owners.

12.4 静电放电警告



ESD 可能会损坏该集成电路。德州仪器 (TI) 建议通过适当的预防措施处理所有集成电路。如果不遵守正确的处理措施和安装程序，可能会损坏集成电路。

ESD 的损坏小至导致微小的性能降级，大至整个器件故障。精密的集成电路可能更容易受到损坏，这是因为非常细微的参数更改都可能会导致器件与其发布的规格不相符。

12.5 Glossary

[SLYZ022](#) — *TI Glossary*.

This glossary lists and explains terms, acronyms, and definitions.

13 机械、封装和可订购信息

以下页中包括机械封装、封装和可订购信息。 这些信息是针对指定器件可提供的最新数据。 这些数据会在无通知且不对本文档进行修订的情况下发生改变。 欲获得该数据表的浏览器版本，请查阅左侧的导航栏。

重要声明

德州仪器(TI)及其下属子公司有权根据 JESD46 最新标准,对所提供的产品和服务进行更正、修改、增强、改进或其它更改,并有权根据 JESD48 最新标准中止提供任何产品和服务。客户在下订单前应获取最新的相关信息,并验证这些信息是否完整且是最新的。所有产品的销售都遵循在订单确认时所提供的TI 销售条款与条件。

TI 保证其所销售的组件的性能符合产品销售时 TI 半导体产品销售条件与条款的适用规范。仅在 TI 保证的范围内,且 TI 认为有必要时才会使用测试或其它质量控制技术。除非适用法律做出了硬性规定,否则没有必要对每种组件的所有参数进行测试。

TI 对应用帮助或客户产品设计不承担任何义务。客户应对其使用 TI 组件的产品和应用自行负责。为尽量减小与客户产品和应用相关的风险,客户应提供充分的设计与操作安全措施。

TI 不对任何 TI 专利权、版权、屏蔽作品权或其它与使用了 TI 组件或服务的组合设备、机器或流程相关的 TI 知识产权中授予的直接或隐含权限作出任何保证或解释。TI 所发布的与第三方产品或服务有关的信息,不能构成从 TI 获得使用这些产品或服务的许可、授权、或认可。使用此类信息可能需要获得第三方的专利权或其它知识产权方面的许可,或是 TI 的专利权或其它知识产权方面的许可。

对于 TI 的产品手册或数据表中 TI 信息的重要部分,仅在没有对内容进行任何篡改且带有相关授权、条件、限制和声明的情况下才允许进行复制。TI 对此类篡改过的文件不承担任何责任或义务。复制第三方的信息可能需要服从额外的限制条件。

在转售 TI 组件或服务时,如果对该组件或服务参数的陈述与 TI 标明的参数相比存在差异或虚假成分,则会失去相关 TI 组件或服务的所有明示或暗示授权,且这是不正当的、欺诈性商业行为。TI 对任何此类虚假陈述均不承担任何责任或义务。

客户认可并同意,尽管任何应用相关信息或支持仍可能由 TI 提供,但他们将独立负责满足与其产品及其在应用中使用的 TI 产品相关的所有法律、法规和安全相关要求。客户声明并同意,他们具备制定与实施安全措施所需的全部专业技术和知识,可预见故障的危险后果、监测故障及其后果、降低有可能造成人身伤害的故障的发生机率并采取适当的补救措施。客户将全额赔偿因在此类安全关键应用中使用任何 TI 组件而对 TI 及其代理造成的任何损失。

在某些场合中,为了推进安全相关应用有可能对 TI 组件进行特别的促销。TI 的目标是利用此类组件帮助客户设计和创立其特有的可满足适用的功能安全性标准和要求的终端产品解决方案。尽管如此,此类组件仍然服从这些条款。

TI 组件未获得用于 FDA Class III (或类似的生命攸关医疗设备)的授权许可,除非各方授权官员已经达成了专门管控此类使用的特别协议。

只有那些 TI 特别注明属于军用等级或“增强型塑料”的 TI 组件才是设计或专门用于军事/航空应用或环境的。购买者认可并同意,对并非指定面向军事或航空航天用途的 TI 组件进行军事或航空航天方面的应用,其风险由客户单独承担,并且由客户独立负责满足与此类使用相关的所有法律和法规要求。

TI 已明确指定符合 ISO/TS16949 要求的产品,这些产品主要用于汽车。在任何情况下,因使用非指定产品而无法达到 ISO/TS16949 要求, TI 不承担任何责任。

	产品		应用
数字音频	www.ti.com.cn/audio	通信与电信	www.ti.com.cn/telecom
放大器和线性器件	www.ti.com.cn/amplifiers	计算机及周边	www.ti.com.cn/computer
数据转换器	www.ti.com.cn/dataconverters	消费电子	www.ti.com.cn/consumer-apps
DLP® 产品	www.dlp.com	能源	www.ti.com.cn/energy
DSP - 数字信号处理器	www.ti.com.cn/dsp	工业应用	www.ti.com.cn/industrial
时钟和计时器	www.ti.com.cn/clockandtimers	医疗电子	www.ti.com.cn/medical
接口	www.ti.com.cn/interface	安防应用	www.ti.com.cn/security
逻辑	www.ti.com.cn/logic	汽车电子	www.ti.com.cn/automotive
电源管理	www.ti.com.cn/power	视频和影像	www.ti.com.cn/video
微控制器 (MCU)	www.ti.com.cn/microcontrollers		
RFID 系统	www.ti.com.cn/rfidsys		
OMAP应用处理器	www.ti.com/omap		
无线连通性	www.ti.com.cn/wirelessconnectivity	德州仪器在线技术支持社区	www.deyisupport.com

邮寄地址: 上海市浦东新区世纪大道1568号, 中建大厦32楼邮政编码: 200122
Copyright © 2015, 德州仪器半导体技术(上海)有限公司

PACKAGING INFORMATION

Orderable Device	Status (1)	Package Type	Package Drawing	Pins	Package Qty	Eco Plan (2)	Lead/Ball Finish (6)	MSL Peak Temp (3)	Op Temp (°C)	Device Marking (4/5)	Samples
TLV1702AQDGKRQ1	ACTIVE	VSSOP	DGK	8	2500	Green (RoHS & no Sb/Br)	CU NIPDAUAG	Level-2-260C-1 YEAR	-40 to 125	1702Q	Samples

(1) The marketing status values are defined as follows:

ACTIVE: Product device recommended for new designs.

LIFEBUY: TI has announced that the device will be discontinued, and a lifetime-buy period is in effect.

NRND: Not recommended for new designs. Device is in production to support existing customers, but TI does not recommend using this part in a new design.

PREVIEW: Device has been announced but is not in production. Samples may or may not be available.

OBSELETE: TI has discontinued the production of the device.

(2) Eco Plan - The planned eco-friendly classification: Pb-Free (RoHS), Pb-Free (RoHS Exempt), or Green (RoHS & no Sb/Br) - please check <http://www.ti.com/productcontent> for the latest availability information and additional product content details.

TBD: The Pb-Free/Green conversion plan has not been defined.

Pb-Free (RoHS): TI's terms "Lead-Free" or "Pb-Free" mean semiconductor products that are compatible with the current RoHS requirements for all 6 substances, including the requirement that lead not exceed 0.1% by weight in homogeneous materials. Where designed to be soldered at high temperatures, TI Pb-Free products are suitable for use in specified lead-free processes.

Pb-Free (RoHS Exempt): This component has a RoHS exemption for either 1) lead-based flip-chip solder bumps used between the die and package, or 2) lead-based die adhesive used between the die and leadframe. The component is otherwise considered Pb-Free (RoHS compatible) as defined above.

Green (RoHS & no Sb/Br): TI defines "Green" to mean Pb-Free (RoHS compatible), and free of Bromine (Br) and Antimony (Sb) based flame retardants (Br or Sb do not exceed 0.1% by weight in homogeneous material)

(3) MSL, Peak Temp. - The Moisture Sensitivity Level rating according to the JEDEC industry standard classifications, and peak solder temperature.

(4) There may be additional marking, which relates to the logo, the lot trace code information, or the environmental category on the device.

(5) Multiple Device Markings will be inside parentheses. Only one Device Marking contained in parentheses and separated by a "~" will appear on a device. If a line is indented then it is a continuation of the previous line and the two combined represent the entire Device Marking for that device.

(6) Lead/Ball Finish - Orderable Devices may have multiple material finish options. Finish options are separated by a vertical ruled line. Lead/Ball Finish values may wrap to two lines if the finish value exceeds the maximum column width.

Important Information and Disclaimer:The information provided on this page represents TI's knowledge and belief as of the date that it is provided. TI bases its knowledge and belief on information provided by third parties, and makes no representation or warranty as to the accuracy of such information. Efforts are underway to better integrate information from third parties. TI has taken and continues to take reasonable steps to provide representative and accurate information but may not have conducted destructive testing or chemical analysis on incoming materials and chemicals. TI and TI suppliers consider certain information to be proprietary, and thus CAS numbers and other limited information may not be available for release.

In no event shall TI's liability arising out of such information exceed the total purchase price of the TI part(s) at issue in this document sold by TI to Customer on an annual basis.

DGK (S-PDSO-G8)

PLASTIC SMALL-OUTLINE PACKAGE



- NOTES:
- A. All linear dimensions are in millimeters.
 - B. This drawing is subject to change without notice.
 - C. Body length does not include mold flash, protrusions, or gate burrs. Mold flash, protrusions, or gate burrs shall not exceed 0.15 per end.
 - D. Body width does not include interlead flash. Interlead flash shall not exceed 0.50 per side.
 - E. Falls within JEDEC MO-187 variation AA, except interlead flash.



- NOTES:
- A. All linear dimensions are in millimeters.
 - B. This drawing is subject to change without notice.
 - C. Publication IPC-7351 is recommended for alternate designs.
 - D. Laser cutting apertures with trapezoidal walls and also rounding corners will offer better paste release. Customers should contact their board assembly site for stencil design recommendations. Refer to IPC-7525 for other stencil recommendations.
 - E. Customers should contact their board fabrication site for solder mask tolerances between and around signal pads.

重要声明

德州仪器(TI) 及其下属子公司有权根据 JESD46 最新标准, 对所提供的产品和服务进行更正、修改、增强、改进或其它更改, 并有权根据 JESD48 最新标准中止提供任何产品和服务。客户在下订单前应获取最新的相关信息, 并验证这些信息是否完整且是最新的。所有产品的销售都遵循在订单确认时所提供的TI 销售条款与条件。

TI 保证其所销售的组件的性能符合产品销售时 TI 半导体产品销售条件与条款的适用规范。仅在 TI 保证的范围内, 且 TI 认为有必要时才会使用测试或其它质量控制技术。除非适用法律做出了硬性规定, 否则没有必要对每种组件的所有参数进行测试。

TI 对应用帮助或客户产品设计不承担任何义务。客户应对其使用 TI 组件的产品和应用自行负责。为尽量减小与客户产品和应用相关的风险, 客户应提供充分的设计与操作安全措施。

TI 不对任何 TI 专利权、版权、屏蔽作品权或其它与使用了 TI 组件或服务的组合设备、机器或流程相关的 TI 知识产权中授予的直接或间接版权限作出任何保证或解释。TI 所发布的与第三方产品或服务有关的信息, 不能构成从 TI 获得使用这些产品或服务的许可、授权、或认可。使用此类信息可能需要获得第三方的专利权或其它知识产权方面的许可, 或是 TI 的专利权或其它知识产权方面的许可。

对于 TI 的产品手册或数据表中 TI 信息的重要部分, 仅在没有对内容进行任何篡改且带有相关授权、条件、限制和声明的情况下才允许进行复制。TI 对此类篡改过的文件不承担任何责任或义务。复制第三方的信息可能需要服从额外的限制条件。

在转售 TI 组件或服务时, 如果对该组件或服务参数的陈述与 TI 标明的参数相比存在差异或虚假成分, 则会失去相关 TI 组件或服务的所有明示或暗示授权, 且这是不正当的、欺诈性商业行为。TI 对任何此类虚假陈述均不承担任何责任或义务。

客户认可并同意, 尽管任何应用相关信息或支持仍可能由 TI 提供, 但他们将独自负责满足与其产品及其应用中使用 TI 产品相关的所有法律、法规和安全相关要求。客户声明并同意, 他们具备制定与实施安全措施所需的全部专业技术和知识, 可预见故障的危险后果、监测故障及其后果、降低有可能造成人身伤害的故障的发生机率并采取适当的补救措施。客户将全额赔偿因在此类安全关键应用中使用任何 TI 组件而对 TI 及其代理造成的任何损失。

在某些场合中, 为了推进安全相关应用有可能对 TI 组件进行特别的促销。TI 的目标是利用此类组件帮助客户设计和创立其特有的可满足适用的功能安全性标准和要求的终端产品解决方案。尽管如此, 此类组件仍然服从这些条款。

TI 组件未获得用于 FDA Class III (或类似的生命攸关医疗设备) 的授权许可, 除非各方授权官员已经达成了专门管控此类使用的特别协议。

只有那些 TI 特别注明属于军用等级或“增强型塑料”的 TI 组件才是设计或专门用于军事/航空应用或环境的。购买者认可并同意, 对并非指定面向军事或航空航天用途的 TI 组件进行军事或航空航天方面的应用, 其风险由客户单独承担, 并且由客户独自负责满足与此类使用相关的所有法律和法规要求。

TI 已明确指定符合 ISO/TS16949 要求的产品, 这些产品主要用于汽车。在任何情况下, 因使用非指定产品而无法达到 ISO/TS16949 要求, TI 不承担任何责任。

	产品		应用
数字音频	www.ti.com.cn/audio	通信与电信	www.ti.com.cn/telecom
放大器和线性器件	www.ti.com.cn/amplifiers	计算机及周边	www.ti.com.cn/computer
数据转换器	www.ti.com.cn/dataconverters	消费电子	www.ti.com.cn/consumer-apps
DLP® 产品	www.dlp.com	能源	www.ti.com.cn/energy
DSP - 数字信号处理器	www.ti.com.cn/dsp	工业应用	www.ti.com.cn/industrial
时钟和计时器	www.ti.com.cn/clockandtimers	医疗电子	www.ti.com.cn/medical
接口	www.ti.com.cn/interface	安防应用	www.ti.com.cn/security
逻辑	www.ti.com.cn/logic	汽车电子	www.ti.com.cn/automotive
电源管理	www.ti.com.cn/power	视频和影像	www.ti.com.cn/video
微控制器 (MCU)	www.ti.com.cn/microcontrollers		
RFID 系统	www.ti.com.cn/rfidsys		
OMAP应用处理器	www.ti.com.cn/omap		
无线连通性	www.ti.com.cn/wirelessconnectivity	德州仪器在线技术支持社区	www.deyisupport.com

Mailing Address: Texas Instruments, Post Office Box 655303, Dallas, Texas 75265
Copyright © 2015, Texas Instruments Incorporated

X-ON Electronics

Largest Supplier of Electrical and Electronic Components

Click to view similar products for [Analog Comparators](#) category:

Click to view products by [Texas Instruments](#) manufacturer:

Other Similar products are found below :

[SC2903VDR2G](#) [LM2901SNG](#) [LM339SNG](#) [55122](#) [5962-8757203IA](#) [NTE911](#) [LM339EDR2G](#) [NTE922](#) [UPC177GR-9LG-E2-A](#)
[HT393VRMZ](#) [LM2903YD](#) [NCV2200SN1T1G](#) [LM2903A-SR](#) [LM339A-SR](#) [HT339ARQZ](#) [LM2901XP](#) [LM2903DR-JSM](#) [MS8923](#)
[LM239AM/TR](#) [LM393LVQPWRQ1](#) [LM2903BWDSGRQ1](#) [TLV3801DSGT](#) [LM331BXF](#) [AD790JRZ-REEL](#) [LM339A-TR](#) [LT6700HVHS6-1#TRPBF](#) [GS2903-SR](#) [LMV7219M5/TR](#) [LMV7239M5/TR](#) [LM293ADR-HXY](#) [LM293DR-HXY](#) [LM339N-HXY](#) [LM393P-HXY](#) [IL339DT](#)
[LM2901XQ](#) [RS331XF-Q1](#) [MIC842NYMT-TR](#) [LM393FVM-TR](#) [LM393P](#) [TLV3602QDGKRQ1](#) [TLV7032QDGKRQ1](#) [TLV3601QDBVRQ1](#)
[LM2901BQPWRQ1](#) [TLV3603DCKR](#) [TLV3603DCKT](#) [AiP74HC85TA16.TB](#) [LMV331IDBVR\(MS\)](#) [LMV331TP-MS](#) [LMV331W5-7\(MS\)](#)
[MCP6561UT-E\(MS\)](#)