

TLV181x and TLV182x Family of 40 V Rail-to-Rail Input Comparators with Push-Pull or Open-Drain Output Options

1 Features

- Wide 2.4 V to 40 V supply range
- Rail-to-rail input
- Power-On Reset (POR) for known start-up
- Low input offset voltage 500 μ V
- 420ns typical propagation delay
- Low quiescent current 5 μ A per channel
- Low input bias current 150 fA
- Open-drain output option (TLV182x)
- Push-pull output option (TLV181x)
- Full -40°C to +125°C temperature range
- 2 kV ESD protection
- [Functional Safety-Capable](#)
 - [Documentation available to aid functional safety system design](#)

2 Applications

- [Appliances](#)
- [Factory automation and control](#)
- [Motor drives](#)
- [Infotainment and cluster](#)

3 Description

The TLV181x and TLV182x are a family of 40 Volt single, dual and quad channel comparators with multiple output options. The family offers rail-to-rail inputs with push-pull or open-drain output options. The family has an excellent speed-to-power combination with a propagation delay of 420 ns with a full supply voltage range of 2.4 V to 40 V with a quiescent supply current of only 5 μ A per channel.

All devices include a Power-On Reset (POR) feature. This ensures the output is in a known state until the

minimum supply voltage has been reached before the output responds to the inputs, thus preventing false outputs during system power-up and power-down.

The TLV181x comparators have a push-pull output stage capable of sinking and sourcing milliamps of current when controlling an LED or driving a capacitive load such as a MOSFET gate.

The TLV182x comparators have an open-drain output stage that can be pulled up to 40 V independent of comparator supply voltage.

Device Information

PART NUMBER	PACKAGE ⁽¹⁾	BODY SIZE (NOM)
TLV1811, TLV1821 (Single)	SC-70 (6)	1.25 mm x 2.00 mm
	SOT-23 (5)	1.60 mm x 2.90 mm
TLV1811L, TLV1821L (Single - alt pinout)	SC-70 (5)	1.25 mm x 2.00 mm
	SOT-23 (5)	1.60 mm x 2.90 mm
TLV1812, TLV1822 (Dual)	SOIC (8)	3.91 mm x 4.90 mm
	TSSOP (8) (Preview)	3.00 mm x 4.40 mm
	VSSOP (8) (Preview)	3.00 mm x 3.00 mm
	WSON (8) (Preview)	2.00 mm x 2.00 mm
	SOT-23 (8) (Preview)	1.60 mm x 2.90 mm
TLV1814, TLV1824 (Quad)	SOIC (14) (Preview)	3.91 mm x 8.65 mm
	TSSOP (14) (Preview)	4.40 mm x 5.00 mm
	SOT-23 (14) (Preview)	4.20 mm x 2.00 mm
	WQFN (16) (Preview)	3.00 mm x 3.00 mm

(1) For all available packages, see the orderable addendum at the end of the data sheet.

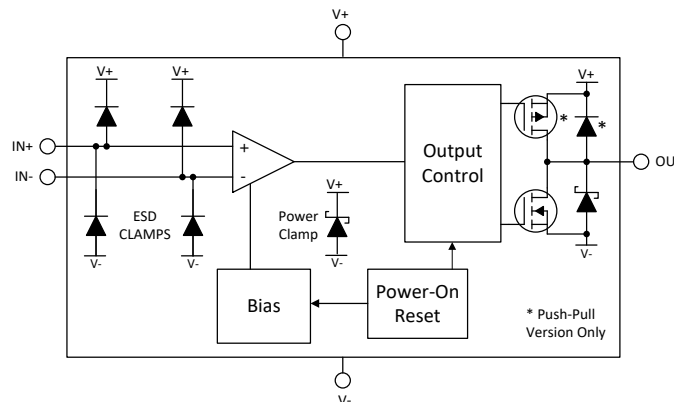

TLV18xx Block Diagram



Table of Contents

1 Features	1	8.1 Overview.....	13
2 Applications	1	8.2 Functional Block Diagrams.....	13
3 Description	1	8.3 Feature Description.....	13
4 Revision History	2	8.4 Device Functional Modes.....	13
5 Pin Configuration and Functions	3	9 Application and Implementation	16
Pin Functions: TLV18x1 and TLV18x1L.....	3	9.1 Application Information.....	16
Pin Functions: TLV1812 and TLV1822.....	4	9.2 Typical Applications.....	19
Pin Functions: TLV1814 and TLV1824.....	5	9.3 Power Supply Recommendations.....	26
6 Specifications	6	9.4 Layout.....	26
6.1 Absolute Maximum Ratings.....	6	10 Device and Documentation Support	28
6.2 ESD Ratings.....	6	10.1 Documentation Support.....	28
6.3 Recommended Operating Conditions.....	6	10.2 Receiving Notification of Documentation Updates.....	28
6.4 Thermal Information - Single.....	7	10.3 Support Resources.....	28
6.5 Thermal Information - Dual.....	7	10.4 Trademarks.....	28
6.6 Thermal Information - Quad.....	7	10.5 Electrostatic Discharge Caution.....	28
6.7 Electrical Characteristics.....	8	10.6 Glossary.....	28
6.8 Switching Characteristics.....	9	11 Mechanical, Packaging, and Orderable Information	28
7 Typical Characteristics	10		
8 Detailed Description	13		

4 Revision History

NOTE: Page numbers for previous revisions may differ from page numbers in the current version.

Changes from Revision A (November 2022) to Revision B (December 2022)	Page
• Commercial TLV1811/21 Single Release.....	1

Changes from Revision * (September 2022) to Revision A (November 2022)	Page
• Commercial TLV1812/22 Dual Release.....	1

5 Pin Configuration and Functions

Pin Functions: TLV18x1 and TLV18x1L

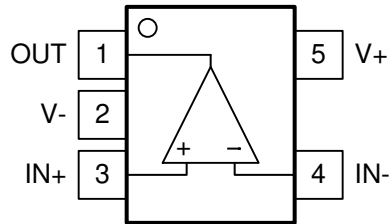

TLV1811 and TLV1821
Standard "North West" pinout
DBV, DCK Packages,
SOT-23-5, SC-70-5
Top View

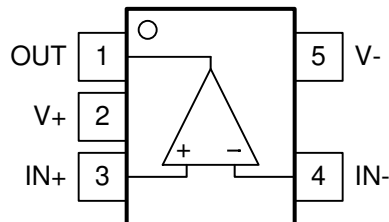

TLV1811L and TLV1821L DBV Package,
"LMC72x1/TLV72x1 type" pinout with reversed supplies
SOT-23-5,
Top View

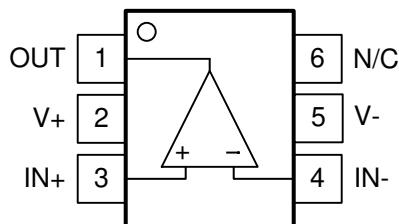

TLV1811L and TLV1821L DCK Package,
"TLV72x1 6-pin type" pinout with reversed supplies and shifted V-
SC-70-6,
Top View

Table 5-1. Pin Functions: TLV1811, TLV1821, TLV1811L and TLV1821L

NAME	TLV1811, TLV1821		TLV1811L, TLV1821L		I/O	DESCRIPTION
	PINS		PINS			
	SOT-23	SC-70	SOT-23	SC-70		
OUT	1	1	1	1	O	Output
V-	2	2	5	5	-	Negative Supply Voltage
IN+	3	3	3	3	I	Non-Inverting (+) Input
IN-	4	4	4	4	I	Inverting (-) Input
V+	5	5	2	2	-	Positive Supply Voltage
N/C	-	-	-	6	-	No Connection

Pin Functions: TLV1812 and TLV1822

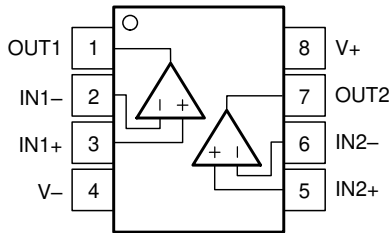

D, DGK, PW, DDF Packages
8-Pin SOIC, VSSOP, TSSOP, SOT-23-8
 Top View

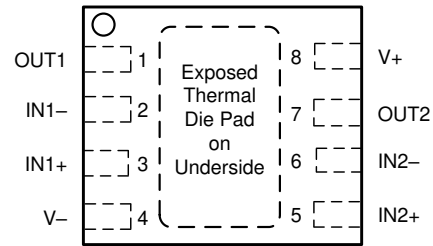

NOTE: Connect exposed thermal pad directly to V- pin.
DSG Package,
8-Pad WSON With Exposed Thermal Pad,
 Top View

Table 5-2. Pin Functions: TLV1812 and TLV1822

PIN		I/O	DESCRIPTION
NAME	NO.		
OUT1	1	O	Output pin of the comparator 1
IN1-	2	I	Inverting input pin of comparator 1
IN1+	3	I	Noninverting input pin of comparator 1
V-	4	—	Negative (low) supply
IN2+	5	I	Noninverting input pin of comparator 2
IN2-	6	I	Inverting input pin of comparator 2
OUT2	7	O	Output pin of the comparator 2
V+	8	—	Positive supply
Thermal Pad	—	—	Connect directly to V- pin

Pin Functions: TLV1814 and TLV1824

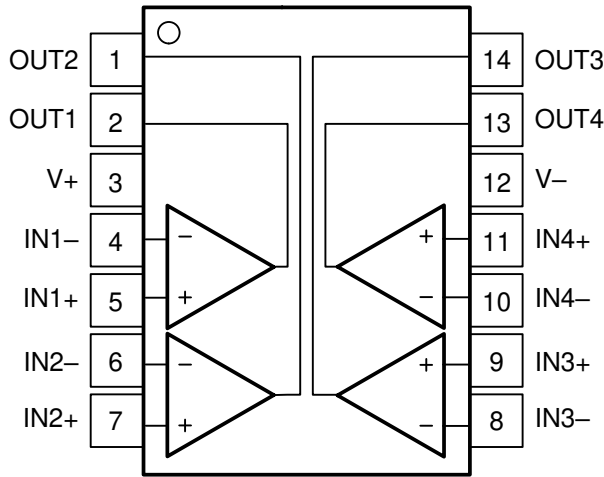

**D, PW, DYY Package, 14-Pin SOIC, TSSOP, SOT-23,
Top View**

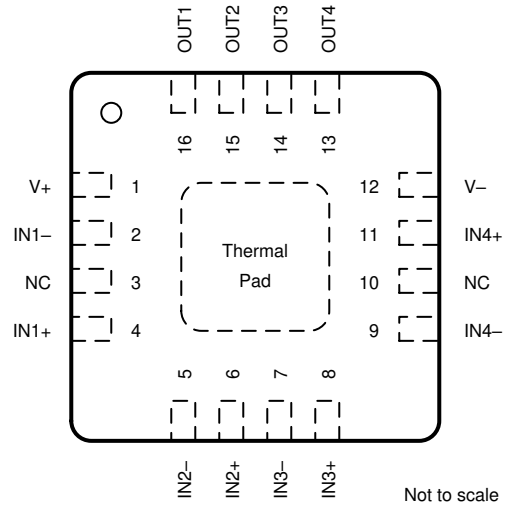

**RTE Package, 16-Pad WQFN With Exposed
Thermal Pad, Top View**
NOTE: Connect exposed thermal pad directly to V- pin.
Not to scale

Table 5-3. Pin Functions: TLV1814 and TLV1824

PIN			I/O	DESCRIPTION
NAME	SOIC	WQFN		
OUT2 ⁽¹⁾	1	15	O	Output pin of the comparator 2
OUT1 ⁽¹⁾	2	16	O	Output pin of the comparator 1
V+	3	1	—	Positive supply
IN1-	4	2	I	Negative input pin of the comparator 1
IN1+	5	4	I	Positive input pin of the comparator 1
IN2-	6	5	I	Negative input pin of the comparator 2
IN2+	7	6	I	Positive input pin of the comparator 2
IN3-	8	7	I	Negative input pin of the comparator 3
IN3+	9	8	I	Positive input pin of the comparator 3
IN4-	10	9	I	Negative input pin of the comparator 4
IN4+	11	11	I	Positive input pin of the comparator 4
V-	12	12	—	Negative supply
OUT4	13	13	O	Output pin of the comparator 4
OUT3	14	14	O	Output pin of the comparator 3
NC	—	3	—	No Internal Connection - Leave floating or GND
NC	—	10	—	No Internal Connection - Leave floating or GND
Thermal Pad	—	PAD	—	Connect directly to V- pin.

(1) Some manufacturers transpose the names of channels 1 and 2. Electrically the pinouts are identical, just a difference in channel naming convention.

6 Specifications

6.1 Absolute Maximum Ratings

over operating free-air temperature range (unless otherwise noted)⁽¹⁾

	MIN	MAX	UNIT
Supply voltage: $V_S = (V+) - (V-)$	-0.3	42	V
Input pins (IN+, IN-) from (V-), Rail-to-Rail Input ⁽²⁾	-0.3	(V+) + 0.3	V
Current into Input pins (IN+, IN-)	-10	10	mA
Output (OUT) voltage (Open-Drain) from (V-) ⁽³⁾	-0.3	42	V
Output (OUT) voltage (Push-Pull) from (V-)	-0.3	(V+) + 0.3	V
Output (OUT) current ^{(4) (5) (6)}	-10	10	mA
Junction temperature, T_J		150	°C
Storage temperature, T_{stg}	-65	150	°C

- Operation outside the Absolute Maximum Ratings may cause permanent device damage. Absolute Maximum Ratings do not imply functional operation of the device at these or any other conditions beyond those listed under Recommended Operating Conditions. If used outside the Recommended Operating Conditions but within the Absolute Maximum Ratings, the device may not be fully functional, and this may affect device reliability, functionality, performance, and shorten the device lifetime.
- Input terminals are diode-clamped to (V-). Inputs (IN+, IN-) can be greater than (V+) and OUT as long as it is within the -0.3 V to 42 V range
- Output (OUT) for open drain can be greater than (V+) and inputs (IN+, IN-) as long as it is within the -0.3 V to 42 V range
- The output is diode-clamped to (V-) for both output options, and diode clamped to (V+) for the push-pull output option. The open drain version does not have a clamp to V+. Please see the *Outputs* and *ESD Protection* section of the *Application Information* Section for more information.
- Output sinking and sourcing current is internally limited to <35mA when operating within the Absolute Maximum output voltage limits. The Absolute Maximum Output Current limit specified here is the maximum current through the clamp structure when exceeding the supply voltage below (V-) for both output options, or above (V+) for the push-pull option.
- Short-circuit from output to (V-) or (V+). Continuous output short circuits at elevated supply voltages can result in excessive heating and exceeding the maximum allowed junction temperature, leading to eventual device destruction.

6.2 ESD Ratings

		VALUE	UNIT
$V_{(ESD)}$	Electrostatic discharge	Human-body model (HBM), per ANSI/ESDA/JEDEC JS-001 ⁽¹⁾	±2000
		Charged-device model (CDM), per JEDEC specification JESD22-C101 ⁽²⁾	±500
			V

- JEDEC document JEP155 states that 500 V HBM allows safe manufacturing with a standard ESD control process.
- JEDEC document JEP157 states that 250 V CDM allows safe manufacturing with a standard ESD control process.

6.3 Recommended Operating Conditions

over operating free-air temperature range (unless otherwise noted)

	MIN	MAX	UNIT
Supply voltage: $V_S = (V+) - (V-)$	2.4	40	V
Input voltage range from (V-)	-0.2	(V+) + 0.2	V
Output voltage range from (V-)	Open Drain	-0.2	40
	Push Pull	-0.2	(V+) + 0.2
Ambient temperature, T_A	-40	125	°C

6.4 Thermal Information - Single

THERMAL METRIC ⁽¹⁾		TLV18x1 and TLV18x1L			UNIT
		DCK (SC-70)	DCK (SC-70)	DBV (SOT-23)	
		5 PINS	6 PINS	5 PINS	
R _{θJA}	Junction-to-ambient thermal resistance	226.6	185.6	203.4	°C/W
R _{θJC(top)}	Junction-to-case (top) thermal resistance	129.5	137.6	105.4	°C/W
R _{θJB}	Junction-to-board thermal resistance	78.6	76.5	106.6	°C/W
ψ _{JT}	Junction-to-top characterization parameter	51.5	59.8	54.0	°C/W
ψ _{JB}	Junction-to-board characterization parameter	78.3	76.2	106	°C/W
R _{θJC(bot)}	Junction-to-case (bottom) thermal resistance	–	–	–	°C/W

(1) For more information about traditional and new thermal metrics, see the [Semiconductor and IC Package Thermal Metrics](#) report.

6.5 Thermal Information - Dual

THERMAL METRIC ⁽¹⁾		TLV18x2					UNIT
		D (SOIC)	PW (TSSOP)	DDF (SOT-23)	DSG (WSON)	DGK (VSSOP)	
		8 PINS	8 PINS	8 PINS	8 PINS	8 PINS	
R _{θJA}	Junction-to-ambient thermal resistance	136.1					°C/W
R _{θJC(top)}	Junction-to-case (top) thermal resistance	76.8					°C/W
R _{θJB}	Junction-to-board thermal resistance	79.7					°C/W
ψ _{JT}	Junction-to-top characterization parameter	26.8					°C/W
ψ _{JB}	Junction-to-board characterization parameter	78.9					°C/W
R _{θJC(bot)}	Junction-to-case (bottom) thermal resistance	–	–	–		–	°C/W

(1) For more information about traditional and new thermal metrics, see the [Semiconductor and IC Package Thermal Metrics](#) report.

6.6 Thermal Information - Quad

THERMAL METRIC ⁽¹⁾		TLV18x4					UNIT
		D (SOIC)	PW (TSSOP)	DDF (SOT-23)	DSG (WQFN)	DGK (VSSOP)	
		14 PINS	14 PINS	14 PINS	16 PINS	16 PINS	
R _{θJA}	Junction-to-ambient thermal resistance	104.2					°C/W
R _{θJC(top)}	Junction-to-case (top) thermal resistance	60.3					°C/W
R _{θJB}	Junction-to-board thermal resistance	60.2					°C/W
ψ _{JT}	Junction-to-top characterization parameter	20.7					°C/W
ψ _{JB}	Junction-to-board characterization parameter	59.8					°C/W
R _{θJC(bot)}	Junction-to-case (bottom) thermal resistance	–	–	–		–	°C/W

(1) For more information about traditional and new thermal metrics, see the [Semiconductor and IC Package Thermal Metrics](#) report.

6.7 Electrical Characteristics

For V_S (Total Supply Voltage) = $(V+) - (V-) = 12\text{ V}$, $V_{CM} = V_S / 2$ at $T_A = 25^\circ\text{C}$ (Unless otherwise noted)

PARAMETER		TEST CONDITIONS	MIN	TYP	MAX	UNIT
OFFSET VOLTAGE						
V_{OS}	Input offset voltage		-3	±0.5	3	mV
		$T_A = -40^\circ\text{C}$ to $+125^\circ\text{C}$	-4		4	mV
dV_{IO}/dT	Input offset voltage drift	$T_A = -40^\circ\text{C}$ to $+125^\circ\text{C}$		±1.2		$\mu\text{V}/^\circ\text{C}$
PSRR	Power supply rejection ratio	$V_S = 2.4\text{ V}$ to 40 V , $V_{CM} = (V-)$		100		dB
POWER SUPPLY						
I_Q	Quiescent current, No Load	Output Low, $T_A = 25^\circ\text{C}$ TLV1811 Only		6	7.5	μA
		Output Low, $T_A = -40^\circ\text{C}$ to $+125^\circ\text{C}$ TLV1811 Only			8.5	
		Output High, $T_A = 25^\circ\text{C}$ TLV1811 Only		8	10	
		Output High, $T_A = -40^\circ\text{C}$ to $+125^\circ\text{C}$ TLV1811 Only			11	
I_Q	Quiescent current per comparator, No Load	Output Low, $T_A = 25^\circ\text{C}$		5	6.5	μA
		Output Low, $T_A = -40^\circ\text{C}$ to $+125^\circ\text{C}$			7.5	
		Output High, $T_A = 25^\circ\text{C}$		7	9	
		Output High, $T_A = -40^\circ\text{C}$ to $+125^\circ\text{C}$			10	
V_{POR}	Power On Reset Voltage			1.7		V
INPUT BIAS CURRENT						
I_B	Input bias current ⁽¹⁾			150		fA
		$T_A = -40^\circ\text{C}$ to $+125^\circ\text{C}$	-1.2		1.2	nA
I_{OS}	Input offset current ⁽¹⁾			10		fA
INPUT CAPACITANCE						
C_{ID}	Input Capacitance, Differential			2		pF
C_{IC}	Input Capacitance, Common Mode			8		pF
INPUT COMMON MODE RANGE						
$V_{CM\text{-Range}}$	Common-mode voltage range	$V_S = 2.4\text{ V}$ to 40 V $T_A = -40^\circ\text{C}$ to $+125^\circ\text{C}$, Rail to Rail	$(V-) - 0.2$		$(V+) + 0.2$	V
OUTPUT						
V_{OL}	Voltage swing from $(V-)$	$I_{SINK} = 4\text{ mA}$ $T_A = -40^\circ\text{C}$ to $+125^\circ\text{C}$			250	mV
V_{OH}	Voltage swing from $(V+)$ (for Push-Pull only)	$I_{SOURCE} = 4\text{ mA}$ $T_A = -40^\circ\text{C}$ to $+125^\circ\text{C}$			250	mV
I_{LKG}	Open-drain output leakage current	$V_{ID} = +0.1\text{ V}$, $V_{PULLUP} = (V+)$ $T_A = -40^\circ\text{C}$ to $+125^\circ\text{C}$		0.1		nA
I_{OL}	Short-circuit current	Sinking	15	30		mA
I_{OH}	Short-circuit current	Sourcing (for Push-Pull only)	15	30		mA

(1) This parameter is ensured by design and/or characterization and is not tested in production .

6.8 Switching Characteristics

For V_S (Total Supply Voltage) = $(V+) - (V-) = 12\text{ V}$, $V_{CM} = V_S / 2$ at $T_A = 25^\circ\text{C}$ (Unless otherwise noted)

PARAMETER		TEST CONDITIONS	MIN	TYP	MAX	UNIT
OUTPUT						
T_{PD-HL}	Propagation delay time, high-to-low	$V_{OD} = 10\text{ mV}$, $C_L = 50\text{ pF}$		900		ns
T_{PD-HL}	Propagation delay time, high-to-low	$V_{OD} = 100\text{ mV}$, $C_L = 50\text{ pF}$		450		ns
T_{PD-LH}	Propagation delay time, low-to-high, push-pull output	$V_{OD} = 10\text{ mV}$, $C_L = 50\text{ pF}$		900		ns
T_{PD-LH}	Propagation delay time, low-to-high, push-pull output	$V_{OD} = 100\text{ mV}$, $C_L = 50\text{ pF}$		420		ns
T_{RISE}	Output Rise Time, 20% to 80%, push-pull output	$C_L = 50\text{ pF}$		15		ns
T_{FALL}	Output Fall Time, 80% to 20%	$C_L = 50\text{ pF}$		15		ns
F_{TOGGLE}	Toggle Frequency	$V_{ID} = 100\text{ mV}$, $C_L = 50\text{ pF}$		500		kHz
POWER ON TIME						
P_{ON}	Power on-time			200		μs

7 Typical Characteristics

$T_A = 25^\circ\text{C}$, $V_S = 12\text{ V}$, $R_{\text{PULLUP}} = 2.5\text{ k}$, $C_L = 20\text{ pF}$, $V_{\text{CM}} = 0\text{ V}$, $V_{\text{UNDERDRIVE}} = 100\text{ mV}$, $V_{\text{OVERDRIVE}} = 100\text{ mV}$ unless otherwise noted.

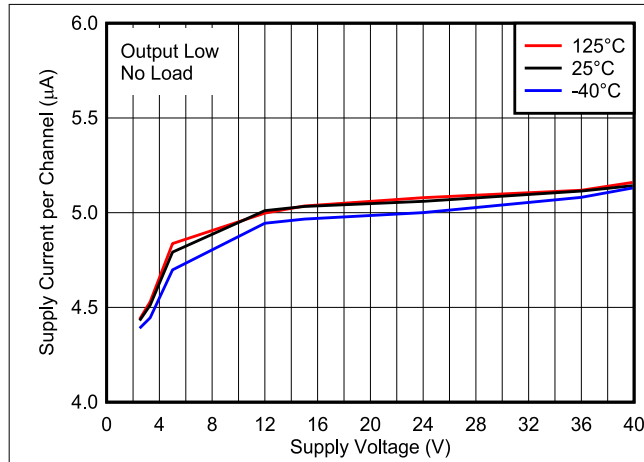

Figure 7-1. Supply Current per Channel vs. Supply Voltage, Output Low

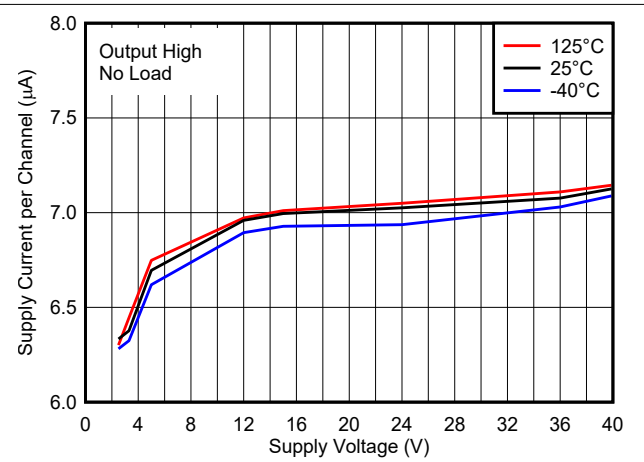

Figure 7-2. Supply Current per Channel vs. Supply Voltage, Output High

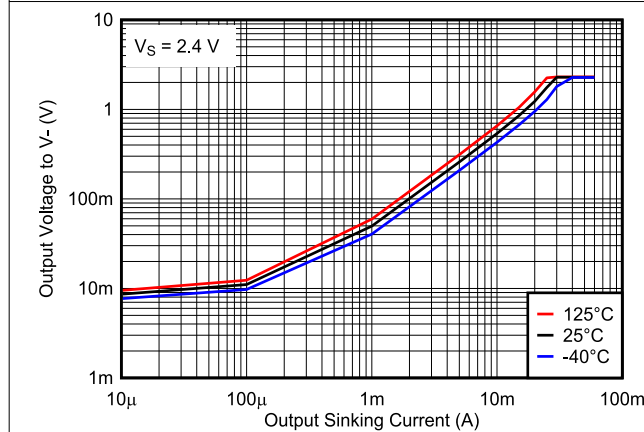

Figure 7-3. Output Voltage vs. Output Sinking Current, 2.4 V

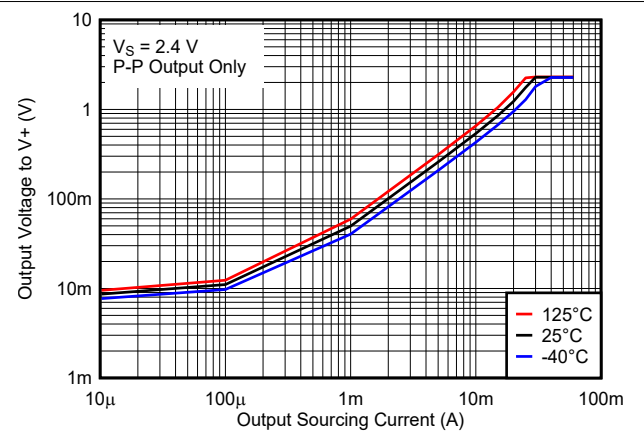

Figure 7-4. Output Voltage vs. Output Sourcing Current, 2.4 V

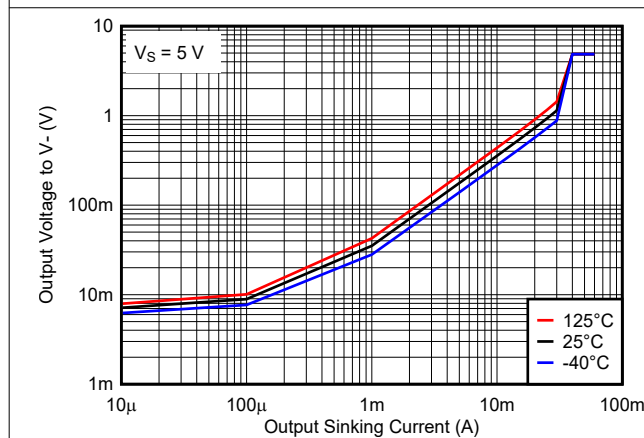

Figure 7-5. Output Voltage vs. Output Sinking Current, 5 V

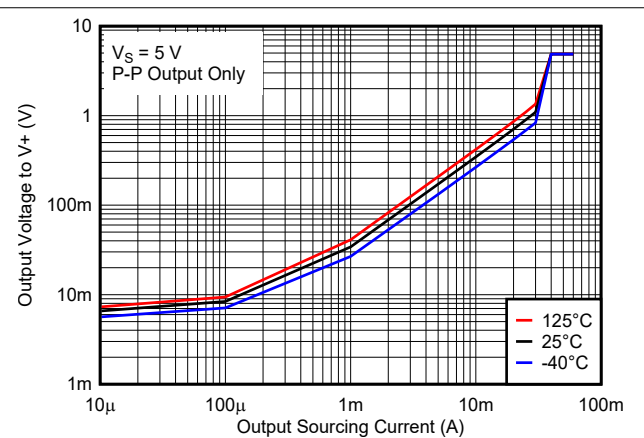

Figure 7-6. Output Voltage vs. Output Sourcing Current, 5 V

7 Typical Characteristics (continued)

$T_A = 25^\circ\text{C}$, $V_S = 12\text{ V}$, $R_{\text{PULLUP}} = 2.5\text{ k}$, $C_L = 20\text{ pF}$, $V_{\text{CM}} = 0\text{ V}$, $V_{\text{UNDERDRIVE}} = 100\text{ mV}$, $V_{\text{OVERDRIVE}} = 100\text{ mV}$ unless otherwise noted.

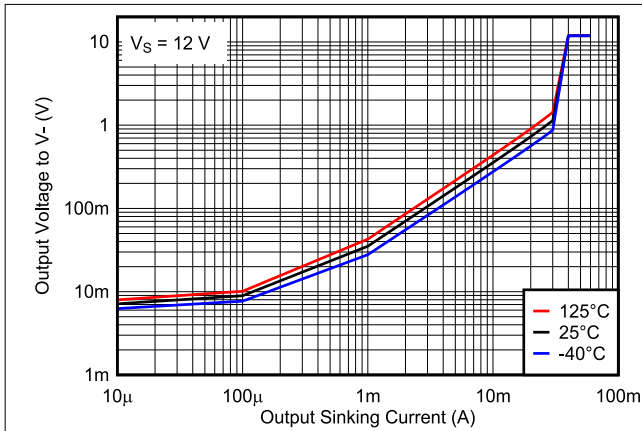

Figure 7-7. Output Voltage vs. Output Sinking Current, 12 V

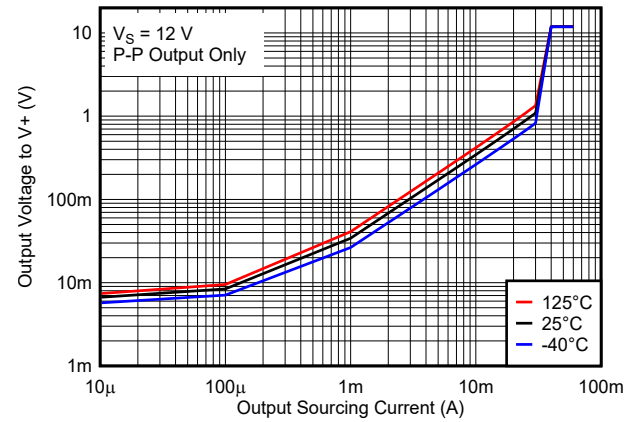

Figure 7-8. Output Voltage vs. Output Sourcing Current, 12 V

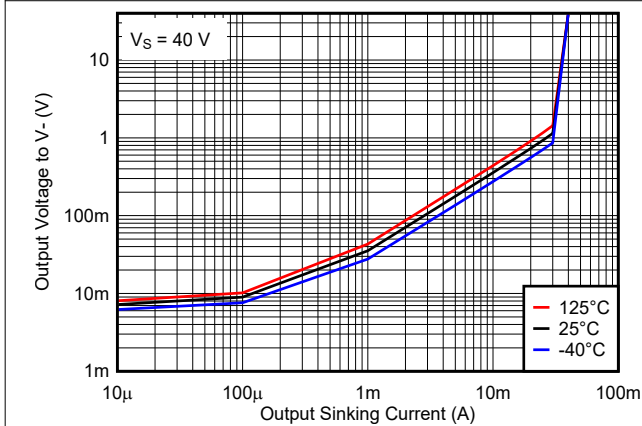

Figure 7-9. Output Voltage vs. Output Sinking Current, 40 V

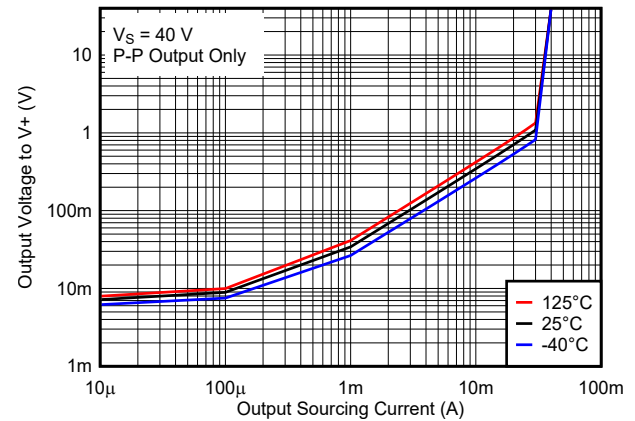

Figure 7-10. Output Voltage vs. Output Sourcing Current, 40 V

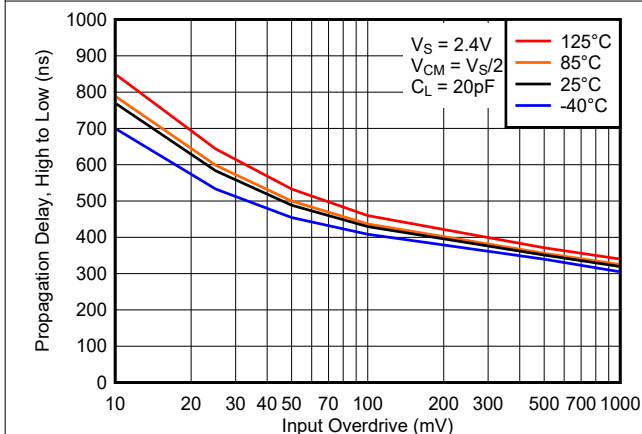

Figure 7-11. Propagation Delay, High to Low, 2.4V

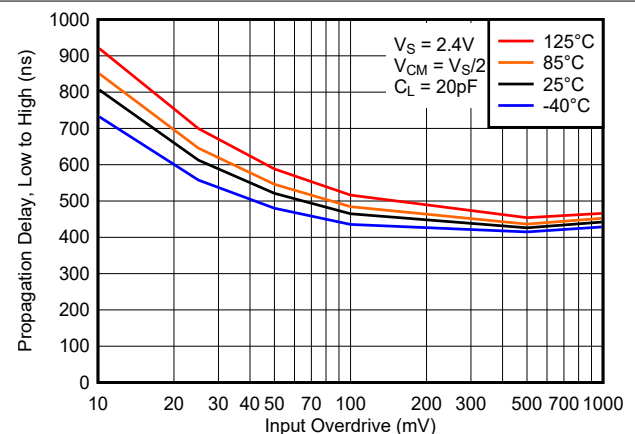

Figure 7-12. Propagation Delay, Low to High, 2.4V

7 Typical Characteristics (continued)

$T_A = 25^\circ\text{C}$, $V_S = 12\text{ V}$, $R_{\text{PULLUP}} = 2.5\text{ k}$, $C_L = 20\text{ pF}$, $V_{\text{CM}} = 0\text{ V}$, $V_{\text{UNDERDRIVE}} = 100\text{ mV}$, $V_{\text{OVERDRIVE}} = 100\text{ mV}$ unless otherwise noted.

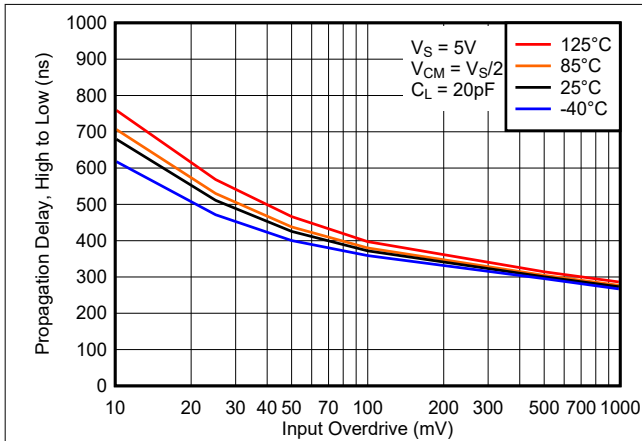

Figure 7-13. Propagation Delay, High to Low, 5V

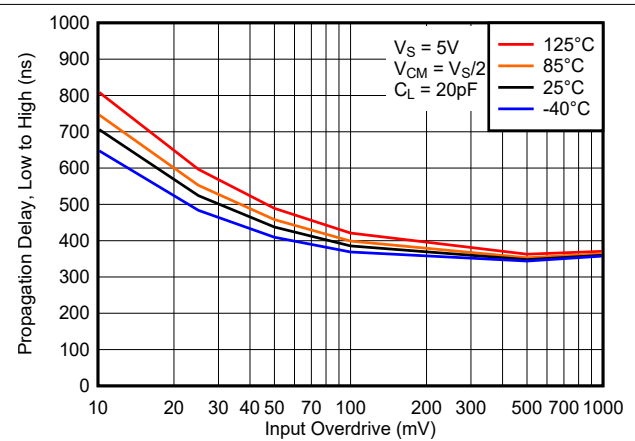

Figure 7-14. Propagation Delay, Low to High, 5V

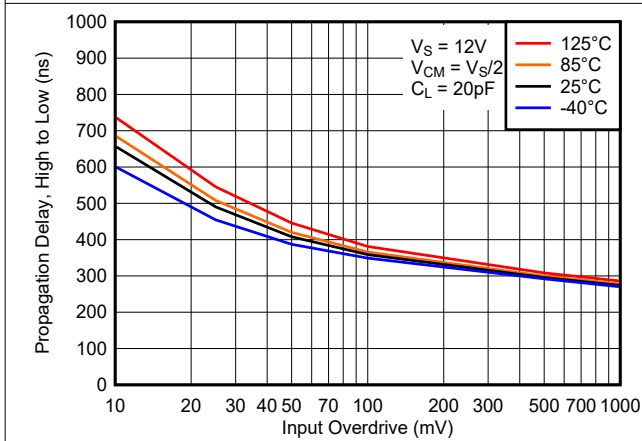

Figure 7-15. Propagation Delay, High to Low, 12V

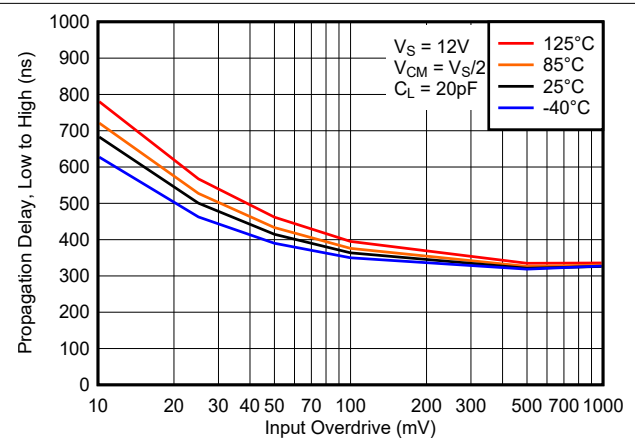

Figure 7-16. Propagation Delay, Low to High, 12V

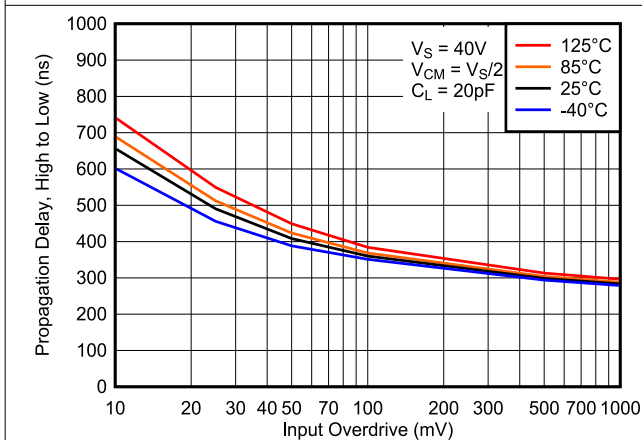

Figure 7-17. Propagation Delay, High to Low, 40V

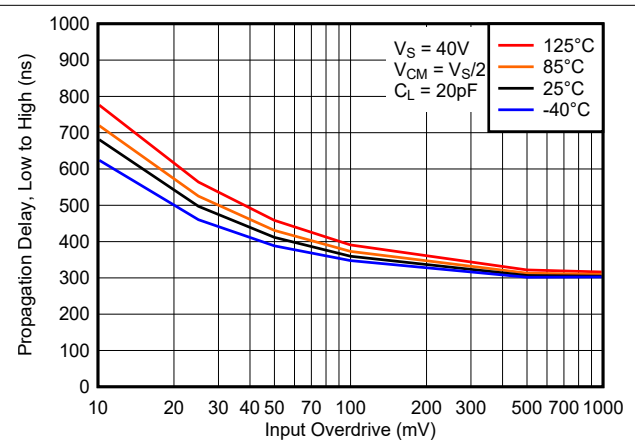

Figure 7-18. Propagation Delay, Low to High, 40V

8 Detailed Description

8.1 Overview

The TLV181x and TLV182x devices are micro-power comparators with push-pull and open-drain output options. Operating down to 2.4 V while only consuming only 5 μ A per channel, the TLV181x and TLV182x are well suited for portable, automotive and industrial applications. An internal power-on reset circuit ensures that the output remains in a known state during power-up and power-down.

8.2 Functional Block Diagrams

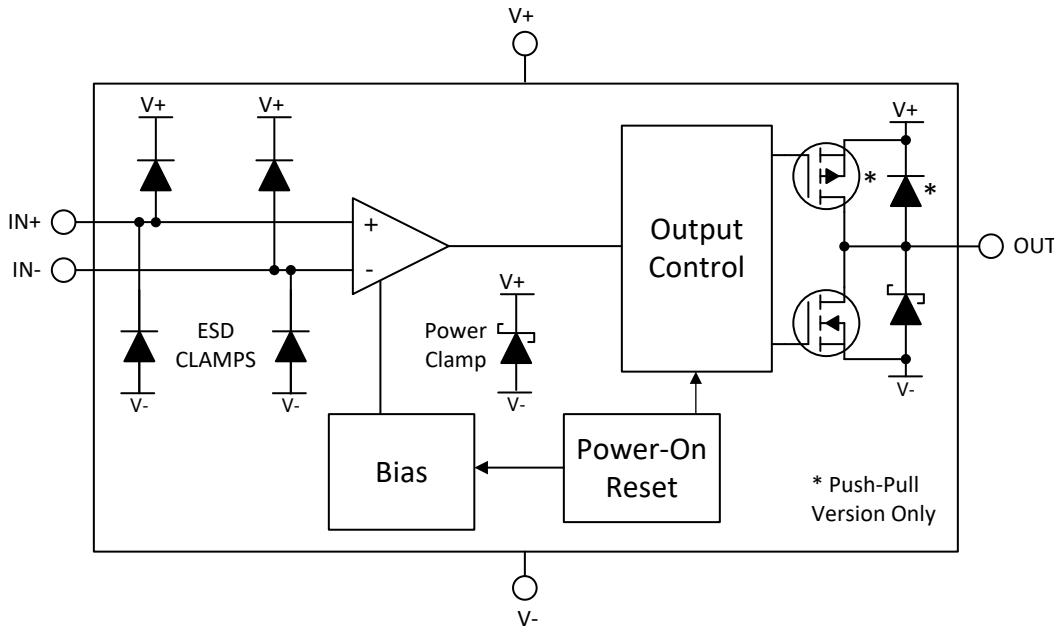

Figure 8-1. TLV18xx Block Diagram

8.3 Feature Description

TLV18xx Family Options

The TLV18xx family consists of several output and pinout options, all featuring 40 V operation, micro-power 5 μ A supply currents, 420 ns propagation delay, and a Power-On Reset (POR) function.

The TLV18xx family has two output options:

The TLV181x has a **push-pull** (sink-source) output.

The TLV182x has a **open-drain** (sink only) output, capable of being pulled-up to any voltage up to 40 V, independent of comparator supply voltage.

The TLV1811L and TLV1821L are alternate pinouts of the TLV1811 and TLV1821 that allow upgrading older devices such as the TLV7211, TLV7221, LMC7211 and LMC7221 family.

8.4 Device Functional Modes

8.4.1 Inputs

8.4.1.1 TLV18xx Rail-to-Rail Input

The TLV18xx input voltage range extends from 200 mV below V_- to 200 mV above V_+ . The differential input voltage (V_{ID}) may be any voltage within these limits. No phase-inversion of the comparator output will occur when the input voltages stay within the specified range.

The Rail-to-Rail input does have an ESD clamp to the V+ supply line and therefore the input voltage must not exceed the supply voltages by more than 200mV. It is not recommended to apply signals to the rail to rail inputs with no supply voltage.

8.4.1.2 ESD Protection

The TLV181x open-drain output ESD protection consists of a snapback ESD clamp between the output and V- to allow the output to be pulled above V+ to a maximum of 40 V. There is no "upper" ESD clamp diode between the output and V+ on the open-drain output. There is a "lower" clamp between V- and the output.

The TLV182x push-pull output ESD protection contains a conventional diode-type "upper" ESD clamp between the output and V+, and a "lower" ESD clamp between the output and V-. The output must not exceed the supply rails by more than 200mV.

If the inputs are to be connected to a low impedance source, such as a power supply or buffered reference line, TI recommends adding a current-limiting resistor in series with the input to limit any currents when the clamps conduct. The current must be limited 10 mA or less, though TI recommends limiting the current to 1mA or less. This series resistance may be part of any resistive input dividers or networks.

8.4.1.3 Unused Inputs

If a channel is not to be used, DO NOT tie the inputs together. Due to the high equivalent bandwidth and low offset voltage, tying the inputs directly together may cause high frequency chatter as the device triggers on its own internal wideband noise. Instead, the inputs must be tied to any available voltage that resides within the specified input voltage range and provides a minimum of 50 mV differential voltage. For example, one input can be grounded and the other input connected to a reference voltage, or even V+ (as long as the input is directly connected to the V+ pin to avoid transients).

8.4.2 Outputs

8.4.2.1 TLV181x Push-Pull Output

The TLV181x features a push-pull output stage capable of both sinking and sourcing current. This allows driving loads such as LED's and MOSFET gates, as well as eliminating the need for a power-wasting external pull-up resistor. The push-pull output must never be connected to another output.

Directly shorting the output to the opposite supply rail (V+ when output "low" or V- when output "High") can result in thermal runaway and eventual device destruction at high (>12 V) supply voltages. If output shorts are possible, a series current limiting resistor is recommended to limit the power dissipation.

Unused push-pull outputs must be left floating, and never tied to a supply, ground, or another output.

8.4.2.2 TLV182x Open-Drain Output

The TLV182x features an open-drain (also commonly called open collector) sinking-only output stage enabling the output logic levels to be pulled up to an external voltage from 0 V up to 40 V, independent of the comparator supply voltage (V+). The open-drain output allows logical OR'ing of multiple open drain outputs and logic level translation. TI recommends setting the pull-up resistor current to between 100uA and 1mA. Lower value pull-up resistor values will help increase the rising edge rise-time, but at the expense of increasing V_{OL} and higher power dissipation. The rise-time is dependent on the time constant of the total pull-up resistance and total load capacitance. Large value pull-up resistors (>1 M Ω) will create an exponential rising edge due to the output RC time constant and increase the rise-time.

Directly shorting the output to V+ can result in thermal runaway and eventual device destruction at high (>12 V) pull-up voltages. If output shorts are possible, a series current limiting resistor is recommended to limit the power dissipation.

Unused open drain outputs may be left floating, or may be tied to the V- pin if floating pins are not desired.

8.4.3 Power-On Reset (POR)

The TLV18xx family has an internal Power-on-Reset (POR) circuit for known start-up or power-down conditions. While the power supply (V+) is ramping up or ramping down, the POR circuitry will be activated for up to 200 μ s after the minimum supply voltage threshold of 2.4 V is crossed, or immediately when the supply voltage drops

below 2.4 V. When the supply voltage is equal to or greater than the minimum supply voltage, and after the delay period, the comparator output reflects the state of the differential input (V_{ID}).

For the TLV181x push-pull output devices, the output is held low during the POR period (t_{on}).

For the TLV182x open drain output option the POR circuit will keep the output high impedance (Hi-Z) during the POR period (t_{on}).

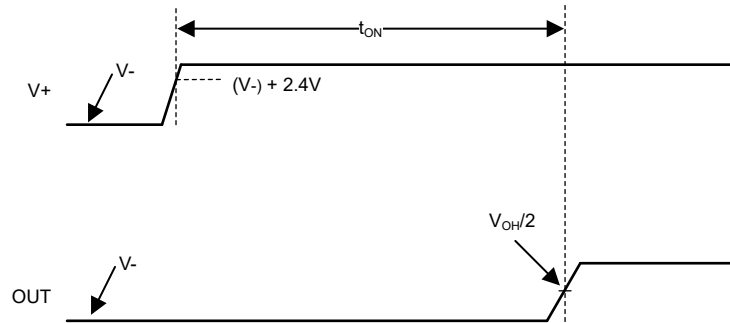

Figure 8-2. Power-On Reset Timing Diagram

Note that it the nature of an open collector output that the output will rise with the pull-up voltage during the POR period.

8.4.4 Hysteresis

The TLV18xx family does not have internal hysteresis. Due to the wide effective bandwidth and low input offset voltage, it is possible for the output to "chatter" when the absolute differential voltage is near zero as the comparator triggers on it's own internal wideband noise. This is normal comparator behavior and is expected. TI recommends that the user add external hysteresis if slow moving signals are expected. See [Section 9.1.2](#) in the following section.

9 Application and Implementation

Note

Information in the following applications sections is not part of the TI component specification, and TI does not warrant its accuracy or completeness. TI's customers are responsible for determining suitability of components for their purposes. Customers should validate and test their design implementation to confirm system functionality.

9.1 Application Information

9.1.1 Basic Comparator Definitions

9.1.1.1 Operation

The basic comparator compares the input voltage (V_{IN}) on one input to a reference voltage (V_{REF}) on the other input. In the [Figure 9-1](#) example below, if V_{IN} is less than V_{REF} , the output voltage (V_O) is logic low (V_{OL}). If V_{IN} is greater than V_{REF} , the output voltage (V_O) is at logic high (V_{OH}). [Table 9-1](#) summarizes the output conditions. The output logic can be inverted by simply swapping the input pins.

Table 9-1. Output Conditions

Inputs Condition	Output
$IN+ > IN-$	HIGH (V_{OH})
$IN+ = IN-$	Indeterminate (chatters - see Hysteresis)
$IN+ < IN-$	LOW (V_{OL})

9.1.1.2 Propagation Delay

There is a delay between from when the input crosses the reference voltage and the output responds. This is called the Propagation Delay. Propagation delay can be different between high-to-low and low-to-high input transitions. This is shown as t_{pLH} and t_{pHL} in [Figure 9-1](#) and is measured from the mid-point of the input to the midpoint of the output.

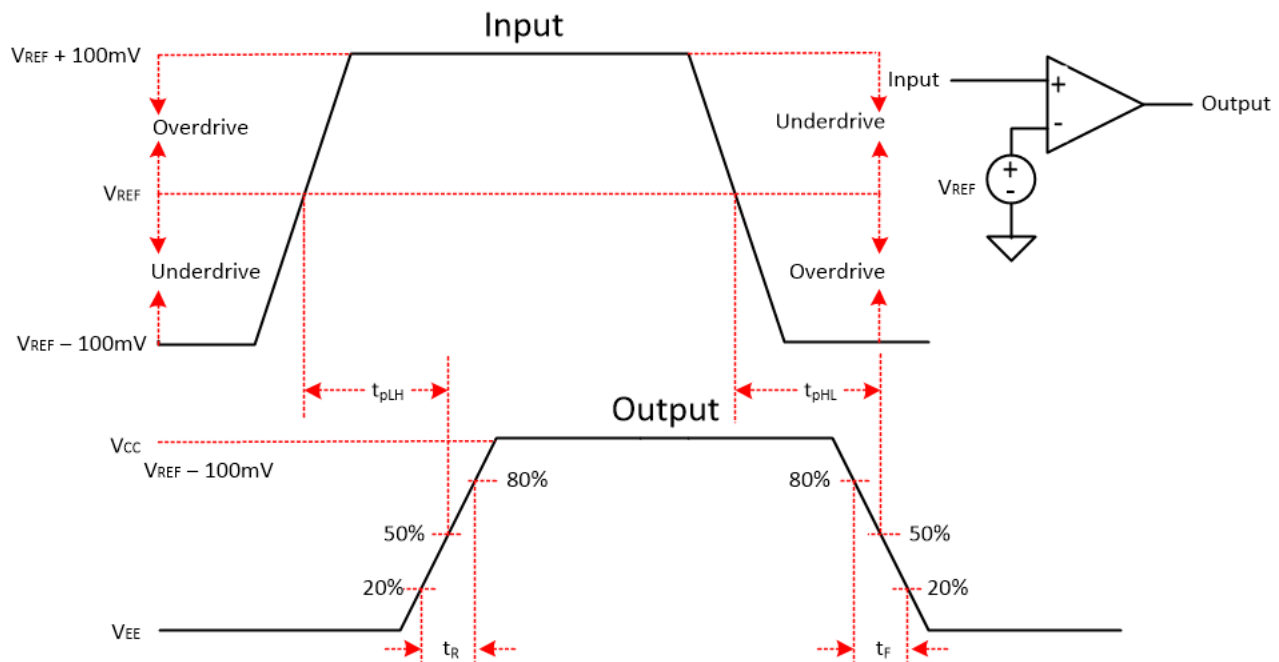

Figure 9-1. Comparator Timing Diagram

9.1.1.3 Overdrive Voltage

The overdrive voltage, V_{OD} , is the amount of input voltage beyond the reference voltage (and not the total input peak-to-peak voltage). The overdrive voltage is 100 mV as shown in the [Figure 9-1](#) example. The overdrive voltage can influence the propagation delay (t_p). The smaller the overdrive voltage, the longer the propagation delay, particularly when $<100\text{mV}$. If the fastest speeds are desired, it is recommended to apply the highest amount of overdrive possible.

The risetime (t_r) and falltime (t_f) is the time from the 20% and 80% points of the output waveform.

9.1.2 Hysteresis

The basic comparator configuration may oscillate or produce a noisy "chatter" output if the applied differential input voltage is near the comparator's offset voltage. This usually occurs when the input signal is moving very slowly across the switching threshold of the comparator.

This problem can be prevented by the addition of hysteresis or positive feedback.

The hysteresis transfer curve is shown in [Figure 9-2](#). This curve is a function of three components: V_{TH} , V_{OS} , and V_{HYST} :

- V_{TH} is the actual set voltage or threshold trip voltage.
- V_{OS} is the internal offset voltage between V_{IN+} and V_{IN-} . This voltage is added to V_{TH} to form the actual trip point at which the comparator must respond to change output states.
- V_{HYST} is the hysteresis (or trip window) that is designed to reduce comparator sensitivity to noise.

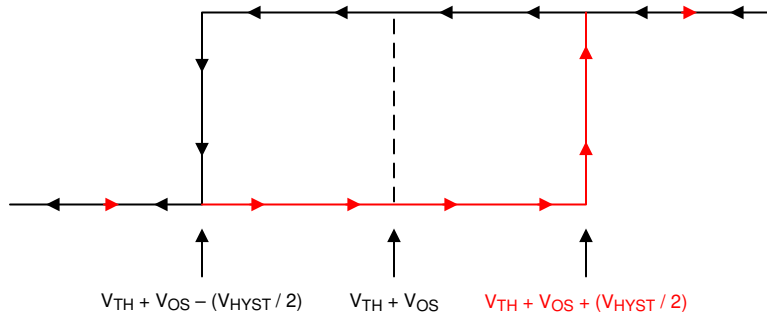

Figure 9-2. Hysteresis Transfer Curve

For more information, please see Application Note SBOA219 "[Comparator with and without hysteresis circuit](#)".

9.1.2.1 Inverting Comparator With Hysteresis

The inverting comparator with hysteresis requires a three-resistor network that is referenced to the comparator supply voltage (V_{CC}), as shown in [Figure 9-3](#).

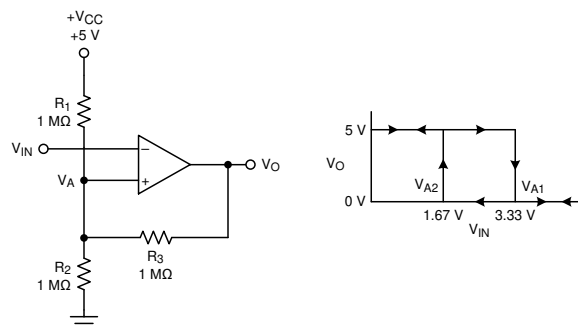

Figure 9-3. TLV181xin an Inverting Configuration With Hysteresis

The equivalent resistor networks when the output is high and low are shown in [Figure 9-3](#).

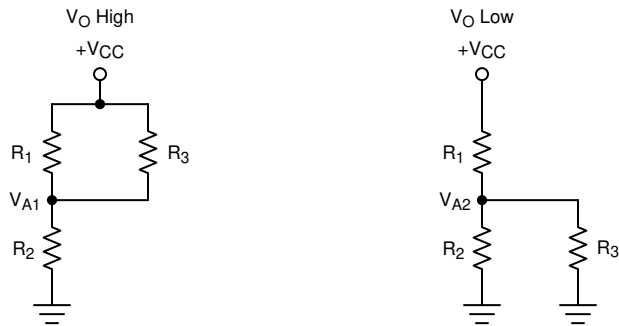

Figure 9-4. Inverting Configuration Resistor Equivalent Networks

When V_{IN} is less than V_A , the output voltage is high (for simplicity, assume V_O switches as high as V_{CC}). The three network resistors can be represented as $R1 \parallel R3$ in series with $R2$, as shown in [Figure 9-4](#).

[Equation 1](#) below defines the high-to-low trip voltage (V_{A1}).

$$V_{A1} = V_{CC} \times \frac{R2}{(R1 \parallel R3) + R2} \quad (1)$$

When V_{IN} is greater than V_A , the output voltage is low. In this case, the three network resistors can be presented as $R2 \parallel R3$ in series with $R1$, as shown in [Equation 2](#).

Use [Equation 2](#) to define the low to high trip voltage (V_{A2}).

$$V_{A2} = V_{CC} \times \frac{R2 \parallel R3}{R1 + (R2 \parallel R3)} \quad (2)$$

[Equation 3](#) defines the total hysteresis provided by the network.

$$\Delta V_A = V_{A1} - V_{A2} \quad (3)$$

9.1.2.2 Non-Inverting Comparator With Hysteresis

A non-inverting comparator with hysteresis requires a two-resistor network and a voltage reference (V_{REF}) at the inverting input, as shown in [Figure 9-5](#),

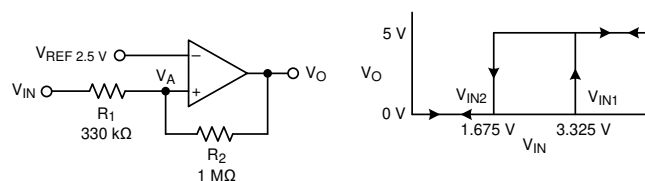

Figure 9-5. TLV181x in a Non-Inverting Configuration With Hysteresis

The equivalent resistor networks when the output is high and low are shown in [Figure 9-6](#).

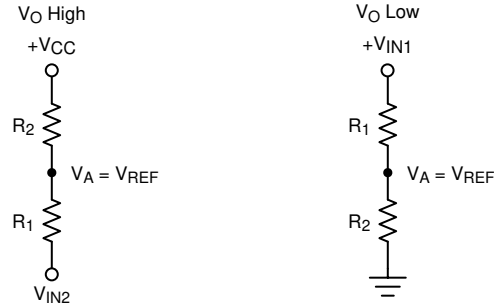

Figure 9-6. Non-Inverting Configuration Resistor Networks

When V_{IN} is less than V_{REF} , the output is low. For the output to switch from low to high, V_{IN} must rise above the V_{IN1} threshold. Use [Equation 4](#) to calculate V_{IN1} .

$$V_{IN1} = R1 \times \frac{V_{REF}}{R2} + V_{REF} \quad (4)$$

When V_{IN} is greater than V_{REF} , the output is high. For the comparator to switch back to a low state, V_{IN} must drop below V_{IN2} . Use [Equation 5](#) to calculate V_{IN2} .

$$V_{IN2} = \frac{V_{REF} (R1 + R2) - V_{CC} \times R1}{R2} \quad (5)$$

The hysteresis of this circuit is the difference between V_{IN1} and V_{IN2} , as shown in [Equation 6](#).

$$\Delta V_{IN} = V_{CC} \times \frac{R1}{R2} \quad (6)$$

For more information, please see Application Notes SNOA997 "[Inverting comparator with hysteresis circuit](#)" and SBOA313 "[Non-Inverting Comparator With Hysteresis Circuit](#)".

9.1.2.3 Inverting and Non-Inverting Hysteresis using Open-Drain Output

It is also possible to use an open drain output device, such as the TLV182x, but the output pull-up resistor must also be taken into account in the calculations. The pull-up resistor is seen in series with the feedback resistor when the output is high. Thus, the feedback resistor is actually seen as $R2 + R_{PULLUP}$. TI recommends that the pull-up resistor be at least 10 times less than the feedback resistor value.

9.2 Typical Applications

9.2.1 Window Comparator

Window comparators are commonly used to detect undervoltage and overvoltage conditions. [Figure 9-7](#) shows a simple window comparator circuit. Window comparators require open drain outputs (TLV182x) if the outputs are directly connected together.

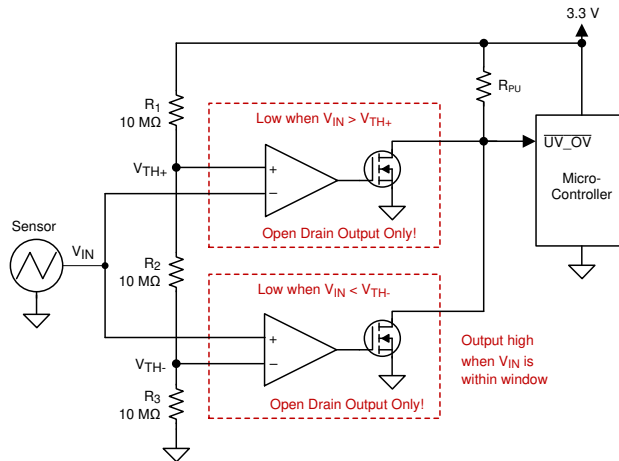

Figure 9-7. Window Comparator

9.2.1.1 Design Requirements

For this design, follow these design requirements:

- Alert (logic low output) when an input signal is less than 1.1 V
- Alert (logic low output) when an input signal is greater than 2.2 V
- Alert signal is active low
- Operate from a 3.3-V power supply

9.2.1.2 Detailed Design Procedure

Configure the circuit as shown in [Figure 9-7](#). Connect V_{CC} to a 3.3-V power supply and V_{EE} to ground. Make R1, R2 and R3 each 10-M Ω resistors. These three resistors are used to create the positive and negative thresholds for the window comparator (V_{TH+} and V_{TH-}).

With each resistor being equal, V_{TH+} is 2.2 V and V_{TH-} is 1.1 V. Large resistor values such as 10-M Ω are used to minimize power consumption. The resistor values may be recalculated to provide the desired trip point values.

The sensor output voltage is applied to the inverting and noninverting inputs of the two comparators. Using two open-drain output comparators allows the two comparator outputs to be Wire-OR'ed together.

The respective comparator outputs will be low when the sensor is less than 1.1 V or greater than 2.2 V. The respective comparator outputs will be high when the sensor is in the range of 1.1 V to 2.2 V (within the "window"), as shown in [Figure 9-8](#).

9.2.1.3 Application Curve

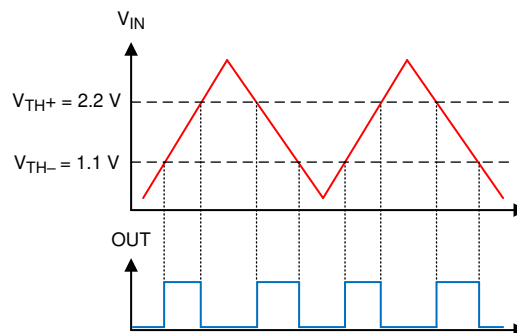

Figure 9-8. Window Comparator Results

For more information, please see Application note SBOA221 "[Window comparator circuit](#)".

9.2.2 Square-Wave Oscillator

Square-wave oscillator can be used as low cost timing reference or system supervisory clock source. A push-pull output (TLV181x) is recommended for best symmetry.

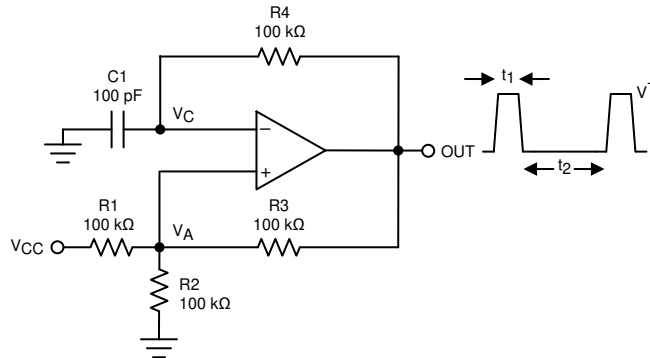

Figure 9-9. Square-Wave Oscillator

9.2.2.1 Design Requirements

The square-wave period is determined by the RC time constant of the capacitor C_1 and resistor R_4 . The maximum frequency is limited by propagation delay of the device and the capacitance load at the output. The low input bias current allows a lower capacitor value and larger resistor value combination for a given oscillator frequency, which may help to reduce BOM cost and board space. TI recommends that R_4 be over several kilo-ohms to minimize loading of the output.

9.2.2.2 Detailed Design Procedure

The oscillation frequency is determined by the resistor and capacitor values. The following calculation provides details of the steps.

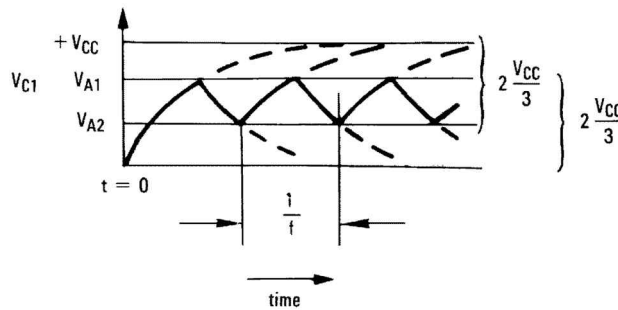

Figure 9-10. Square-Wave Oscillator Timing Thresholds

First consider the output of Figure [Figure 9-9](#) as high, which indicates the inverted input V_C is lower than the noninverting input (V_A). This causes the C_1 to be charged through R_4 , and the voltage V_C increases until it is equal to the noninverting input. The value of V_A at the point is calculated by [Equation 7](#).

$$V_{A1} = \frac{V_{CC} \times R_2}{R_2 + R_1 + R_3} \quad (7)$$

if $R_1 = R_2 = R_3$, then $V_{A1} = 2 V_{CC} / 3$

At this time the comparator output trips pulling down the output to the negative rail. The value of V_A at this point is calculated by [Equation 8](#).

$$V_{A2} = \frac{V_{CC}(R_2 \parallel R_3)}{R_1 + R_2 \parallel R_3} \quad (8)$$

if $R_1 = R_2 = R_3$, then $V_{A2} = V_{CC}/3$

The C_1 now discharges through the R_4 , and the voltage V_{CC} decreases until it reaches V_{A2} . At this point, the output switches back to the starting state. The oscillation period equals to the time duration from for C_1 from $2V_{CC}/3$ to $V_{CC} / 3$ then back to $2V_{CC}/3$, which is given by $R_4 C_1 \times \ln 2$ for each trip. Therefore, the total time duration is calculated as $2 R_4 C_1 \times \ln 2$.

The oscillation frequency can be obtained by [Equation 9](#):

$$f = 1 / (2 R_4 \times C_1 \times \ln 2) \quad (9)$$

9.2.2.3 Application Curve

[Figure 9-11](#) shows the simulated results of an oscillator using the following component values:

- $R_1 = R_2 = R_3 = R_4 = 100 \text{ k}\Omega$
- $C_1 = 100 \text{ pF}$, $C_L = 20 \text{ pF}$
- $V_+ = 5 \text{ V}$, $V_- = \text{GND}$
- C_{stray} (not shown) from V_A TO GND = 10 pF

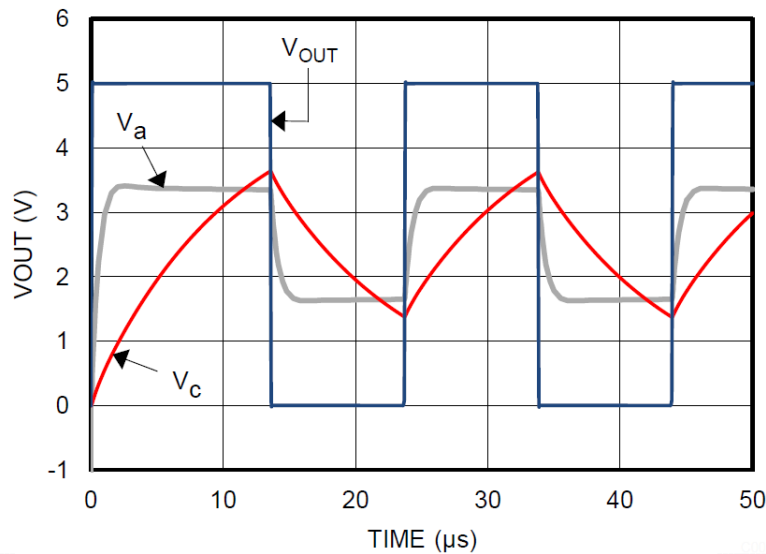

Figure 9-11. Square-Wave Oscillator Output Waveform

9.2.3 Adjustable Pulse Width Generator

[Figure 9-12](#) is a variation on the [square wave oscillator](#) that allows adjusting the pulse widths.

R_4 and R_5 provide separate charge and discharge paths for the capacitor C depending on the output state.

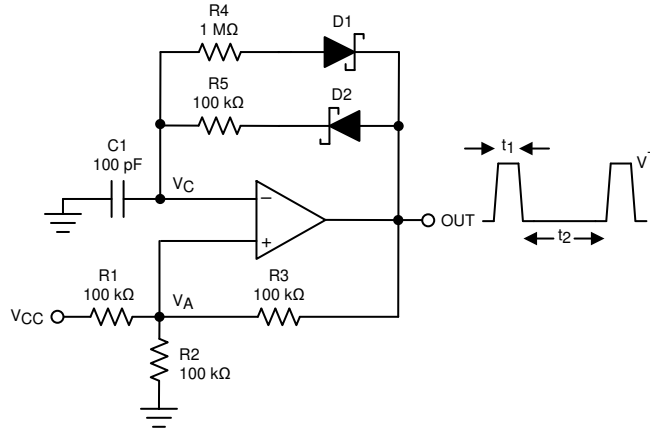

Figure 9-12. Adjustable Pulse Width Generator

The charge path is set through R_5 and D_2 when the output is high. Similarly, the discharge path for the capacitor is set by R_4 and D_1 when the output is low.

The pulse width t_1 is determined by the RC time constant of R_5 and C . Thus, the time t_2 between the pulses can be changed by varying R_4 , and the pulse width can be altered by R_5 . The frequency of the output can be changed by varying both R_4 and R_5 . At low voltages, the effects of the diode forward drop (0.8 V, or 0.15 V for Schottky) must be taken into account by altering output high and low voltages in the calculations.

9.2.4 Time Delay Generator

The circuit shown in Figure 9-13 provides output signals at a prescribed time interval from a time reference and automatically resets the output low when the input returns to 0 V. This is useful for sequencing a "power on" signal to trigger a controlled start-up of power supplies.

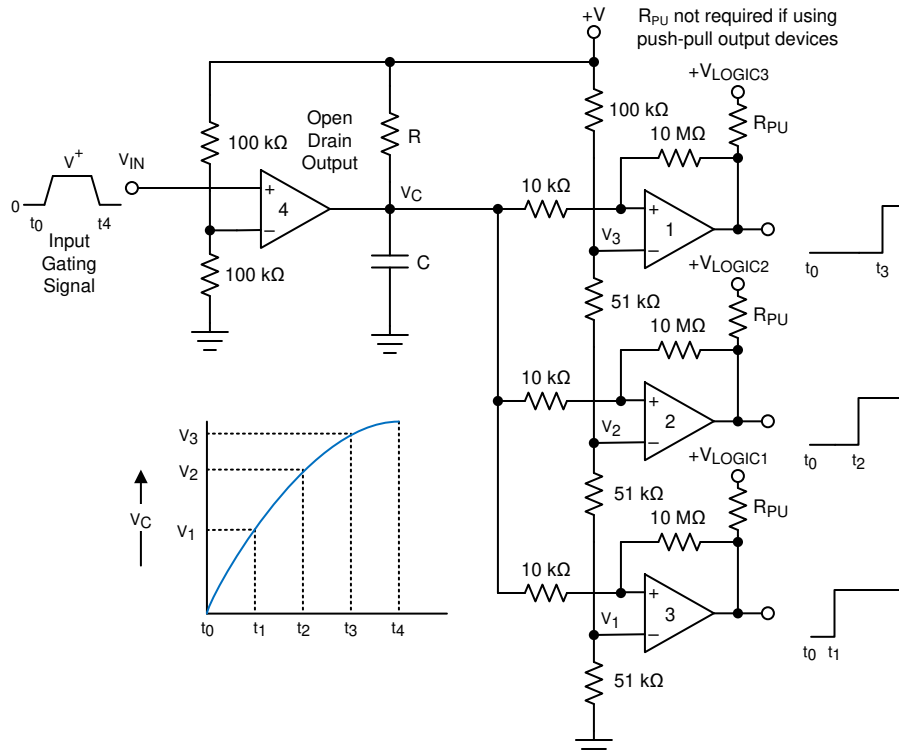

Figure 9-13. Time Delay Generator

Consider the case of $V_{IN} = 0$. The output of comparator 4 is also at ground, "shorting" the capacitor and holding it at 0V. This implies that the outputs of comparators 1, 2, and 3 are also at 0V. When an input signal is applied, the output of open drain comparator 4 goes High-Z and C charges exponentially through R. This is indicated in the graph. The output voltages of comparators 1, 2, and 3 switch to the high state in sequence when V_C rises above the reference voltages V_1 , V_2 and V_3 . A small amount of hysteresis has been provided by the 10 k Ω and 10 M Ω resistors to insure fast switching when the RC time constant is chosen to give long delay times. A good starting point is $R = 100$ k Ω and $C = 0.01$ μ F to 1 μ F.

All outputs will immediately go low when V_{IN} falls to 0V, due to the comparator output going low and immediately discharging the capacitor.

Comparator 4 must be a open-drain type output (TLV182x), whereas comparators 1 through 3 may be either open drain or push-pull output, depending on system requirements. R_{PU} is not required for push-pull output devices.

9.2.5 Logic Level Shifter

The output of the TLV182x is the uncommitted drain of the output transistor. Many open-drain outputs can be tied together to provide an output OR'ing function if desired.

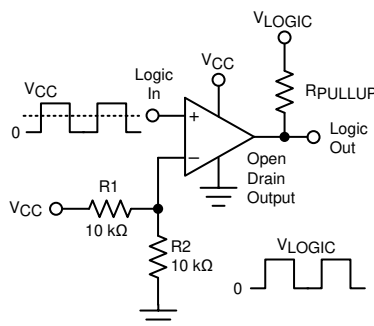

Figure 9-14. Universal Logic Level Shifter

The two 10 k Ω resistors bias the input to half of the input logic supply level to set the threshold in the mid-point of the input logic levels. Only one shared output pull-up resistor is needed and may be connected to any pull-up voltage between 0 V and 5.5 V. The pullup voltage should match the driven logic input "high" level.

9.2.6 One-Shot Multivibrator

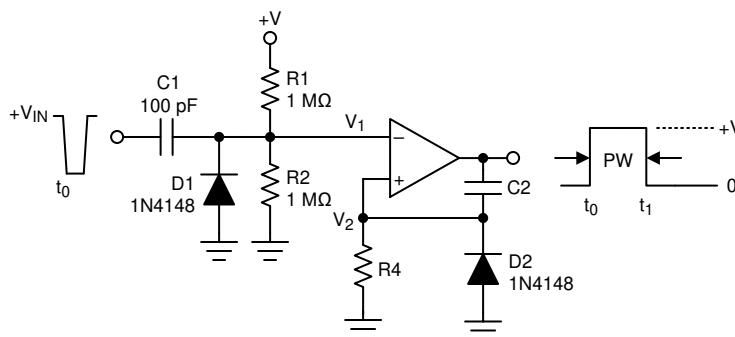

Figure 9-15. One-Shot Multivibrator

A monostable multivibrator has one stable state in which it can remain indefinitely. It can be triggered externally to another quasi-stable state. A monostable multivibrator can thus be used to generate a pulse of desired width.

The desired pulse width is set by adjusting the values of C_2 and R_4 . The resistor divider of R_1 and R_2 can be used to determine the magnitude of the input trigger pulse. The output will change state when $V_1 < V_2$. Diode D_2 provides a rapid discharge path for capacitor C_2 to reset at the end of the pulse. The diode also prevents the non-inverting input from being driven below ground.

9.2.7 Bi-Stable Multivibrator

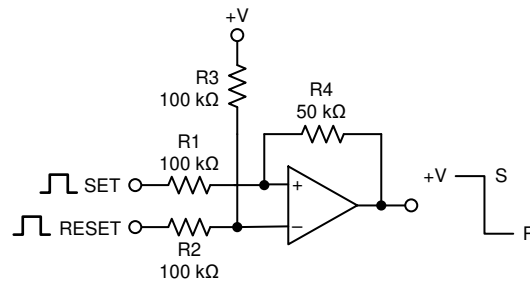

Figure 9-16. Bi-Stable Multivibrator

A bi-stable multivibrator has two stable states. The reference voltage is set up by the voltage divider of R_2 and R_3 . A pulse applied to the SET terminal will switch the output of the comparator high. The resistor divider of R_1 and R_4 now sets the non-inverting input to a voltage greater than the reference voltage. A pulse applied to RESET will now toggle the output low.

9.2.8 Zero Crossing Detector

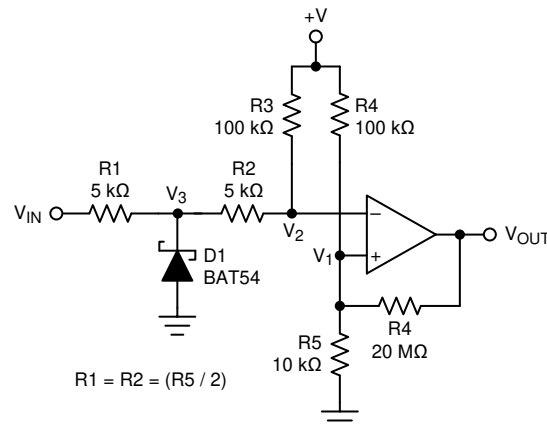

Figure 9-17. Zero Crossing Detector

A voltage divider of R_4 and R_5 establishes a reference voltage V_1 at the non-inverting input. By making the series resistance of R_1 and R_2 equal to R_5 , the comparator will switch when $V_{IN} = 0$. Diode D_1 insures that V_3 clamps near ground. The voltage divider of R_2 and R_3 then prevents V_2 from going below ground. A small amount of hysteresis is setup to ensure rapid output voltage transitions.

9.2.9 Pulse Slicer

A Pulse Slicer is a variation of the Zero Crossing Detector and is used to detect the zero crossings on an input signal with a varying baseline level. This circuit works best with symmetrical waveforms. The RC network of R_1 and C_1 establishes an mean reference voltage V_{REF} , which tracks the mean amplitude of the V_{IN} signal. The non-inverting input is directly connected to V_{REF} through R_2 . R_2 and R_3 are used to produce hysteresis to keep transitions free of spurious toggles. The time constant is a tradeoff between long-term symmetry and response time to changes in amplitude.

If the waveform is data, it is recommended that the data be encoded in NRZ (Non-Return to Zero) format to maintain proper average baseline. Asymmetrical inputs may suffer from timing distortions caused by the changing V_{REF} average voltage.

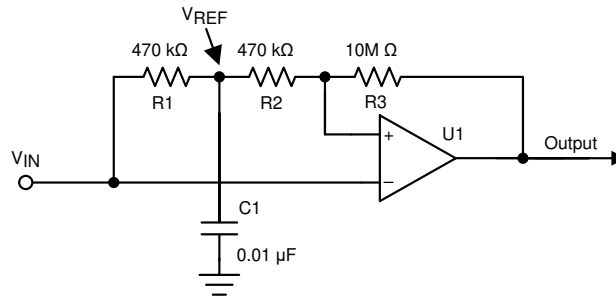

Figure 9-18. Pulse Slicer

For this design, follow these design requirements:

- The RC constant value (R_2 and C_1) must support the targeted data rate to maintain a valid tripping threshold.
- The hysteresis introduced with R_2 and R_{43} helps to avoid spurious output toggles.

The TLV182x may also be used, but with the addition of a pull-up resistor on the output (not shown for clarity).

Figure 9-19 shows the results of a 9600 baud data signal riding on a varying baseline.

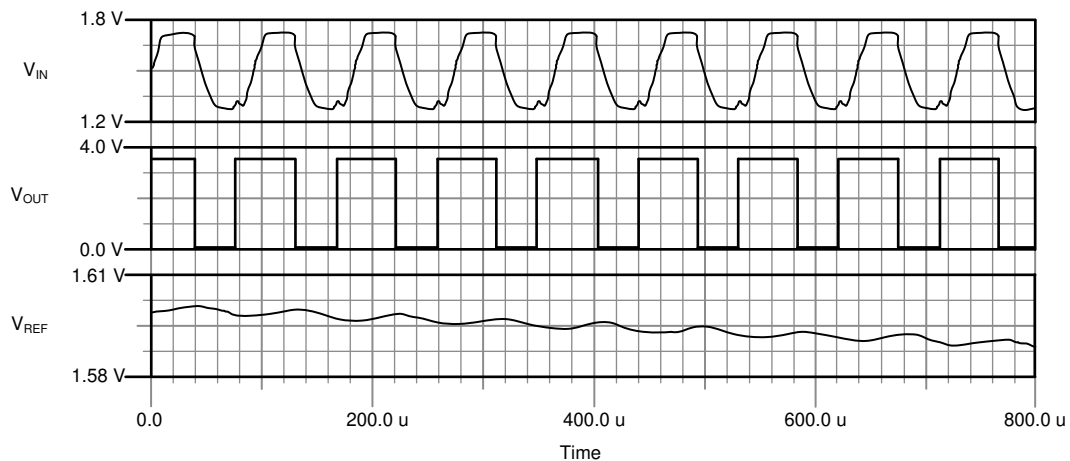

Figure 9-19. Pulse Slicer Waveforms

9.3 Power Supply Recommendations

Due to the fast output edges, it is critical to have bypass capacitors on the supply pin to prevent supply ringing and false triggers and oscillations. Bypass the supply directly at *each* device with a low ESR 0.1 μF ceramic bypass capacitor directly between V_{CC} pin and ground pins. Narrow, peak currents will be drawn during the output transition time, particularly for the push-pull output device. These narrow pulses can cause un-bypassed supply lines and poor grounds to ring, possibly causing variation that can eat into the input voltage range and create an inaccurate comparison or even oscillations.

The device may be powered from both "split" supplies ($V+$ and $V-$), or "single" supplies ($V+$ and GND), with GND applied to the $V-$ pin. Input signals must stay within the specified input range (between $V+$ and $V-$) for either type. Note that with a "split" supply the output will now swing "low" (V_{OL}) to $V-$ potential and not GND.

9.4 Layout

9.4.1 Layout Guidelines

For accurate comparator applications it is important maintain a stable power supply with minimized noise and glitches. Output rise and fall times are in the tens of nanoseconds, and should be treated as high speed logic devices. The bypass capacitor should be as close to the supply pin as possible and connected to a solid ground plane, and preferably directly between the V_{CC} and GND pins.

Minimize coupling between outputs and inputs to prevent output oscillations. Do not run output and input traces in parallel unless there is a V_{CC} or GND trace between output to reduce coupling. When series resistance is added to inputs, place resistor close to the device. A low value (<100 ohms) resistor may also be added in series with the output to dampen any ringing or reflections on long, non-impedance controlled traces. For best edge shapes, controlled impedance traces with back-terminations should be used when routing long distances.

9.4.2 Layout Example

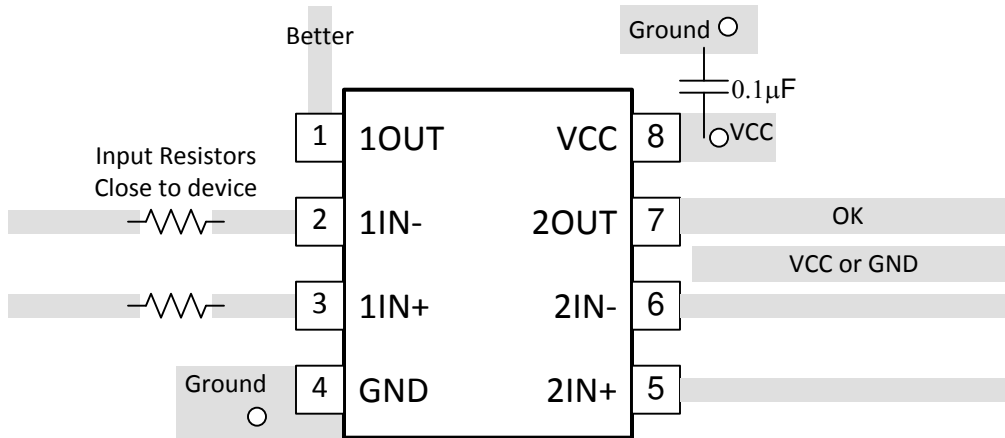

Figure 9-20. Dual Layout Example

10 Device and Documentation Support

10.1 Documentation Support

10.1.1 Related Documentation

[Analog Engineers Circuit Cookbook: Amplifiers \(See Comparators section\) - SLYY137](#)

[Precision Design, Comparator with Hysteresis Reference Design— TIDU020](#)

[Window comparator circuit - SBOA221](#)

[Reference Design, Window Comparator Reference Design— TIPD178](#)

[Comparator with and without hysteresis circuit - SBOA219](#)

[Inverting comparator with hysteresis circuit - SNOA997](#)

[Non-Inverting Comparator With Hysteresis Circuit - SBOA313](#)

[Zero crossing detection using comparator circuit - SNOA999](#)

[PWM generator circuit - SBOA212](#)

[How to Implement Comparators for Improving Performance of Rotary Encoder in Industrial Drive Applications - SNOAA41](#)

[A Quad of Independently Func Comparators - SNOA654](#)

10.2 Receiving Notification of Documentation Updates

To receive notification of documentation updates, navigate to the device product folder on ti.com. Click on *Subscribe to updates* to register and receive a weekly digest of any product information that has changed. For change details, review the revision history included in any revised document.

10.3 Support Resources

[TI E2E™ support forums](#) are an engineer's go-to source for fast, verified answers and design help — straight from the experts. Search existing answers or ask your own question to get the quick design help you need.

Linked content is provided "AS IS" by the respective contributors. They do not constitute TI specifications and do not necessarily reflect TI's views; see TI's [Terms of Use](#).

10.4 Trademarks

TI E2E™ is a trademark of Texas Instruments.

All trademarks are the property of their respective owners.

10.5 Electrostatic Discharge Caution



This integrated circuit can be damaged by ESD. Texas Instruments recommends that all integrated circuits be handled with appropriate precautions. Failure to observe proper handling and installation procedures can cause damage.

ESD damage can range from subtle performance degradation to complete device failure. Precision integrated circuits may be more susceptible to damage because very small parametric changes could cause the device not to meet its published specifications.

10.6 Glossary

[TI Glossary](#) This glossary lists and explains terms, acronyms, and definitions.

11 Mechanical, Packaging, and Orderable Information

The following pages include mechanical, packaging, and orderable information. This information is the most current data available for the designated devices. This data is subject to change without notice and revision of this document. For browser-based versions of this data sheet, refer to the left-hand navigation.

PACKAGING INFORMATION

Orderable Device	Status (1)	Package Type	Package Drawing	Pins	Package Qty	Eco Plan (2)	Lead finish/ Ball material (6)	MSL Peak Temp (3)	Op Temp (°C)	Device Marking (4/5)	Samples
TLV1811DBVR	ACTIVE	SOT-23	DBV	5	3000	RoHS & Green	SN	Level-1-260C-UNLIM	-40 to 125	2XJT	Samples
TLV1811LDBVR	ACTIVE	SOT-23	DBV	5	3000	RoHS & Green	SN	Level-1-260C-UNLIM	-40 to 125	2XNT	Samples
TLV1812DR	ACTIVE	SOIC	D	8	3000	RoHS & Green	NIPDAU	Level-1-260C-UNLIM	-40 to 125	TL1812	Samples
TLV1821DBVR	ACTIVE	SOT-23	DBV	5	3000	RoHS & Green	SN	Level-1-260C-UNLIM	-40 to 125	2XLT	Samples
TLV1821LDBVR	ACTIVE	SOT-23	DBV	5	3000	RoHS & Green	SN	Level-1-260C-UNLIM	-40 to 125	2XMT	Samples
TLV1822DR	ACTIVE	SOIC	D	8	3000	RoHS & Green	NIPDAU	Level-1-260C-UNLIM	-40 to 125	TL1822	Samples

(1) The marketing status values are defined as follows:

ACTIVE: Product device recommended for new designs.

LIFEBUY: TI has announced that the device will be discontinued, and a lifetime-buy period is in effect.

NRND: Not recommended for new designs. Device is in production to support existing customers, but TI does not recommend using this part in a new design.

PREVIEW: Device has been announced but is not in production. Samples may or may not be available.

OBSELETE: TI has discontinued the production of the device.

(2) **RoHS:** TI defines "RoHS" to mean semiconductor products that are compliant with the current EU RoHS requirements for all 10 RoHS substances, including the requirement that RoHS substance do not exceed 0.1% by weight in homogeneous materials. Where designed to be soldered at high temperatures, "RoHS" products are suitable for use in specified lead-free processes. TI may reference these types of products as "Pb-Free".

RoHS Exempt: TI defines "RoHS Exempt" to mean products that contain lead but are compliant with EU RoHS pursuant to a specific EU RoHS exemption.

Green: TI defines "Green" to mean the content of Chlorine (Cl) and Bromine (Br) based flame retardants meet JS709B low halogen requirements of <=1000ppm threshold. Antimony trioxide based flame retardants must also meet the <=1000ppm threshold requirement.

(3) MSL, Peak Temp. - The Moisture Sensitivity Level rating according to the JEDEC industry standard classifications, and peak solder temperature.

(4) There may be additional marking, which relates to the logo, the lot trace code information, or the environmental category on the device.

(5) Multiple Device Markings will be inside parentheses. Only one Device Marking contained in parentheses and separated by a "-" will appear on a device. If a line is indented then it is a continuation of the previous line and the two combined represent the entire Device Marking for that device.

(6) Lead finish/Ball material - Orderable Devices may have multiple material finish options. Finish options are separated by a vertical ruled line. Lead finish/Ball material values may wrap to two lines if the finish value exceeds the maximum column width.

Important Information and Disclaimer: The information provided on this page represents TI's knowledge and belief as of the date that it is provided. TI bases its knowledge and belief on information provided by third parties, and makes no representation or warranty as to the accuracy of such information. Efforts are underway to better integrate information from third parties. TI has taken and continues to take reasonable steps to provide representative and accurate information but may not have conducted destructive testing or chemical analysis on incoming materials and chemicals. TI and TI suppliers consider certain information to be proprietary, and thus CAS numbers and other limited information may not be available for release.

In no event shall TI's liability arising out of such information exceed the total purchase price of the TI part(s) at issue in this document sold by TI to Customer on an annual basis.

OTHER QUALIFIED VERSIONS OF TLV1812, TLV1822 :

- Automotive : [TLV1812-Q1](#), [TLV1822-Q1](#)

NOTE: Qualified Version Definitions:

- Automotive - Q100 devices qualified for high-reliability automotive applications targeting zero defects

TAPE AND REEL INFORMATION

QUADRANT ASSIGNMENTS FOR PIN 1 ORIENTATION IN TAPE

*All dimensions are nominal

Device	Package Type	Package Drawing	Pins	SPQ	Reel Diameter (mm)	Reel Width W1 (mm)	A0 (mm)	B0 (mm)	K0 (mm)	P1 (mm)	W (mm)	Pin1 Quadrant
TLV1811DBVR	SOT-23	DBV	5	3000	178.0	9.0	2.4	2.5	1.2	4.0	8.0	Q3
TLV1811LDBVR	SOT-23	DBV	5	3000	178.0	9.0	2.4	2.5	1.2	4.0	8.0	Q3
TLV1812DR	SOIC	D	8	3000	330.0	12.4	6.4	5.2	2.1	8.0	12.0	Q1
TLV1821DBVR	SOT-23	DBV	5	3000	178.0	9.0	2.4	2.5	1.2	4.0	8.0	Q3
TLV1821LDBVR	SOT-23	DBV	5	3000	178.0	9.0	2.4	2.5	1.2	4.0	8.0	Q3
TLV1822DR	SOIC	D	8	3000	330.0	12.4	6.4	5.2	2.1	8.0	12.0	Q1

TAPE AND REEL BOX DIMENSIONS

*All dimensions are nominal

Device	Package Type	Package Drawing	Pins	SPQ	Length (mm)	Width (mm)	Height (mm)
TLV1811DBVR	SOT-23	DBV	5	3000	180.0	180.0	18.0
TLV1811LDBVR	SOT-23	DBV	5	3000	180.0	180.0	18.0
TLV1812DR	SOIC	D	8	3000	356.0	356.0	35.0
TLV1821DBVR	SOT-23	DBV	5	3000	180.0	180.0	18.0
TLV1821LDBVR	SOT-23	DBV	5	3000	180.0	180.0	18.0
TLV1822DR	SOIC	D	8	3000	356.0	356.0	35.0

DBV0005A



PACKAGE OUTLINE

SOT-23 - 1.45 mm max height

SMALL OUTLINE TRANSISTOR

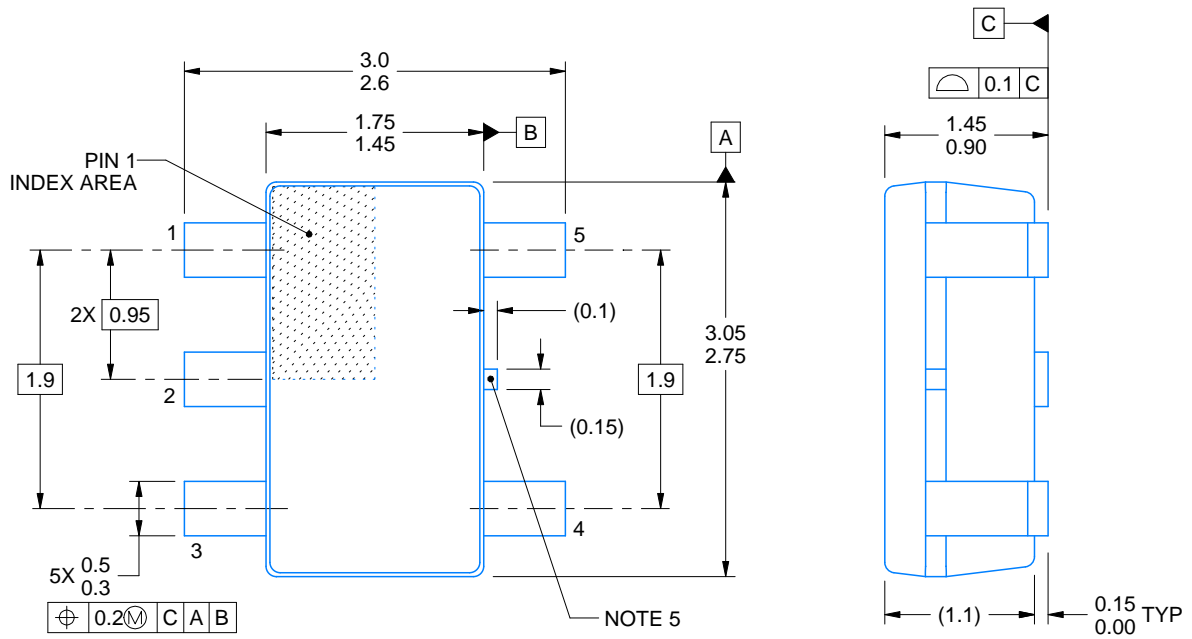

4214839/G 03/2023

NOTES:

1. All linear dimensions are in millimeters. Any dimensions in parenthesis are for reference only. Dimensioning and tolerancing per ASME Y14.5M.
2. This drawing is subject to change without notice.
3. Reference JEDEC MO-178.
4. Body dimensions do not include mold flash, protrusions, or gate burrs. Mold flash, protrusions, or gate burrs shall not exceed 0.25 mm per side.
5. Support pin may differ or may not be present.

EXAMPLE BOARD LAYOUT

DBV0005A

SOT-23 - 1.45 mm max height

SMALL OUTLINE TRANSISTOR

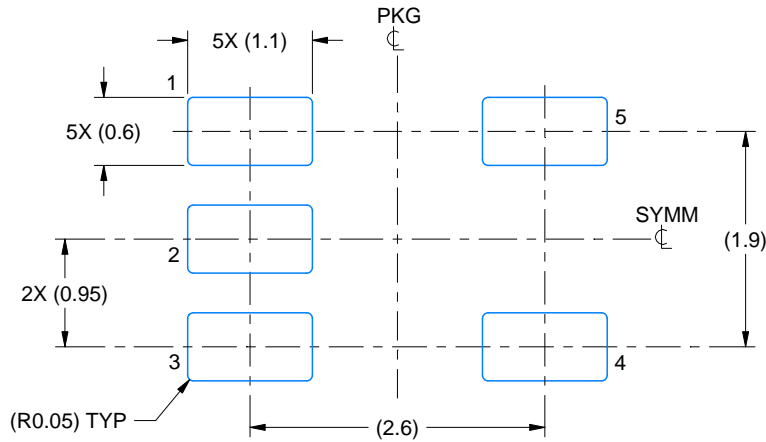

LAND PATTERN EXAMPLE
EXPOSED METAL SHOWN
SCALE:15X



SOLDER MASK DETAILS

4214839/G 03/2023

NOTES: (continued)

- 6. Publication IPC-7351 may have alternate designs.
- 7. Solder mask tolerances between and around signal pads can vary based on board fabrication site.

EXAMPLE STENCIL DESIGN

DBV0005A

SOT-23 - 1.45 mm max height

SMALL OUTLINE TRANSISTOR



SOLDER PASTE EXAMPLE
BASED ON 0.125 mm THICK STENCIL
SCALE:15X

4214839/G 03/2023

NOTES: (continued)

8. Laser cutting apertures with trapezoidal walls and rounded corners may offer better paste release. IPC-7525 may have alternate design recommendations.
9. Board assembly site may have different recommendations for stencil design.



D0008A

PACKAGE OUTLINE

SOIC - 1.75 mm max height

SMALL OUTLINE INTEGRATED CIRCUIT



4214825/C 02/2019

NOTES:

- Linear dimensions are in inches [millimeters]. Dimensions in parenthesis are for reference only. Controlling dimensions are in inches. Dimensioning and tolerancing per ASME Y14.5M.
- This drawing is subject to change without notice.
- This dimension does not include mold flash, protrusions, or gate burrs. Mold flash, protrusions, or gate burrs shall not exceed .006 [0.15] per side.
- This dimension does not include interlead flash.
- Reference JEDEC registration MS-012, variation AA.

EXAMPLE BOARD LAYOUT

D0008A

SOIC - 1.75 mm max height

SMALL OUTLINE INTEGRATED CIRCUIT



LAND PATTERN EXAMPLE
EXPOSED METAL SHOWN
SCALE:8X



SOLDER MASK DETAILS

4214825/C 02/2019

NOTES: (continued)

6. Publication IPC-7351 may have alternate designs.

7. Solder mask tolerances between and around signal pads can vary based on board fabrication site.

EXAMPLE STENCIL DESIGN

D0008A

SOIC - 1.75 mm max height

SMALL OUTLINE INTEGRATED CIRCUIT



SOLDER PASTE EXAMPLE
BASED ON .005 INCH [0.125 MM] THICK STENCIL
SCALE:8X

4214825/C 02/2019

NOTES: (continued)

8. Laser cutting apertures with trapezoidal walls and rounded corners may offer better paste release. IPC-7525 may have alternate design recommendations.
9. Board assembly site may have different recommendations for stencil design.

IMPORTANT NOTICE AND DISCLAIMER

TI PROVIDES TECHNICAL AND RELIABILITY DATA (INCLUDING DATA SHEETS), DESIGN RESOURCES (INCLUDING REFERENCE DESIGNS), APPLICATION OR OTHER DESIGN ADVICE, WEB TOOLS, SAFETY INFORMATION, AND OTHER RESOURCES "AS IS" AND WITH ALL FAULTS, AND DISCLAIMS ALL WARRANTIES, EXPRESS AND IMPLIED, INCLUDING WITHOUT LIMITATION ANY IMPLIED WARRANTIES OF MERCHANTABILITY, FITNESS FOR A PARTICULAR PURPOSE OR NON-INFRINGEMENT OF THIRD PARTY INTELLECTUAL PROPERTY RIGHTS.

These resources are intended for skilled developers designing with TI products. You are solely responsible for (1) selecting the appropriate TI products for your application, (2) designing, validating and testing your application, and (3) ensuring your application meets applicable standards, and any other safety, security, regulatory or other requirements.

These resources are subject to change without notice. TI grants you permission to use these resources only for development of an application that uses the TI products described in the resource. Other reproduction and display of these resources is prohibited. No license is granted to any other TI intellectual property right or to any third party intellectual property right. TI disclaims responsibility for, and you will fully indemnify TI and its representatives against, any claims, damages, costs, losses, and liabilities arising out of your use of these resources.

TI's products are provided subject to [TI's Terms of Sale](#) or other applicable terms available either on [ti.com](https://www.ti.com) or provided in conjunction with such TI products. TI's provision of these resources does not expand or otherwise alter TI's applicable warranties or warranty disclaimers for TI products.

TI objects to and rejects any additional or different terms you may have proposed.

Mailing Address: Texas Instruments, Post Office Box 655303, Dallas, Texas 75265
Copyright © 2023, Texas Instruments Incorporated

X-ON Electronics

Largest Supplier of Electrical and Electronic Components

Click to view similar products for [Analog Comparators](#) category:

Click to view products by [Texas Instruments](#) manufacturer:

Other Similar products are found below :

[SC2903VDR2G](#) [LM2901SNG](#) [LM339SNG](#) [5962-8757203IA](#) [NTE911](#) [LM339EDR2G](#) [NTE922](#) [UPC311G2-E1-A](#) [UPC311G2-E2-A](#)
[UPC272G2-E1-A](#) [UPC277G2-E2-A](#) [UPC177G2-E2-A](#) [UPC271G2-E2-A](#) [TLV1811DBVR](#) [HT393VRMZ](#) [LM2903YD](#) [NCV2200SN1T1G](#)
[LM2903A-SR](#) [LM2903A-VR](#) [HT393ARZ](#) [LM2903](#) [LM2904](#) [LM393D](#) [LM393](#) [LMV331SN3T1G](#) [LMV331ILT](#) [LMV331W5](#)
[LMV331IDBVR](#) [LMV331M5X](#) [TPV331S5](#) [LM339A-SR](#) [GS8748-SR](#) [LM311MM/TR](#) [LM211MM/TR](#) [HT339ARQZ](#) [LM393DR-HXY](#)
[LM2903XK-Q1](#) [RS393XK-Q1](#) [LM2903XM](#) [RS339XQ](#) [LM331CXF](#) [RS393XM](#) [LM2901XP](#) [LM2901DR-JSM](#) [LM239DR-JSM](#) [LM339](#)
[LR2903D](#) [TS391IL](#) [LM331A-S5TR](#) [GSV331R-TR](#)