

TMUX113x 5V、低泄漏电流、2:1 (SPDT)、3 通道或 4 通道精密开关

1 特性

- 单电源电压范围：1.08V 至 5.5V
- 双电源电压范围：±2.75V
- 低泄漏电流：3pA
- 低电荷注入：-1pC
- 低导通电阻：2Ω
- -40°C 至 +125°C 工作温度
- 兼容 1.8V 逻辑
- 失效防护逻辑
- 轨至轨运行
- 双向信号路径
- 先断后合开关
- ESD 保护 HBM：2000V

2 应用

- 现场变送器
- 可编程逻辑控制器 (PLC)
- 工厂自动化和控制
- 超声波扫描仪
- 患者监护和诊断
- 心电图 (ECG)
- 数据采集系统 (DAQ)
- ATE 测试设备
- 电池测试设备
- 仪表：实验室、分析、便携
- 智能仪表：水表和燃气表
- 光纤网络
- 光学测试设备
- 便携式 POS
- 远程无线电单元
- 有源天线系统 (mMIMIO)

3 说明

TMUX113x 器件是具有多个通道的精密互补金属氧化物半导体 (CMOS) 开关。TMUX1133 是 2:1 单极双投 (SPDT) 开关，具有三个独立控制的通道和一个 $\overline{\text{EN}}$ 引脚，用于启用或禁用全部三个开关。TMUX1134 包含四个独立控制的 SPDT 开关。1.08V 至 5.5V 或 ±2.75V 双电源的宽电源电压工作范围可支持医疗设备到工业系统的大量应用。该器件可支持源极 (Sx) 和漏极 (Dx) 引脚上 V_{SS} 到 V_{DD} 范围的双向模拟和数字信号。对于单电源应用， V_{SS} 必须连接至 GND。

所有逻辑输入均具有兼容 1.8V 逻辑的阈值，当器件在有效电源电压范围内运行时，这些阈值可确保 TTL 和 CMOS 逻辑兼容性。失效防护逻辑电路允许在电源引脚之前的控制引脚上施加电压，从而保护器件免受潜在的损害。

TMUX113x 器件是精密开关和多路复用器器件系列中的一部分。这些器件具有非常低的导通和关断泄漏电流以及较低的电荷注入，因此可用于高精度测量应用理想之选。8nA 的低电源电流可用于便携式应用的。

器件信息(1)

器件型号	封装	封装尺寸 (标称值)
TMUX1133	TSSOP (16) (PW)	5.00mm × 4.40mm
TMUX1134	TSSOP (20) (PW)	6.50mm × 4.40mm

(1) 如需了解所有可用封装，请参阅产品说明书末尾的封装选项附录。

TMUX113x 方框图

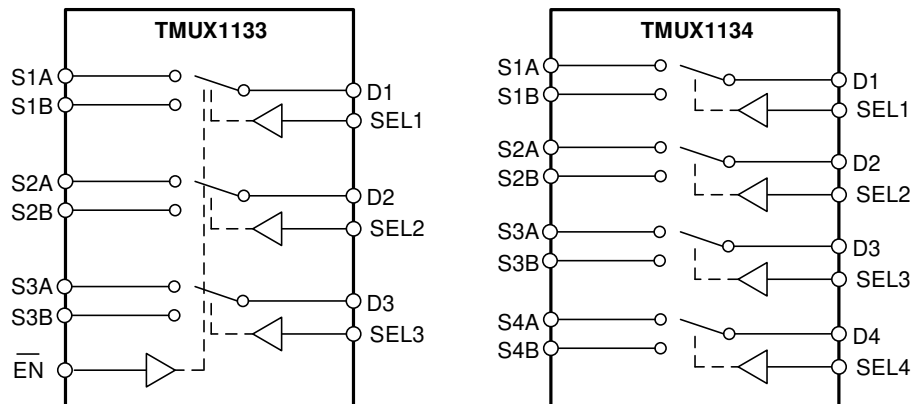

目录

<p>1 特性 1</p> <p>2 应用 1</p> <p>3 说明 1</p> <p>4 修订历史记录 2</p> <p>5 Device Comparison Table 3</p> <p>6 Pin Configuration and Functions 3</p> <p>7 Specifications 5</p> <p> 7.1 Absolute Maximum Ratings 5</p> <p> 7.2 ESD Ratings 5</p> <p> 7.3 Recommended Operating Conditions 5</p> <p> 7.4 Thermal Information 5</p> <p> 7.5 Electrical Characteristics ($V_{DD} = 5\text{ V} \pm 10\%$) 6</p> <p> 7.6 Electrical Characteristics ($V_{DD} = 3.3\text{ V} \pm 10\%$) 8</p> <p> 7.7 Electrical Characteristics ($V_{DD} = 2.5\text{ V} \pm 10\%$), ($V_{SS} = -2.5\text{ V} \pm 10\%$) 10</p> <p> 7.8 Electrical Characteristics ($V_{DD} = 1.8\text{ V} \pm 10\%$) 12</p> <p> 7.9 Electrical Characteristics ($V_{DD} = 1.2\text{ V} \pm 10\%$) 14</p> <p> 7.10 Typical Characteristics 16</p> <p>8 Parameter Measurement Information 19</p> <p> 8.1 On-Resistance 19</p> <p> 8.2 Off-Leakage Current 19</p> <p> 8.3 On-Leakage Current 20</p> <p> 8.4 Transition Time 20</p> <p> 8.5 Break-Before-Make 21</p> <p> 8.6 $t_{ON(EN)}$ and $t_{OFF(EN)}$ 21</p> <p> 8.7 Charge Injection 22</p> <p> 8.8 Off Isolation 22</p>	<p> 8.9 Crosstalk 23</p> <p> 8.10 Bandwidth 23</p> <p>9 Detailed Description 24</p> <p> 9.1 Overview 24</p> <p> 9.2 Functional Block Diagram 24</p> <p> 9.3 Feature Description 24</p> <p> 9.4 Device Functional Modes 26</p> <p> 9.5 Truth Tables 26</p> <p>10 Application and Implementation 27</p> <p> 10.1 Application Information 27</p> <p> 10.2 Typical Application 27</p> <p> 10.3 Design Requirements 27</p> <p> 10.4 Detailed Design Procedure 28</p> <p> 10.5 Application Curve 28</p> <p>11 Power Supply Recommendations 29</p> <p>12 Layout 29</p> <p> 12.1 Layout Guidelines 29</p> <p> 12.2 Layout Example 30</p> <p>13 器件和文档支持 31</p> <p> 13.1 文档支持 31</p> <p> 13.2 相关链接 31</p> <p> 13.3 接收文档更新通知 31</p> <p> 13.4 社区资源 31</p> <p> 13.5 商标 31</p> <p> 13.6 静电放电警告 31</p> <p> 13.7 Glossary 31</p> <p>14 机械、封装和可订购信息 31</p>
----------------------------------------------------------------------------------------------------------------------------------------------------------------------------------------------------------------------------------------------------------------------------------------------------------------------------------------------------------------------------------------------------------------------------------------------------------------------------------------------------------------------------------------------------------------------------------------------------------------------------------------------------------------------------------------------------------------------------------------------------------------------------------------------------------------------------------------------------------------------------------------------------------------------------------------------------------------------------------------------------------------------------------------------------------------------------------------------------------------------------------------------------------------------------------------------------------------------------------------------------------------------------------------------------------------------------------------------------------------------------------------------------------------------------------------------------------------------------------------------	----------------------------------------------------------------------------------------------------------------------------------------------------------------------------------------------------------------------------------------------------------------------------------------------------------------------------------------------------------------------------------------------------------------------------------------------------------------------------------------------------------------------------------------------------------------------------------------------------------------------------------------------------------------------------------------------------------------------------------------------------------------------------------------------------------------------------------------------------------------------------------------------------------------------------------------------------------------------------------------------------------------------------------------------------------------------------------------------------------------------

4 修订历史记录

注：之前版本的页码可能与当前版本有所不同。

Changes from Original (June 2019) to Revision A	Page
• 将器件从预告信息 更改为生产 数据	1

5 Device Comparison Table

PRODUCT	DESCRIPTION
TMUX1133	2:1 (SPDT), 3-Channel Switch
TMUX1134	2:1 (SPDT), 4-Channel Switch

6 Pin Configuration and Functions

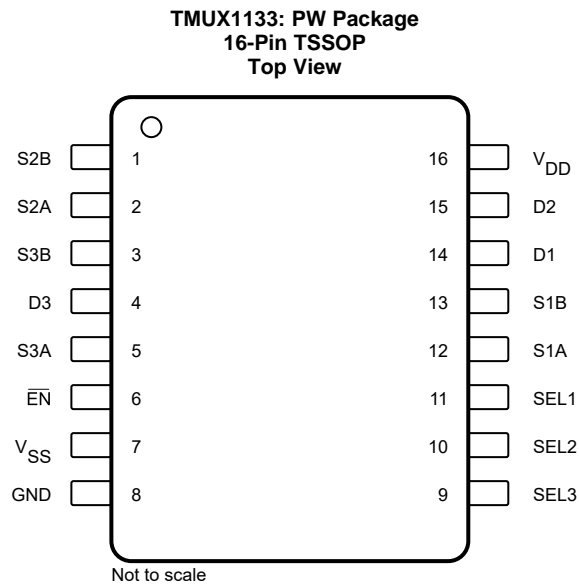

Pin Functions TMUX1133

PIN		TYPE ⁽¹⁾	DESCRIPTION ⁽²⁾
NAME	NO.		
S2B	1	I/O	Source pin 2B. Can be an input or output.
S2A	2	I/O	Source pin 2A. Can be an input or output.
S3B	3	I/O	Source pin 3B. Can be an input or output.
D3	4	I/O	Drain pin 3. Can be an input or output.
S3A	5	I/O	Source pin 3A. Can be an input or output.
$\overline{\text{EN}}$	6	I	Active low logic enable. When this pin is high, all switches are turned off. When this pin is low, the SELx inputs determine switch connection as shown in 表 1 .
V _{SS}	7	P	Negative power supply. This pin is the most negative power-supply potential. For reliable operation, connect a decoupling capacitor ranging from 0.1 μF to 10 μF between V _{SS} and GND. V _{SS} must be connected to ground for single supply voltage applications.
GND	8	P	Ground (0 V) reference
SEL3	9	I	Logic control select pin 3. Controls switch 3 connection as shown in 表 1 .
SEL2	10	I	Logic control select pin 2. Controls switch 2 connection as shown in 表 1 .
SEL1	11	I	Logic control select pin 1. Controls switch 1 connection as shown in 表 1 .
S1A	12	I/O	Source pin 1A. Can be an input or output.
S1B	13	I/O	Source pin 1B. Can be an input or output.
D1	14	I/O	Drain pin 1. Can be an input or output.
D2	15	I/O	Drain pin 2. Can be an input or output.
V _{DD}	16	P	Positive power supply. This pin is the most positive power-supply potential. For reliable operation, connect a decoupling capacitor ranging from 0.1 μF to 10 μF between V _{DD} and GND.

(1) I = input, O = output, I/O = input and output, P = power

(2) Refer to [Device Functional Modes](#) for what to do with unused pins

**TMUX1134: PW Package
20-Pin TSSOP
Top View**

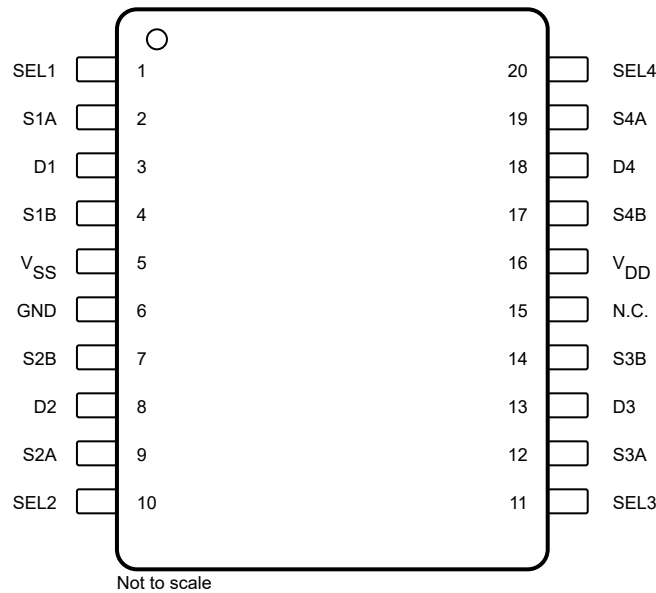

Pin Functions TMUX1134

PIN		TYPE ⁽¹⁾	DESCRIPTION ⁽²⁾
NAME	NO.		
SEL1	1	I	Logic control select pin 1. Controls switch 1 connection as shown in 表 2 .
S1A	2	I/O	Source pin 1A. Can be an input or output.
D1	3	I/O	Drain pin 1. Can be an input or output.
S1B	4	I/O	Source pin 1B. Can be an input or output.
V _{SS}	5	P	Negative power supply. This pin is the most negative power-supply potential. For reliable operation, connect a decoupling capacitor ranging from 0.1 μF to 10 μF between V _{SS} and GND. V _{SS} must be connected to ground for single supply voltage applications.
GND	6	P	Ground (0 V) reference.
S2B	7	I/O	Source pin 2B. Can be an input or output.
D2	8	I/O	Drain pin 2. Can be an input or output.
S2A	9	I/O	Source pin 2A. Can be an input or output.
SEL2	10	I	Logic control select pin 2. Controls switch 2 connection as shown in 表 2 .
SEL3	11	I	Logic control select pin 3. Controls switch 3 connection as shown in 表 2 .
S3A	12	I/O	Source pin 3A. Can be an input or output.
D3	13	I/O	Drain pin 3. Can be an input or output.
S3B	14	I/O	Source pin 3B. Can be an input or output.
N.C.	15	Not Connected	Not Connected. Can be shorted to GND or left floating.
V _{DD}	16	P	Positive power supply. This pin is the most positive power-supply potential. For reliable operation, connect a decoupling capacitor ranging from 0.1 μF to 10 μF between V _{DD} and GND.
S4B	17	I/O	Source pin 4B. Can be an input or output.
D4	18	I/O	Drain pin 4. Can be an input or output.
S4A	19	I/O	Source pin 4A. Can be an input or output.
SEL4	20	I	Logic control select pin 4. Controls switch 4 connection as shown in 表 2 .

(1) I = input, O = output, I/O = input and output, P = power

(2) Refer to [Device Functional Modes](#) for what to do with unused pins

7 Specifications

7.1 Absolute Maximum Ratings

 over operating free-air temperature range (unless otherwise noted)⁽¹⁾⁽²⁾⁽³⁾

		MIN	MAX	UNIT
$V_{DD}-V_{SS}$	Supply voltage	-0.5	6	V
V_{DD}		-0.5	6	V
V_{SS}		-3.0	0.3	V
V_{SEL} or V_{EN}	Logic control input pin voltage (\overline{EN} , SELx)	-0.5	6	V
I_{SEL} or I_{EN}	Logic control input pin current (\overline{EN} , SELx)	-30	30	mA
V_S or V_D	Source or drain voltage (SxA, SxB, Dx)	-0.5	$V_{DD} + 0.5$	V
I_S or I_D (CONT)	Source or drain continuous current (SxA, SxB, Dx)	-30	30	mA
T_{stg}	Storage temperature	-65	150	°C
T_J	Junction temperature		150	°C

- (1) Stresses beyond those listed under *Absolute Maximum Rating* may cause permanent damage to the device. These are stress ratings only, which do not imply functional operation of the device at these or any other conditions beyond those indicated under *Recommended Operating Condition*. Exposure to absolute-maximum-rated conditions for extended periods may affect device reliability.
- (2) The algebraic convention, whereby the most negative value is a minimum and the most positive value is a maximum.
- (3) All voltages are with respect to ground, unless otherwise specified.

7.2 ESD Ratings

			VALUE	UNIT
$V_{(ESD)}$	Electrostatic discharge	Human body model (HBM), per ANSI/ESDA/JEDEC JS-001, all pins ⁽¹⁾	±2000	V
		Charged device model (CDM), per JEDEC specification JESD22-C101 or ANSI/ESDA/JEDEC JS-002, all pins ⁽²⁾	±750	

- (1) JEDEC document JEP155 states that 500-V HBM allows safe manufacturing with a standard ESD control process.
- (2) JEDEC document JEP157 states that 250-V CDM allows safe manufacturing with a standard ESD control process.

7.3 Recommended Operating Conditions

over operating free-air temperature range (unless otherwise noted)

		MIN	NOM	MAX	UNIT
V_{DD}	Positive power supply voltage (single)	1.08		5.5	V
V_{SS}	Negative power supply voltage (dual)	-2.75		0	V
$V_{DD} - V_{SS}$	Supply rail voltage difference	1.08		5.5	V
V_S or V_D	Signal path input/output voltage (source or drain pin) (SxA, SxB, Dx)	V_{SS}		V_{DD}	V
V_{SEL} or V_{EN}	Logic control input pin voltage (\overline{EN} , SELx)	0		5.5	V
T_A	Ambient temperature	-40		125	°C

7.4 Thermal Information

THERMAL METRIC ⁽¹⁾		TMUX1133	TMUX1134	UNIT
		PW (TSSOP)	PW (TSSOP)	
		16 PINS	16 PINS	
$R_{\theta JA}$	Junction-to-ambient thermal resistance	120.6	102.2	°C/W
$R_{\theta JC(top)}$	Junction-to-case (top) thermal resistance	51.0	43.1	°C/W
$R_{\theta JB}$	Junction-to-board thermal resistance	66.8	53.6	°C/W
Ψ_{JT}	Junction-to-top characterization parameter	8.7	6.6	°C/W
Ψ_{JB}	Junction-to-board characterization parameter	66.2	53.1	°C/W
$R_{\theta JC(bot)}$	Junction-to-case (bottom) thermal resistance	N/A	N/A	°C/W

- (1) For more information about traditional and new thermal metrics, see the [Semiconductor and IC Package Thermal Metrics](#) application report.

7.5 Electrical Characteristics ($V_{DD} = 5\text{ V} \pm 10\%$)

 at $T_A = 25^\circ\text{C}$, $V_{DD} = 5\text{ V}$ (unless otherwise noted)

PARAMETER		TEST CONDITIONS	TA	MIN	TYP	MAX	UNIT
ANALOG SWITCH							
R_{ON}	On-resistance	$V_S = 0\text{ V to }V_{DD}$ $I_{SD} = 10\text{ mA}$ Refer to On-Resistance	25°C		2	4	Ω
			–40°C to +85°C			4.5	Ω
			–40°C to +125°C			4.9	Ω
ΔR_{ON}	On-resistance matching between channels	$V_S = 0\text{ V to }V_{DD}$ $I_{SD} = 10\text{ mA}$ Refer to On-Resistance	25°C		0.18		Ω
			–40°C to +85°C			0.4	Ω
			–40°C to +125°C			0.5	Ω
$R_{ON\ FLAT}$	On-resistance flatness	$V_S = 0\text{ V to }V_{DD}$ $I_{SD} = 10\text{ mA}$ Refer to On-Resistance	25°C		0.85		Ω
			–40°C to +85°C			1.6	Ω
			–40°C to +125°C			1.6	Ω
$I_{S(OFF)}$	Source off leakage current ⁽¹⁾	$V_{DD} = 5\text{ V}$ Switch Off $V_D = 4.5\text{ V} / 1.5\text{ V}$ $V_S = 1.5\text{ V} / 4.5\text{ V}$ Refer to Off-Leakage Current	25°C	–0.08	± 0.003	0.08	nA
			–40°C to +85°C		–0.3	0.3	nA
			–40°C to +125°C		–0.9	0.9	nA
$I_{D(OFF)}$	Drain off leakage current ⁽¹⁾	$V_{DD} = 5\text{ V}$ Switch Off $V_D = 4.5\text{ V} / 1.5\text{ V}$ $V_S = 1.5\text{ V} / 4.5\text{ V}$ Refer to Off-Leakage Current	25°C	–0.1	± 0.003	0.1	nA
			–40°C to +85°C		–0.35	0.35	nA
			–40°C to +125°C		–2	2	nA
$I_{D(ON)}$ $I_{S(ON)}$	Channel on leakage current	$V_{DD} = 5\text{ V}$ Switch On $V_D = V_S = 4.5\text{ V} / 1.5\text{ V}$ Refer to On-Leakage Current	25°C	–0.1	± 0.003	0.1	nA
			–40°C to +85°C		–0.35	0.35	nA
			–40°C to +125°C		–2	2	nA
LOGIC INPUTS (\overline{EN}, SELx)							
V_{IH}	Input logic high		–40°C to +125°C	1.49		5.5	V
V_{IL}	Input logic low					0	0.87
I_{IH} I_{IL}	Input leakage current		25°C		± 0.005		μA
I_{IH} I_{IL}	Input leakage current		–40°C to +125°C			± 0.05	μA
C_{IN}	Logic input capacitance		25°C		1		pF
			–40°C to +125°C			2	pF
POWER SUPPLY							
I_{DD}	V_{DD} supply current	Logic inputs = 0 V or 5.5 V	25°C		0.008		μA
			–40°C to +125°C			1	μA

 (1) When V_S is 4.5 V, V_D is 1.5 V or when V_S is 1.5 V, V_D is 4.5 V.

Electrical Characteristics ($V_{DD} = 5\text{ V} \pm 10\%$) (continued)

at $T_A = 25^\circ\text{C}$, $V_{DD} = 5\text{ V}$ (unless otherwise noted)

PARAMETER		TEST CONDITIONS	TA	MIN	TYP	MAX	UNIT
DYNAMIC CHARACTERISTICS							
t_{TRAN}	Transition time between channels	$V_S = 3\text{ V}$ $R_L = 200\ \Omega$, $C_L = 15\text{ pF}$ Refer to Transition Time	25°C	12			ns
			–40°C to +85°C			18	ns
			–40°C to +125°C			19	ns
t_{OPEN} (BBM)	Break before make time	$V_S = 3\text{ V}$ $R_L = 200\ \Omega$, $C_L = 15\text{ pF}$ Refer to Break-Before-Make	25°C	8			ns
			–40°C to +85°C	1			ns
			–40°C to +125°C	1			ns
$t_{\text{ON(EN)}}$	Enable turn-on time (TMUX1133 Only)	$V_S = 3\text{ V}$ $R_L = 200\ \Omega$, $C_L = 15\text{ pF}$ Refer to $t_{\text{ON(EN)}}$ and $t_{\text{OFF(EN)}}$	25°C	12			ns
			–40°C to +85°C			21	ns
			–40°C to +125°C			22	ns
$t_{\text{OFF(EN)}}$	Enable turn-off time (TMUX1133 Only)	$V_S = 3\text{ V}$ $R_L = 200\ \Omega$, $C_L = 15\text{ pF}$ Refer to $t_{\text{ON(EN)}}$ and $t_{\text{OFF(EN)}}$	25°C	6			ns
			–40°C to +85°C			11	ns
			–40°C to +125°C			12	ns
Q_C	Charge Injection	$V_S = 1\text{ V}$ $R_S = 0\ \Omega$, $C_L = 1\text{ nF}$ Refer to Charge Injection	25°C		–1		pC
O_{ISO}	Off Isolation	$R_L = 50\ \Omega$, $C_L = 5\text{ pF}$ $f = 1\text{ MHz}$ Refer to Off Isolation	25°C		–65		dB
		$R_L = 50\ \Omega$, $C_L = 5\text{ pF}$ $f = 10\text{ MHz}$ Refer to Off Isolation	25°C		–45		dB
X_{TALK}	Crosstalk	$R_L = 50\ \Omega$, $C_L = 5\text{ pF}$ $f = 1\text{ MHz}$ Refer to Crosstalk	25°C		–100		dB
		$R_L = 50\ \Omega$, $C_L = 5\text{ pF}$ $f = 10\text{ MHz}$ Refer to Crosstalk	25°C		–90		dB
BW	Bandwidth	$R_L = 50\ \Omega$, $C_L = 5\text{ pF}$ Refer to Bandwidth	25°C		220		MHz
C_{SOFF}	Source off capacitance	$f = 1\text{ MHz}$	25°C		6		pF
C_{DOFF}	Drain off capacitance	$f = 1\text{ MHz}$	25°C		17		pF
C_{SON} C_{DON}	On capacitance	$f = 1\text{ MHz}$	25°C		20		pF

7.6 Electrical Characteristics ($V_{DD} = 3.3\text{ V} \pm 10\%$)

 at $T_A = 25^\circ\text{C}$, $V_{DD} = 3.3\text{ V}$ (unless otherwise noted)

PARAMETER		TEST CONDITIONS	TA	MIN	TYP	MAX	UNIT	
ANALOG SWITCH								
R_{ON}	On-resistance	$V_S = 0\text{ V to }V_{DD}$ $I_{SD} = 10\text{ mA}$ Refer to On-Resistance	25°C		3.7	8.8	Ω	
			–40°C to +85°C			9.5	Ω	
			–40°C to +125°C			9.8	Ω	
ΔR_{ON}	On-resistance matching between channels	$V_S = 0\text{ V to }V_{DD}$ $I_{SD} = 10\text{ mA}$ Refer to On-Resistance	25°C		0.13		Ω	
			–40°C to +85°C			0.4	Ω	
			–40°C to +125°C			0.5	Ω	
$R_{ON\text{ FLAT}}$	On-resistance flatness	$V_S = 0\text{ V to }V_{DD}$ $I_{SD} = 10\text{ mA}$ Refer to On-Resistance	25°C		1.9		Ω	
			–40°C to +85°C			2	Ω	
			–40°C to +125°C			2.2	Ω	
$I_{S(OFF)}$	Source off leakage current ⁽¹⁾	$V_{DD} = 3.3\text{ V}$ Switch Off $V_D = 3\text{ V} / 1\text{ V}$ $V_S = 1\text{ V} / 3\text{ V}$ Refer to Off-Leakage Current	25°C	–0.05	± 0.001	0.05	nA	
			–40°C to +85°C		–0.1		0.1	nA
			–40°C to +125°C		–0.7		0.7	nA
$I_{D(OFF)}$	Drain off leakage current ⁽¹⁾ (TMUX1133 Only)	$V_{DD} = 3.3\text{ V}$ Switch Off $V_D = 3\text{ V} / 1\text{ V}$ $V_S = 1\text{ V} / 3\text{ V}$ Refer to Off-Leakage Current	25°C	–0.1	± 0.005	0.1	nA	
			–40°C to +85°C		–0.35		0.35	nA
			–40°C to +125°C		–2		2	nA
$I_{D(ON)}$ $I_{S(ON)}$	Channel on leakage current	$V_{DD} = 3.3\text{ V}$ Switch On $V_D = V_S = 3\text{ V} / 1\text{ V}$ Refer to On-Leakage Current	25°C	–0.1	± 0.005	0.1	nA	
			–40°C to +85°C		–0.35		0.35	nA
			–40°C to +125°C		–2		2	nA
LOGIC INPUTS (\overline{EN}, SELx)								
V_{IH}	Input logic high		–40°C to +125°C	1.35		5.5	V	
V_{IL}	Input logic low						0	0.8
I_{IH} I_{IL}	Input leakage current		25°C		± 0.005		μA	
I_{IH} I_{IL}	Input leakage current		–40°C to +125°C			± 0.05	μA	
C_{IN}	Logic input capacitance		25°C		1		pF	
			–40°C to +125°C			2	pF	
POWER SUPPLY								
I_{DD}	V_{DD} supply current	Logic inputs = 0 V or 5.5 V	25°C		0.006		μA	
			–40°C to +125°C			1	μA	

 (1) When V_S is 3 V, V_D is 1 V or when V_S is 1 V, V_D is 3 V.

Electrical Characteristics ($V_{DD} = 3.3\text{ V} \pm 10\%$) (continued)

at $T_A = 25^\circ\text{C}$, $V_{DD} = 3.3\text{ V}$ (unless otherwise noted)

PARAMETER		TEST CONDITIONS	TA	MIN	TYP	MAX	UNIT
DYNAMIC CHARACTERISTICS							
t_{TRAN}	Transition time between channels	$V_S = 2\text{ V}$ $R_L = 200\ \Omega$, $C_L = 15\text{ pF}$ Refer to Transition Time	25°C	14			ns
			–40°C to +85°C			22	ns
			–40°C to +125°C			22	ns
t_{OPEN} (BBM)	Break before make time	$V_S = 2\text{ V}$ $R_L = 200\ \Omega$, $C_L = 15\text{ pF}$ Refer to Break-Before-Make	25°C	9			ns
			–40°C to +85°C	1			ns
			–40°C to +125°C	1			ns
$t_{\text{ON(EN)}}$	Enable turn-on time (TMUX1133 Only)	$V_S = 2\text{ V}$ $R_L = 200\ \Omega$, $C_L = 15\text{ pF}$ Refer to $t_{\text{ON(EN)}}$ and $t_{\text{OFF(EN)}}$	25°C	15			ns
			–40°C to +85°C			22	ns
			–40°C to +125°C			23	ns
$t_{\text{OFF(EN)}}$	Enable turn-off time (TMUX1133 Only)	$V_S = 2\text{ V}$ $R_L = 200\ \Omega$, $C_L = 15\text{ pF}$ Refer to $t_{\text{ON(EN)}}$ and $t_{\text{OFF(EN)}}$	25°C	8			ns
			–40°C to +85°C			13	ns
			–40°C to +125°C			14	ns
Q_C	Charge Injection	$V_S = 1\text{ V}$ $R_S = 0\ \Omega$, $C_L = 1\text{ nF}$ Refer to Charge Injection	25°C		–1		pC
O_{ISO}	Off Isolation	$R_L = 50\ \Omega$, $C_L = 5\text{ pF}$ $f = 1\text{ MHz}$ Refer to Off Isolation	25°C		–65		dB
		$R_L = 50\ \Omega$, $C_L = 5\text{ pF}$ $f = 10\text{ MHz}$ Refer to Off Isolation	25°C		–45		dB
X_{TALK}	Crosstalk	$R_L = 50\ \Omega$, $C_L = 5\text{ pF}$ $f = 1\text{ MHz}$ Refer to Crosstalk	25°C		–100		dB
		$R_L = 50\ \Omega$, $C_L = 5\text{ pF}$ $f = 10\text{ MHz}$ Refer to Crosstalk	25°C		–90		dB
BW	Bandwidth	$R_L = 50\ \Omega$, $C_L = 5\text{ pF}$ Refer to Bandwidth	25°C		220		MHz
C_{SOFF}	Source off capacitance	$f = 1\text{ MHz}$	25°C		6		pF
C_{DOFF}	Drain off capacitance	$f = 1\text{ MHz}$	25°C		17		pF
C_{SON} C_{DON}	On capacitance	$f = 1\text{ MHz}$	25°C		20		pF

7.7 Electrical Characteristics ($V_{DD} = 2.5\text{ V} \pm 10\%$), ($V_{SS} = -2.5\text{ V} \pm 10\%$)

 at $T_A = 25^\circ\text{C}$, $V_{DD} = +2.5\text{ V}$, $V_{SS} = -2.5\text{ V}$ (unless otherwise noted)

PARAMETER		TEST CONDITIONS	TA	MIN	TYP	MAX	UNIT
ANALOG SWITCH							
R_{ON}	On-resistance	$V_S = V_{SS}$ to V_{DD} $I_{SD} = 10\text{ mA}$ Refer to On-Resistance	25°C		2	4	Ω
			-40°C to +85°C			4.5	Ω
			-40°C to +125°C			4.9	Ω
ΔR_{ON}	On-resistance matching between channels	$V_S = V_{SS}$ to V_{DD} $I_{SD} = 10\text{ mA}$ Refer to On-Resistance	25°C		0.18		Ω
			-40°C to +85°C			0.4	Ω
			-40°C to +125°C			0.5	Ω
R_{ON} FLAT	On-resistance flatness	$V_S = V_{SS}$ to V_{DD} $I_{SD} = 10\text{ mA}$ Refer to On-Resistance	25°C		0.85		Ω
			-40°C to +85°C			1.6	Ω
			-40°C to +125°C			1.6	Ω
$I_{S(OFF)}$	Source off leakage current ⁽¹⁾	$V_{DD} = +2.5\text{ V}$, $V_{SS} = -2.5\text{ V}$ Switch Off $V_D = +2\text{ V} / -1\text{ V}$ $V_S = -1\text{ V} / +2\text{ V}$ Refer to Off-Leakage Current	25°C	-0.08	± 0.005	0.08	nA
			-40°C to +85°C		-0.3	0.3	nA
			-40°C to +125°C		-0.9	0.9	nA
$I_{D(OFF)}$	Drain off leakage current ⁽¹⁾	$V_{DD} = +2.5\text{ V}$, $V_{SS} = -2.5\text{ V}$ Switch Off $V_D = +2\text{ V} / -1\text{ V}$ $V_S = -1\text{ V} / +2\text{ V}$ Refer to Off-Leakage Current	25°C	-0.1	± 0.01	0.1	nA
			-40°C to +85°C		-0.35	0.35	nA
			-40°C to +125°C		-2	2	nA
$I_{D(ON)}$ $I_{S(ON)}$	Channel on leakage current	$V_{DD} = +2.5\text{ V}$, $V_{SS} = -2.5\text{ V}$ Switch On $V_D = V_S = +2\text{ V} / -1\text{ V}$ Refer to On-Leakage Current	25°C	-0.1	± 0.01	0.1	nA
			-40°C to +85°C		-0.35	0.35	nA
			-40°C to +125°C		-2	2	nA
LOGIC INPUTS (\overline{EN}, SELx)							
V_{IH}	Input logic high		-40°C to +125°C	1.2		2.75	V
V_{IL}	Input logic low		-40°C to +125°C	0		0.73	V
I_{IH} I_{IL}	Input leakage current		25°C		± 0.005		μA
I_{IH} I_{IL}	Input leakage current		-40°C to +125°C			± 0.05	μA
C_{IN}	Logic input capacitance		25°C		1		pF
			-40°C to +125°C			2	pF
POWER SUPPLY							
I_{DD}	V_{DD} supply current	Logic inputs = 0 V or 2.75 V	25°C		0.008		μA
			-40°C to +125°C			1	μA
I_{SS}	V_{SS} supply current	Logic inputs = 0 V or 2.75 V	25°C		0.008		μA
			-40°C to +125°C			1	μA

 (1) When V_S is positive, V_D is negative or when V_S is negative, V_D is positive.

Electrical Characteristics ($V_{DD} = 2.5\text{ V} \pm 10\%$), ($V_{SS} = -2.5\text{ V} \pm 10\%$) (continued)

at $T_A = 25^\circ\text{C}$, $V_{DD} = +2.5\text{ V}$, $V_{SS} = -2.5\text{ V}$ (unless otherwise noted)

PARAMETER		TEST CONDITIONS	TA	MIN	TYP	MAX	UNIT
DYNAMIC CHARACTERISTICS							
t_{TRAN}	Transition time between channels	$V_S = 1.5\text{ V}$ $R_L = 200\ \Omega$, $C_L = 15\text{ pF}$ Refer to Transition Time	25°C	12			ns
			-40°C to +85°C			20	ns
			-40°C to +125°C			21	ns
t_{OPEN} (BBM)	Break before make time	$V_S = 1.5\text{ V}$ $R_L = 200\ \Omega$, $C_L = 15\text{ pF}$ Refer to Break-Before-Make	25°C	8			ns
			-40°C to +85°C	1			ns
			-40°C to +125°C	1			ns
$t_{\text{ON(EN)}}$	Enable turn-on time (TMUX1133 Only)	$V_S = 1.5\text{ V}$ $R_L = 200\ \Omega$, $C_L = 15\text{ pF}$ Refer to $t_{\text{ON(EN)}}$ and $t_{\text{OFF(EN)}}$	25°C	12			ns
			-40°C to +85°C			21	ns
			-40°C to +125°C			22	ns
$t_{\text{OFF(EN)}}$	Enable turn-off time (TMUX1133 Only)	$V_S = 1.5\text{ V}$ $R_L = 200\ \Omega$, $C_L = 15\text{ pF}$ Refer to $t_{\text{ON(EN)}}$ and $t_{\text{OFF(EN)}}$	25°C	6			ns
			-40°C to +85°C			14	ns
			-40°C to +125°C			15	ns
Q_C	Charge Injection	$V_S = -1\text{ V}$ $R_S = 0\ \Omega$, $C_L = 1\text{ nF}$ Refer to Charge Injection	25°C		-1		pC
O_{ISO}	Off Isolation	$R_L = 50\ \Omega$, $C_L = 5\text{ pF}$ $f = 1\text{ MHz}$ Refer to Off Isolation	25°C		-65		dB
		$R_L = 50\ \Omega$, $C_L = 5\text{ pF}$ $f = 10\text{ MHz}$ Refer to Off Isolation	25°C		-45		dB
X_{TALK}	Crosstalk	$R_L = 50\ \Omega$, $C_L = 5\text{ pF}$ $f = 1\text{ MHz}$ Refer to Crosstalk	25°C		-100		dB
		$R_L = 50\ \Omega$, $C_L = 5\text{ pF}$ $f = 10\text{ MHz}$ Refer to Crosstalk	25°C		-90		dB
BW	Bandwidth	$R_L = 50\ \Omega$, $C_L = 5\text{ pF}$ Refer to Bandwidth	25°C		220		MHz
C_{SOFF}	Source off capacitance	$f = 1\text{ MHz}$	25°C		6		pF
C_{DOFF}	Drain off capacitance	$f = 1\text{ MHz}$	25°C		17		pF
C_{SON} C_{DON}	On capacitance	$f = 1\text{ MHz}$	25°C		20		pF

7.8 Electrical Characteristics ($V_{DD} = 1.8\text{ V} \pm 10\%$)

 at $T_A = 25^\circ\text{C}$, $V_{DD} = 1.8\text{ V}$ (unless otherwise noted)

PARAMETER		TEST CONDITIONS	TA	MIN	TYP	MAX	UNIT
ANALOG SWITCH							
R_{ON}	On-resistance	$V_S = 0\text{ V to }V_{DD}$ $I_{SD} = 10\text{ mA}$ Refer to On-Resistance	25°C	40			Ω
			–40°C to +85°C			80	Ω
			–40°C to +125°C			80	Ω
ΔR_{ON}	On-resistance matching between channels	$V_S = 0\text{ V to }V_{DD}$ $I_{SD} = 10\text{ mA}$ Refer to On-Resistance	25°C	0.4			Ω
			–40°C to +85°C			1.5	Ω
			–40°C to +125°C			1.5	Ω
$I_{S(OFF)}$	Source off leakage current ⁽¹⁾	$V_{DD} = 1.98\text{ V}$ Switch Off $V_D = 1.62\text{ V} / 1\text{ V}$ $V_S = 1\text{ V} / 1.62\text{ V}$ Refer to Off-Leakage Current	25°C	–0.05	± 0.003	0.05	nA
			–40°C to +85°C	–0.1		0.1	nA
			–40°C to +125°C	–0.5		0.5	nA
$I_{D(OFF)}$	Drain off leakage current ⁽¹⁾	$V_{DD} = 1.98\text{ V}$ Switch Off $V_D = 1.62\text{ V} / 1\text{ V}$ $V_S = 1\text{ V} / 1.62\text{ V}$ Refer to Off-Leakage Current	25°C	–0.1	± 0.005	0.1	nA
			–40°C to +85°C	–0.5		0.5	nA
			–40°C to +125°C	–2		2	nA
$I_{D(ON)}$ $I_{S(ON)}$	Channel on leakage current	$V_{DD} = 1.98\text{ V}$ Switch On $V_D = V_S = 1.62\text{ V} / 1\text{ V}$ Refer to On-Leakage Current	25°C	–0.1	± 0.005	0.1	nA
			–40°C to +85°C	–0.5		0.5	nA
			–40°C to +125°C	–2		2	nA
LOGIC INPUTS (\overline{EN}, SELx)							
V_{IH}	Input logic high		–40°C to +125°C	1.07		5.5	V
V_{IL}	Input logic low			0		0.68	V
I_{IH} I_{IL}	Input leakage current		25°C	± 0.005			μA
I_{IH} I_{IL}	Input leakage current		–40°C to +125°C			± 0.05	μA
C_{IN}	Logic input capacitance		25°C	1			pF
			–40°C to +125°C			2	pF
POWER SUPPLY							
I_{DD}	V_{DD} supply current	Logic inputs = 0 V or 5.5 V	25°C	0.001			μA
			–40°C to +125°C			0.85	μA

 (1) When V_S is 1.62 V, V_D is 1 V or when V_S is 1 V, V_D is 1.62 V.

Electrical Characteristics ($V_{DD} = 1.8\text{ V} \pm 10\%$) (continued)

at $T_A = 25^\circ\text{C}$, $V_{DD} = 1.8\text{ V}$ (unless otherwise noted)

PARAMETER		TEST CONDITIONS	TA	MIN	TYP	MAX	UNIT
DYNAMIC CHARACTERISTICS							
t_{TRAN}	Transition time between channels	$V_S = 1\text{ V}$ $R_L = 200\ \Omega$, $C_L = 15\text{ pF}$ Refer to Transition Time	25°C	28			ns
			–40°C to +85°C			48	ns
			–40°C to +125°C			48	ns
t_{OPEN} (BBM)	Break before make time	$V_S = 1\text{ V}$ $R_L = 200\ \Omega$, $C_L = 15\text{ pF}$ Refer to Break-Before-Make	25°C	16			ns
			–40°C to +85°C	1			ns
			–40°C to +125°C	1			ns
$t_{\text{ON(EN)}}$	Enable turn-on time (TMUX1133 Only)	$V_S = 1\text{ V}$ $R_L = 200\ \Omega$, $C_L = 15\text{ pF}$ Refer to $t_{\text{ON(EN)}}$ and $t_{\text{OFF(EN)}}$	25°C	28			ns
			–40°C to +85°C			48	ns
			–40°C to +125°C			48	ns
$t_{\text{OFF(EN)}}$	Enable turn-off time (TMUX1133 Only)	$V_S = 1\text{ V}$ $R_L = 200\ \Omega$, $C_L = 15\text{ pF}$ Refer to $t_{\text{ON(EN)}}$ and $t_{\text{OFF(EN)}}$	25°C	16			ns
			–40°C to +85°C			27	ns
			–40°C to +125°C			27	ns
Q_C	Charge Injection	$V_S = 1\text{ V}$ $R_S = 0\ \Omega$, $C_L = 1\text{ nF}$ Refer to Charge Injection	25°C		–1		pC
O_{ISO}	Off Isolation	$R_L = 50\ \Omega$, $C_L = 5\text{ pF}$ $f = 1\text{ MHz}$ Refer to Off Isolation	25°C		–65		dB
		$R_L = 50\ \Omega$, $C_L = 5\text{ pF}$ $f = 10\text{ MHz}$ Refer to Off Isolation	25°C		–45		dB
X_{TALK}	Crosstalk	$R_L = 50\ \Omega$, $C_L = 5\text{ pF}$ $f = 1\text{ MHz}$ Refer to Crosstalk	25°C		–100		dB
		$R_L = 50\ \Omega$, $C_L = 5\text{ pF}$ $f = 10\text{ MHz}$ Refer to Crosstalk	25°C		–90		dB
BW	Bandwidth	$R_L = 50\ \Omega$, $C_L = 5\text{ pF}$ Refer to Bandwidth	25°C		220		MHz
C_{SOFF}	Source off capacitance	$f = 1\text{ MHz}$	25°C		6		pF
C_{DOFF}	Drain off capacitance	$f = 1\text{ MHz}$	25°C		17		pF
C_{SON} C_{DON}	On capacitance	$f = 1\text{ MHz}$	25°C		20		pF

7.9 Electrical Characteristics ($V_{DD} = 1.2\text{ V} \pm 10\%$)

PARAMETER		TEST CONDITIONS	TA	MIN	TYP	MAX	UNIT
ANALOG SWITCH							
R_{ON}	On-resistance	$V_S = 0\text{ V to }V_{DD}$ $I_{SD} = 10\text{ mA}$ Refer to On-Resistance	25°C	70			Ω
			-40°C to +85°C			105	Ω
			-40°C to +125°C			105	Ω
ΔR_{ON}	On-resistance matching between channels	$V_S = 0\text{ V to }V_{DD}$ $I_{SD} = 10\text{ mA}$ Refer to On-Resistance	25°C	0.4			Ω
			-40°C to +85°C			1.5	Ω
			-40°C to +125°C			1.5	Ω
$I_{S(OFF)}$	Source off leakage current ⁽¹⁾	$V_{DD} = 1.32\text{ V}$ Switch Off $V_D = 1\text{ V} / 0.8\text{ V}$ $V_S = 0.8\text{ V} / 1\text{ V}$ Refer to Off-Leakage Current	25°C	-0.05	± 0.003	0.05	nA
			-40°C to +85°C	-0.1		0.1	nA
			-40°C to +125°C	-0.5		0.5	nA
$I_{D(OFF)}$	Drain off leakage current ⁽¹⁾	$V_{DD} = 1.32\text{ V}$ Switch Off $V_D = 1\text{ V} / 0.8\text{ V}$ $V_S = 0.8\text{ V} / 1\text{ V}$ Refer to Off-Leakage Current	25°C	-0.1	± 0.005	0.1	nA
			-40°C to +85°C	-0.5		0.5	nA
			-40°C to +125°C	-2		2	nA
$I_{D(ON)}$ $I_{S(ON)}$	Channel on leakage current	$V_{DD} = 1.32\text{ V}$ Switch On $V_D = V_S = 1\text{ V} / 0.8\text{ V}$ Refer to On-Leakage Current	25°C	-0.1	± 0.005	0.1	nA
			-40°C to +85°C	-0.5		0.5	nA
			-40°C to +125°C	-2		2	nA
LOGIC INPUTS (\overline{EN}, SELx)							
V_{IH}	Input logic high		-40°C to +125°C	0.96		5.5	V
V_{IL}	Input logic low		-40°C to +125°C	0		0.36	V
I_{IH} I_{IL}	Input leakage current		25°C	± 0.005			μA
I_{IH} I_{IL}	Input leakage current		-40°C to +125°C			± 0.05	μA
C_{IN}	Logic input capacitance		25°C	1			pF
			-40°C to +125°C			2	pF
POWER SUPPLY							
I_{DD}	V_{DD} supply current	Logic inputs = 0 V or 5.5 V	25°C	0.001			μA
			-40°C to +125°C			0.7	μA

(1) When V_S is 1 V, V_D is 0.8 V or when V_S is 0.8 V, V_D is 1 V.

Electrical Characteristics ($V_{DD} = 1.2\text{ V} \pm 10\%$) (continued)

PARAMETER		TEST CONDITIONS	TA	MIN	TYP	MAX	UNIT
DYNAMIC CHARACTERISTICS							
t_{TRAN}	Transition time between channels	$V_S = 1\text{ V}$ $R_L = 200\ \Omega$, $C_L = 15\text{ pF}$ Refer to Transition Time	25°C	55			ns
			–40°C to +85°C			201	ns
			–40°C to +125°C			201	ns
t_{OPEN} (BBM)	Break before make time	$V_S = 1\text{ V}$ $R_L = 200\ \Omega$, $C_L = 15\text{ pF}$ Refer to Break-Before-Make	25°C	28			ns
			–40°C to +85°C	1			ns
			–40°C to +125°C	1			ns
$t_{\text{ON(EN)}}$	Enable turn-on time (TMUX1133 Only)	$V_S = 1\text{ V}$ $R_L = 200\ \Omega$, $C_L = 15\text{ pF}$ Refer to $t_{\text{ON(EN)}}$ and $t_{\text{OFF(EN)}}$	25°C	60			ns
			–40°C to +85°C			201	ns
			–40°C to +125°C			201	ns
$t_{\text{OFF(EN)}}$	Enable turn-off time (TMUX1133 Only)	$V_S = 1\text{ V}$ $R_L = 200\ \Omega$, $C_L = 15\text{ pF}$ Refer to $t_{\text{ON(EN)}}$ and $t_{\text{OFF(EN)}}$	25°C	45			ns
			–40°C to +85°C			150	ns
			–40°C to +125°C			150	ns
Q_C	Charge Injection	$V_S = 1\text{ V}$ $R_S = 0\ \Omega$, $C_L = 1\text{ nF}$ Refer to Charge Injection	25°C	–1			pC
O_{ISO}	Off Isolation	$R_L = 50\ \Omega$, $C_L = 5\text{ pF}$ $f = 1\text{ MHz}$ Refer to Off Isolation	25°C	–65			dB
		$R_L = 50\ \Omega$, $C_L = 5\text{ pF}$ $f = 10\text{ MHz}$ Refer to Off Isolation	25°C	–45			dB
X_{TALK}	Crosstalk	$R_L = 50\ \Omega$, $C_L = 5\text{ pF}$ $f = 1\text{ MHz}$ Refer to Crosstalk	25°C	–100			dB
		$R_L = 50\ \Omega$, $C_L = 5\text{ pF}$ $f = 10\text{ MHz}$ Refer to Crosstalk	25°C	–90			dB
BW	Bandwidth	$R_L = 50\ \Omega$, $C_L = 5\text{ pF}$ Refer to Bandwidth	25°C	220			MHz
C_{SOFF}	Source off capacitance	$f = 1\text{ MHz}$	25°C	6			pF
C_{DOFF}	Drain off capacitance	$f = 1\text{ MHz}$	25°C	17			pF
C_{SON} C_{DON}	On capacitance	$f = 1\text{ MHz}$	25°C	20			pF

7.10 Typical Characteristics

at $T_A = 25^\circ\text{C}$, $V_{DD} = 5\text{ V}$ (unless otherwise noted)

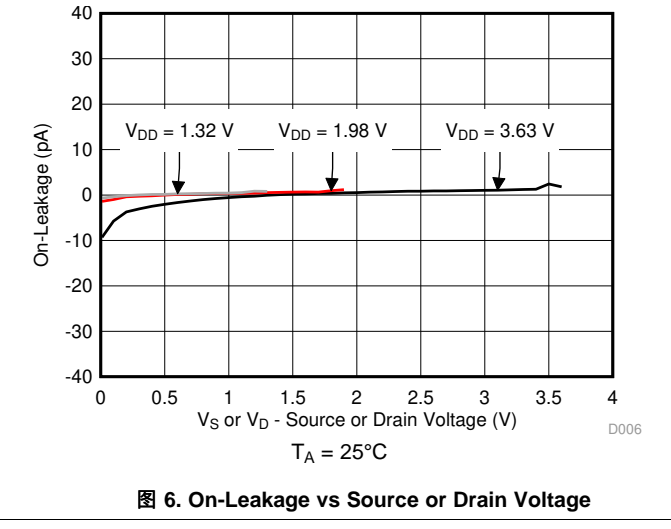
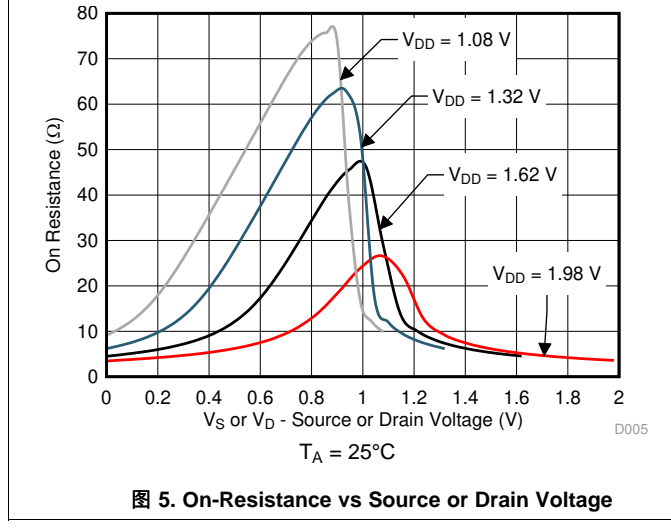
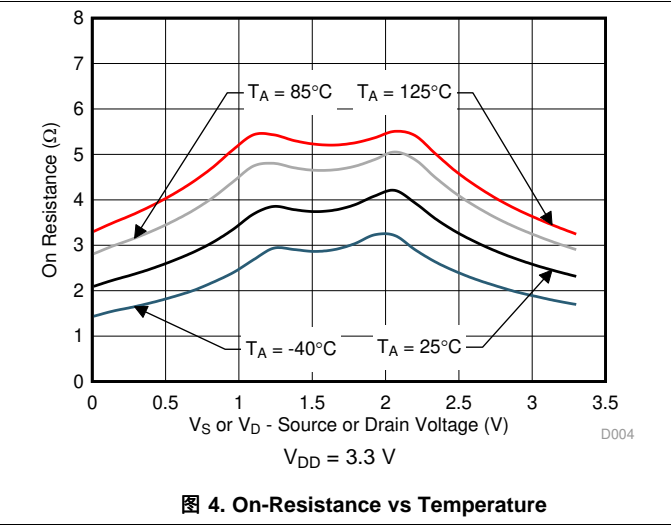
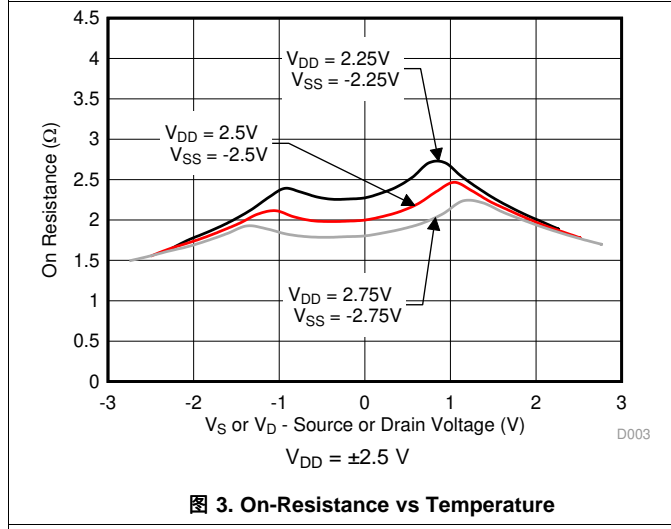
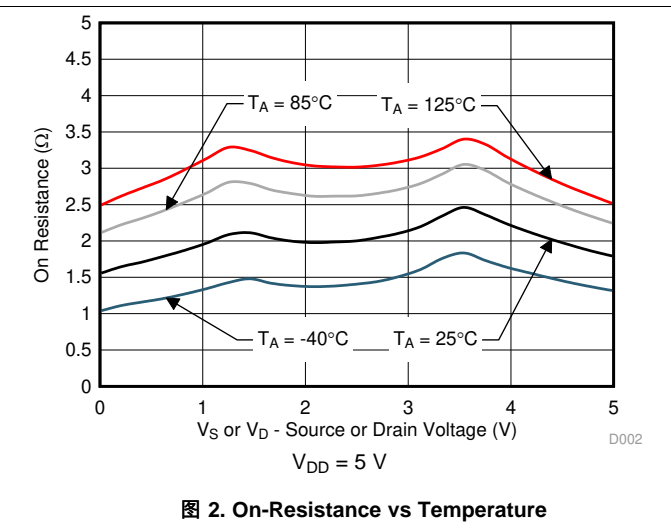
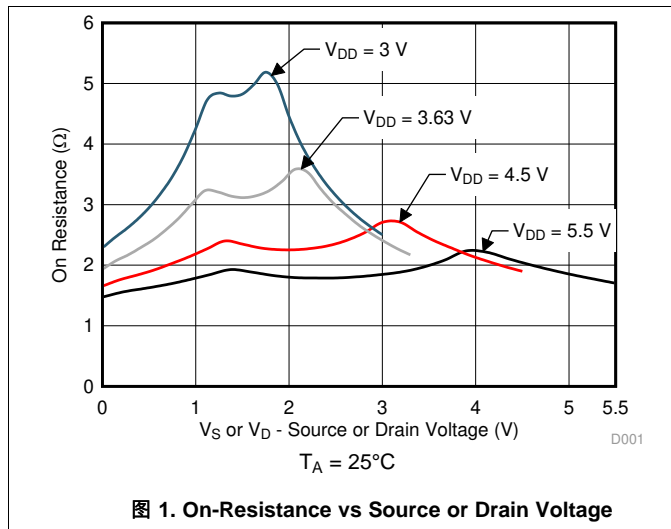

Typical Characteristics (接下页)



图 7. On-Leakage vs Source or Drain Voltage



图 8. Leakage Current vs Temperature

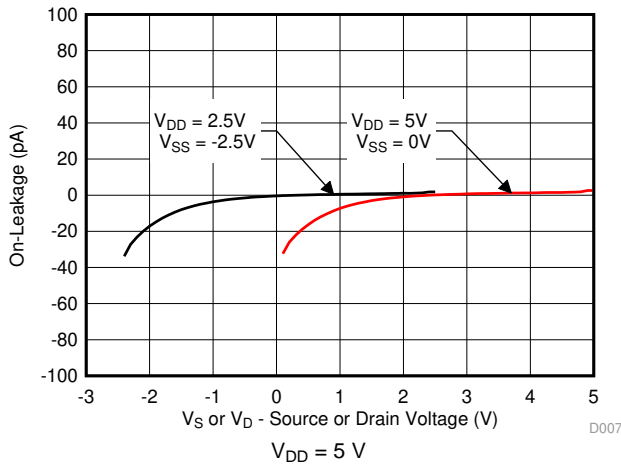

图 9. Leakage Current vs Temperature

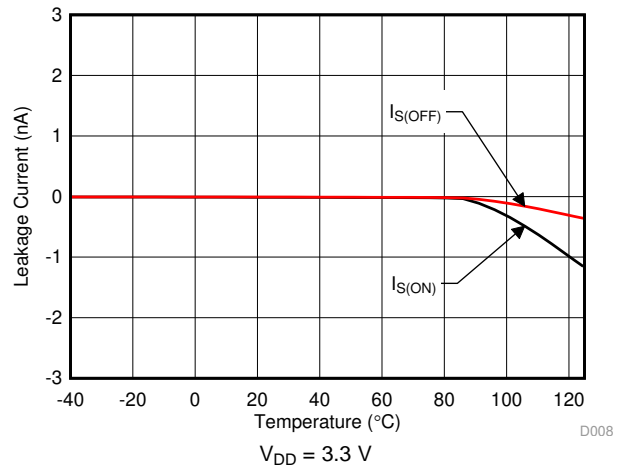

图 10. Supply Current vs Temperature

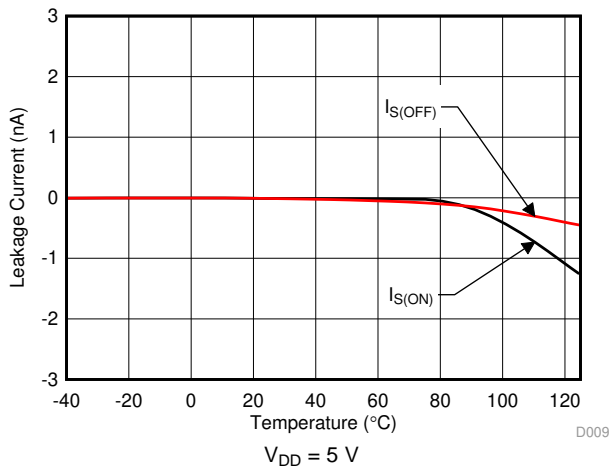

图 11. Supply Current vs Logic Voltage

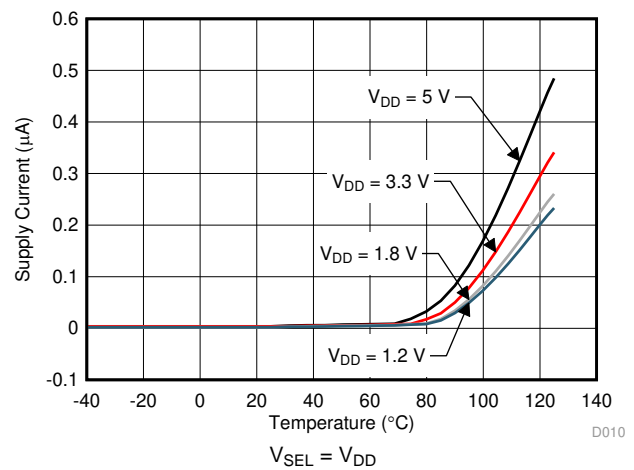

图 12. Charge Injection vs Source Voltage

Typical Characteristics (接下页)

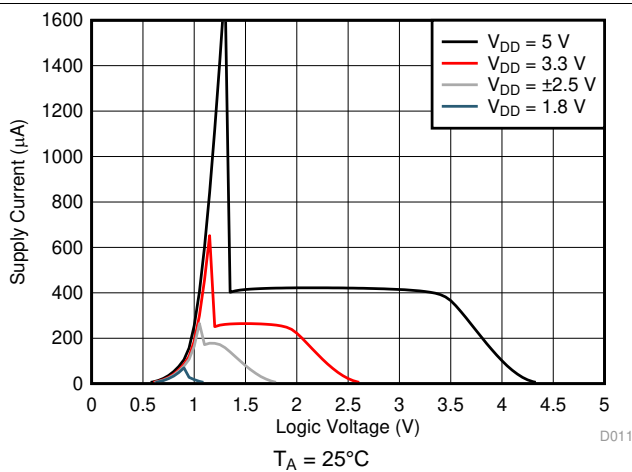

图 13. Charge Injection vs Source Voltage

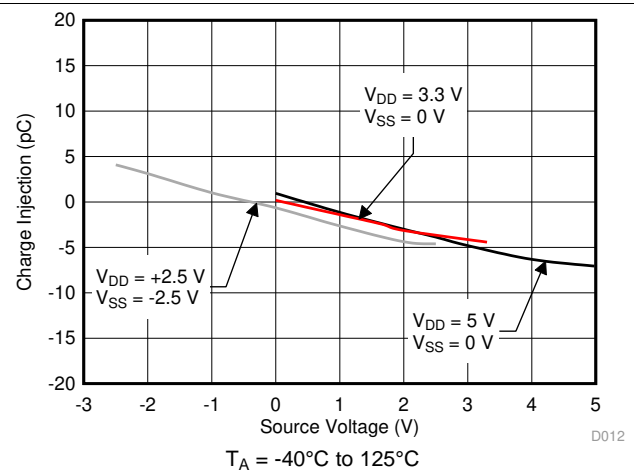

图 14. Xtalk and Off-Isolation vs Frequency

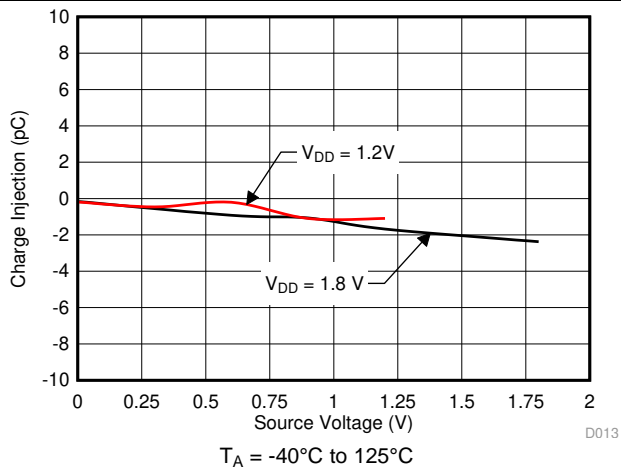

图 15. On Response vs Frequency

8 Parameter Measurement Information

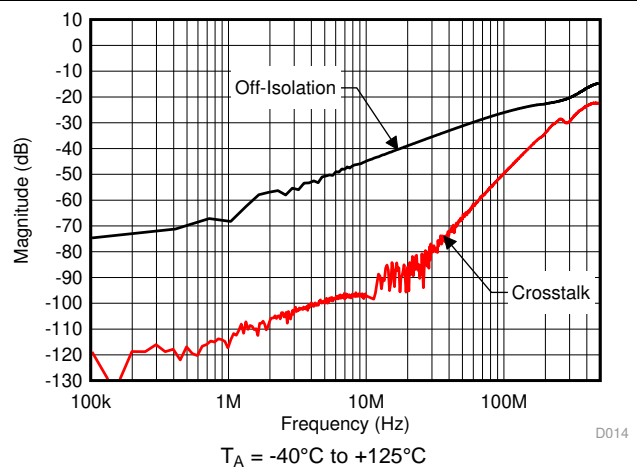
8.1 On-Resistance

The on-resistance of a device is the ohmic resistance between the source (Sx) and drain (Dx) pins of the device. The on-resistance varies with input voltage and supply voltage. The symbol R_{ON} is used to denote on-resistance. The measurement setup used to measure R_{ON} is shown in [图 16](#). Voltage (V) and current (I_{SD}) are measured using this setup, and R_{ON} is computed with $R_{ON} = V / I_{SD}$:

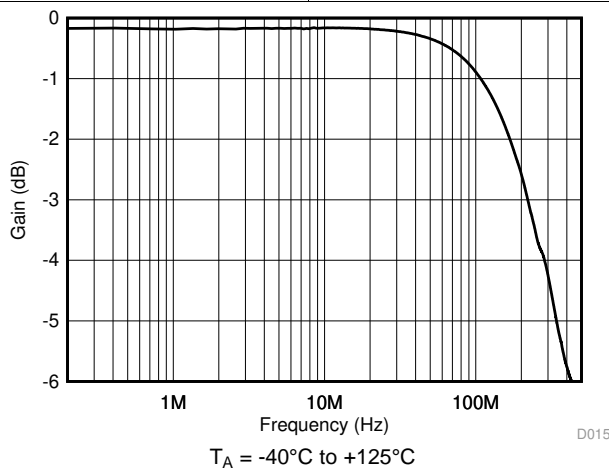

图 16. On-Resistance Measurement Setup

8.2 Off-Leakage Current

There are two types of leakage currents associated with a switch during the off state:

1. Source off-leakage current
2. Drain off-leakage current

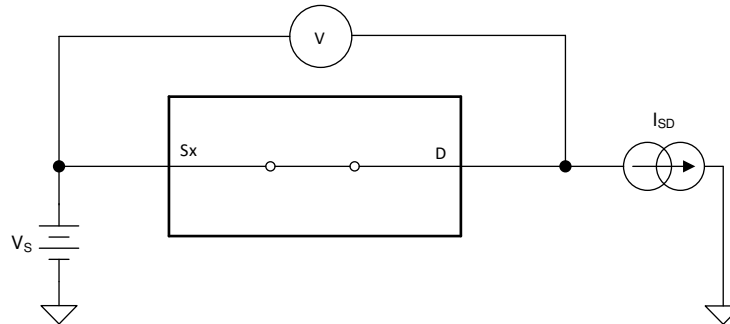
Source leakage current is defined as the leakage current flowing into or out of the source pin when the switch is off. This current is denoted by the symbol $I_{S(OFF)}$.

Drain leakage current is defined as the leakage current flowing into or out of the drain pin when the switch is off. This current is denoted by the symbol $I_{D(OFF)}$.

The setup used to measure both off-leakage currents is shown in [图 17](#).



图 17. Off-Leakage Measurement Setup

8.3 On-Leakage Current

Source on-leakage current is defined as the leakage current flowing into or out of the source pin when the switch is on. This current is denoted by the symbol $I_{S(ON)}$.

Drain on-leakage current is defined as the leakage current flowing into or out of the drain pin when the switch is on. This current is denoted by the symbol $I_{D(ON)}$.

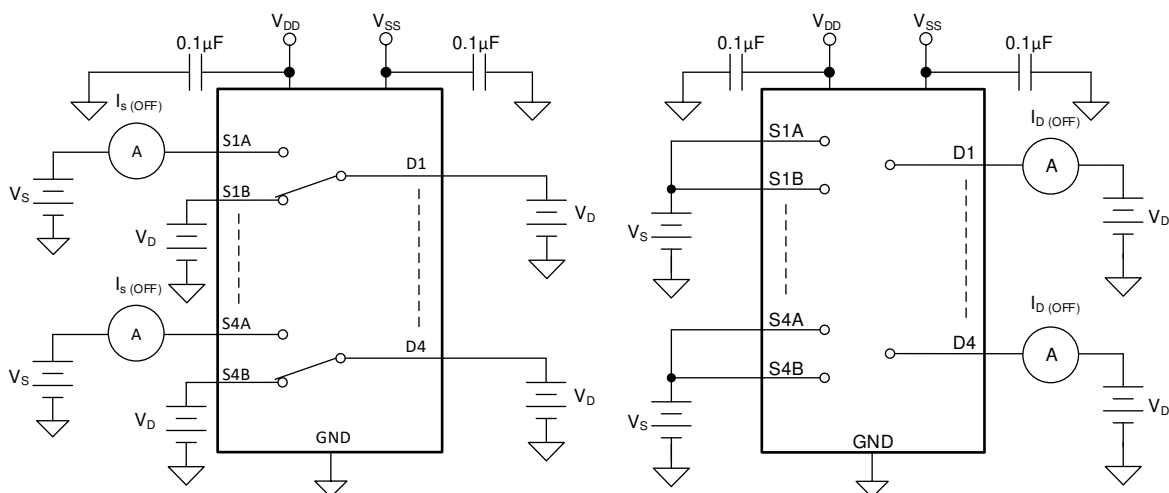
Either the source pin or drain pin is left floating during the measurement. 图 18 shows the circuit used for measuring the on-leakage current, denoted by $I_{S(ON)}$ or $I_{D(ON)}$.



图 18. On-Leakage Measurement Setup

8.4 Transition Time

Transition time is defined as the time taken by the output of the device to rise or fall 10% after the address signal has risen or fallen past the logic threshold. The 10% transition measurement is utilized to provide the timing of the device. System level timing can then account for the time constant added from the load resistance and load capacitance. 图 19 shows the setup used to measure transition time, denoted by the symbol $t_{TRANSITION}$.

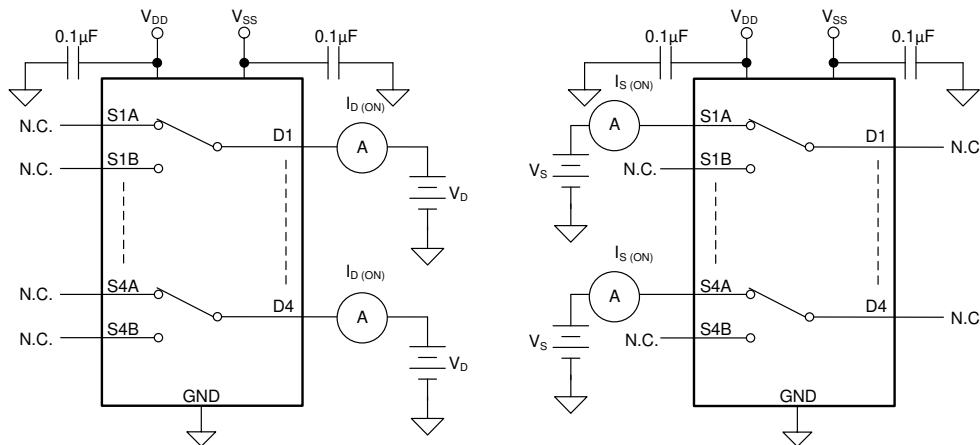

图 19. Transition-Time Measurement Setup

8.5 Break-Before-Make

Break-before-make delay is a safety feature that prevents two inputs from connecting when the device is switching. The output first breaks from the on-state switch before making the connection with the next on-state switch. The time delay between the *break* and the *make* is known as break-before-make delay. 图 20 shows the setup used to measure break-before-make delay, denoted by the symbol $t_{OPEN(BBM)}$.

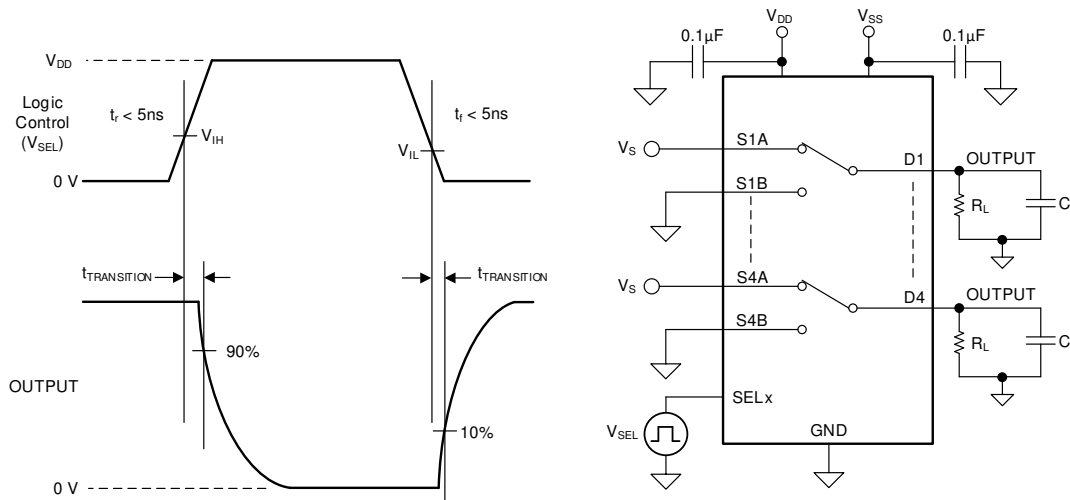

图 20. Break-Before-Make Delay Measurement Setup

8.6 $t_{ON(EN)}$ and $t_{OFF(EN)}$

Turn-on time is defined as the time taken by the output of the device to rise to 10% after the enable has risen past the logic threshold. The 10% measurement is utilized to provide the timing of the device. System level timing can then account for the time constant added from the load resistance and load capacitance. 图 21 shows the setup used to measure turn-on time, denoted by the symbol $t_{ON(EN)}$.

Turn-off time is defined as the time taken by the output of the device to fall to 90% after the enable has fallen past the logic threshold. The 90% measurement is utilized to provide the timing of the device. System level timing can then account for the time constant added from the load resistance and load capacitance. 图 21 shows the setup used to measure turn-off time, denoted by the symbol $t_{OFF(EN)}$.

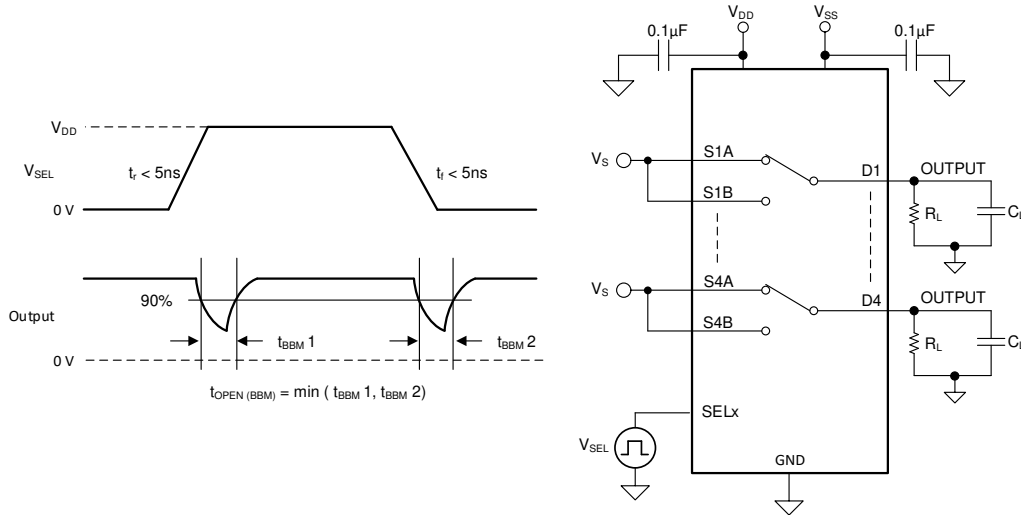

图 21. Turn-On and Turn-Off Time Measurement Setup

8.7 Charge Injection

The TMUX1133 has a transmission-gate topology. Any mismatch in capacitance between the NMOS and PMOS transistors results in a charge injected into the drain or source during the falling or rising edge of the gate signal. The amount of charge injected into the source or drain of the device is known as charge injection, and is denoted by the symbol Q_C . 图 22 shows the setup used to measure charge injection from source (Sx) to drain (D).

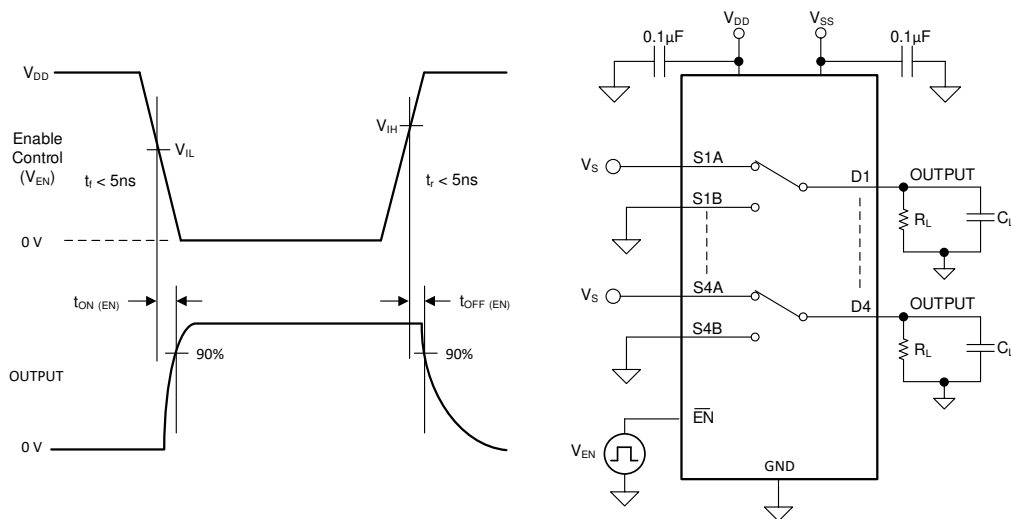

图 22. Charge-Injection Measurement Setup

8.8 Off Isolation

Off isolation is defined as the ratio of the signal at the drain pin (D) of the device when a signal is applied to the source pin (Sx) of an off-channel. 图 23 shows the setup used to measure, and the equation used to calculate off isolation.

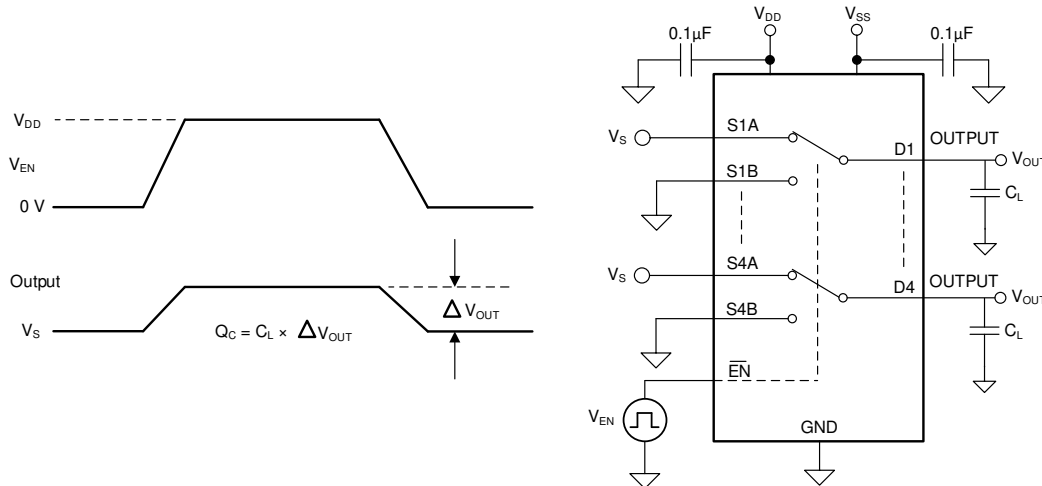

图 23. Off Isolation Measurement Setup

$$\text{Off Isolation} = 20 \cdot \text{Log} \left(\frac{V_{\text{OUT}}}{V_{\text{S}}} \right)$$

(1)

8.9 Crosstalk

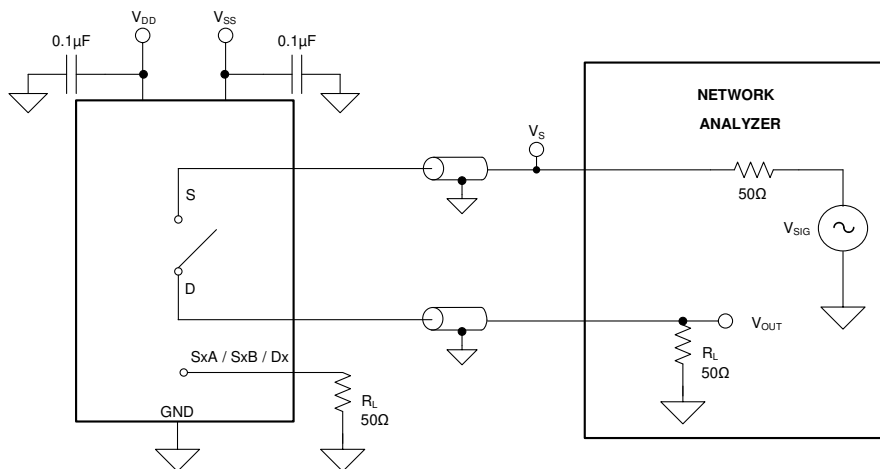
Crosstalk is defined as the ratio of the signal at the drain pin (D) of a different channel, when a signal is applied at the source pin (Sx) of an on-channel. 图 24 shows the setup used to measure, and the equation used to calculate crosstalk.



图 24. Crosstalk Measurement Setup

$$\text{Channel-to-Channel Crosstalk} = 20 \cdot \text{Log} \left(\frac{V_{OUT}}{V_S} \right) \quad (2)$$

8.10 Bandwidth

Bandwidth is defined as the range of frequencies that are attenuated by less than 3 dB when the input is applied to the source pin (Sx) of an on-channel, and the output is measured at the drain pin (D) of the device. 图 25 shows the setup used to measure bandwidth.

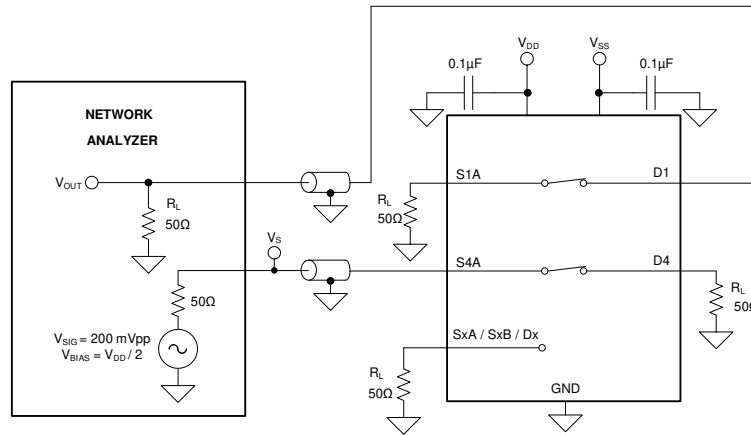

图 25. Bandwidth Measurement Setup

9 Detailed Description

9.1 Overview

The TMUX1133 contains three independently controlled single-pole double-throw (SPDT) switches and has an active low $\overline{\text{EN}}$ pin to enable or disable all three switches simultaneously. The TMUX1134 contains four independently controlled SPDT switches.

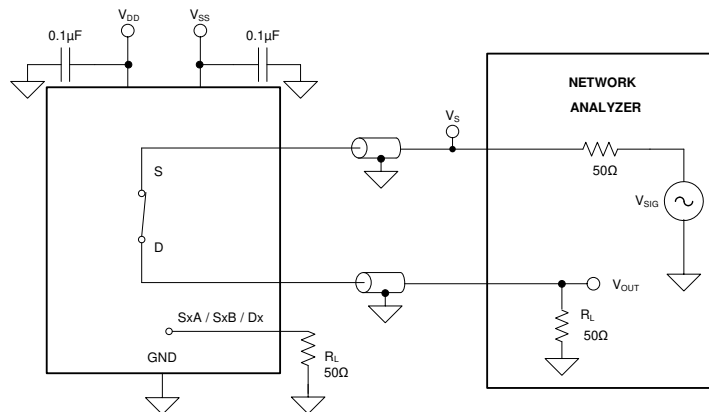
9.2 Functional Block Diagram



图 26. TMUX1133 Functional Block Diagram

9.3 Feature Description

9.3.1 Bidirectional Operation

The TMUX113x devices conduct equally well from source (S_x) to drain (D_x) or from drain (D_x) to source (S_x). Each channel has very similar characteristics in both directions and supports both analog and digital signals.

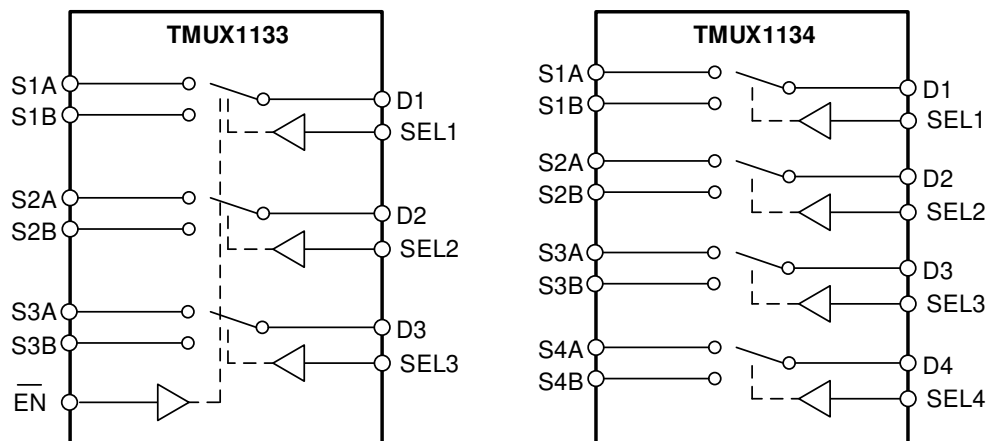
9.3.2 Rail to Rail Operation

The valid signal path input/output voltage for TMUX113x ranges from V_{SS} to V_{DD} . For single supply applications V_{SS} can be connected to GND.

9.3.3 1.8 V Logic Compatible Inputs

The TMUX113x devices have 1.8-V logic compatible control for all logic control inputs. The logic input thresholds scale with supply but still provide 1.8-V logic control when operating at 5.5 V supply voltage. 1.8-V logic level inputs allows the TMUX113x devices to interface with processors that have lower logic I/O rails and eliminates the need for an external translator, which saves both space and BOM cost. The current consumption of the TMUX113x devices increase when using 1.8V logic with higher supply voltage as shown in 图 11. For more information on 1.8 V logic implementations refer to [Simplifying Design with 1.8 V logic Muxes and Switches](#)

9.3.4 Fail-Safe Logic

The TMUX113x devices support Fail-Safe Logic on the control input pins (SEL_x and $\overline{\text{EN}}$) allowing for operation up to 5.5 V, regardless of the state of the supply pins. This feature allows voltages on the control pins to be applied before the supply pins, protecting the device from potential damage. Fail-Safe Logic minimizes system complexity by removing the need for power supply sequencing on the logic control pins. For example, the Fail-Safe Logic feature allows the select pins of the TMUX113x devices to be ramped to 5.5 V while $V_{DD} = 0$ V. Additionally, the feature enables operation of the TMUX113x devices with $V_{DD} = 1.2$ V while allowing the select pins to interface with a logic level of another device up to 5.5 V.

Feature Description (接下页)

9.3.5 Ultra-low Leakage Current

The TMUX1133 and TMUX1134 provide extremely low on-leakage and off-leakage currents. The TMUX113x devices are capable of switching signals from high source-impedance inputs into a high input-impedance op amp with minimal offset error because of the ultra-low leakage currents. 图 27 shows typical leakage currents of the TMUX113x devices versus input voltage.



图 27. Leakage Current vs Input Voltage

9.3.6 Ultra-low Charge Injection

The TMUX113x devices have a transmission gate topology, as shown in 图 28. Any mismatch in the stray capacitance associated with the NMOS and PMOS causes an output level change whenever the switch is opened or closed.

The TMUX113x devices have special charge-injection cancellation circuitry that reduces the source-to-drain charge injection to -1 pC at $V_S = 1\text{ V}$ as shown in 图 29.

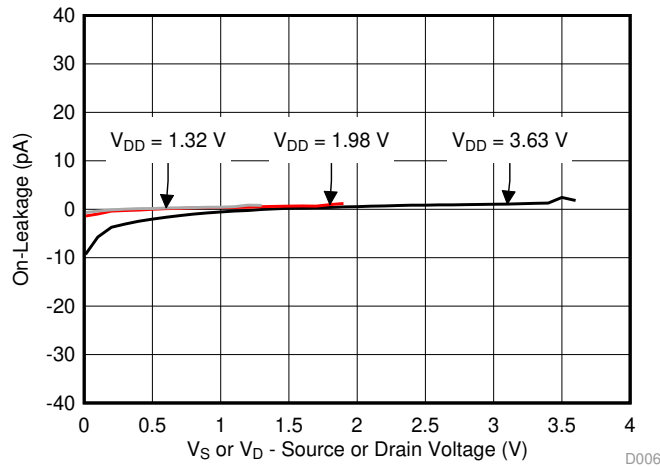

图 28. Transmission Gate Topology



图 29. Charge Injection vs Source Voltage

9.4 Device Functional Modes

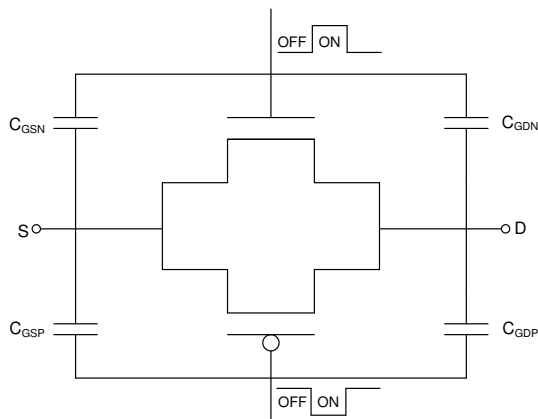
The select (SELx) pins are logic pins that control the connection between the source (SxA, SxB) and drain (Dx) pins of the TMUX113x devices. When a source pin is not selected that pin is in an open state (Hi-Z). When a source pin is selected the switch conducts to drain. The logic control pins can be as high as 5.5 V.

When the $\overline{\text{EN}}$ pin of the TMUX1133 is pulled low the SELx logic control inputs determine which source input is selected. When the $\overline{\text{EN}}$ pin is pulled high, all of the switches are in an open state regardless of the state of the SELx logic control inputs. The TMUX1134 SELx logic control inputs determine which source pin is connected to the drain pin for each channel.

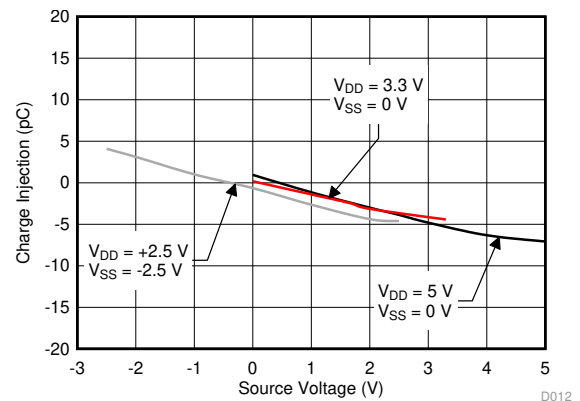
The TMUX113x devices can be operated without any external components except for the supply decoupling capacitors. Unused logic control pins must be tied to GND or V_{DD} in order to ensure the device does not consume additional current as highlighted in *Implications of Slow or Floating CMOS Inputs*. Unused signal path inputs (SxA, SxB or Dx) should be connected to GND.

9.5 Truth Tables

表 1 and 表 2 show the truth tables for the TMUX1133 and TMUX1134 respectively.

表 1. TMUX1133 Truth table⁽¹⁾

$\overline{\text{EN}}$	SEL1	SEL2	SEL3	Selected Source Pins Connected To Drain Pins
0	0	X	X	S1A to D1
0	1	X	X	S1B to D1
0	X	0	X	S2A to D2
0	X	1	X	S2B to D2
0	X	X	0	S3A to D3
0	X	X	1	S3B to D3
1	X	X	X	Hi-Z (OFF)

(1) X denotes *don't care*.

表 2. TMUX1134 Truth table⁽¹⁾

SEL1	SEL2	SEL3	SEL4	Selected Source Pins Connected To Drain Pins
0	X	X	X	S1B to D1
1	X	X	X	S1A to D1
X	0	X	X	S2B to D2
X	1	X	X	S2A to D2
X	X	0	X	S3B to D3
X	X	1	X	S3A to D3
X	X	X	0	S4B to D4
X	X	X	1	S4A to D4

(1) X denotes *don't care*.

10 Application and Implementation

注

Information in the following applications sections is not part of the TI component specification, and TI does not warrant its accuracy or completeness. TI's customers are responsible for determining suitability of components for their purposes. Customers should validate and test their design implementation to confirm system functionality.

10.1 Application Information

The TMUX11xx family offers ultra-low input/output leakage currents and low charge injection. These devices operate up to 5.5 V, and offer true rail-to-rail input and output switching of both analog and digital signals. The TMUX113x devices have low on-capacitance which allows faster settling time when switching between inputs in the time domain. These features make the TMUX11xx devices a family of precision, high-performance switches and multiplexers for low-voltage applications.

10.2 Typical Application

图 30 shows an example circuit where the TMUX1133 or TMUX1134 can be used to minimize board space by integrating various applications into a multi-channel 2:1 (SPDT) switch. The application uses a 3-channel, or 4-channel SPDT switch in order to optimize the tradeoffs of system flexibility and board space.



图 30. Multi-channel 2:1, Switching Applications

10.3 Design Requirements

For this design example, use the parameters listed in 表 3.

表 3. Design Parameters

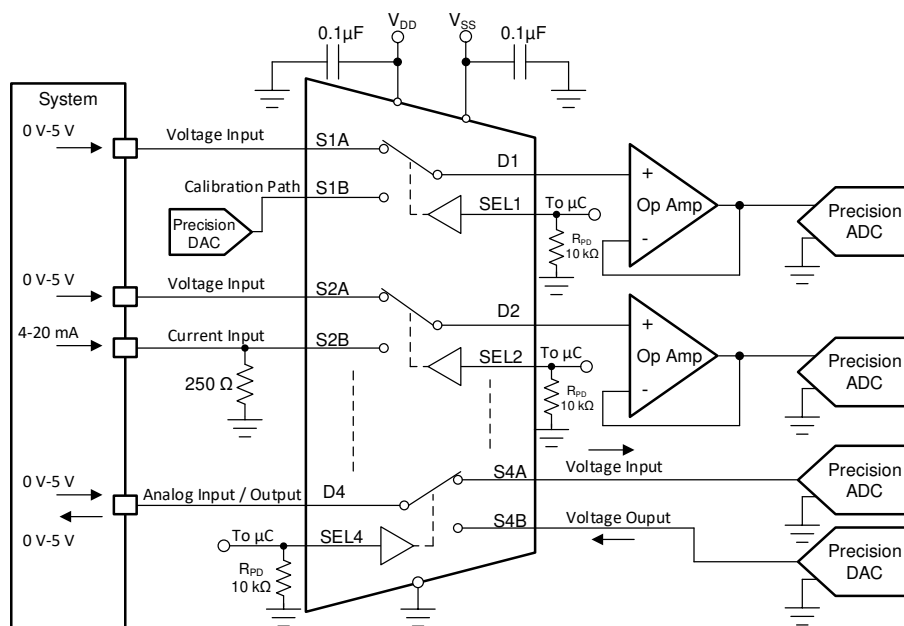
PARAMETERS	VALUES
Supply (V_{DD})	5 V
Input / Output Voltage range	0 V to 5V
Input / Output Current range	4 mA to 20 mA
Control logic thresholds	1.8 V compatible

10.4 Detailed Design Procedure

The TMUX113x devices can be operated without any external components except for the supply decoupling capacitors, however pull-down or pull-up resistors are recommended on the logic control inputs to ensure each channel is in a known state. All inputs passing through the switch must fall within the recommended operating conditions, including signal range and continuous current. For this design with a single supply of 5 V the signal range can be 0 V to 5 V, and the max continuous current can be 30 mA.

Industrial applications such as in Factory Automation & Control and Test & Measurement benefit from using a multi-channel 2:1 switch because it allows additional flexibility in the design. A single 2:1 switch has numerous applications such as:

1. Switching between an analog signal path and a calibration path in order to ensure the system is calibrated across the life of a product or after installation.
2. Configuring a single channel to accept either a voltage or current input through software - allowing for system flexibility across applications where the end users input signals may differ.
3. Allowing a single channel to be configured as either an analog input or analog output. Providing additional control to a system while minimizing the number of physical connectors

图 30 shows how to configure a multi-channel analog switch to address these design implementations for additional control and flexibility in the system. The on-resistance of the TMUX113x devices is very low, 2Ω typical, and has a max on-leakage current of 2nA which allows the devices to be used in precision measurement applications. A system with a 4mA to 20mA signal can achieve >20bits of precision due to the extremely low leakage current of the TMUX113x devices.

10.5 Application Curve

The TMUX113x devices are capable of switching signals with minimal distortion because of the ultra-low leakage currents and low on-resistance. 图 31 shows how the leakage current of the TMUX113x varies with different input voltages.



图 31. On-Leakage vs Source or Drain Voltage

11 Power Supply Recommendations

The TMUX113x devices operate across a wide supply range of 1.08 V to 5.5 V single supply, or ± 2.75 V for dual supply applications. For single supply voltage applications V_{SS} must be connected to GND. Do not exceed the absolute maximum ratings because stresses beyond the listed ratings can cause permanent damage to the devices.

Power-supply bypassing improves noise margin and prevents switching noise propagation from the V_{DD} and V_{SS} supplies to other components. Good power-supply decoupling is important to achieve optimum performance. For improved supply noise immunity, use a supply decoupling capacitor ranging from 0.1 μF to 10 μF from V_{DD} and V_{SS} to ground. Place the bypass capacitors as close to the power supply pins of the device as possible using low-impedance connections. TI recommends using multi-layer ceramic chip capacitors (MLCCs) that offer low equivalent series resistance (ESR) and inductance (ESL) characteristics for power-supply decoupling purposes. For very sensitive systems, or for systems in harsh noise environments, avoiding the use of vias for connecting the capacitors to the device pins may offer superior noise immunity. The use of multiple vias in parallel lowers the overall inductance and is beneficial for connections to ground planes.

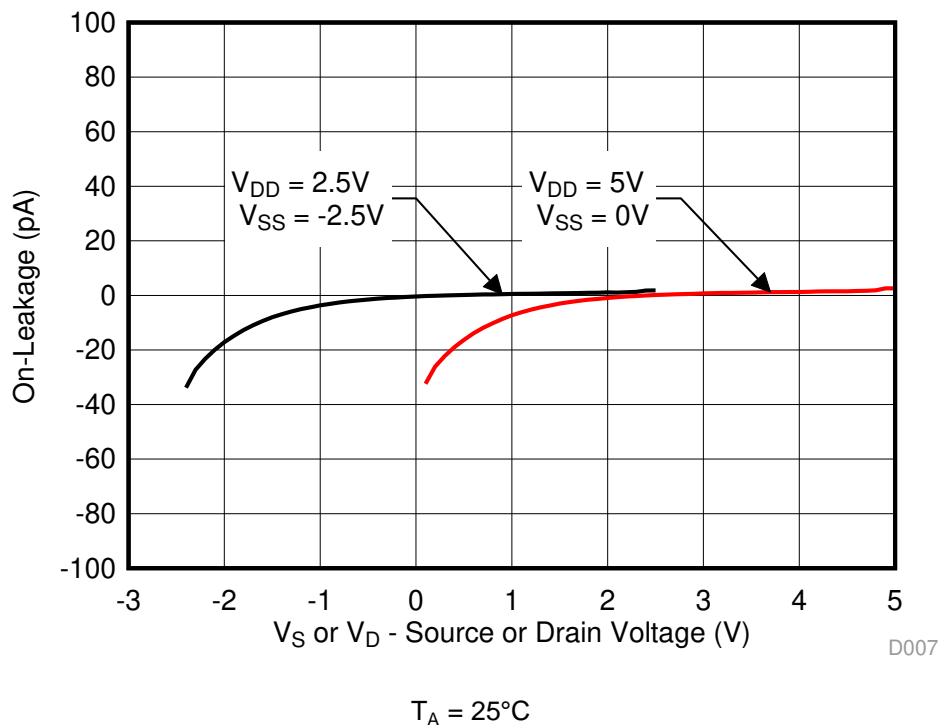
12 Layout

12.1 Layout Guidelines

12.1.1 Layout Information

When a PCB trace turns a corner at a 90° angle, a reflection can occur. A reflection occurs primarily because of the change of width of the trace. At the apex of the turn, the trace width increases to 1.414 times the width. This increase upsets the transmission-line characteristics, especially the distributed capacitance and self-inductance of the trace which results in the reflection. Not all PCB traces can be straight and therefore some traces must turn corners. [图 32](#) shows progressively better techniques of rounding corners. Only the last example (BEST) maintains constant trace width and minimizes reflections.



图 32. Trace Example

Route high-speed signals using a minimum of vias and corners which reduces signal reflections and impedance changes. When a via must be used, increase the clearance size around it to minimize its capacitance. Each via introduces discontinuities in the signal's transmission line and increases the chance of picking up interference from the other layers of the board. Be careful when designing test points, through-hole pins are not recommended at high frequencies.

[图 33](#) and [图 34](#) illustrate examples of a PCB layout with the TMUX1133 and TMUX1134 respectively. Some key considerations are:

- Decouple the V_{DD} and V_{SS} pins with a 0.1- μF capacitor, placed as close to the pin as possible. Make sure that the capacitor voltage rating is sufficient for the supply voltage.
- Keep the input lines as short as possible.
- Use a solid ground plane to help reduce electromagnetic interference (EMI) noise pickup.
- Do not run sensitive analog traces in parallel with digital traces. Avoid crossing digital and analog traces if possible, and only make perpendicular crossings when necessary.

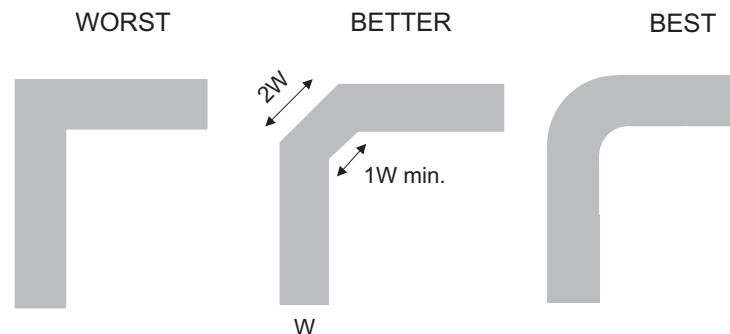
12.2 Layout Example

图 33 shows an example board layout for the TMUX1133.



图 33. TMUX1133 Layout Example

图 34 shows an example board layout for the TMUX1134.

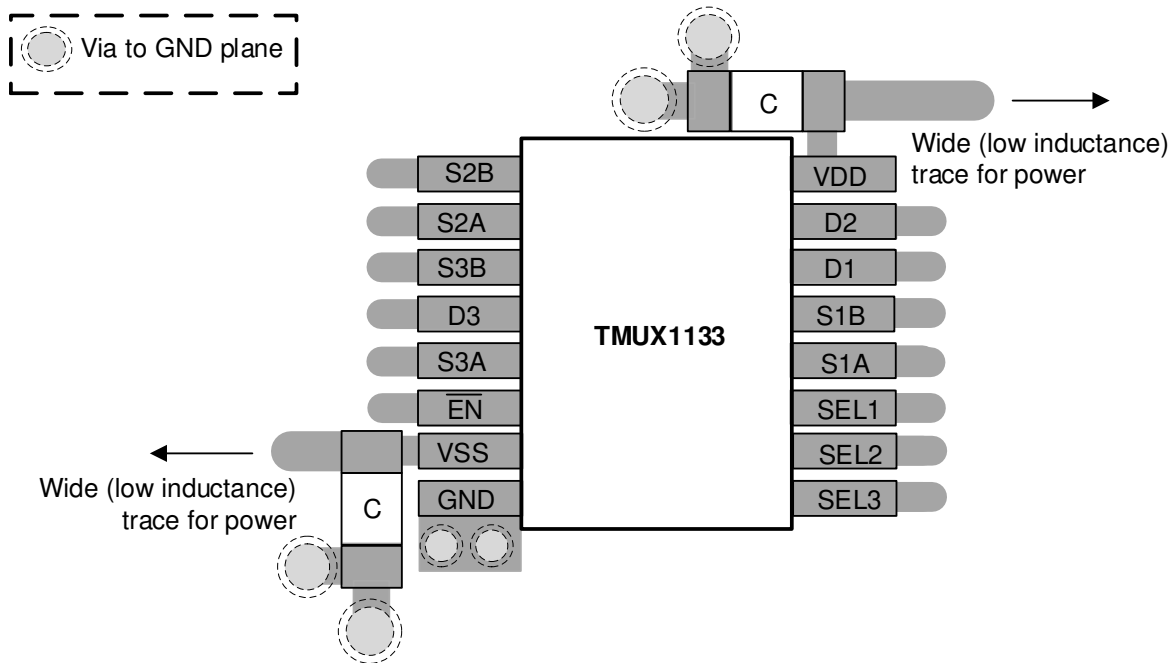

图 34. TMUX1134 Layout Example

13 器件和文档支持

13.1 文档支持

13.1.1 相关文档

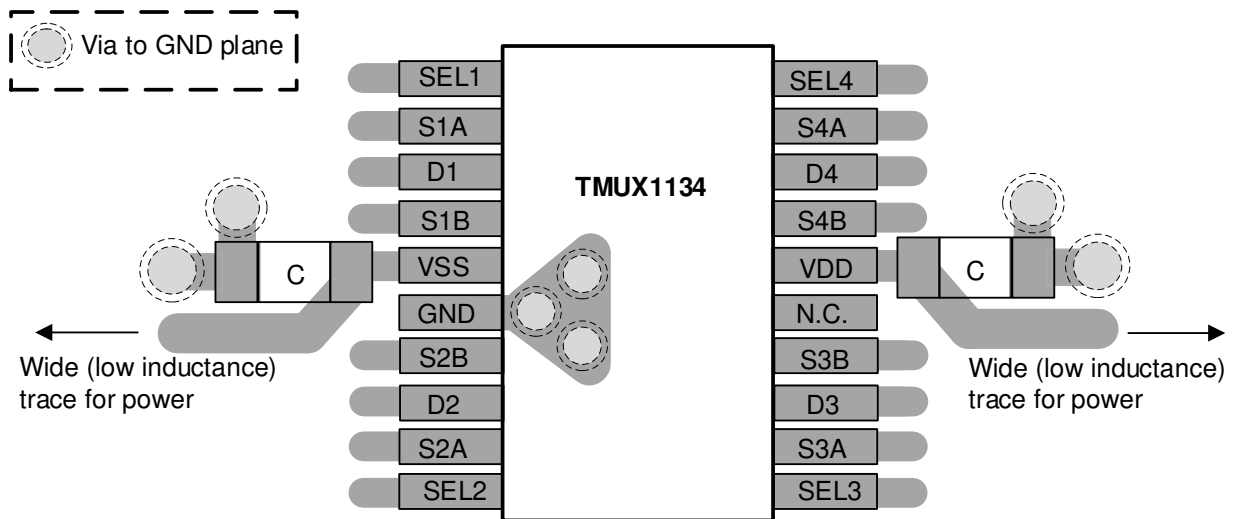
德州仪器 (TI), 《采用 [MSP430™](#) 的超声波燃气表前端参考设计》。

德州仪器 (TI), 《[真差分 4 x 2 多路复用器、模拟前端、同步采样 ADC 电路](#)》。

德州仪器 (TI), 《[使用低 CON 多路复用器改善稳定性问题](#)》。

德州仪器 (TI), 《[使用 1.8V 逻辑多路复用器和开关简化设计](#)》。

德州仪器 (TI), 《[利用关断保护信号开关消除电源排序](#)》。

德州仪器 (TI), 《[高电压模拟多路复用器的系统级保护](#)》。

德州仪器 (TI), 《[QFN/SON PCB 连接](#)》。

德州仪器 (TI), 《[四方扁平封装无引线逻辑封装](#)》。

13.2 相关链接

下表列出了快速访问链接。类别包括技术文档、支持和社区资源、工具和软件，以及立即订购快速访问。

表 4. 相关链接

器件	产品文件夹	立即订购	技术文档	工具与软件	支持和社区
TMUX1133	单击此处	单击此处	单击此处	单击此处	单击此处
TMUX1134	单击此处	单击此处	单击此处	单击此处	单击此处

13.3 接收文档更新通知

要接收文档更新通知，请导航至 TI.com.cn 上的器件产品文件夹。单击右上角的 [通知我](#) 进行注册，即可每周接收产品信息更改摘要。有关更改的详细信息，请查看任何已修订文档中包含的修订历史记录。

13.4 社区资源

[TI E2E™ support forums](#) are an engineer's go-to source for fast, verified answers and design help — straight from the experts. Search existing answers or ask your own question to get the quick design help you need.

Linked content is provided "AS IS" by the respective contributors. They do not constitute TI specifications and do not necessarily reflect TI's views; see TI's [Terms of Use](#).

13.5 商标

E2E is a trademark of Texas Instruments.

13.6 静电放电警告



ESD 可能会损坏该集成电路。德州仪器 (TI) 建议通过适当的预防措施处理所有集成电路。如果不遵守正确的处理措施和安装程序，可能会损坏集成电路。

ESD 的损坏小至导致微小的性能降级，大至整个器件故障。精密的集成电路可能更容易受到损坏，这是因为非常细微的参数更改都可能会导致器件与其发布的规格不相符。

13.7 Glossary

[SLYZ022](#) — *TI Glossary*.

This glossary lists and explains terms, acronyms, and definitions.

14 机械、封装和可订购信息

以下页面包含机械、封装和可订购信息。这些信息是指定器件的最新可用数据。数据如有变更，恕不另行通知，且不会对此文档进行修订。如需获取此数据表的浏览器版本，请查阅左侧的导航栏。

PACKAGING INFORMATION

Orderable Device	Status (1)	Package Type	Package Drawing	Pins	Package Qty	Eco Plan (2)	Lead finish/ Ball material (6)	MSL Peak Temp (3)	Op Temp (°C)	Device Marking (4/5)	Samples
TMUX1133PWR	ACTIVE	TSSOP	PW	16	2000	RoHS & Green	NIPDAU	Level-1-260C-UNLIM	-40 to 125	TM1133	Samples
TMUX1134PWR	ACTIVE	TSSOP	PW	20	2000	RoHS & Green	NIPDAU	Level-1-260C-UNLIM	-40 to 125	TM1134	Samples

(1) The marketing status values are defined as follows:

ACTIVE: Product device recommended for new designs.

LIFEBUY: TI has announced that the device will be discontinued, and a lifetime-buy period is in effect.

NRND: Not recommended for new designs. Device is in production to support existing customers, but TI does not recommend using this part in a new design.

PREVIEW: Device has been announced but is not in production. Samples may or may not be available.

OBSOLETE: TI has discontinued the production of the device.

(2) **RoHS:** TI defines "RoHS" to mean semiconductor products that are compliant with the current EU RoHS requirements for all 10 RoHS substances, including the requirement that RoHS substance do not exceed 0.1% by weight in homogeneous materials. Where designed to be soldered at high temperatures, "RoHS" products are suitable for use in specified lead-free processes. TI may reference these types of products as "Pb-Free".

RoHS Exempt: TI defines "RoHS Exempt" to mean products that contain lead but are compliant with EU RoHS pursuant to a specific EU RoHS exemption.

Green: TI defines "Green" to mean the content of Chlorine (Cl) and Bromine (Br) based flame retardants meet JS709B low halogen requirements of <=1000ppm threshold. Antimony trioxide based flame retardants must also meet the <=1000ppm threshold requirement.

(3) MSL, Peak Temp. - The Moisture Sensitivity Level rating according to the JEDEC industry standard classifications, and peak solder temperature.

(4) There may be additional marking, which relates to the logo, the lot trace code information, or the environmental category on the device.

(5) Multiple Device Markings will be inside parentheses. Only one Device Marking contained in parentheses and separated by a "~" will appear on a device. If a line is indented then it is a continuation of the previous line and the two combined represent the entire Device Marking for that device.

(6) Lead finish/Ball material - Orderable Devices may have multiple material finish options. Finish options are separated by a vertical ruled line. Lead finish/Ball material values may wrap to two lines if the finish value exceeds the maximum column width.

Important Information and Disclaimer:The information provided on this page represents TI's knowledge and belief as of the date that it is provided. TI bases its knowledge and belief on information provided by third parties, and makes no representation or warranty as to the accuracy of such information. Efforts are underway to better integrate information from third parties. TI has taken and continues to take reasonable steps to provide representative and accurate information but may not have conducted destructive testing or chemical analysis on incoming materials and chemicals. TI and TI suppliers consider certain information to be proprietary, and thus CAS numbers and other limited information may not be available for release.

In no event shall TI's liability arising out of such information exceed the total purchase price of the TI part(s) at issue in this document sold by TI to Customer on an annual basis.

TAPE AND REEL INFORMATION

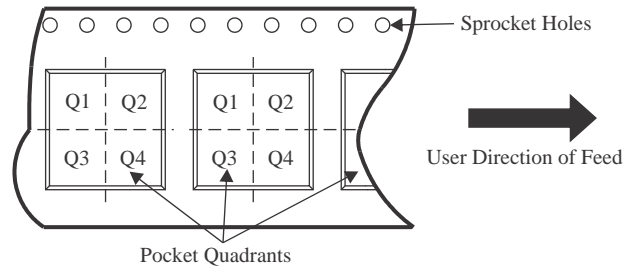
QUADRANT ASSIGNMENTS FOR PIN 1 ORIENTATION IN TAPE

*All dimensions are nominal

Device	Package Type	Package Drawing	Pins	SPQ	Reel Diameter (mm)	Reel Width W1 (mm)	A0 (mm)	B0 (mm)	K0 (mm)	P1 (mm)	W (mm)	Pin1 Quadrant
TMUX1133PWR	TSSOP	PW	16	2000	330.0	12.4	6.9	5.6	1.6	8.0	12.0	Q1
TMUX1134PWR	TSSOP	PW	20	2000	330.0	16.4	6.95	7.0	1.4	8.0	16.0	Q1

TAPE AND REEL BOX DIMENSIONS

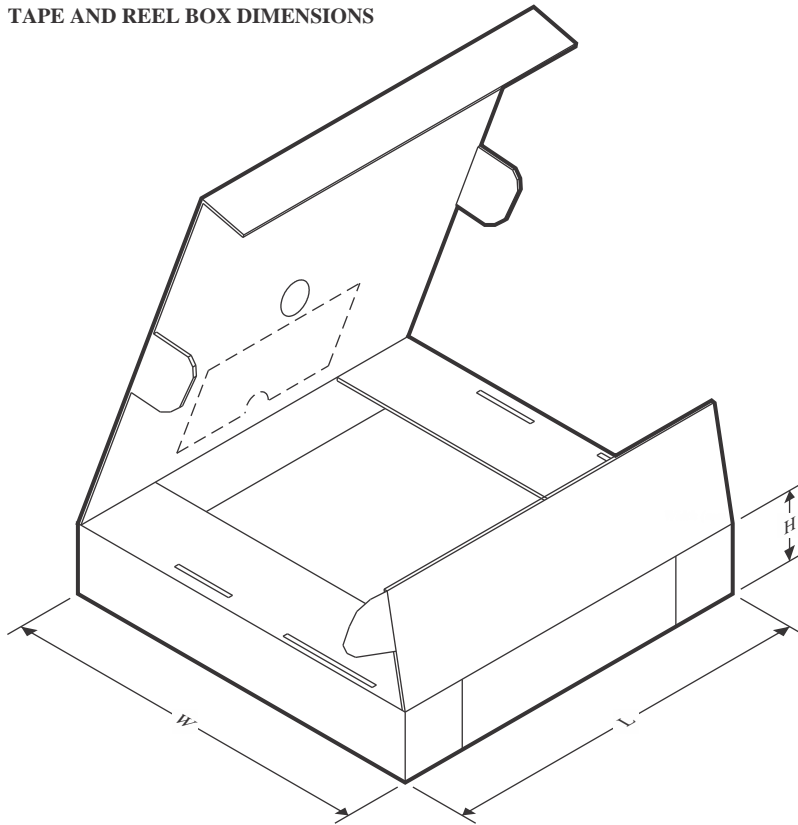

*All dimensions are nominal

Device	Package Type	Package Drawing	Pins	SPQ	Length (mm)	Width (mm)	Height (mm)
TMUX1133PWR	TSSOP	PW	16	2000	356.0	356.0	35.0
TMUX1134PWR	TSSOP	PW	20	2000	356.0	356.0	35.0



4220206/A 02/2017

NOTES:

1. All linear dimensions are in millimeters. Any dimensions in parenthesis are for reference only. Dimensioning and tolerancing per ASME Y14.5M.
2. This drawing is subject to change without notice.
3. This dimension does not include mold flash, protrusions, or gate burrs. Mold flash, protrusions, or gate burrs shall not exceed 0.15 mm per side.
4. This dimension does not include interlead flash. Interlead flash shall not exceed 0.25 mm per side.
5. Reference JEDEC registration MO-153.

EXAMPLE BOARD LAYOUT

PW0020A

TSSOP - 1.2 mm max height

SMALL OUTLINE PACKAGE



LAND PATTERN EXAMPLE
EXPOSED METAL SHOWN
SCALE: 10X



SOLDER MASK DETAILS

4220206/A 02/2017

NOTES: (continued)

- 6. Publication IPC-7351 may have alternate designs.
- 7. Solder mask tolerances between and around signal pads can vary based on board fabrication site.

EXAMPLE STENCIL DESIGN

PW0020A

TSSOP - 1.2 mm max height

SMALL OUTLINE PACKAGE



SOLDER PASTE EXAMPLE
BASED ON 0.125 mm THICK STENCIL
SCALE: 10X

4220206/A 02/2017

NOTES: (continued)

8. Laser cutting apertures with trapezoidal walls and rounded corners may offer better paste release. IPC-7525 may have alternate design recommendations.
9. Board assembly site may have different recommendations for stencil design.

PW (R-PDSO-G20)

PLASTIC SMALL OUTLINE



- NOTES:
- A. All linear dimensions are in millimeters.
 - B. This drawing is subject to change without notice.
 - C. Publication IPC-7351 is recommended for alternate design.
 - D. Laser cutting apertures with trapezoidal walls and also rounding corners will offer better paste release. Customers should contact their board assembly site for stencil design recommendations. Refer to IPC-7525 for other stencil recommendations.
 - E. Customers should contact their board fabrication site for solder mask tolerances between and around signal pads.



4220204/A 02/2017

NOTES:

1. All linear dimensions are in millimeters. Any dimensions in parenthesis are for reference only. Dimensioning and tolerancing per ASME Y14.5M.
2. This drawing is subject to change without notice.
3. This dimension does not include mold flash, protrusions, or gate burrs. Mold flash, protrusions, or gate burrs shall not exceed 0.15 mm per side.
4. This dimension does not include interlead flash. Interlead flash shall not exceed 0.25 mm per side.
5. Reference JEDEC registration MO-153.

EXAMPLE BOARD LAYOUT

PW0016A

TSSOP - 1.2 mm max height

SMALL OUTLINE PACKAGE



LAND PATTERN EXAMPLE
EXPOSED METAL SHOWN
SCALE: 10X



4220204/A 02/2017

NOTES: (continued)

- 6. Publication IPC-7351 may have alternate designs.
- 7. Solder mask tolerances between and around signal pads can vary based on board fabrication site.

EXAMPLE STENCIL DESIGN

PW0016A

TSSOP - 1.2 mm max height

SMALL OUTLINE PACKAGE



SOLDER PASTE EXAMPLE
BASED ON 0.125 mm THICK STENCIL
SCALE: 10X

4220204/A 02/2017

NOTES: (continued)

8. Laser cutting apertures with trapezoidal walls and rounded corners may offer better paste release. IPC-7525 may have alternate design recommendations.
9. Board assembly site may have different recommendations for stencil design.

重要声明和免责声明

TI“按原样”提供技术和可靠性数据（包括数据表）、设计资源（包括参考设计）、应用或其他设计建议、网络工具、安全信息和其他资源，不保证没有瑕疵且不做任何明示或暗示的担保，包括但不限于对适销性、某特定用途方面的适用性或不侵犯任何第三方知识产权的暗示担保。

这些资源可供使用 TI 产品进行设计的熟练开发人员使用。您将自行承担以下全部责任：(1) 针对您的应用选择合适的 TI 产品，(2) 设计、验证并测试您的应用，(3) 确保您的应用满足相应标准以及任何其他功能安全、信息安全、监管或其他要求。

这些资源如有变更，恕不另行通知。TI 授权您仅可将这些资源用于研发本资源所述的 TI 产品的应用。严禁对这些资源进行其他复制或展示。您无权使用任何其他 TI 知识产权或任何第三方知识产权。您应全额赔偿因在这些资源的使用中对 TI 及其代表造成的任何索赔、损害、成本、损失和债务，TI 对此概不负责。

TI 提供的产品受 [TI 的销售条款](#) 或 [ti.com](#) 上其他适用条款/TI 产品随附的其他适用条款的约束。TI 提供这些资源并不会扩展或以其他方式更改 TI 针对 TI 产品发布的适用的担保或担保免责声明。

TI 反对并拒绝您可能提出的任何其他或不同的条款。

邮寄地址：Texas Instruments, Post Office Box 655303, Dallas, Texas 75265

Copyright © 2022，德州仪器 (TI) 公司

X-ON Electronics

Largest Supplier of Electrical and Electronic Components

Click to view similar products for [Analogue Switch ICs](#) category:

Click to view products by [Texas Instruments](#) manufacturer:

Other Similar products are found below :

[FSA3051TMX](#) [NLAS5223BLMNR2G](#) [NLX2G66DMUTCG](#) [TC74HC4066AFTEL](#) [425541DB](#) [DG403DY](#) [099044FB](#) [MAX4762ETB+](#)
[NLAS3799BMNR2G](#) [NLAS5123MNR2G](#) [ISL84684IR](#) [PI5A4157CEX](#) [PI5A4599BCEX](#) [NLAS4717EPFCT1G](#) [PI5A3167CCEX](#)
[SLAS3158MNR2G](#) [PI5A392AQE](#) [ADG714BCPZ-REEL7](#) [DG333ALDW-T1-E3](#) [ISL43113IB](#) [ISL43140IB](#) [ISL43140IBZ-T](#) [ISL43143IR](#)
[ISL43L120IR](#) [ISL43L121IR](#) [ISL43L122IR](#) [ISL43L220IR](#) [ISL43L410IR](#) [ISL43L420IR](#) [ISL43L710IR](#) [ISL43L711IR](#) [ISL43L712IR](#)
[ISL84053IA](#) [ISL84514IB](#) [ISL84516IB](#) [ISL84684IUZ-T](#) [LNLASB3157DFT2G](#) [NLAS324US](#) [NLASTV4599DFT2G](#) [TPW4053-SR](#)
[WAS4642Q-24/TR](#) [ADG842YKSZ-REEL7](#) [WAS4766C-9/TR](#) [WAS7227Q-10/TR](#) [WAS4646C-36/TR](#) [WAS4735Q-16/TR](#) [BL1532TQFN](#)
[RS2233YS16](#) [CH483M](#) [TMUX1248DCKR](#)