

# 具有可调节输出功率限制功能的 TPS1663x 60V、6A 电子保险丝

## 1 特性

- 工作电压范围为 4.5V 至 60V，绝对最大电压为 67V
- 集成 60V、31mΩ R<sub>ON</sub> 热插拔 FET
- 可调电流限制为 0.6A 至 6A (± 7%)
- 低静态电流，关断时为 21μA
- 可调节输出功率限制（仅限 TPS16632）(± 6%)
- 精度为 ± 2% 的可调节 UVLO 和 OVP 切断
  - 39V 固定最大过压钳位（仅限 TPS16632）
- 可调节输出压摆率控制，用于实现浪涌电流限制
  - 通过在器件加电期间进行热调节，为大型及未知电容负载充电
- 电源正常输出 (PGOOD)
- 可选过流故障响应选项（自动重试和闭锁模式）
- 模拟电流监控器 (IMON) 输出 (± 6%)
- 通过 UL 2367 认证
  - 文件编号 E169910
  - RILIM ≥ 3kΩ
- 通过 IEC 62368-1 认证
- 采用易于使用的 24 引脚 VQFN 封装

## 2 应用

- 工厂自动化和控制 – PLC、DCS、HMI、I/O 模块、传感器集线器
- 电机驱动器 – CNC、编码器电源
- 电子断路器
- 电信无线电
- 工业打印机

## 3 说明

TPS1663x 是一款易于使用的正极 60V、6A 电子保险丝，具有一个 31mΩ 的集成 FET。提供对负载、电源和电子保险丝本身的保护以及可调节特性如精确过流保护、快速短路保护、输出压摆率控制、过压保护和欠压锁定。TPS16632 器件集成了可调节输出功率限制 (PLIM) 功能，可简化并实现对诸如 IEC61010-1 和 UL1310 等标准的遵从。该器件还具有可调节过流保护功能。可以使用 PGOOD 来启用和禁用下游直流/直流转换器控制。

借助关断引脚，可以从外部控制内部 FET 的启用和禁用以及将器件置于低电流关断模式。为实现系统状态监视和下游负载控制，该器件提供了故障和精确的电流监视器输出。MODE 引脚可用于在两种限流故障响应（闭锁自动重试）之间灵活地对器件进行配置。

这些器件采用 4mm × 4mm 24 引脚 VQFN 封装，额定温度范围为 -40°C 至 +125°C。

### 器件信息(1)

器件型号	封装	封装尺寸 (标称值)
TPS16630 TPS16632	VQFN (24)	4.00mm × 4.00mm
TPS16630	HTSSOP (20)	6.50mm × 4.40mm

(1) 如需了解所有可用封装，请参阅数据表末尾的可订购产品附录。

简化原理图

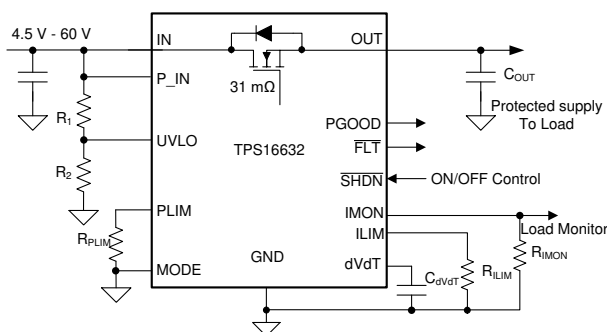

TPS16632 的输出功率限制性能

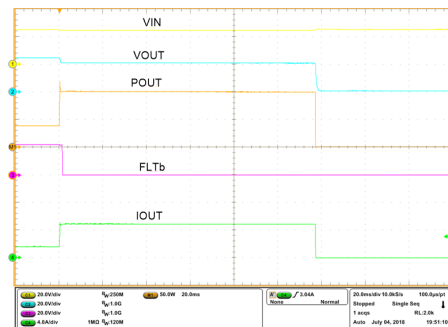

## 目录

1	特性 .....	1	9.4	Device Functional Modes .....	24
2	应用 .....	1	<b>10</b>	<b>Application and Implementation</b> .....	<b>25</b>
3	说明 .....	1	10.1	Application Information .....	25
4	修订历史记录 .....	2	10.2	Typical Application .....	25
5	<b>Device Comparison Table</b> .....	<b>4</b>	10.3	System Examples .....	28
6	<b>Pin Configuration and Functions</b> .....	<b>4</b>	<b>11</b>	<b>Power Supply Recommendations</b> .....	<b>28</b>
7	<b>Specifications</b> .....	<b>6</b>	11.1	Transient Protection .....	28
7.1	Absolute Maximum Ratings .....	6	<b>12</b>	<b>Layout</b> .....	<b>30</b>
7.2	ESD Ratings .....	6	12.1	Layout Guidelines .....	30
7.3	Recommended Operating Conditions .....	6	12.2	Layout Example .....	31
7.4	Thermal Information .....	6	<b>13</b>	<b>器件和文档支持</b> .....	<b>33</b>
7.5	Electrical Characteristics .....	7	13.1	文档支持 .....	33
7.6	Timing Requirements .....	8	13.2	接收文档更新通知 .....	33
7.7	Typical Characteristics .....	9	13.3	社区资源 .....	33
<b>8</b>	<b>Parameter Measurement Information</b> .....	<b>12</b>	13.4	商标 .....	33
<b>9</b>	<b>Detailed Description</b> .....	<b>13</b>	13.5	静电放电警告 .....	33
9.1	Overview .....	13	13.6	Glossary .....	33
9.2	Functional Block Diagram .....	14	<b>14</b>	<b>机械、封装和可订购信息</b> .....	<b>33</b>
9.3	Feature Description .....	15	14.1	Package Option Addendum .....	34

## 4 修订历史记录

Changes from Revision D (August 2019) to Revision E	Page
• 将“UL 2367 和 UL 60950 认证正在处理中”更改为“通过 UL 2367 认证” .....	1
• 向 <a href="#">特性</a> 部分添加了“通过 IEC 62368-1 认证” .....	1

Changes from Revision C (March 2019) to Revision D	Page
• 更改了 <a href="#">特性</a> 中的绝对最大电压 .....	1
• 更改了 <a href="#">特性</a> 中的可调节输出功率限制 .....	1
• Changed the <a href="#">Absolute Maximum Ratings</a> IN, P_IN, OUT, UVLO, $\overline{\text{FLT}}$ , PGOOD maximum input voltage .....	6
• Added $T_A = 25^\circ\text{C}$ to the <a href="#">Absolute Maximum Ratings</a> IN, P_IN (10ms transient) input voltage .....	6
• Changed the $V_{(\text{OVPF})}$ maximum in <a href="#">Electrical Characteristics</a> .....	7
• Changed $V_{(\text{SEL\_PLIM})}$ , $I_{(\text{PLIM})}$ , and $I_{(\text{dVdT})}$ minimum and maximum .....	7
• Changed the $P_{(\text{PLIM})}$ minimum, typical, and maximum .....	7

Changes from Revision B (December 2018) to Revision C	Page
• 已更改 将“预告信息”更改为“生产数据” .....	1

Changes from Revision A (October 2018) to Revision B	Page
• Updated the TPS16632 RGE Package VQFN .....	4
• Updated <a href="#">Functional Block Diagram</a> .....	14
• Updated <a href="#">Layout Example</a> .....	31

---

**Changes from Original (September 2018) to Revision A****Page**

- 
- 已更改 更改了封装信息..... 1
-

## 5 Device Comparison Table

PART NUMBER	OVERVOLTAGE PROTECTION	ADJUSTABLE OUTPUT POWER LIMITING
TPS16630	Overvoltage cut-off, adjustable	No
TPS16632	Overvoltage clamp, fixed (39-V max)	Yes

## 6 Pin Configuration and Functions

TPS16630 RGE Package  
24-Pin VQFN  
Top View

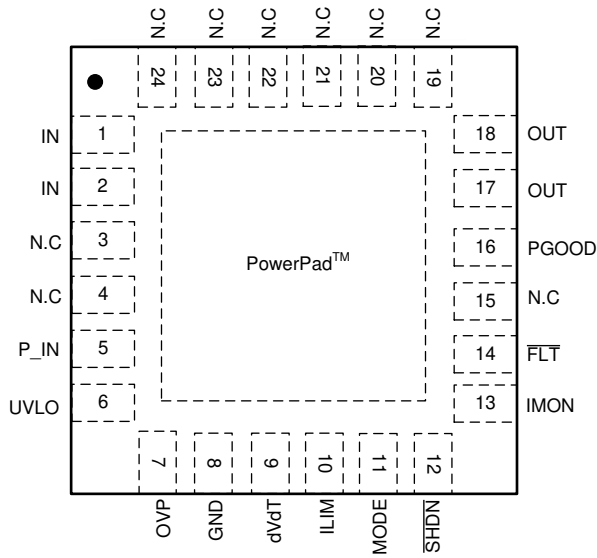

TPS16632 RGE Package  
24-Pin VQFN  
Top View

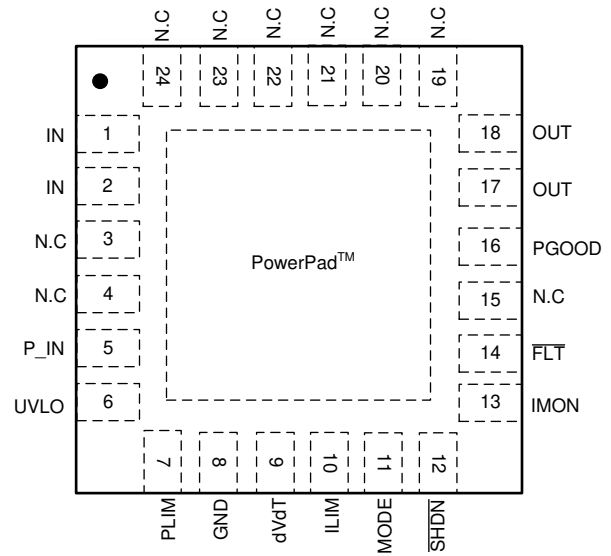

TPS16630 PWP Package  
20-Pin HTSSOP  
Top View

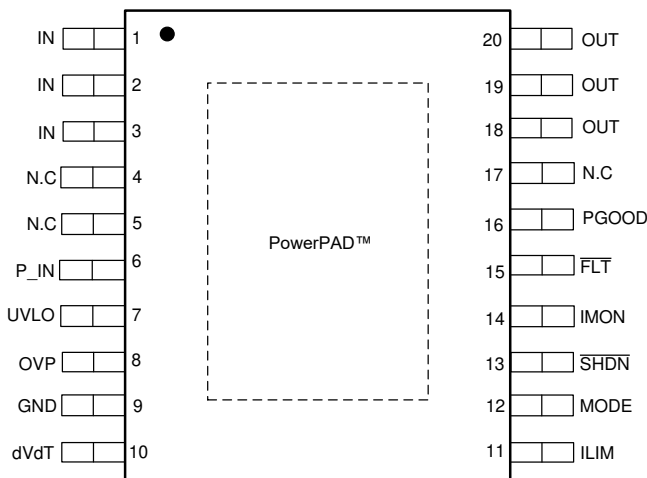

### Pin Functions

NAME	PIN			TYPE	DESCRIPTION
	TPS16630		TPS16632		
	VQFN	HTSSOP	VQFN		
IN	1	1	1	P	Power Input. Connects to the DRAIN of the internal FET
	2	2	2		
	—	3	—		
P_IN	5	6	5	P	Supply voltage of the device. Always connect P_IN to IN directly
UVLO	6	7	6	I	Input for setting the programmable undervoltage lockout threshold. An undervoltage event turns off the internal FET and asserts $\overline{\text{FLT}}$ to indicate the power-failure.
OVP	7	8	—	I	Input for setting the adjustable overvoltage protection threshold (For TPS16630 Only). An overvoltage event turns off the internal FET and asserts $\overline{\text{FLT}}$ to indicate the overvoltage fault.
PLIM	—	—	7	I	Input for setting the adjustable output power limiting threshold (TPS16632 Only). Connect a resistor across PLIM to GND to set the output power limit. Connect PLIM to GND if PLIM feature is not used. See <a href="#">Output Power Limiting, PLIM (TPS16632 Only)</a> section.
GND	8	9	8	—	Connect GND to system ground
dVdT	9	10	9	I/O	A capacitor from this pin to GND sets output voltage slew rate. Leaving this pin floating enables device power up in thermal regulation resulting in fast output charge. See the <a href="#">Hot Plug-In and In-Rush Current Control</a> section
ILIM	10	11	10	I/O	A resistor from this pin to GND sets the overload limit. See <a href="#">Overload and Short Circuit Protection</a> section.
MODE	11	12	11	I	Mode selection pin for Overload fault response. See the <a href="#">Device Functional Modes</a> section
$\overline{\text{SHDN}}$	12	13	12	I	Shutdown pin. Pulling $\overline{\text{SHDN}}$ low makes the device to enter into low power shutdown mode. Cycling $\overline{\text{SHDN}}$ pin voltage resets the device that has latched off due to a fault condition
IMON	13	14	13	O	Analog current monitor output. This pin sources a scaled down ratio of current through the internal FET. A resistor from this pin to GND converts current to proportional voltage. If unused, leave it floating
$\overline{\text{FLT}}$	14	15	14	O	Fault event indicator. It is an open drain output. If unused, leave floating or connect to GND
PGOOD	16	16	16	O	Active High. A high indicates that the internal FET is enhanced. PGOOD goes low when the internal FET is turned OFF during a fault or when $\overline{\text{SHDN}}$ is pulled low. If PGOOD is unused then connect to GND or leave it floating
OUT	17	18	17	P	Power Output of the device.
	18	19	18		
	—	20	—		
N.C	3	4	3	—	No Connect
	4	5	4		
	15	17	15		
	19	—	19		
	20	—	20		
	21	—	21		
	22	—	22		
	23	—	23		
24	—	24			
PowerPad™				—	Connect PowerPad to GND plane for heat sinking. Do not use PowerPad as the only electrical connection to GND

## 7 Specifications

### 7.1 Absolute Maximum Ratings

over operating free-air temperature range (unless otherwise noted)<sup>(1)</sup>

		MIN	MAX	UNIT
IN, P_IN, OUT, UVLO, $\overline{\text{FLT}}$ , PGOOD	Input Voltage	-0.3	67	V
IN, P_IN (10ms transient), $T_A = 25^\circ\text{C}$		-0.3	75	
OVP, dVdT, IMON, MODE, $\overline{\text{SHDN}}$ , ILIM		-0.3	5.5	
$\overline{\text{I}}_{\text{FLT}}$ , $\text{I}_{\text{dVdT}}$ , $\text{I}_{\text{PGOOD}}$	Sink current		10	mA
$\text{I}_{\text{dVdT}}$ , $\text{I}_{\text{ILIM}}$ , $\text{I}_{\text{PLIM}}$ , $\text{I}_{\text{MODE}}$ , $\overline{\text{I}}_{\text{SHDN}}$	Source current	Internally limited		
$T_J$	Operating Junction temperature	-40	150	°C
	Transient junction temperature	-65	$T_{(\text{TSD})}$	
$T_{\text{stg}}$	Storage temperature	-65	150	

- (1) Stresses beyond those listed under *Absolute Maximum Rating* may cause permanent damage to the device. These are stress ratings only, which do not imply functional operation of the device at these or any other conditions beyond those indicated under *Recommended Operating Condition*. Exposure to absolute-maximum-rated conditions for extended periods may affect device reliability.

### 7.2 ESD Ratings

			VALUE	UNIT
$V_{(\text{ESD})}$	Electrostatic discharge	Human body model (HBM), per ANSI/ESDA/JEDEC JS-001, all pins <sup>(1)</sup>	±2000	V
		Charged device model (CDM), per JEDEC specification JESD22-C101, all pins <sup>(2)</sup>	±1000	

- (1) JEDEC document JEP155 states that 500-V HBM allows safe manufacturing with a standard ESD control process.  
 (2) JEDEC document JEP157 states that 250-V CDM allows safe manufacturing with a standard ESD control process.

### 7.3 Recommended Operating Conditions

over operating free-air temperature range (unless otherwise noted)

		MIN	NOM	MAX	UNIT
IN, P_IN	Input Voltage	4.5		60	V
OUT, UVLO, PGOOD, $\overline{\text{FLT}}$		0		60	
OVP, dVdT, IMON, MODE		0		4	
$\overline{\text{SHDN}}$		0		5	
ILIM	Resistance	3		30	kΩ
PLIM		60.4		150	
IMON		1			
IN, P_IN, OUT	External Capacitance	0.1			μF
dVdT		10			nF
$T_J$	Operating Junction temperature	-40	25	125	°C

### 7.4 Thermal Information

THERMAL METRIC <sup>(1)</sup>		TPS1663		UNIT
		RGE (VSON)	PWP (HTSSOP)	
		24 PINS	20 PINS	
$R_{\theta\text{JA}}$	Junction-to-ambient thermal resistance	31.4	32.2	°C/W
$R_{\theta\text{JC(top)}}$	Junction-to-case (top) thermal resistance	23.2	23.4	°C/W
$R_{\theta\text{JB}}$	Junction-to-board thermal resistance	10.2	10	°C/W
$\Psi_{\text{JT}}$	Junction-to-top characterization parameter	0.3	0.3	°C/W
$\Psi_{\text{JB}}$	Junction-to-board characterization parameter	10.2	9.9	°C/W

- (1) For more information about traditional and new thermal metrics, see the [Semiconductor and IC Package Thermal Metrics](#) application report.

**Thermal Information (continued)**

THERMAL METRIC <sup>(1)</sup>		TPS1663		UNIT
		RGE (VSON)	PWP (HTSSOP)	
		24 PINS	20 PINS	
R <sub>θJC(bot)</sub>	Junction-to-case (bottom) thermal resistance	2.8	3.6	°C/W

**7.5 Electrical Characteristics**

–40°C ≤ T<sub>A</sub> = T<sub>J</sub> ≤ +125°C, 4.5 V < V<sub>(IN)</sub> = V<sub>(P\_IN)</sub> < 60 V, V<sub>(SHDN)</sub> = 2 V, R<sub>(ILIM)</sub> = 30 kΩ, IMON = PGOOD = FLT = OPEN, C<sub>(OUT)</sub> = 1 μF, C<sub>(dVdT)</sub> = OPEN. (All voltages referenced to GND, (unless otherwise noted))

PARAMETER	TEST CONDITIONS	MIN	TYP	MAX	UNIT		
<b>SUPPLY VOLTAGE</b>							
V <sub>(IN)</sub> , V <sub>(P_IN)</sub>	Operating input voltage	4.5		60	V		
I <sub>Q(ON)</sub>	Supply current	Enabled: V <sub>(SHDN)</sub> = 2 V		1.38	1.7	mA	
I <sub>Q(OFF)</sub>		V <sub>(SHDN)</sub> = 0 V		21	60	μA	
V <sub>(OVC)</sub>	Over voltage clamp	TPS16632 Only, V <sub>(IN)</sub> > 40V, I <sub>(OUT)</sub> = 1mA		35.7	36.6	39	V
<b>UNDERVOLTAGE LOCKOUT (UVLO) INPUT</b>							
V <sub>(UVLOR)</sub>	UVLO threshold voltage, rising	1.176	1.2	1.224	V		
V <sub>(UVLOF)</sub>	UVLO threshold voltage, falling	1.09	1.122	1.15	V		
I <sub>(UVLO)</sub>	UVLO Input leakage current	0 V ≤ V <sub>(UVLO)</sub> ≤ 60 V		–150	8	150	nA
<b>OVERVOLTAGE PROTECTION (OVP) INPUT</b>							
V <sub>(OVPR)</sub>	over-voltage threshold voltage, rising	1.176	1.2	1.224	V		
V <sub>(OVPF)</sub>	over-voltage threshold voltage, falling	1.09	1.122	1.15	V		
I <sub>(OVP)</sub>	OVP Input leakage current	0 V ≤ V <sub>(OVP)</sub> ≤ 4 V		–150	0	150	nA
<b>CURRENT LIMIT PROGRAMMING (ILIM)</b>							
I <sub>(OL)</sub>	Over Load current limit	R <sub>(ILIM)</sub> = 30 kΩ, V <sub>(IN)</sub> – V <sub>(OUT)</sub> = 1 V		0.54	0.6	0.66	A
		R <sub>(ILIM)</sub> = 9 kΩ, V <sub>(IN)</sub> – V <sub>(OUT)</sub> = 1 V		1.84	2	2.16	A
		R <sub>(ILIM)</sub> = 4.02 kΩ, V <sub>(IN)</sub> – V <sub>(OUT)</sub> = 1 V		4.185	4.5	4.815	A
		R <sub>(ILIM)</sub> = 3 kΩ, V <sub>(IN)</sub> – V <sub>(OUT)</sub> = 1 V		5.58	6	6.42	A
I <sub>(FASTTRIP)</sub>	Fast-trip comparator threshold		2xI <sub>(OL)</sub>		A		
I <sub>(SCP)</sub>	Short Circuit Protect current		45		A		
<b>OUTPUT POWER LIMITING CONTROL (PLIM) INPUT – TPS16632 ONLY</b>							
V <sub>(SEL_PLIM)</sub>	Power Limit Feature select threshold	180	210	240	mV		
I <sub>(PLIM)</sub>	PLIM sourcing current	V <sub>(PLIM)</sub> = 0 V		4.4	5.02	5.6	μA
P <sub>(PLIM)</sub>	Max Output power	R <sub>(PLIM)</sub> = 100 kΩ		94	100	106	W
		R <sub>(PLIM)</sub> = 150 kΩ <sup>(1)</sup>		141.9	151	160.1	W
<b>PASS FET OUTPUT (OUT)</b>							
R <sub>ON</sub>	IN to OUT total ON resistance	0.6 A ≤ I <sub>(OUT)</sub> ≤ 6 A, T <sub>J</sub> = 25°C		26	30.44	34.5	mΩ
R <sub>ON</sub>	IN to OUT total ON resistance	0.6 A ≤ I <sub>(OUT)</sub> ≤ 6 A, T <sub>J</sub> = 85°C		33		45	mΩ
R <sub>ON</sub>	IN to OUT total ON resistance	0.6 A ≤ I <sub>(OUT)</sub> ≤ 6 A, –40°C ≤ T <sub>J</sub> ≤ +125°C		19	30.44	53	mΩ
<b>OUTPUT RAMP CONTROL (dVdT)</b>							
I <sub>(dVdT)</sub>	dVdT charging current	V <sub>(dVdT)</sub> = 0 V		1.775	2	2.225	μA
GAIN <sub>(dVdT)</sub>	dVdT to OUT gain	V <sub>(OUT)</sub> / V <sub>(dVdT)</sub>		23.5	25	26	V/V
V <sub>(dVdTmax)</sub>	dVdT maximum capacitor voltage	3.8	4.17	4.75	V		
R <sub>(dVdT)</sub>	dVdT discharging resistance	10	16.6	26.6	Ω		
<b>CURRENT MONITOR OUTPUT (IMON)</b>							
GAIN <sub>(IMON)</sub>	Gain factor I <sub>(IMON)</sub> :I <sub>(OUT)</sub>	0.6 A ≤ I <sub>(OUT)</sub> < 2 A		25.66	27.9	30.14	μA/A
		2 A ≤ I <sub>(OUT)</sub> ≤ 6 A		26.22	27.9	29.58	μA/A

(1) Parameter guaranteed by design and characterization, not tested in production

## Electrical Characteristics (continued)

$-40^{\circ}\text{C} \leq T_A = T_J \leq +125^{\circ}\text{C}$ ,  $4.5\text{ V} < V_{(IN)} = V_{(P\_IN)} < 60\text{ V}$ ,  $V_{(\overline{\text{SHDN}})} = 2\text{ V}$ ,  $R_{(LIM)} = 30\text{ k}\Omega$ ,  $\text{IMON} = \text{PGOOD} = \overline{\text{FLT}} = \text{OPEN}$ ,  $C_{(OUT)} = 1\text{ }\mu\text{F}$ ,  $C_{(dVdT)} = \text{OPEN}$ . (All voltages referenced to GND, (unless otherwise noted))

PARAMETER		TEST CONDITIONS	MIN	TYP	MAX	UNIT
<b>LOW IQ SHUTDOWN (<math>\overline{\text{SHDN}}</math>) INPUT</b>						
$V_{(\overline{\text{SHDN}})}$	Open circuit voltage	$I_{(\overline{\text{SHDN}})} = 0.1\text{ }\mu\text{A}$	2.48	2.7	3.3	V
$V_{(\text{SHUTF})}$	$\overline{\text{SHDN}}$ threshold voltage for low IQ shutdown, falling		0.8			V
$V_{(\text{SHUTR})}$	$\overline{\text{SHDN}}$ threshold rising				2	V
$I_{(\overline{\text{SHDN}})}$	Leakage current	$V_{(\overline{\text{SHDN}})} = 0\text{ V}$	-10			$\mu\text{A}$
<b>FAULT FLAG (<math>\overline{\text{FLT}}</math>): ACTIVE LOW</b>						
$R_{(\overline{\text{FLT}})}$	$\overline{\text{FLT}}$ Pull-down resistance		36	70	130	$\Omega$
$I_{(\overline{\text{FLT}})}$	$\overline{\text{FLT}}$ Input leakage current	$0\text{ V} \leq V_{(\overline{\text{FLT}})} \leq 60\text{ V}$	-150	6	150	nA
<b>POWER GOOD (PGOOD)</b>						
$R_{(\text{PGOOD})}$	PGOOD Pull-down resistance		36	70	130	$\Omega$
$I_{(\text{PGOOD})}$	PGOOD Input leakage current	$0\text{ V} \leq V_{(\text{PGOOD})} \leq 60\text{ V}$	-150	6	150	nA
<b>THERMAL PROTECTION</b>						
$T_{(\text{J\_REG})}$	Thermal regulation set point		136	145	154	$^{\circ}\text{C}$
$T_{(\text{TSD})}$	Thermal shutdown (TSD) threshold, rising			165		$^{\circ}\text{C}$
$T_{(\text{TSDhyst})}$	TSD hysteresis			11		$^{\circ}\text{C}$
<b>MODE</b>						
MODE_SEL	Mode selection	MODE = Open		Latch		
		MODE = Short to GND		Auto – Retry		

## 7.6 Timing Requirements

$-40^{\circ}\text{C} \leq T_A = T_J \leq +125^{\circ}\text{C}$ ,  $4.5\text{ V} < V_{(IN)} = V_{(P\_IN)} < 60\text{ V}$ ,  $V_{(\overline{\text{SHDN}})} = 2\text{ V}$ ,  $R_{(LIM)} = 30\text{ k}\Omega$ ,  $\text{IMON} = \text{PGOOD} = \overline{\text{FLT}} = \text{OPEN}$ ,  $C_{(OUT)} = 1\text{ }\mu\text{F}$ ,  $C_{(dVdT)} = \text{OPEN}$ . (All voltages referenced to GND, (unless otherwise noted))

PARAMETER		TEST CONDITIONS	MIN	NOM	MAX	UNIT
<b>UVLO INPUT (UVLO)</b>						
$\text{UVLO\_}t_{\text{on}}(\text{dly})$	UVLO switch turnon delay	$\text{UVLO}\uparrow$ (100 mV above $V_{(\text{UVLOR})}$ ) to $V_{(\text{OUT})} = 100\text{ mV}$ , $C_{(dVdT)} \geq 10\text{ nF}$ , [ $C_{(dVdT)}$ in nF]		742 + 49.5 x $C_{(dVdT)}$		$\mu\text{s}$
$\text{UVLO\_}t_{\text{off}}(\text{dly})$	UVLO switch turnoff delay	$\text{UVLO}\downarrow$ (20 mV below $V_{(\text{UVLOF})}$ ) to $\overline{\text{FLT}}\downarrow$	9	11	16	$\mu\text{s}$
$t_{\text{UVLO\_FLT}}(\text{dly})$	UVLO to Fault de-assertion delay	$\text{UVLO}\uparrow$ to $\overline{\text{FLT}}\uparrow$ delay	500	617	700	$\mu\text{s}$
<b>OVER VOLTAGE PROTECTION INPUT (OVP)</b>						
$\text{OVP\_}t_{\text{off}}(\text{dly})$	OVP switch turnOFF delay	$\text{OVP}\uparrow$ (20 mV above $V_{(\text{OVPR})}$ ) to $\overline{\text{FLT}}\downarrow$	8.5	11	14	$\mu\text{s}$
$\text{OVP\_}t_{\text{on}}(\text{dly})$	OVP switch disable delay	$\text{OVP}\downarrow$ (100 mV below $V_{(\text{OVPF})}$ ) to FET ON, $C_{(dVdT)} \geq 10\text{ nF}$ , [ $C_{(dVdT)}$ in nF]		150 + 49.5 x $C_{(dVdT)}$		$\mu\text{s}$
$t_{\text{OVC}}(\text{dly})$	Maximum duration in over voltage clamp operation	TPS16632 Only		162		ms
$\text{OVC\_}t_{\text{FLT}}(\text{dly})$	$\overline{\text{FLT}}$ assertion delay in over voltage clamp operation	TPS16632 Only		617		$\mu\text{s}$
<b>SHUTDOWN CONTROL INPUT (<math>\overline{\text{SHDN}}</math>)</b>						
$t_{\text{SD}}(\text{dly})$	SHUTDOWN entry delay	$\overline{\text{SHDN}}\downarrow$ (below $V_{(\text{SHUTF})}$ ) to FET OFF	0.8	1	1.5	$\mu\text{s}$
<b>CURRENT LIMIT</b>						
$t_{\text{FASTTRIP}}(\text{dly})$	Hot-short response time	$I_{(\text{OUT})} > I_{(\text{SCP})}$		1		$\mu\text{s}$
	Soft short response	$I_{(\text{FASTTRIP})} < I_{(\text{OUT})} < I_{(\text{SCP})}$	2.2	3.2	4.5	$\mu\text{s}$
$t_{\text{CL\_PLIM}}(\text{dly})$	Maximum duration in current & (power limiting: TPS16632 Only)		129	162	202	ms



## Timing Requirements (continued)

$-40^{\circ}\text{C} \leq T_A = T_J \leq +125^{\circ}\text{C}$ ,  $4.5\text{ V} < V_{(IN)} = V_{(P\_IN)} < 60\text{ V}$ ,  $V_{(\overline{\text{SHDN}})} = 2\text{ V}$ ,  $R_{(ILIM)} = 30\text{ k}\Omega$ ,  $\text{IMON} = \text{PGOOD} = \overline{\text{FLT}} = \text{OPEN}$ ,  $C_{(OUT)} = 1\text{ }\mu\text{F}$ ,  $C_{(dVdT)} = \text{OPEN}$ . (All voltages referenced to GND, (unless otherwise noted))

PARAMETER		TEST CONDITIONS	MIN	NOM	MAX	UNIT
$t_{\text{CL\_PLIM\_FLT(dly)}}$	FLT delay in current & (power limiting: TPS16632 Only)		1.09	1.3	1.6	ms
<b>OUTPUT RAMP CONTROL (dVdT)</b>						
$t_{(\text{FASTCHARGE})}$	Output ramp time in fast charging	$C_{(dVdT)} = \text{Open}$ , 10% to 90% $V_{(OUT)}$ , $C_{(OUT)} = 1\text{ }\mu\text{F}$ ; $V_{(IN)} = 24\text{ V}$	350	495	700	$\mu\text{s}$
$t_{(dVdT)}$	Output ramp time	$C_{(dVdT)} = 22\text{ nF}$ , 10% to 90% $V_{(OUT)}$ , $V_{(IN)} = 24\text{ V}$		8.35		ms
<b>POWER GOOD (PGOOD)</b>						
$t_{\text{PGOODR}}$	PGOOD delay (deglitch) time	Rising edge	8	11.5	13	ms
$t_{\text{PGOODF}}$	PGOOD delay (deglitch) time	Falling edge	8	10	13	ms
<b>THERMAL PROTECTION</b>						
$t_{(\text{TSD\_retry})}$	Retry delay in TSD	MODE = GND	500	648	800	ms
$t_{(\text{Treg\_timeout})}$	Thermal Regulation Timeout		1.1	1.25	1.5	s

## 7.7 Typical Characteristics

$-40^{\circ}\text{C} \leq T_A = T_J \leq +125^{\circ}\text{C}$ ,  $V_{(IN)} = V_{(P\_IN)} = 24\text{ V}$ ,  $V_{(\overline{\text{SHDN}})} = 2\text{ V}$ ,  $R_{(ILIM)} = 30\text{ k}\Omega$ ,  $\text{IMON} = \text{PGOOD} = \overline{\text{FLT}} = \text{OPEN}$ ,  $C_{(OUT)} = 1\text{ }\mu\text{F}$ ,  $C_{(dVdT)} = \text{OPEN}$ . (Unless stated otherwise)

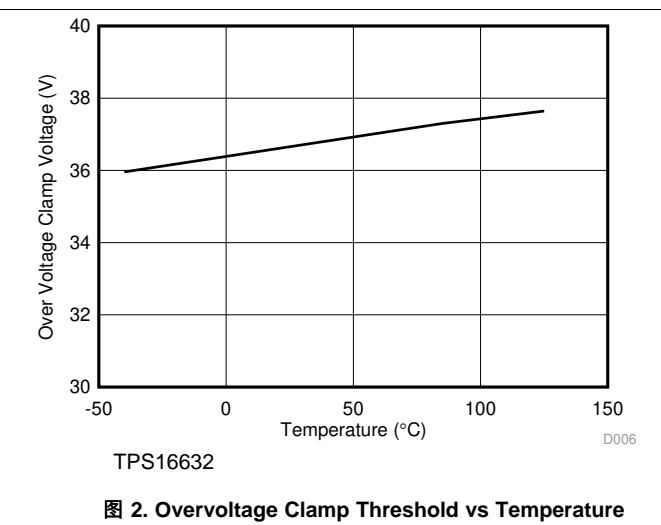
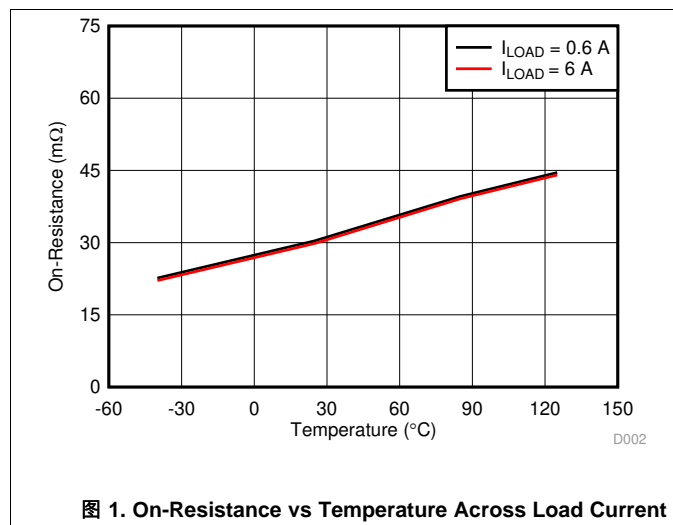

Typical Characteristics (接下页)

$-40^{\circ}\text{C} \leq T_A = T_J \leq +125^{\circ}\text{C}$ ,  $V_{(IN)} = V_{(P\_IN)} = 24\text{ V}$ ,  $V_{(\overline{\text{SHDN}})} = 2\text{ V}$ ,  $R_{(ILIM)} = 30\text{ k}\Omega$ ,  $\text{IMON} = \text{PGOOD} = \overline{\text{FLT}} = \text{OPEN}$ ,  $C_{(OUT)} = 1\text{ }\mu\text{F}$ ,  $C_{(dVdT)} = \text{OPEN}$ . (Unless stated otherwise)



图 3. Input Supply Current vs Supply Voltage in Shutdown



图 4. Input Supply Current vs Supply Voltage During Normal Operation

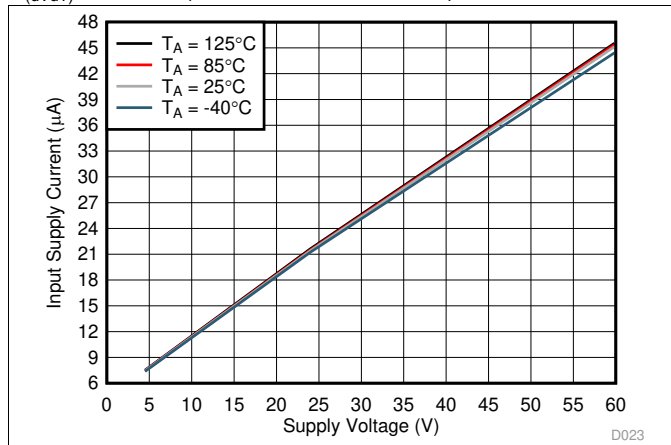

图 5. Overload Current Limit vs Temperature

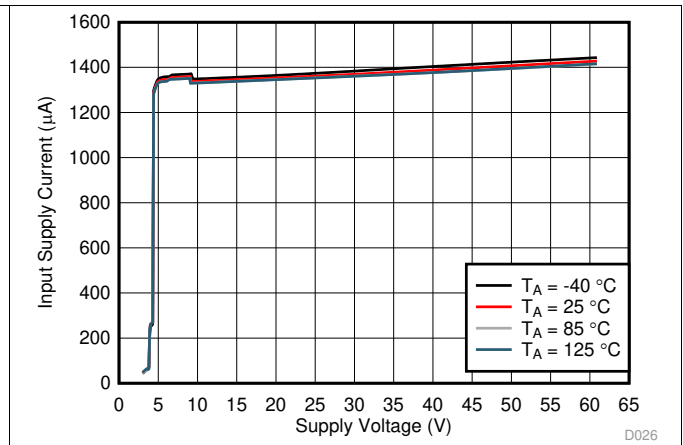

图 6. Overload Current Limit vs Temperature

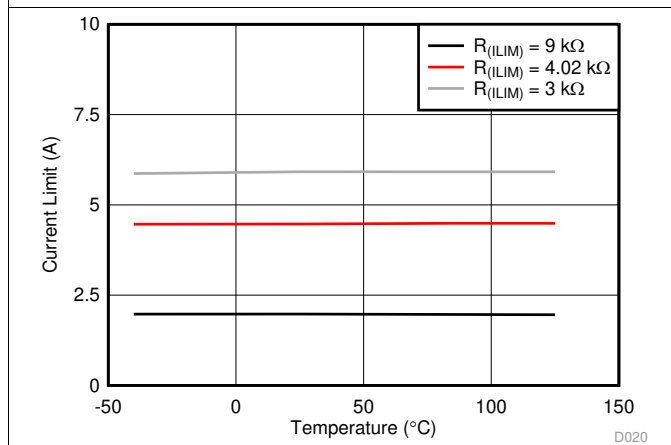

图 7. Output Power Limiting Accuracy vs PLIM

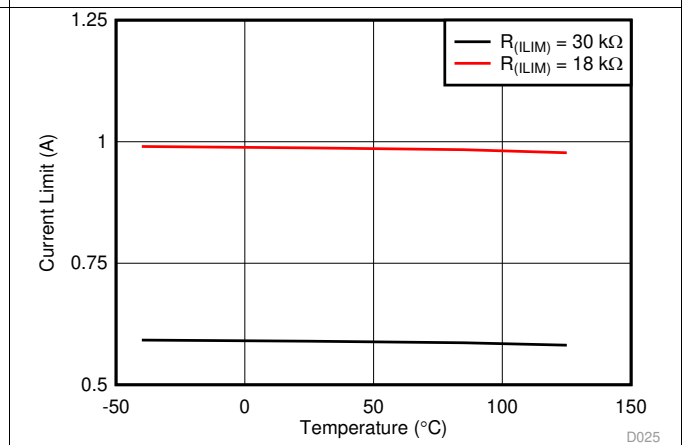

图 8. Power Limit, Current Limit vs Supply Voltage

Typical Characteristics (接下页)

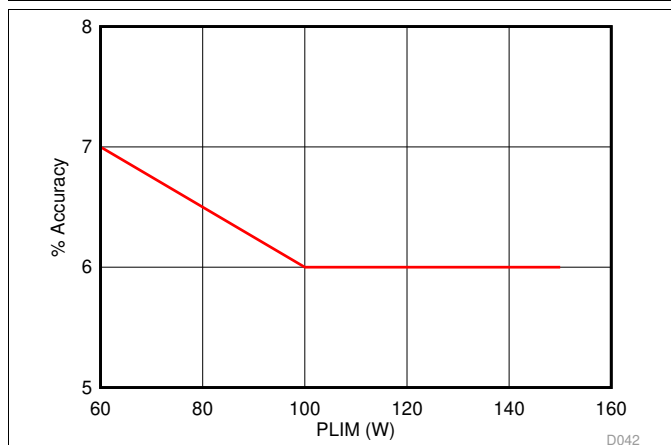
$-40^{\circ}\text{C} \leq T_A = T_J \leq +125^{\circ}\text{C}$ ,  $V_{(IN)} = V_{(P\_IN)} = 24\text{ V}$ ,  $V_{(\overline{\text{SHDN}})} = 2\text{ V}$ ,  $R_{(ILIM)} = 30\text{ k}\Omega$ ,  $\text{IMON} = \text{PGOOD} = \overline{\text{FLT}} = \text{OPEN}$ ,  $C_{(OUT)} = 1\text{ }\mu\text{F}$ ,  $C_{(dVdT)} = \text{OPEN}$ . (Unless stated otherwise)

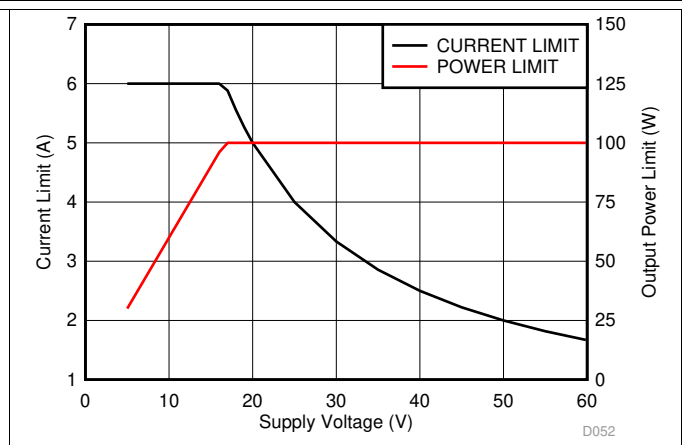

图 9. Current Monitor Output vs Output Current



图 10. IMON Gain Accuracy at Low Output Current Levels

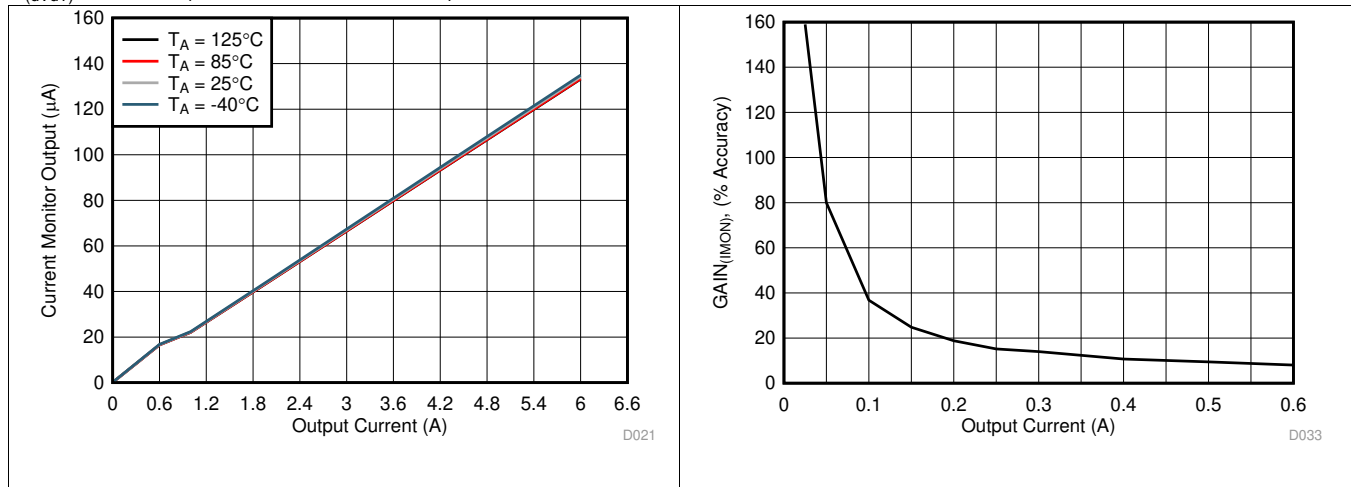

图 11. Maximum Duration in Current and Power Limiting vs Temperature

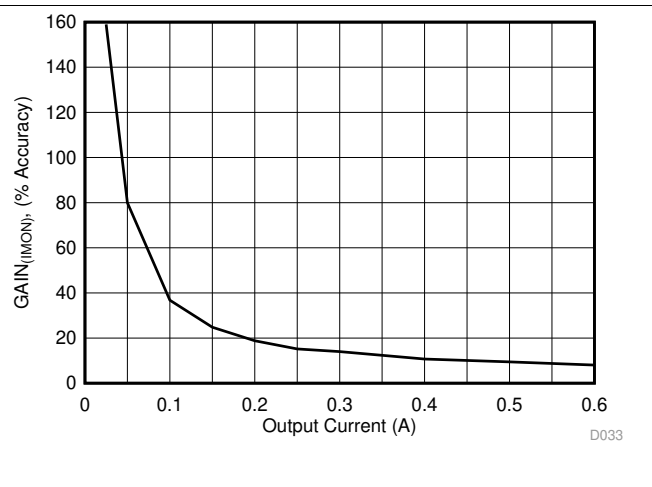

图 12. PGOOD Rising and Falling Delay vs Temperature

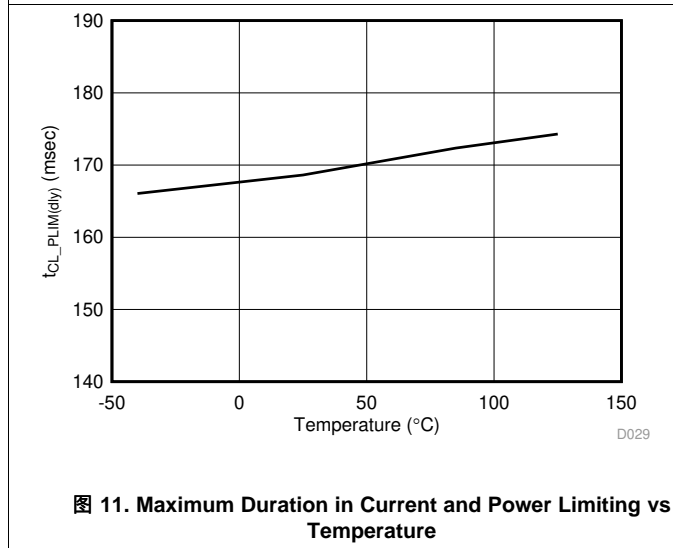

图 13. Thermal Shutdown Time vs Power Dissipation

## 8 Parameter Measurement Information

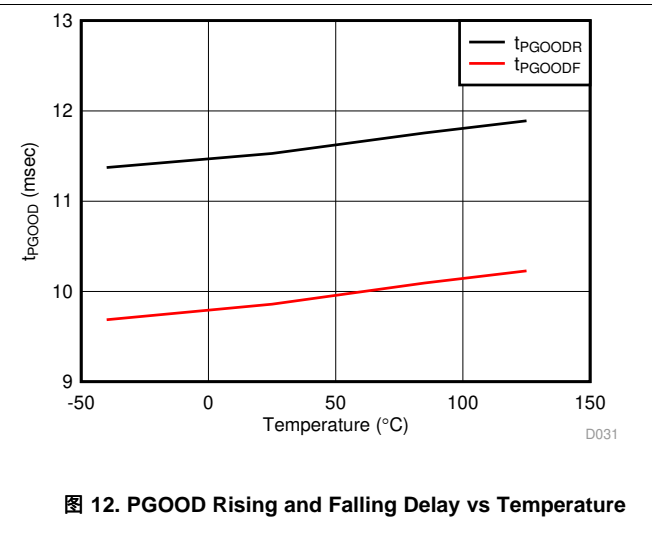

图 14. Timing Waveforms

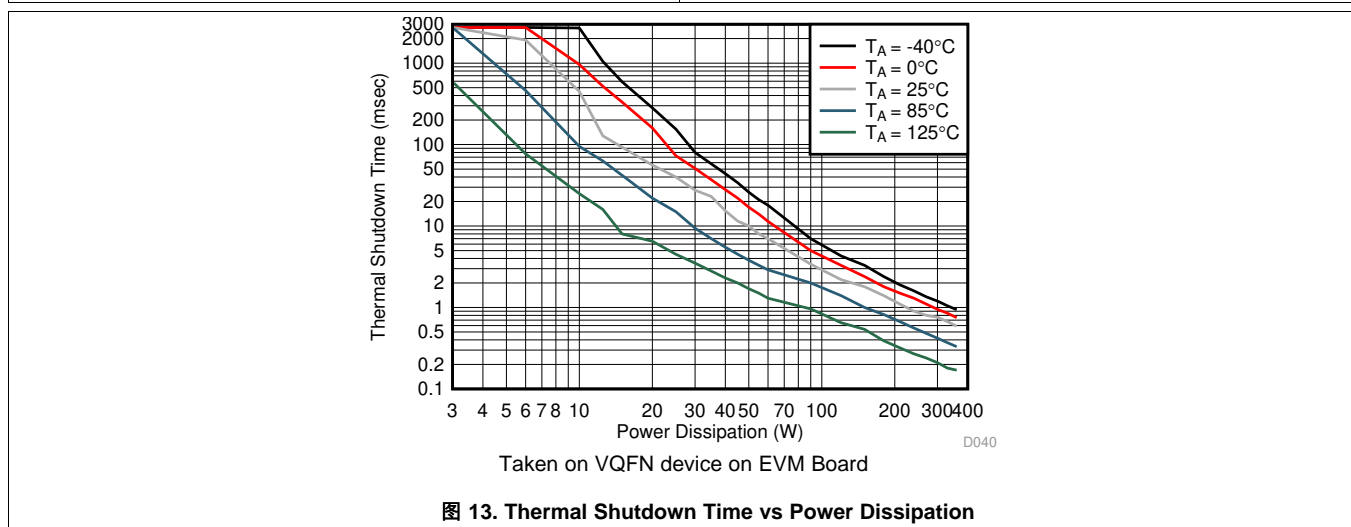
## 9 Detailed Description

### 9.1 Overview

The TPS1663x is a family of 60-V industrial eFuses. It provides robust protection for all systems and applications powered from 4.5 V to 60 V. For hot-pluggable boards, the device provides hot-swap power management with in-rush current control and programmable output voltage slew rate features using the dVdT pin. Load, source and device protections are provided with many programmable features including overcurrent, overvoltage and undervoltage. The 60-V maximum DC operating and 62-V absolute maximum voltage rating enables system protection from 60-V DC input supply faults from industrial SELV power supplies. The precision overcurrent limit ( $\pm 7\%$  at 6 A) helps to minimize over design of the input power supply, while the fast response short circuit protection  $1\mu\text{s}$  (typical) immediately isolates the faulty load from the input supply when a short circuit is detected.

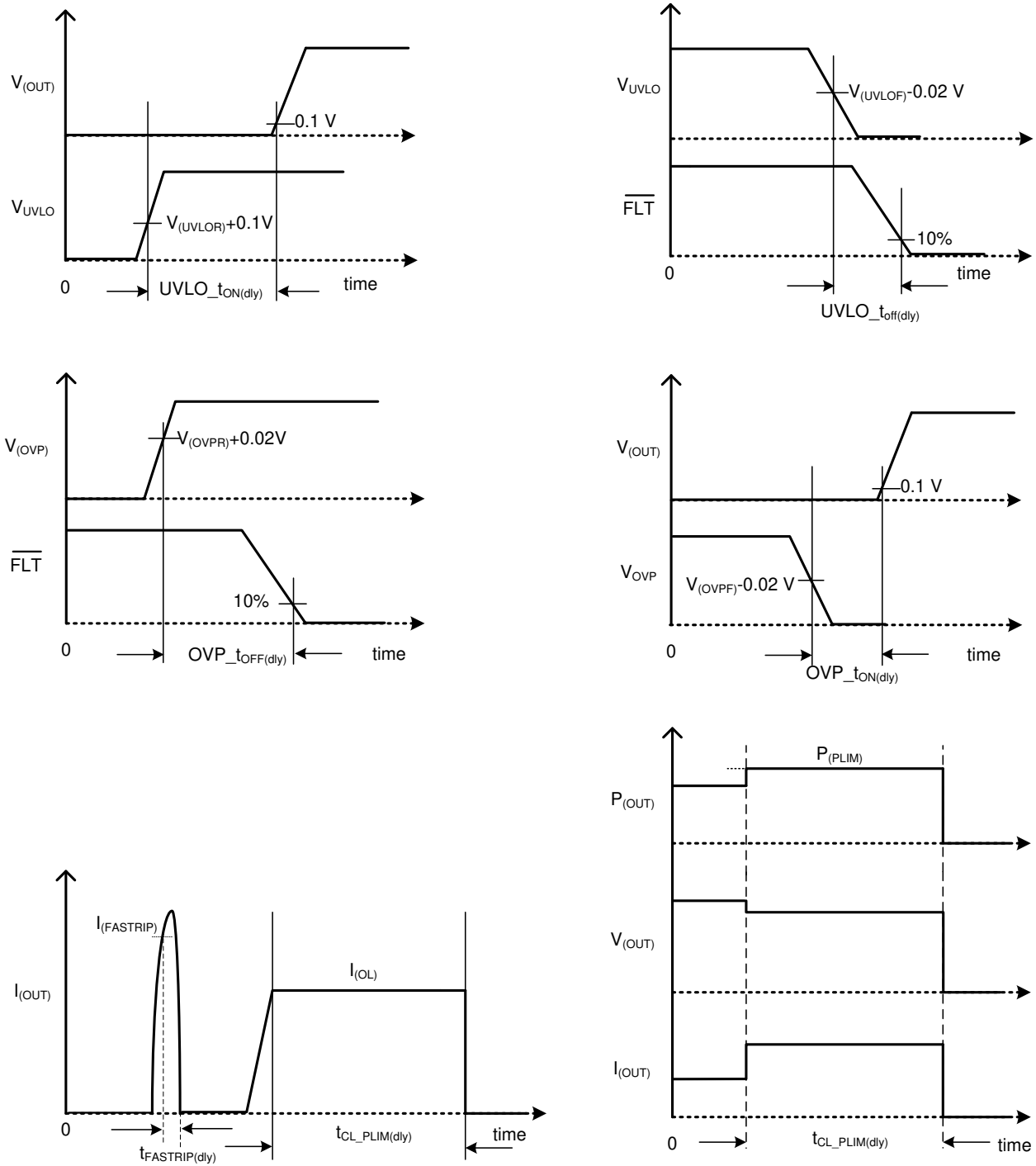
The TPS16632 device integrate adjustable output power limiting (PLIM) functionality that simplifies the system design requiring compliance in accordance to standards like IEC61010-1 and UL1310.

The device provides precise monitoring of voltage bus for brown-out and overvoltage conditions and asserts fault signal for the downstream system. Its overall threshold accuracy of 2% ensures tight supervision of bus, eliminating the need for a separate supply voltage supervisor chip.

Additional features of the TPS1663x include:

- $\pm 6\%$  current monitor output (IMON) for health monitoring of the system
- A choice of latch off or automatic restart mode response during current limit, Power Limit and thermal fault using MODE pin
- PGOOD indicator output
- Over temperature protection to safely shutdown in the event of an overcurrent event
- De-glitched fault reporting for supply brown-out and overvoltage faults
- Enable/Disable control from an MCU using  $\overline{\text{SHDN}}$  pin

## 9.2 Functional Block Diagram

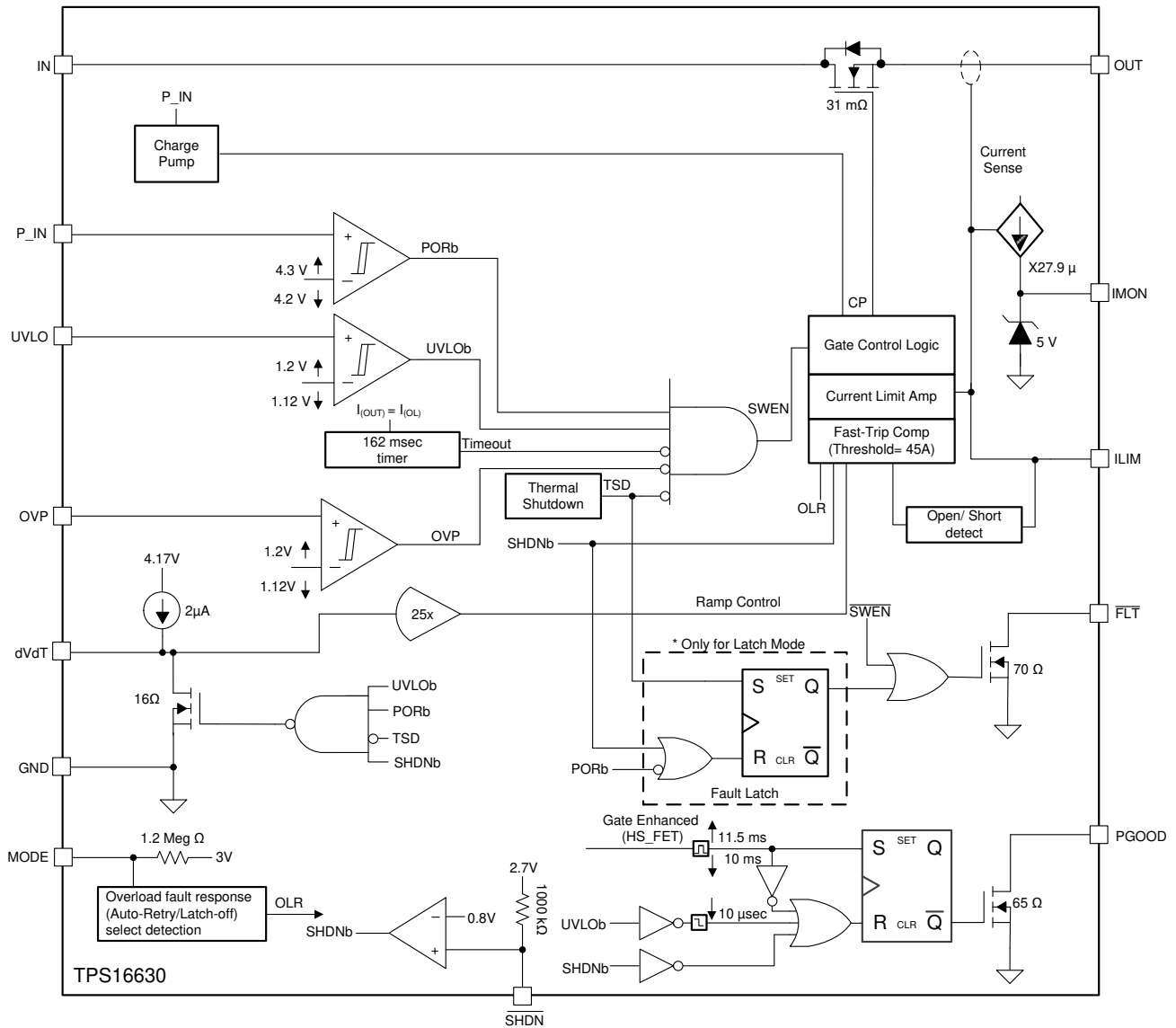

Functional Block Diagram (接下页)

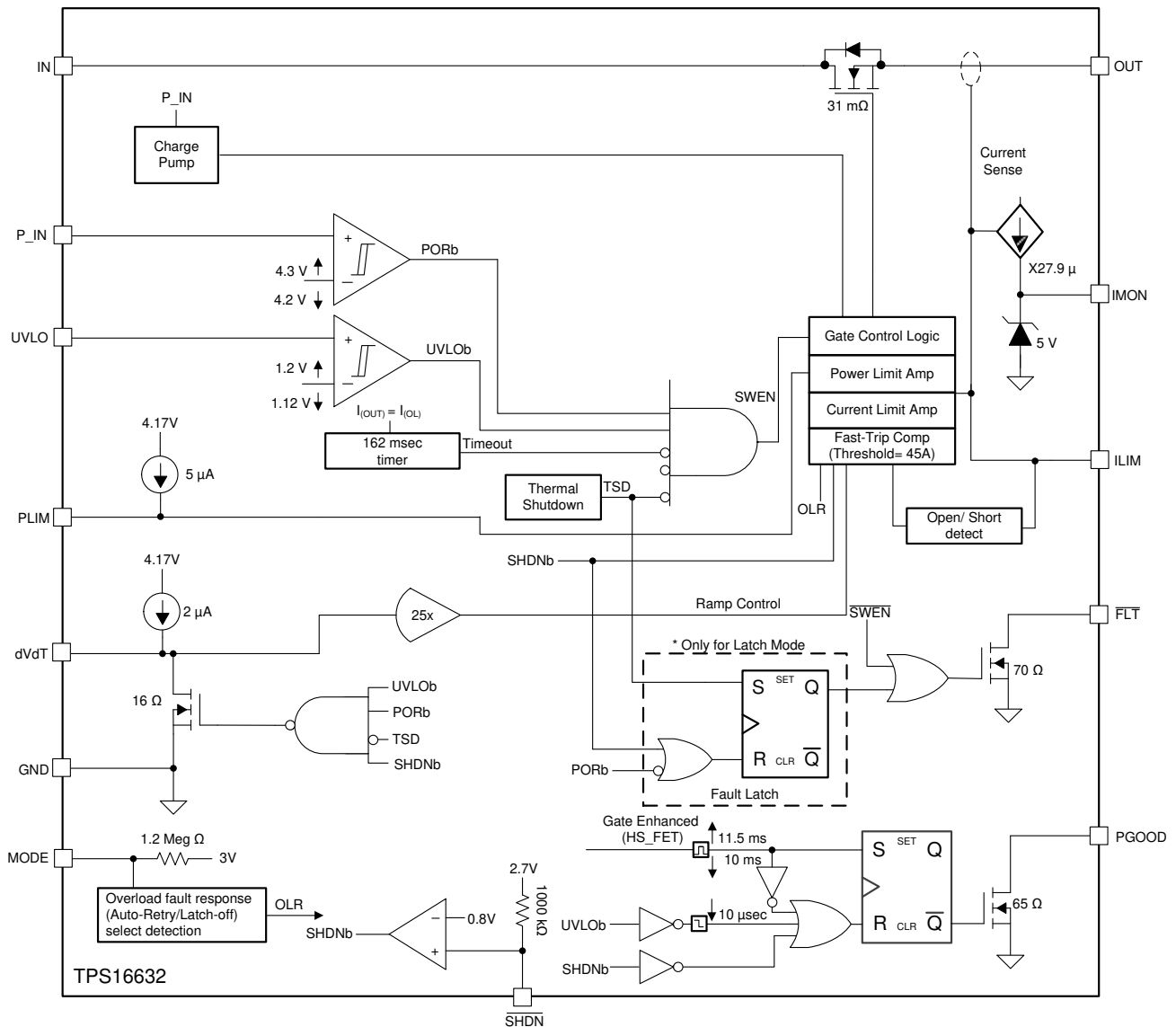

9.3 Feature Description

9.3.1 Hot Plug-In and In-Rush Current Control

The devices are designed to control the inrush current upon insertion of a card into a live backplane or other "hot" power source. This limits the voltage sag on the backplane's supply voltage and prevents unintended resets of the system power. The controlled start-up also helps to eliminate conductive and radiative interferences. An external capacitor connected from the dVdT pin to GND defines the slew rate of the output voltage at power-on. The fastest output slew rate of 24V/500 µs can be achieved by leaving dVdT pin floating. The inrush current can be calculated using 公式 1.

$$I = C \times \frac{dV}{dT} \geq I(INRUSH) = C(OUT) \times \frac{V(IN)}{t_{dVdT}} \tag{1}$$

where

$$t_{dVdT} = 20.8 \times 10^3 \times V(IN) \times C_{(dVdT)} \tag{2}$$

图 15 illustrates in-rush current control performance of the device during Hot Plug-In.

Feature Description (接下页)

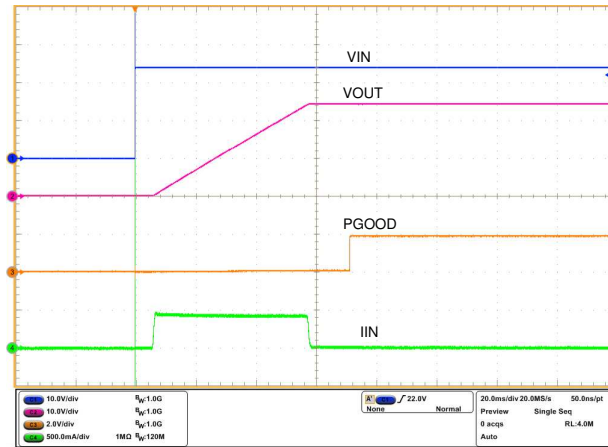

$$C_{dVdT} = 100 \text{ nF} \quad C_{OUT} = 1000 \text{ } \mu\text{F} \quad R_{ILIM} = 4.02 \text{ k}\Omega$$

图 15. Hot Plug In and Inrush Current Control at 24-V Input

9.3.1.1 Thermal Regulation Loop

The average power dissipation within the eFuse during power up with a capacitive load can be calculated using 公式 3.

$$PD(INRUSH) = 0.5 \times V_{(IN)} \times I(INRUSH) \tag{3}$$

System designs requiring to charge large output capacitors rapidly may result in an operating point that exceeds the power dissipation versus time boundary limits of the device defined by 图 13 characteristic curve. This may result in increase in junction temperature beyond the device's maximum allowed junction temperature. To keep the junction temperature within the operating range, the thermal regulation control loop regulates the junction temperature at  $T_{(J\_REG)}$ , 145°C (typical) by controlling the inrush current profile and thereby limiting the power dissipation within the device automatically. An internal 1.25 sec (typical),  $t_{(Treg\_timeout)}$  timer starts from the instance the thermal regulation operation kicks in. If the output does not power up within this time then the internal FET is turned OFF. Subsequent operation of the device depends on the MODE configuration (Auto-Retry or latch OFF) setting as per the 表 1. The maximum time-out of 1.25 sec (typical) in thermal regulation loop operation ensures that the device and the system board does not heat up during steady fault conditions such as wake up with output short-circuit. This scheme ensures reliable power up operation.

Thermal regulation control loop is internally enabled during power up by  $V_{(IN)}$ , UVLO cycling and turn ON using  $\overline{SHDN}$  control. 图 16 illustrates performance of the device operating in thermal regulation loop during power up by  $V_{(IN)}$  with a large output capacitor. The Thermal regulation loop gets disabled internally after the power up sequence when the internal FET's gate gets fully enhanced or when the  $t_{(Treg\_timeout)}$  of 1.25 sec (typical) time is elapsed.



Feature Description (接下页)

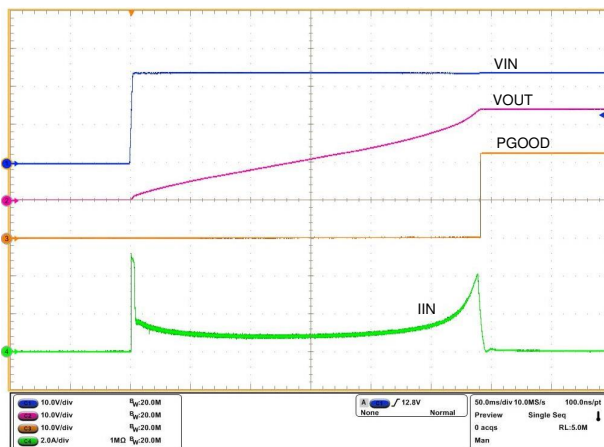

$$C_{dVdT} = \text{Open} \quad C_{OUT} = 15 \text{ mF} \quad R_{ILIM} = 4.02 \text{ k}\Omega$$

图 16. Thermal Regulation Loop Response During Power up with Large Capacitive Load

9.3.2 Undervoltage Lockout (UVLO)

The TPS1663x devices feature an accurate  $\pm 2\%$  adjustable undervoltage lockout functionality. When the voltage at UVLO pin falls below  $V_{(UVLOF)}$  during input undervoltage fault, the internal FET quickly turns off and  $\overline{\text{FLT}}$  is asserted. The UVLO comparator has a hysteresis of 78 mV (typical). To set the input UVLO threshold, connect a resistor divider network from IN supply to UVLO terminal to GND as shown in 图 17. If the Under-Voltage Lock-Out function is not needed, the UVLO terminal must be connected to the IN terminal. UVLO terminal must not be left floating.



图 17. UVLO and OVP Thresholds Set by  $R_1$ ,  $R_2$  and  $R_3$

## Feature Description (接下页)

### 9.3.3 Overvoltage Protection (OVP)

The TPS1663x incorporate circuitry to protect the system during overvoltage conditions. The TPS16630 features an accurate  $\pm 2\%$  adjustable over voltage cut off functionality. A voltage more than  $V_{(OVPR)}$  on OVP pin turns off the internal FET and protects the downstream load. To program the OVP threshold externally, connect a resistor divider from IN supply to OVP terminal to GND as shown in 图 17. The TPS16632 features an internally fixed 39 V maximum overvoltage clamp  $V_{(OVC)}$  functionality. The TPS16632 clamps the output voltage to  $V_{(OVC)}$ , when the input voltage exceeds 40 V. During the output voltage clamp operation, the power dissipation in the internal MOSFET is  $PD = (V_{(IN)} - V_{(OVC)}) \times I_{(OUT)}$ . Excess power dissipation for a prolonged period can increase the device temperature. To avoid this, the internal FET is operated in overvoltage clamp for a maximum duration of  $t_{OVC(dly)}$ , 162 msec (typical). After this duration, the internal FET is turned OFF and the subsequent operation of the device depends on the MODE configuration (Auto-Retry or latch OFF) setting as per the 表 1.

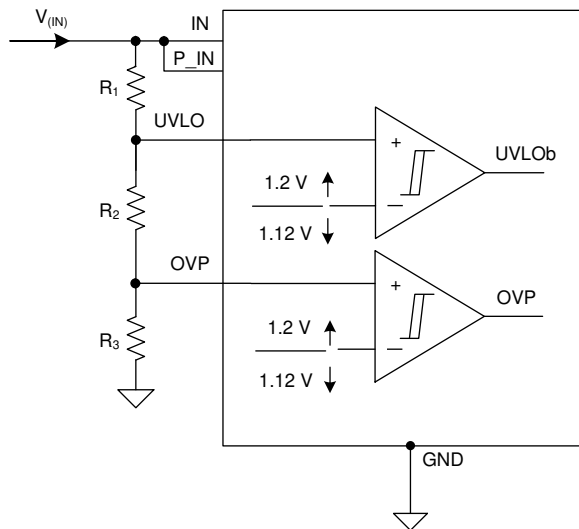
图 18 illustrates the overvoltage cut-off functionality and 图 19 illustrates the overvoltage clamp functionality.  $\overline{FLT}$  is asserted after a delay of 617  $\mu s$  (typical) after entering in overvoltage clamp mode and remains asserted until the overvoltage fault is removed.

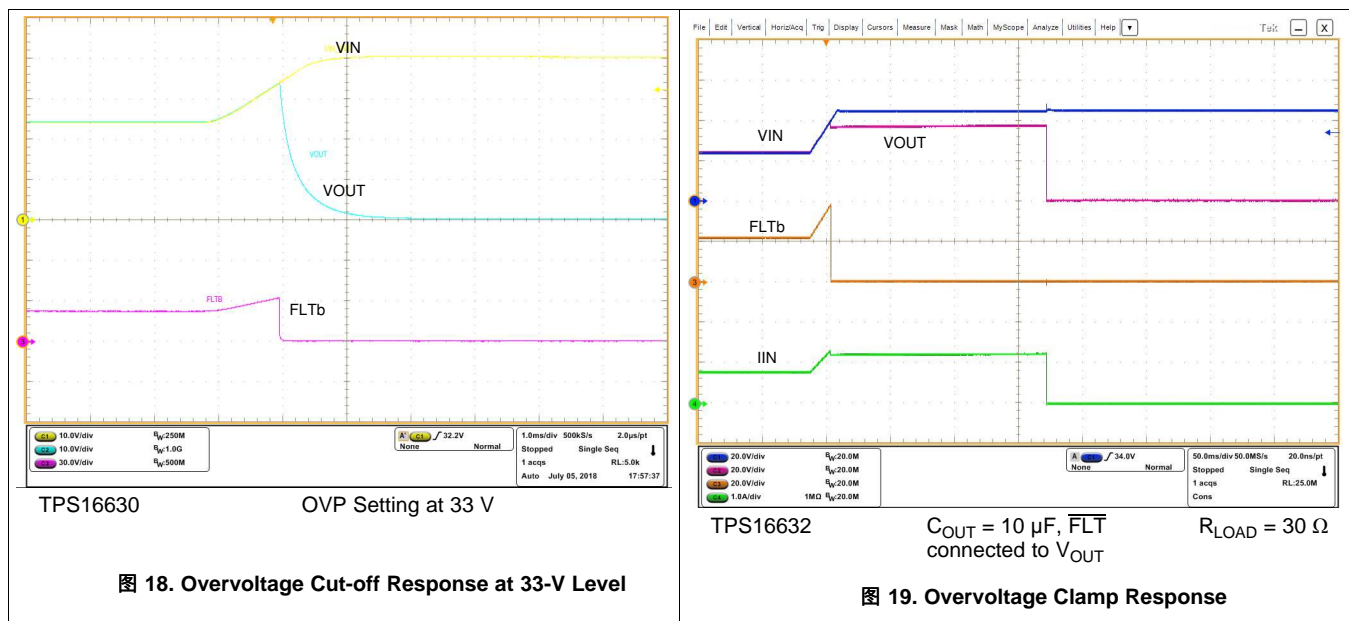

### 9.3.4 Overload and Short Circuit Protection

The device monitors the load current by sensing the voltage across the internal sense resistor. The FET current is monitored during start-up and normal operation.

#### 9.3.4.1 Overload Protection

The TPS1663x devices feature accurate overload current limiting and fast short circuit protection feature. If the load current exceeds the programmed current limit  $I_{OL}$ , the device regulates the current through it at  $I_{OL}$  eventually reducing the output voltage. The power dissipation across the device during this operation will be  $(V_{IN} - V_{OUT}) \times I_{OL}$  and this could heat up the device and eventually enter into thermal shutdown. The maximum duration for the over current through the FET is  $t_{CL\_PLIM(dly)}$ , 162 msec (typical). If the thermal shutdown occurs before this time the internal FET turns OFF and the device operates either in auto-retry or latch off mode based on MODE pin configuration in 表 1. Set the current limit using 公式 4

$$I_{OL} = \frac{18}{R_{(ILIM)}}$$

where

- $I_{(OL)}$  is the overload current limit in Ampere

## Feature Description (接下页)

- $R_{(ILIM)}$  is the current limit resistor in  $k\Omega$  (4)

During the overload current limiting if the overload condition exists for more than  $t_{CL\_PLIM\_FLT(dly)}$ , 1.3 msec (typical), the  $\overline{FLT}$  asserts to warn of impending turnoff of the internal FETs due to the subsequent thermal shutdown event or due to  $t_{CL\_PLIM(dly)}$  timer expiry. The  $\overline{FLT}$  signal remains asserted until the fault condition is removed and the device resumes normal operation. 图 20 和 图 21 illustrate Overload current limiting performance.

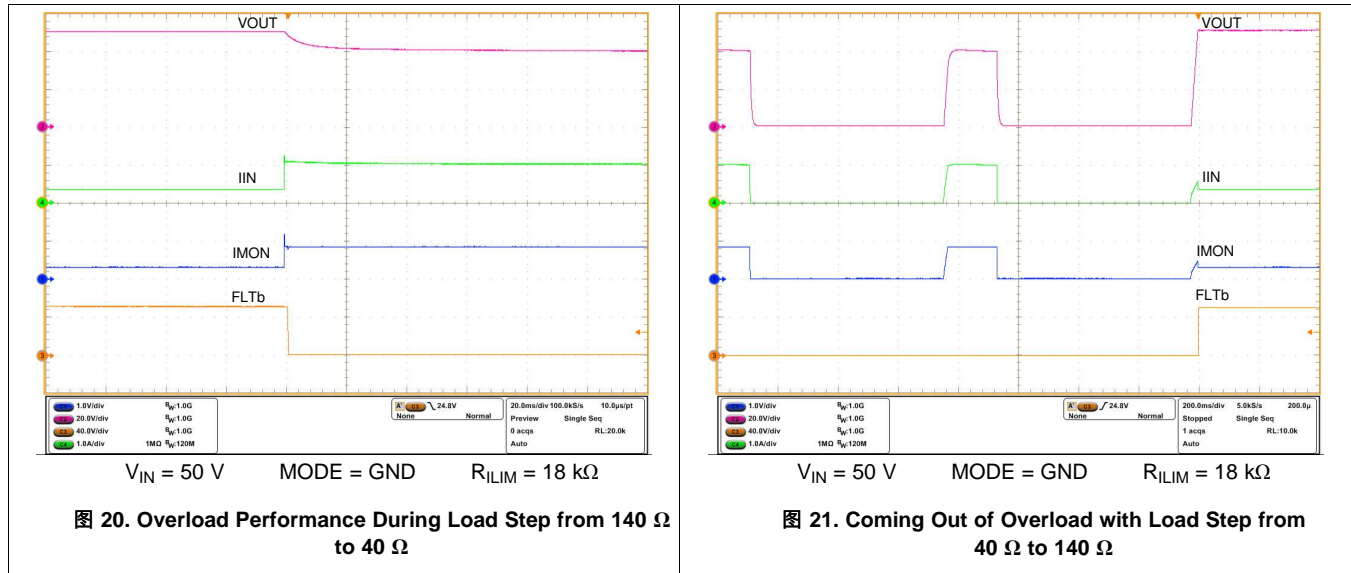

The TPS1663x devices feature ILIM pin short and open fault detection and protection. The internal FET is turned OFF when ILIM pin is detected short or open to GND and it remains OFF till the ILIM pin fault is removed.

### 9.3.4.2 Short Circuit Protection

During a transient output short circuit event, the current through the device increases rapidly. As the current-limit amplifier cannot respond quickly to this event due to its limited bandwidth, the device incorporates a fast-trip comparator. The fast-trip comparator architecture is designed for fast turn OFF  $t_{FASTTRIP(dly)} = 1 \mu s$  (typical) with  $I_{(SCP)} = 45 A$  of the internal FET during an output short circuit event. The fast-trip threshold is internally set to  $I_{(FASTTRIP)}$ . The fasttrip circuit holds the internal FET off for only a few microseconds, after which the device turns back on slowly, allowing the current-limit loop to regulate the output current to  $I_{(OL)}$ . Then the device functions similar to the overload condition. 图 22 illustrates output hot-short performance of the device.

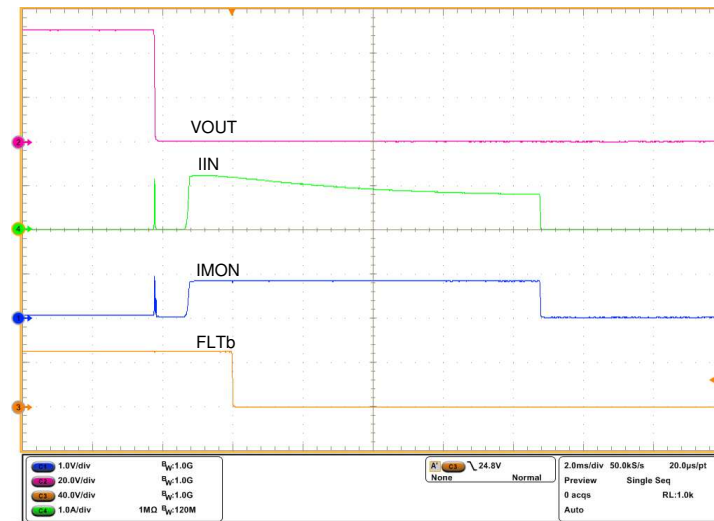
**Feature Description (接下页)**

$$V_{IN} = 50 \text{ V}$$

$$R_{LIM} = 18 \text{ k}\Omega$$

**图 22. Output Hot-Short Response**

The fast-trip comparator architecture has a supply line noise immunity resulting in a robust performance in noisy environments. This is achieved by controlling the turn OFF time of the internal FET based on the overcurrent level,  $I_{(FASTTRIP)}$  through the device. Higher the overcurrent, faster the turn OFF time,  $t_{FASTTRIP(dly)}$ . At Overload current level in the range of  $I_{FASTTRIP} < I_{OUT} < I_{SCP}$  the fast-trip comparator response is 3.2  $\mu\text{s}$  (typical).

**9.3.4.2.1 Start-Up With Short-Circuit On Output**

When the device is started with short-circuit on the output, the current begins to limit at  $I_{(OL)}$ . Due to high power dissipation of  $V_{IN} \times I_{(OL)}$  within the device the junction temperature increases. Subsequently, the thermal regulation control loop limits the load current to regulate the junction temperature at  $T_{(J\_REG)}$ , 145°C (typical) for a duration of  $t_{(Treg\_timeout)}$ , 1.25 sec (typical). Subsequent operation of the device depends on the MODE configuration (Auto-Retry or latch OFF) setting as per the 表 1.  $\overline{FLT}$  gets asserted after  $t_{(Treg\_timeout)}$  and remains asserted till the output short-circuit is removed. 图 23 illustrates the behavior of the device in this condition.

Feature Description (接下页)

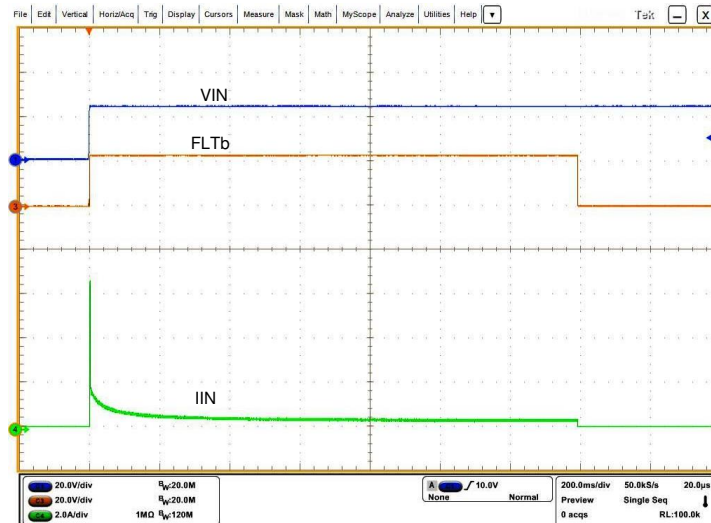

(1)

$$V_{IN} = 24 \text{ V}$$

$$R_{LIM} = 3 \text{ k}\Omega$$

图 23. Start-Up With Short on Output

9.3.5 Output Power Limiting, PLIM (TPS16632 Only)

In TPS16630, with a fixed overcurrent limit threshold the maximum output power limit increases linearly with supply input. Electrical Industrial process control equipment such as PLC CPU needs to comply with standards like IEC61010-1 and UL1310 for fire safety which require limited energy and power circuits. Limiting the output power becomes a challenge in such high power applications where the operating supply voltage range is wide. The TPS16632 integrate adjustable output power limiting functionality that simplifies the system design requiring compliance in accordance to this standard.

Connect a resistor from PLIM to GND as shown in 图 24 to set the output power limiting value. If output power limiting is not required then connect PLIM to GND directly. This disables the PLIM functionality.

During an over power load event the TPS16632 limits the output power at the programmed value set by PLIM resistor. This indirectly results in the device operation in current limiting mode with steady state output voltage and current set by the load characteristics and  $P_{LIM} = V_{OUT} \times I_{OUT}$ . 图 8 shows the output power limit and current limiting characteristics of TPS16632 with 100 W power limit setting. The maximum duration for the device in power limiting mode is 162 msec (typical),  $t_{CL\_PLIM(dly)}$ . After this time, the device operates either in auto-retry or latch off mode based on MODE pin configuration in 表 1.

$$P_{(PLIM)} = 1 \times R_{(PLIM)} \tag{5}$$

Here  $P_{(PLIM)}$  is output power limit in watts,  $R_{(PLIM)}$  is the power limit setting resistor in kΩ.

During the output power limiting operation,  $\overline{FLT}$  asserts after a delay of  $t_{CL\_PLIM\_FLT(dly)}$ . The  $\overline{FLT}$  signal remains asserted until the over power load condition is removed and the device resumes normal operation.

图 25 illustrate output power limiting performance of TPS16632 with 100 W setting for class-2 power supply designs .

Feature Description (接下页)



图 24. TPS16632 Typical Application Schematic



(1)

$R_{PLIM} = 100\text{ k}\Omega$                        $R_{ILIM} = 3\text{ k}\Omega$   
 图 25. 100 W class 2, Output Power Limiting Response of TPS16632

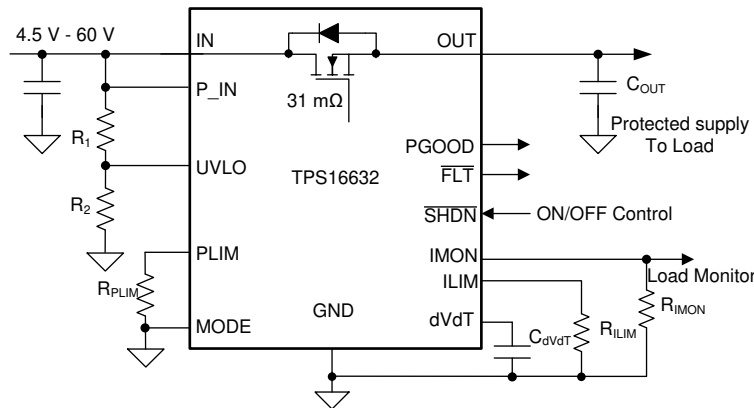
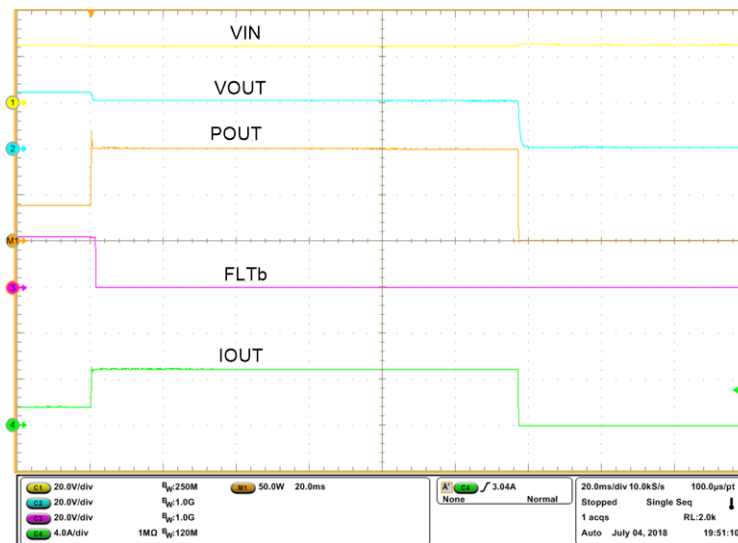
9.3.6 Current Monitoring Output (IMON)

The TPS1663x devices feature an accurate analog current monitoring output. A current source at IMON terminal is internally configured to be proportional to the current flowing from IN to OUT. This current can be converted into a voltage using a resistor  $R_{(IMON)}$  from IMON terminal to GND terminal. The IMON voltage can be used as a means of monitoring current flow through the system. The maximum voltage ( $V_{(IMONmax)}$ ) for monitoring the current is limited to 4 V. This puts a limitation on maximum value of  $R_{(IMON)}$  resistor and is determined by 公式 6.

$$V_{(IMON)} = [I_{(OUT)} \times GAIN_{(IMON)}] \times R_{(IMON)}$$

Where,

- $GAIN_{(IMON)}$  is the gain factor  $I_{(IMON)}:I_{(OUT)} = 27.9\mu\text{A/A}$  (Typical)
- $I_{(OUT)}$  is the load current

(6)

Refer to 图 9 for IMON output versus load current plot. 图 26 illustrates IMON performance.

## Feature Description (接下页)



图 26. IMON Response During a Load Step

The IMON pin must not have a bypass capacitor to avoid delay in the current monitoring information.

### 9.3.7 FAULT Response ( $\overline{\text{FLT}}$ )

The  $\overline{\text{FLT}}$  open-drain output asserts (active low) under the faults events such as undervoltage, overvoltage, overload, power limiting, ILIM pin short and thermal shutdown conditions. The device is designed to eliminate false reporting by using an internal "de-glitch" circuit for fault conditions without the need for an external circuitry. FLT can be left open or connected to GND when not used.

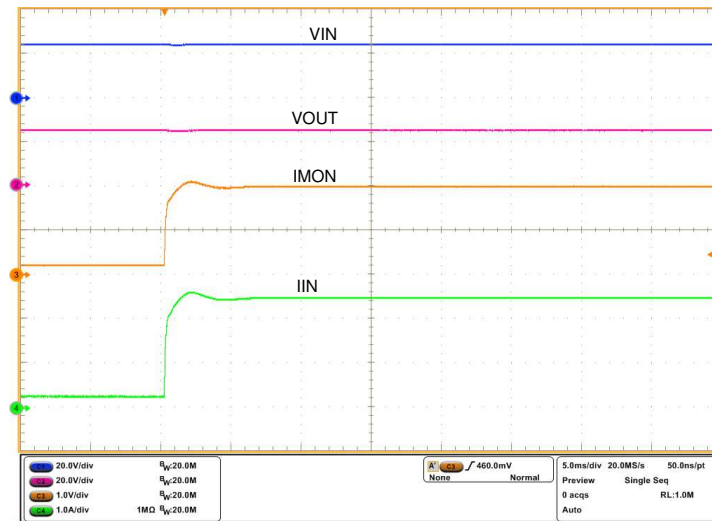
### 9.3.8 Power Good Output (PGOOD)

The devices feature an open drain Power good (PGOOD) indicator output. PGOOD can be used for enable-disable control of the downstream loads like DC-DC converters. PGOOD goes high when the internal FET's gate is enhanced. It goes low when the internal FET turns OFF during a fault event or when SHDN is pulled low. There is a deglitch of 11.5 msec (typical),  $t_{\text{PGOODR}}$  at the rising edge and 10 msec (typical),  $t_{\text{PGOODF}}$  on falling edge. PGOOD is a rated for 60 V and can be pulled to IN or OUT through a resistor.

### 9.3.9 IN, P\_IN, OUT and GND Pins

Connect a minimum of 0.1- $\mu\text{F}$  capacitor across IN and GND. Connect P\_IN and IN together. Do not leave any of the IN and OUT pins un-connected.

### 9.3.10 Thermal Shutdown

The device has a built-in overtemperature shutdown circuitry designed to protect the internal FET, if the junction temperature exceeds  $T_{(\text{TSD})}$ , 165°C (typical). After the thermal shutdown event, depending upon the mode of fault response configured as shown in表 1, the device either latches off or commences an auto-retry cycle of 648 msec (typical),  $t_{(\text{TSD\_retry})}$  after  $T_{\text{J}} < [T_{(\text{TSD})} - 11^\circ\text{C}]$ . During the thermal shutdown, the fault pin  $\overline{\text{FLT}}$  pulls low to indicate a fault condition.

### 9.3.11 Low Current Shutdown Control ( $\overline{\text{SHDN}}$ )

The internal and the external FET and hence the load current can be switched off by pulling the  $\overline{\text{SHDN}}$  pin below 0.8-V threshold with a micro-controller GPIO pin or can be controlled remotely with an opto-isolator device. The device quiescent current reduces to 21  $\mu\text{A}$  (typical) in shutdown state. To assert SHDN low, the pull down must have sinking capability of at least 10  $\mu\text{A}$ . To enable the device,  $\overline{\text{SHDN}}$  must be pulled up to at least 2 V. Once the device is enabled, the internal FET turns on with dVdT mode.图 27 and 图 28 illustrate the performance of  $\overline{\text{SHDN}}$  control.

Feature Description (接下页)

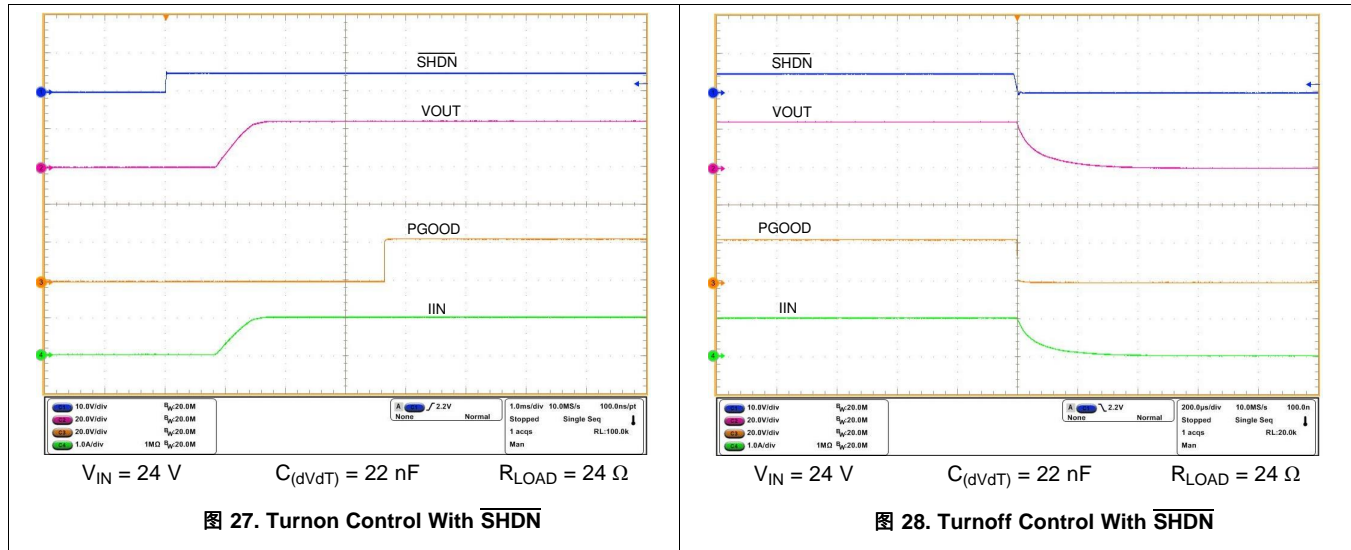

9.4 Device Functional Modes

The TPS1663x devices respond differently to overload with MODE pin configurations. The operational differences are explained in 表 1.

表 1. Device Operational Differences Under Different MODE Configurations

MODE Pin Configuration	Power Limiting, Over Current fault and Thermal Shutdown Operation
Open	Active Current limiting for a maximum duration of $t_{\text{CL\_PLIM(dly)}}$ . There after Latches OFF. Latch reset by toggling $\overline{\text{SHDN}}$ or UVLO low to high or power cycling IN
Shorted to GND	Active Current limiting for a maximum duration of $t_{\text{CL\_PLIM(dly)}}$ . There after auto-retries after a delay of $t_{\text{(TSD\_retry)}}$ .



## 10 Application and Implementation

### 注

Information in the following applications sections is not part of the TI component specification, and TI does not warrant its accuracy or completeness. TI's customers are responsible for determining suitability of components for their purposes. Customers should validate and test their design implementation to confirm system functionality.

### 10.1 Application Information

The TPS1663x is a 60-V eFuse, typically used for Hot-Swap and Power rail protection applications. It operates from 4.5 V to 60 V with programmable current limit, overvoltage, undervoltage protections. The device aids in controlling in-rush current and provides output power limiting for systems such as PLCs, Telecom Radios, Industrial Printers. The device also provides robust protection for multiple faults on the system rail.

The [Detailed Design Procedure](#) section can be used to select component values for the device. Additionally, a spreadsheet design tool [TPS1663 Design Calculator](#) is available in the web product folder.

### 10.2 Typical Application



图 29. 20 V - 50 V, 1-A eFuse Protection Circuit for Telecom Radios

#### 10.2.1 Design Requirements

表 2 shows the Design Requirements for TPS16630.

表 2. Design Requirements

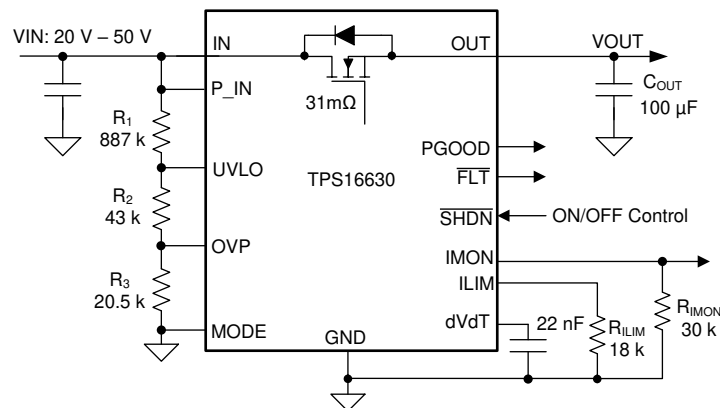
DESIGN PARAMETER		EXAMPLE VALUE
$V_{(IN)}$	Input voltage range	20 V - 50 V
$V_{(UV)}$	Undervoltage lockout set point	18 V
$V_{(OV)}$	Overvoltage cutoff set point	55 V
$I_{(LIM)}$	Overload Current limit	1 A
$C_{OUT}$	Output capacitor	100 μF
$I_{(INRUSH)}$	Inrush Current limit	300 mA

#### 10.2.2 Detailed Design Procedure

##### 10.2.2.1 Programming the Current-Limit Threshold $R_{(ILIM)}$ Selection

The  $R_{(ILIM)}$  resistor at the ILIM pin sets the overload current limit, this can be set using 公式 7.

$$R_{(ILIM)} = \frac{18}{I_{OL}} = 18k\Omega$$

where

- $I_{LIM} = 1 \text{ A}$  (7)

Choose the closest standard 1% resistor value :  $R_{(LIM)} = 18 \text{ k}\Omega$

### 10.2.2.2 Undervoltage Lockout and Overvoltage Set Point

The undervoltage lockout (UVLO) and overvoltage trip point are adjusted using an external voltage divider network of  $R_1$ ,  $R_2$  and  $R_3$  connected between IN, UVLO, OVP and GND pins of the device. The values required for setting the undervoltage and overvoltage are calculated by solving 公式 8 and 公式 9.

$$V_{(OVPR)} = \frac{R_3}{R_1 + R_2 + R_3} \times V_{(OV)} \tag{8}$$

$$V_{(UVLOR)} = \frac{R_2 + R_3}{R_1 + R_2 + R_3} \times V_{(UV)} \tag{9}$$

For minimizing the input current drawn from the power supply  $\{I_{(R123)} = V_{(IN)} / (R_1 + R_2 + R_3)\}$ , it is recommended to use higher value resistance for  $R_1$ ,  $R_2$  and  $R_3$ .

However, the leakage current due to external active components connected at resistor string can add error to these calculations. So, the resistor string current,  $I_{(R123)}$  must be chosen to be 20x greater than the leakage current of UVLO and OVP pins.

From the device electrical specifications,  $V_{(OVPR)} = 1.2 \text{ V}$  and  $V_{(UVLOR)} = 1.2 \text{ V}$ . From the design requirements,  $V_{(OV)}$  is 55 V and  $V_{(UV)}$  is 18 V. To solve the equation, first choose the value of  $R_3 = 20.5 \text{ k}\Omega$  and use 公式 8 to solve for  $(R_1 + R_2) = 930 \text{ k}\Omega$ . Use 公式 9 and value of  $(R_1 + R_2)$  to solve for  $R_2 = 43 \text{ k}\Omega$  and finally  $R_1 = 887 \text{ k}\Omega$ .

Choose the closest standard 1% resistor values:  $R_1 = 887 \text{ k}\Omega$ ,  $R_2 = 43 \text{ k}\Omega$ , and  $R_3 = 20.5 \text{ k}\Omega$ .

### 10.2.2.3 Setting Output Voltage Ramp Time ( $t_{dVdT}$ )

Use 公式 1 and 公式 2 to calculate required  $C_{(dVdT)}$  for achieving an inrush current of 300 mA.  $C_{(dVdT)} = 22 \text{ nF}$ . 图 30 and 图 31 illustrates the inrush current limiting performance during 50 V hot-plug in condition.

#### 10.2.2.3.1 Support Component Selections $R_{PGOOD}$ and $C_{(IN)}$

The  $R_{PGOOD}$  serves as pull-up for the open-drain output. The current sink by this pin must not exceed 10 mA (see the *Absolute Maximum Ratings* table). Typical resistance value in the range of 10 kΩ to 100 kΩ is recommended for  $R_{PGOOD}$ . 图 33 and 图 35 illustrate the power up and power down performance of the system respectively. The  $C_{IN}$  is a local bypass capacitor to suppress noise at the input. A minimum of 0.1 μF is recommended for  $C_{(IN)}$ .

## 10.2.3 Application Curves

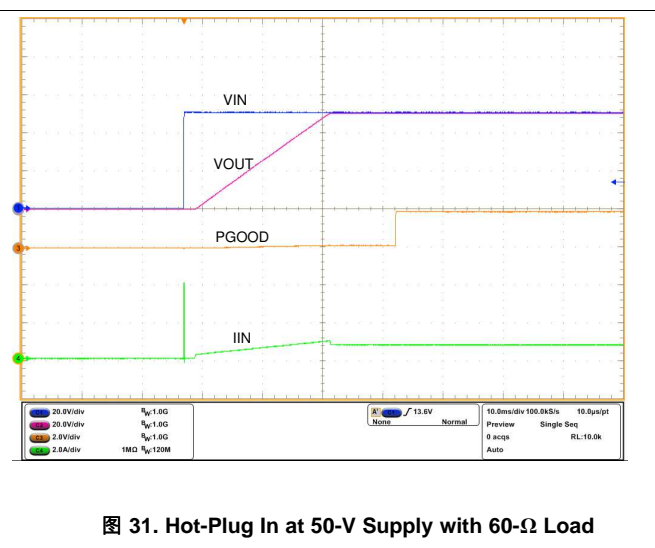
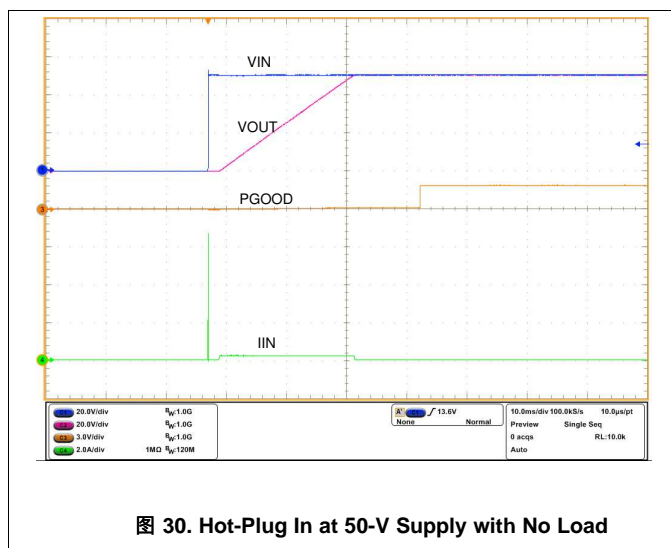



图 32. Overload Performance During Load Step from 140 Ω to 40 Ω



图 33. Coming Out of Overload with Load Step from 40 Ω to 140 Ω

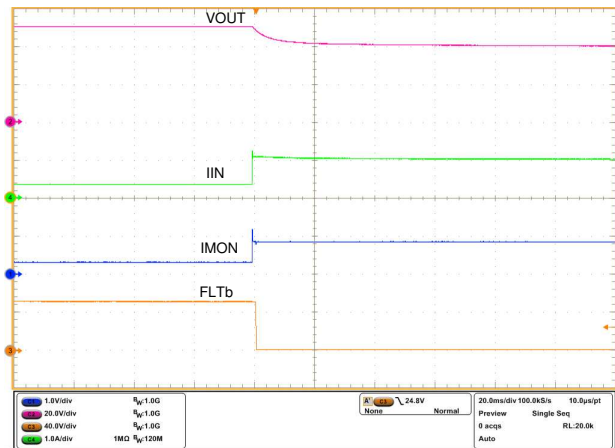

图 34. Output Hot-short Performance with 50-V Input Supply

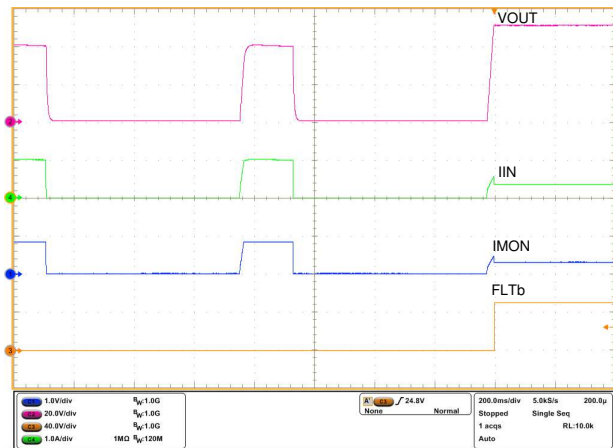

图 35. Turn ON using SHDN Control

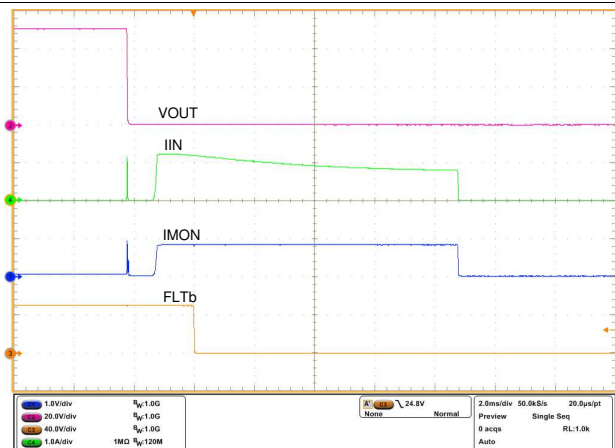

图 36. Turn OFF using SHDN Control

## 10.3 System Examples

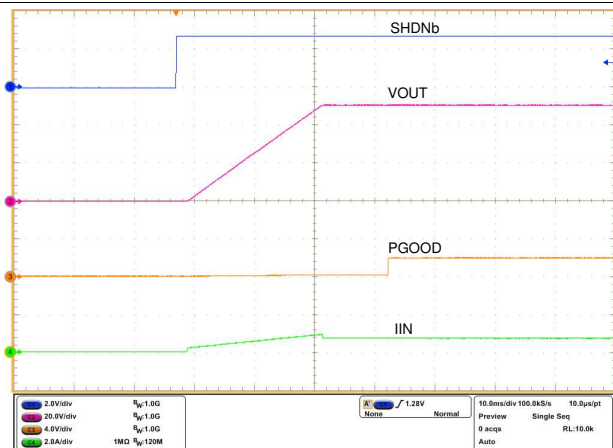
### 10.3.1 Simple 24-V Power Supply Path Protection

With the TPS1663x, a simple 24-V power supply path protection can be realized using a minimum of three external components as shown in the schematic diagram in [图 37](#). The external components required are: a  $R_{(ILIM)}$  resistor to program the current limit,  $C_{(IN)}$  and  $C_{(OUT)}$  capacitors.

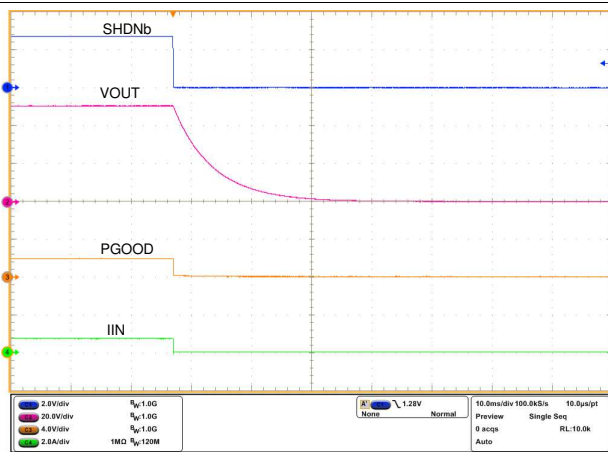
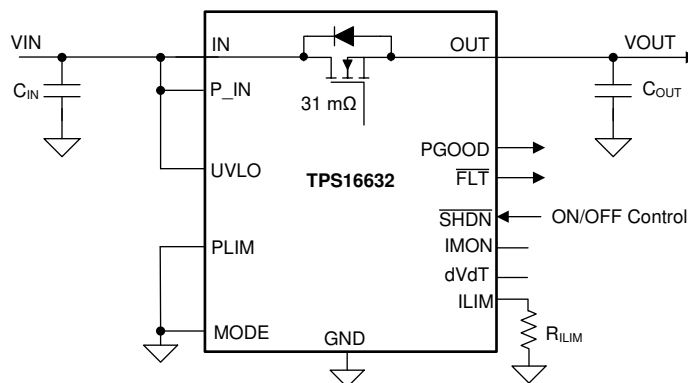

**图 37. TPS16630 Configured for a Simple Power Supply Path Protection**

Protection features with this configuration include:

- 39 V (maximum) overvoltage clamp output
- Inrush current control with 24V/500  $\mu$ s output voltage slew rate
- Accurate current limiting with Auto-Retry

## 11 Power Supply Recommendations

The TPS1663x eFuse is designed for the supply voltage range of  $4.5 \text{ V} \leq V_{IN} \leq 60 \text{ V}$ . If the input supply is located more than a few inches from the device, an input ceramic bypass capacitor higher than 0.1  $\mu$ F is recommended. Power supply must be rated higher than the current limit set to avoid voltage droops during overcurrent and short circuit conditions.

### 11.1 Transient Protection

In case of short circuit and overload current limit, when the device interrupts current flow, input inductance generates a positive voltage spike on the input and output inductance generates a negative voltage spike on the output. The peak amplitude of voltage spikes (transients) depends on the value of inductance in series to the input or output of the device. These transients can exceed the [Absolute Maximum Ratings](#) of the device if steps are not taken to address the issue.

Typical methods for addressing transients include:

- Minimizing lead length and inductance into and out of the device
- Using large PCB GND plane
- Use of a Schottky diode across the output and GND to absorb negative spikes
- A low value ceramic capacitor ( $C_{(IN)}$  to approximately 0.1  $\mu$ F) to absorb the energy and dampen the transients.

The approximate value of input capacitance can be estimated with [公式 10](#).

$$V_{\text{spike(Absolute)}} = V_{(IN)} + I_{(Load)} \times \sqrt{\frac{L_{(IN)}}{C_{(IN)}}}$$

where

- $V_{(IN)}$  is the nominal supply voltage

## Transient Protection (接下页)

- $I_{(LOAD)}$  is the load current
- $L_{(IN)}$  equals the effective inductance seen looking into the source
- $C_{(IN)}$  is the capacitance present at the input

(10)

Some applications may require additional Transient Voltage Suppressor (TVS) to prevent transients from exceeding the *Absolute Maximum Ratings* of the device. These transients can occur during positive and negative surge tests on the supply lines. In such applications it is recommended to place at least 1  $\mu\text{F}$  of input capacitor.

The circuit implementation with optional protection components (a ceramic capacitor, TVS and schottky diode) is shown in 图 38

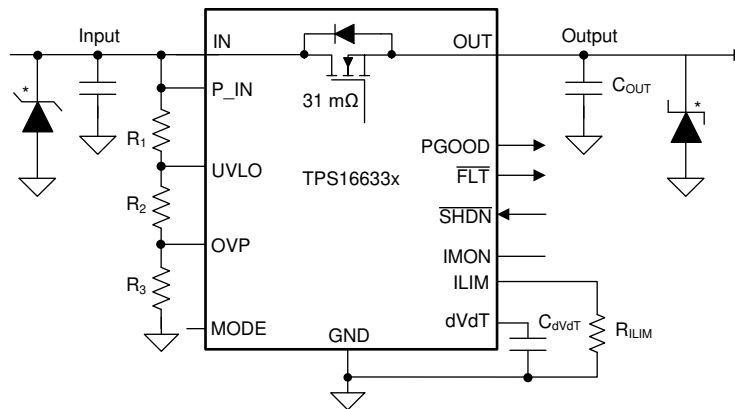

\* Optional components needed for suppression of transients

图 38. Circuit Implementation with Optional Protection Components for TPS1663x

## 12 Layout

### 12.1 Layout Guidelines

- For all the applications, a 0.1  $\mu\text{F}$  or higher value ceramic decoupling capacitor is recommended between IN terminal and GND.
- High current carrying power path connections must be as short as possible and must be sized to carry at least twice the full-load current. See [Figure 39](#) and [Figure 40](#) for a typical PCB layout example.
- Locate all the TPS1663x family support components  $R_{(ILIM)}$ ,  $R_{(PLIM)}$ ,  $C_{(dVdT)}$ ,  $R_{(IMON)}$ , UVLO, OVP resistors close to their connection pin. Connect the other end of the component to the GND with shortest trace length.
- The trace routing for the  $R_{(ILIM)}$ ,  $R_{(PLIM)}$  component to the device must be as short as possible to reduce parasitic effects on the current limit and power limit accuracy. These traces must not have any coupling to switching signals on the board.
- Protection devices such as TVS, snubbers, capacitors, or diodes must be placed physically close to the device they are intended to protect, and routed with short traces to reduce inductance. For example, a protection Schottky diode is recommended to address negative transients due to switching of inductive loads, and it must be physically close to the OUT and GND pins.
- Thermal Considerations: When properly mounted, the PowerPAD package provides significantly greater cooling ability. To operate at rated power, the PowerPAD must be soldered directly to the board GND plane directly under the device. Other planes, such as the bottom side of the circuit board can be used to increase heat sinking in higher current applications.

## 12.2 Layout Example

- Top Layer
- Bottom layer GND plane
- Top Layer GND Plane
- Via to Bottom Layer



图 39. PCB Layout Example with QFN Package with a 2 Layer PCB

Layout Example (接下页)

- Top Layer
- ▨ Bottom layer GND plane
- Top Layer GND Plane
- Via to Bottom Layer

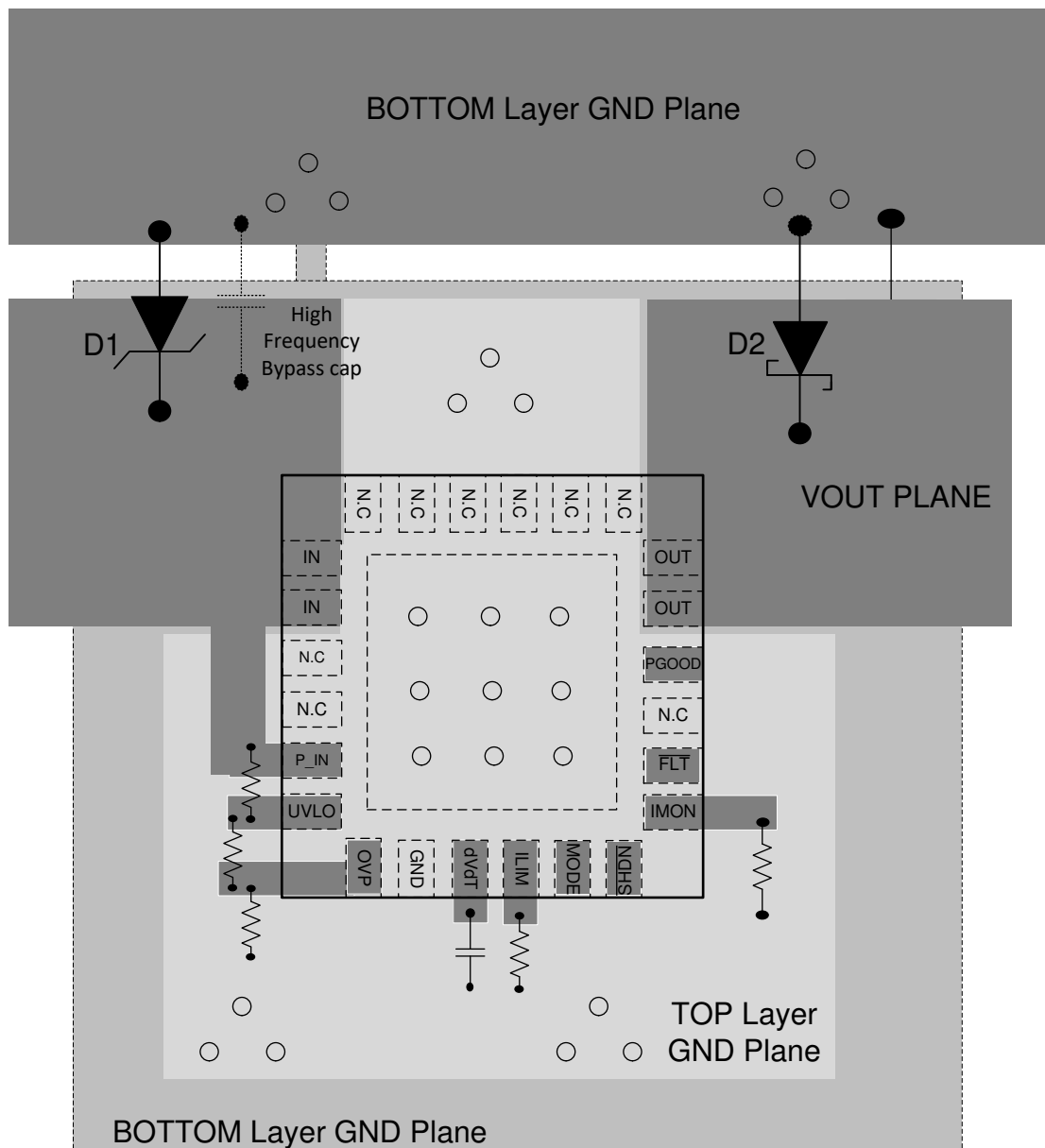

图 40. Typical PCB Layout Example with HTSSOP Package with a 2 Layer PCB



## 13 器件和文档支持

### 13.1 文档支持

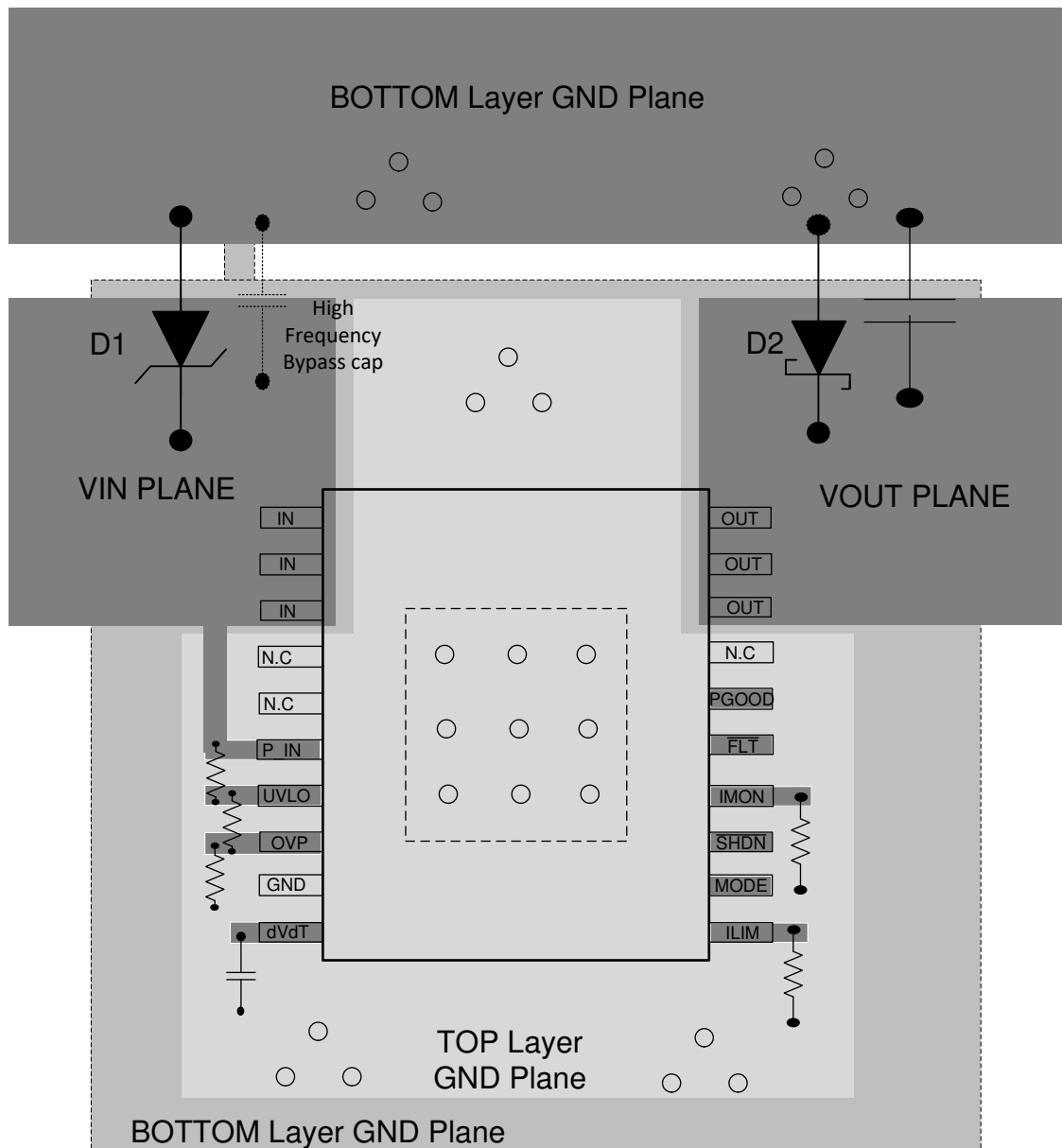
#### 13.1.1 相关文档

- [TPS1663 设计计算器](#)

### 13.2 接收文档更新通知

要接收文档更新通知，请导航至 [ti.com.cn](http://ti.com.cn) 上的器件产品文件夹。单击右上角的通知我进行注册，即可每周接收产品信息更改摘要。有关更改的详细信息，请查看任何已修订文档中包含的修订历史记录。

### 13.3 社区资源

TI E2E™ [support forums](#) are an engineer's go-to source for fast, verified answers and design help — straight from the experts. Search existing answers or ask your own question to get the quick design help you need.

Linked content is provided "AS IS" by the respective contributors. They do not constitute TI specifications and do not necessarily reflect TI's views; see TI's [Terms of Use](#).

### 13.4 商标

E2E is a trademark of Texas Instruments.

### 13.5 静电放电警告



ESD 可能会损坏该集成电路。德州仪器 (TI) 建议通过适当的预防措施处理所有集成电路。如果不遵守正确的处理措施和安装程序，可能会损坏集成电路。

ESD 的损坏小至导致微小的性能降级，大至整个器件故障。精密的集成电路可能更容易受到损坏，这是因为非常细微的参数更改都可能会导致器件与其发布的规格不相符。

### 13.6 Glossary

[SLYZ022](#) — *TI Glossary*.

This glossary lists and explains terms, acronyms, and definitions.

## 14 机械、封装和可订购信息

以下页面包含机械、封装和可订购信息。这些信息是指定器件的最新可用数据。数据如有变更，恕不另行通知，且不会对此文档进行修订。如需获取此数据表的浏览器版本，请查阅左侧的导航栏。

## 14.1 Package Option Addendum

### 14.1.1 Packaging Information

Orderable Device	Status <sup>(1)</sup>	Package Type	Package Drawing	Pins	Package Qty	Eco Plan <sup>(2)</sup>	Lead/Ball Finish <sup>(3)</sup>	MSL Peak Temp <sup>(4)</sup>	Op Temp (°C)	Device Marking <sup>(5)(6)</sup>
PTPS16630PWPR	ACTIVE	HTSSOP	PWP	20	2000	TBD	Call TI	Call TI	-40 to 125	
TPS16630PWPR	ACTIVE	HTSSOP	PWP	20	2000	Green (RoHS& no Sb/Br)	CU NIPDAU	Level-2-260C-1 YEAR	-40 to 125	TPS16630
TPS16630PWPT	ACTIVE	HTSSOP	PWP	20	250	Green (RoHS& no Sb/Br)	CU NIPDAU	Level-2-260C-1 YEAR	-40 to 125	TPS16630

(1) The marketing status values are defined as follows:

**ACTIVE:** Product device recommended for new designs.

**LIFEBUY:** TI has announced that the device will be discontinued, and a lifetime-buy period is in effect.

**NRND:** Not recommended for new designs. Device is in production to support existing customers, but TI does not recommend using this part in a new design.

**PRE\_PROD** Unannounced device, not in production, not available for mass market, nor on the web, samples not available.

**PREVIEW:** Device has been announced but is not in production. Samples may or may not be available.

**OBSOLETE:** TI has discontinued the production of the device.

(2) Eco Plan - The planned eco-friendly classification: Pb-Free (RoHS), Pb-Free (RoHS Exempt), or Green (RoHS & no Sb/Br) - please check <http://www.ti.com/productcontent> for the latest availability information and additional product content details.

**TBD:** The Pb-Free/Green conversion plan has not been defined.

**Pb-Free (RoHS):** TI's terms "Lead-Free" or "Pb-Free" mean semiconductor products that are compatible with the current RoHS requirements for all 6 substances, including the requirement that lead not exceed 0.1% by weight in homogeneous materials. Where designed to be soldered at high temperatures, TI Pb-Free products are suitable for use in specified lead-free processes.

**Pb-Free (RoHS Exempt):** This component has a RoHS exemption for either 1) lead-based flip-chip solder bumps used between the die and package, or 2) lead-based die adhesive used between the die and leadframe. The component is otherwise considered Pb-Free (RoHS compatible) as defined above.

**Green (RoHS & no Sb/Br):** TI defines "Green" to mean Pb-Free (RoHS compatible), and free of Bromine (Br) and Antimony (Sb) based flame retardants (Br or Sb do not exceed 0.1% by weight in homogeneous material)

(3) Lead/Ball Finish - Orderable Devices may have multiple material finish options. Finish options are separated by a vertical ruled line. Lead/Ball Finish values may wrap to two lines if the finish value exceeds the maximum column width.

(4) MSL, Peak Temp. -- The Moisture Sensitivity Level rating according to the JEDEC industry standard classifications, and peak solder temperature.

(5) There may be additional marking, which relates to the logo, the lot trace code information, or the environmental category on the device

(6) Multiple Device markings will be inside parentheses. Only one Device Marking contained in parentheses and separated by a "-" will appear on a device. If a line is indented then it is a continuation of the previous line and the two combined represent the entire Device Marking for that device.

**Important Information and Disclaimer:** The information provided on this page represents TI's knowledge and belief as of the date that it is provided. TI bases its knowledge and belief on information provided by third parties, and makes no representation or warranty as to the accuracy of such information. Efforts are underway to better integrate information from third parties. TI has taken and continues to take reasonable steps to provide representative and accurate information but may not have conducted destructive testing or chemical analysis on incoming materials and chemicals. TI and TI suppliers consider certain information to be proprietary, and thus CAS numbers and other limited information may not be available for release.

In no event shall TI's liability arising out of such information exceed the total purchase price of the TI part(s) at issue in this document sold by TI to Customer on an annual basis.

**Package Option Addendum (接下页)**

Orderable Device	Status <sup>(1)</sup>	Package Type	Package Drawing	Pins	Package Qty	Eco Plan <sup>(2)</sup>	Lead/Ball Finish <sup>(3)</sup>	MSL Peak Temp <sup>(4)</sup>	Op Temp (°C)	Device Marking <sup>(5)(6)</sup>
TPS16630RGER	ACTIVE	VQFN	RGE	24	3000	Green (RoHS& no Sb/Br)	CU NIPDAU	Level-2-260C-1 YEAR	-40 to 125	TPS16630
TPS16630RGET	ACTIVE	VQFN	RGE	24	250	Green (RoHS& no Sb/Br)	CU NIPDAU	Level-2-260C-1 YEAR	-40 to 125	TPS16630
TPS16632RGER	ACTIVE	VQFN	RGE	24	3000	Green (RoHS& no Sb/Br)	CU NIPDAU	Level-2-260C-1 YEAR	-40 to 125	TPS16632
TPS16632RGET	ACTIVE	VQFN	RGE	24	250	Green (RoHS& no Sb/Br)	CU NIPDAU	Level-2-260C-1 YEAR	-40 to 125	TPS16632

### 14.1.2 Tape and Reel Information

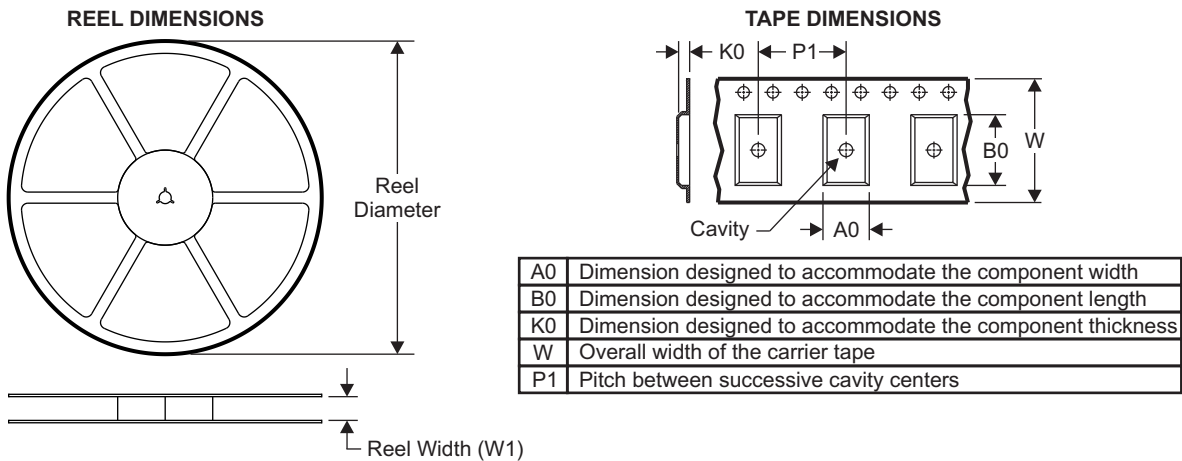

#### QUADRANT ASSIGNMENTS FOR PIN 1 ORIENTATION IN TAPE

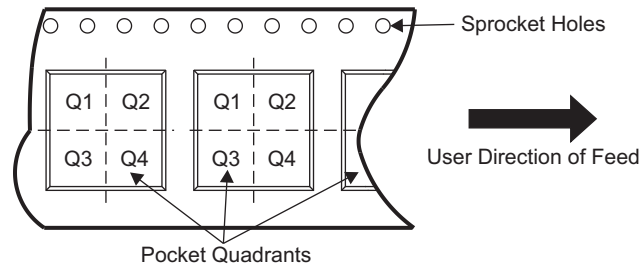

Device	Package Type	Package Drawing	Pins	SPQ	Reel Diameter (mm)	Reel Width W1 (mm)	A0 (mm)	B0 (mm)	K0 (mm)	P1 (mm)	W (mm)	Pin1 Quadrant
TPS16630PWPR	HTSSOP	PWP	20	2000	330.0	16.4	6.95	7.0	1.4	8.0	16.0	Q1
TPS16630PWPT	HTSSOP	PWP	20	250	180.0	16.4	6.95	7.0	1.4	8.0	16.0	Q1
TPS16630RGER	VQFN	RGE	24	3000	330.0	12.4	4.25	4.25	1.15	8.0	12.0	Q2
TPS16630RGET	VQFN	RGE	24	250	180.0	12.4	4.25	4.25	1.15	8.0	12.0	Q2
TPS16632RGER	VQFN	RGE	24	3000	330.0	12.4	4.25	4.25	1.15	8.0	12.0	Q2
TPS16632RGET	VQFN	RGE	24	250	180.0	12.4	4.25	4.25	1.15	8.0	12.0	Q2

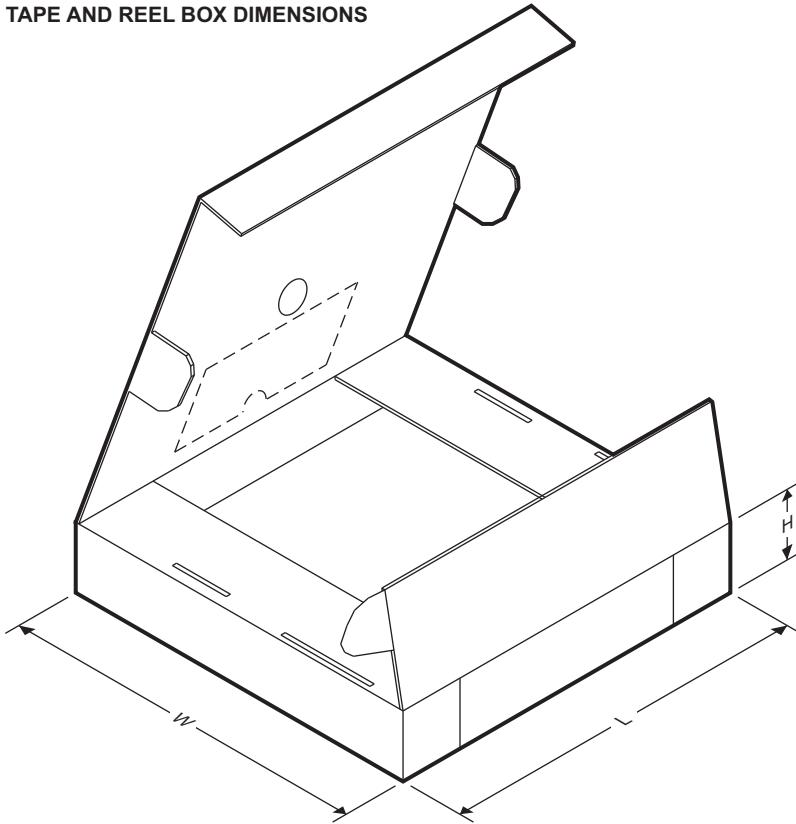
**TAPE AND REEL BOX DIMENSIONS**

Device	Package Type	Package Drawing	Pins	SPQ	Length (mm)	Width (mm)	Height (mm)
TPS16630PWPR	HTSSOP	PWP	20	2000	367.0	367.0	38.0
TPS16630PWPT	HTSSOP	PWP	20	250	210.0	185.0	35.0
TPS16630RGER	VQFN	RGE	24	3000	367.0	367.0	35.0
TPS16630RGET	VQFN	RGE	24	250	210.0	185.0	35.0
TPS16632RGER	VQFN	RGE	24	3000	367.0	367.0	35.0
TPS16632RGET	VQFN	RGE	24	250	210.0	185.0	35.0



# PACKAGE OUTLINE

## PWP0020T

## PowerPAD™ TSSOP - 1.2 mm max height

SMALL OUTLINE PACKAGE

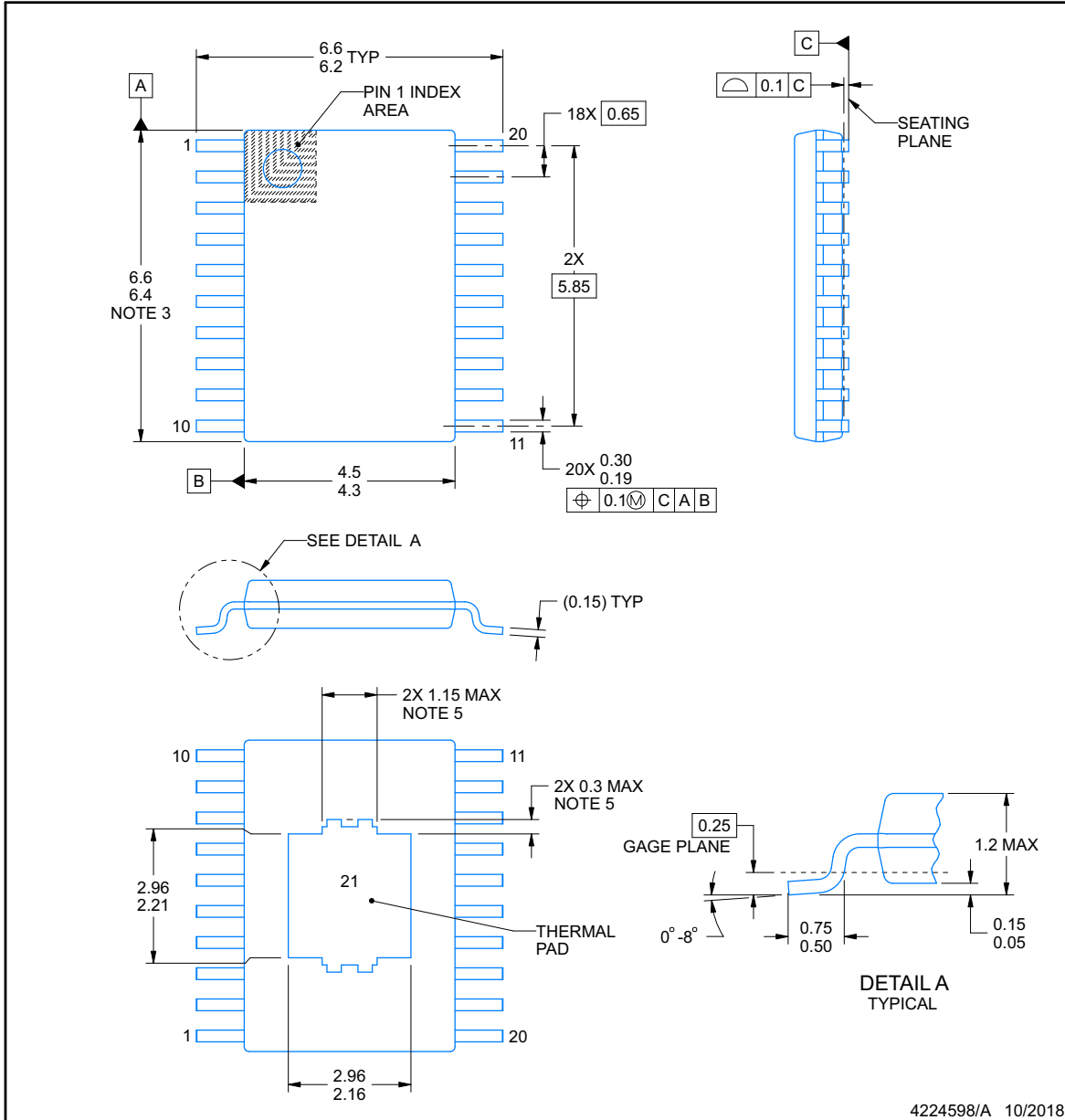

PowerPAD is a trademark of Texas Instruments.

**NOTES:**

1. All linear dimensions are in millimeters. Any dimensions in parenthesis are for reference only. Dimensioning and tolerancing per ASME Y14.5M.
2. This drawing is subject to change without notice.
3. This dimension does not include mold flash, protrusions, or gate burrs. Mold flash, protrusions, or gate burrs shall not exceed 0.15 mm per side.
4. Reference JEDEC registration MO-153.
5. Features may differ or may not be present.

### EXAMPLE BOARD LAYOUT

#### PWP0020T

#### PowerPAD™ TSSOP - 1.2 mm max height

SMALL OUTLINE PACKAGE

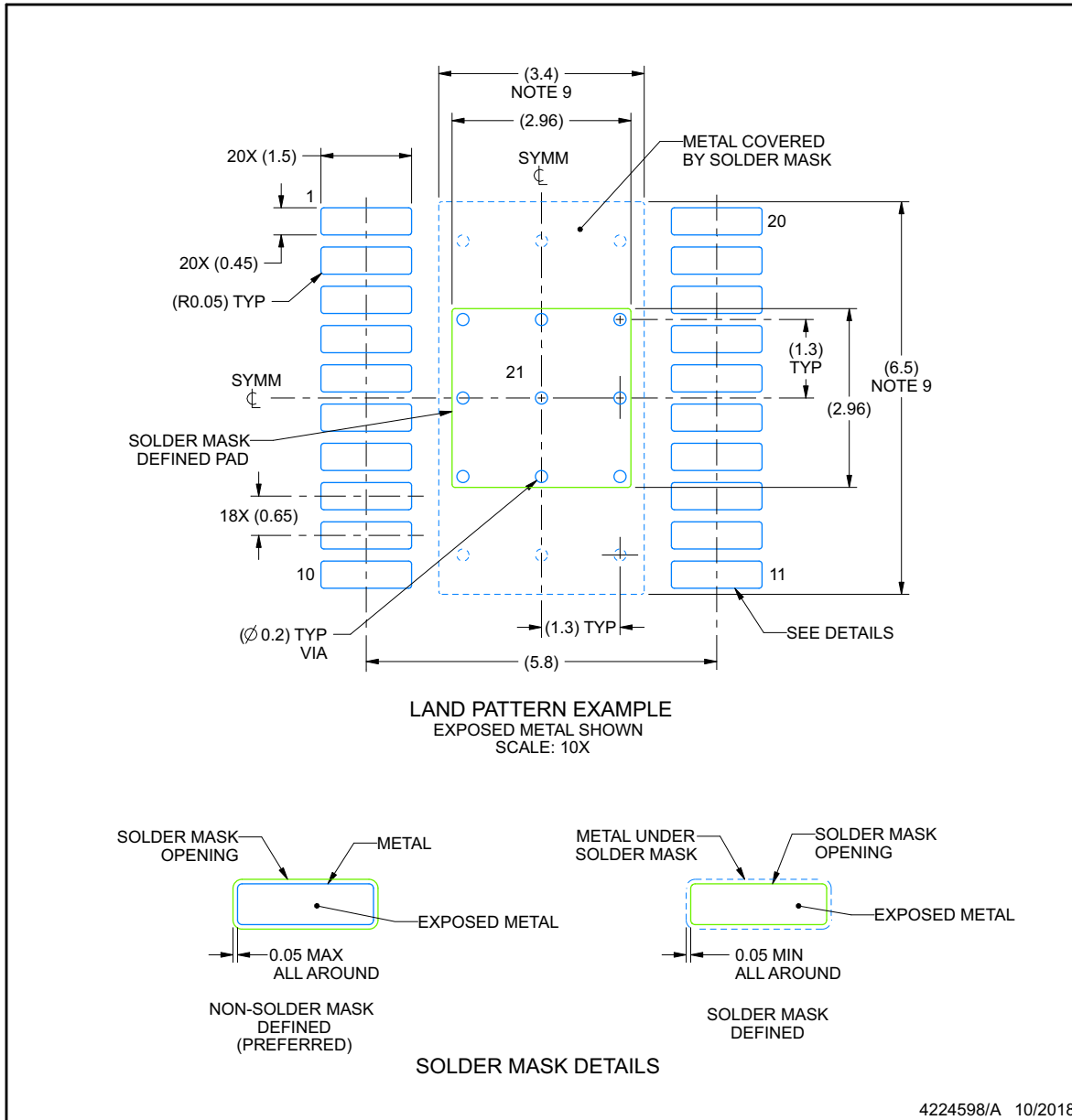

NOTES: (continued)

- 6. Publication IPC-7351 may have alternate designs.
- 7. Solder mask tolerances between and around signal pads can vary based on board fabrication site.
- 8. This package is designed to be soldered to a thermal pad on the board. For more information, see Texas Instruments literature numbers SLMA002 ([www.ti.com/lit/slma002](http://www.ti.com/lit/slma002)) and SLMA004 ([www.ti.com/lit/slma004](http://www.ti.com/lit/slma004)).
- 9. Size of metal pad may vary due to creepage requirement.
- 10. Vias are optional depending on application, refer to device data sheet. It is recommended that vias under paste be filled, plugged or tented.

**EXAMPLE STENCIL DESIGN**

**PWP0020T**

**PowerPAD™ TSSOP - 1.2 mm max height**

SMALL OUTLINE PACKAGE

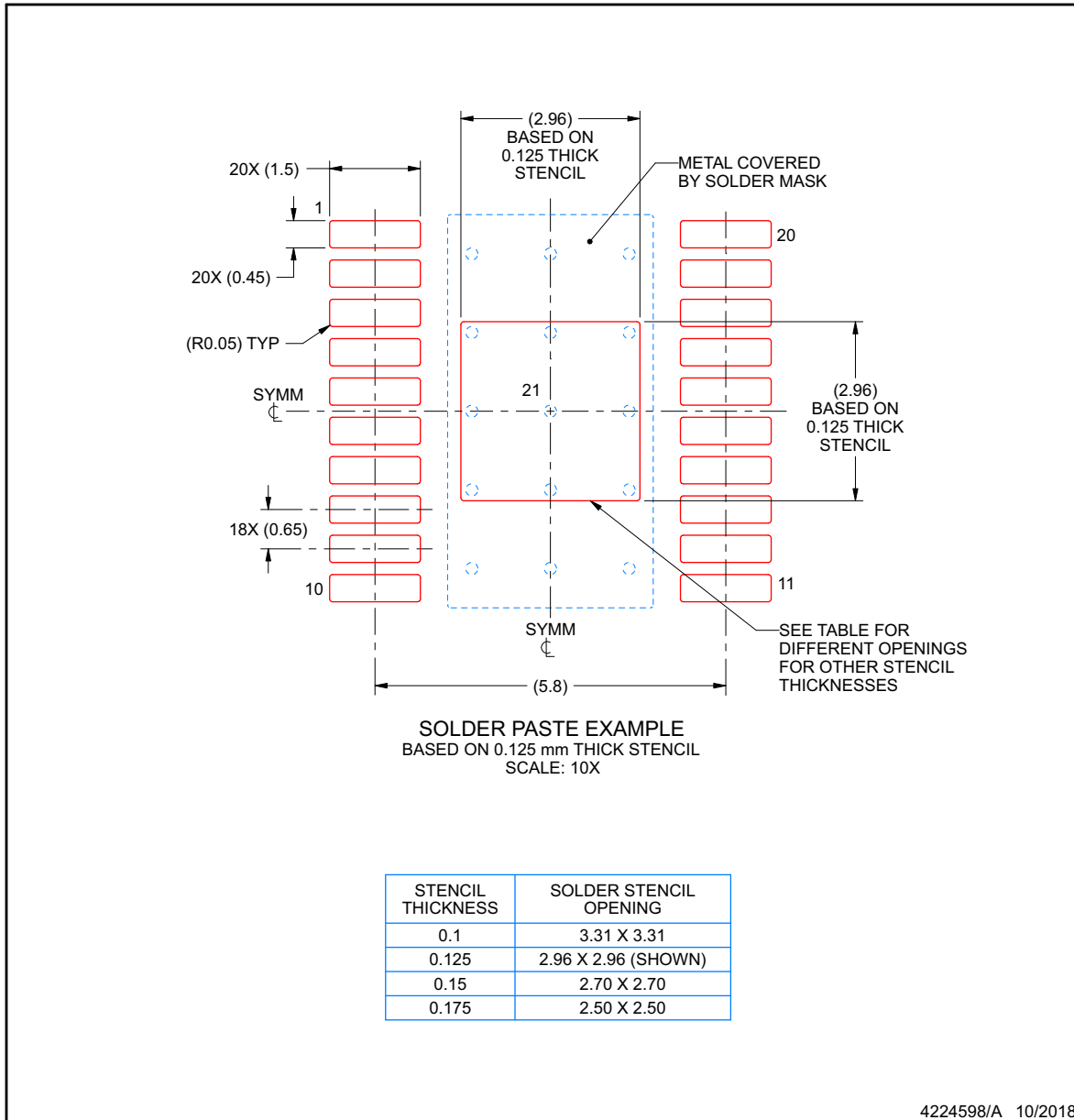

NOTES: (continued)

- 11. Laser cutting apertures with trapezoidal walls and rounded corners may offer better paste release. IPC-7525 may have alternate design recommendations.
- 12. Board assembly site may have different recommendations for stencil design.



**PACKAGE OUTLINE**  
**VQFN - 1 mm max height**

**RGE0024H**

PLASTIC QUAD FLATPACK- NO LEAD

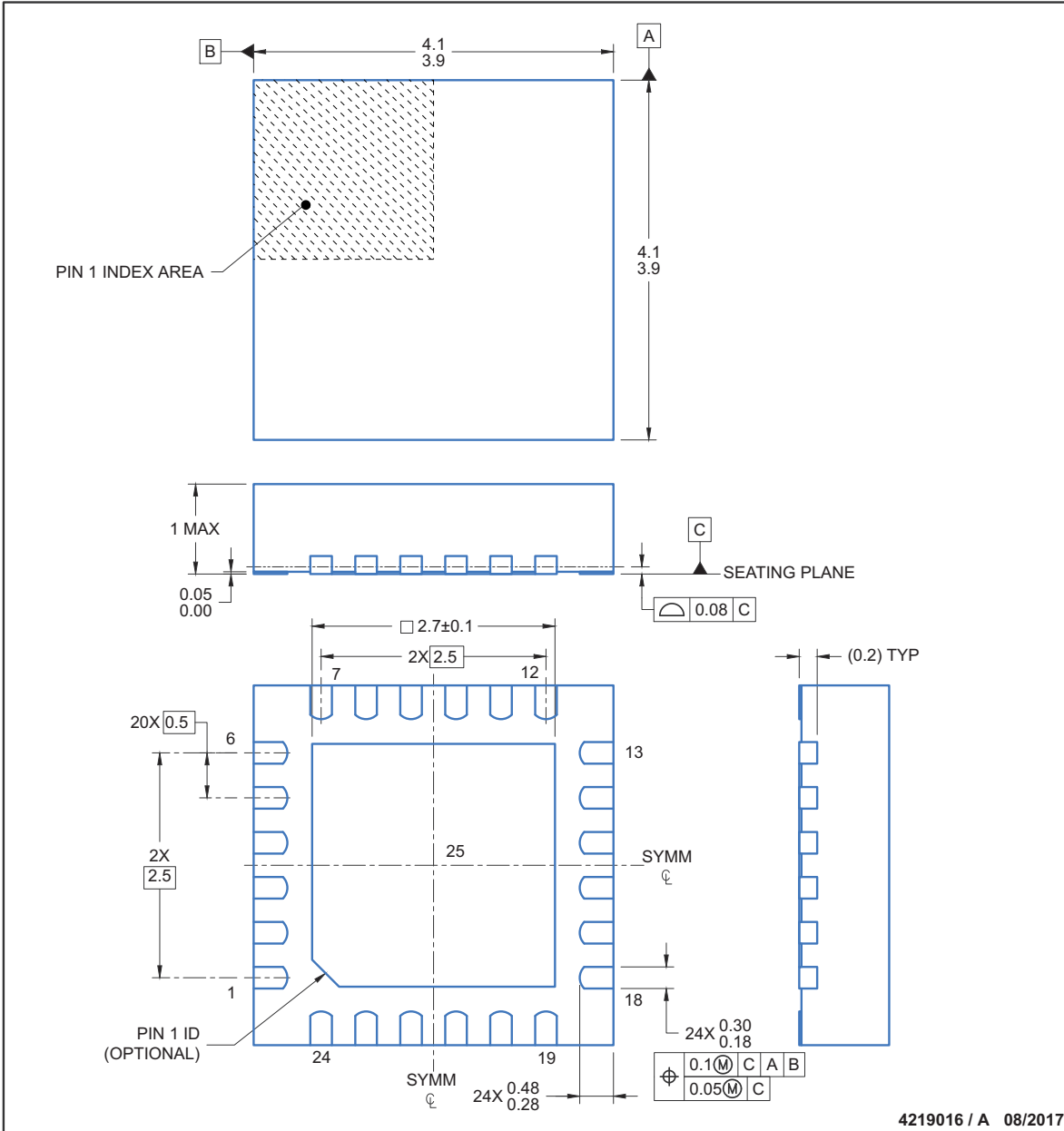

4219016 / A 08/2017

NOTES:

1. All linear dimensions are in millimeters. Any dimensions in parenthesis are for reference only. Dimensioning and tolerancing per ASME Y14.5M.
2. This drawing is subject to change without notice.
3. The package thermal pad must be soldered to the printed circuit board for thermal and mechanical performance.

**EXAMPLE BOARD LAYOUT**  
**VQFN - 1 mm max height**

**RGE0024H**

PLASTIC QUAD FLATPACK- NO LEAD

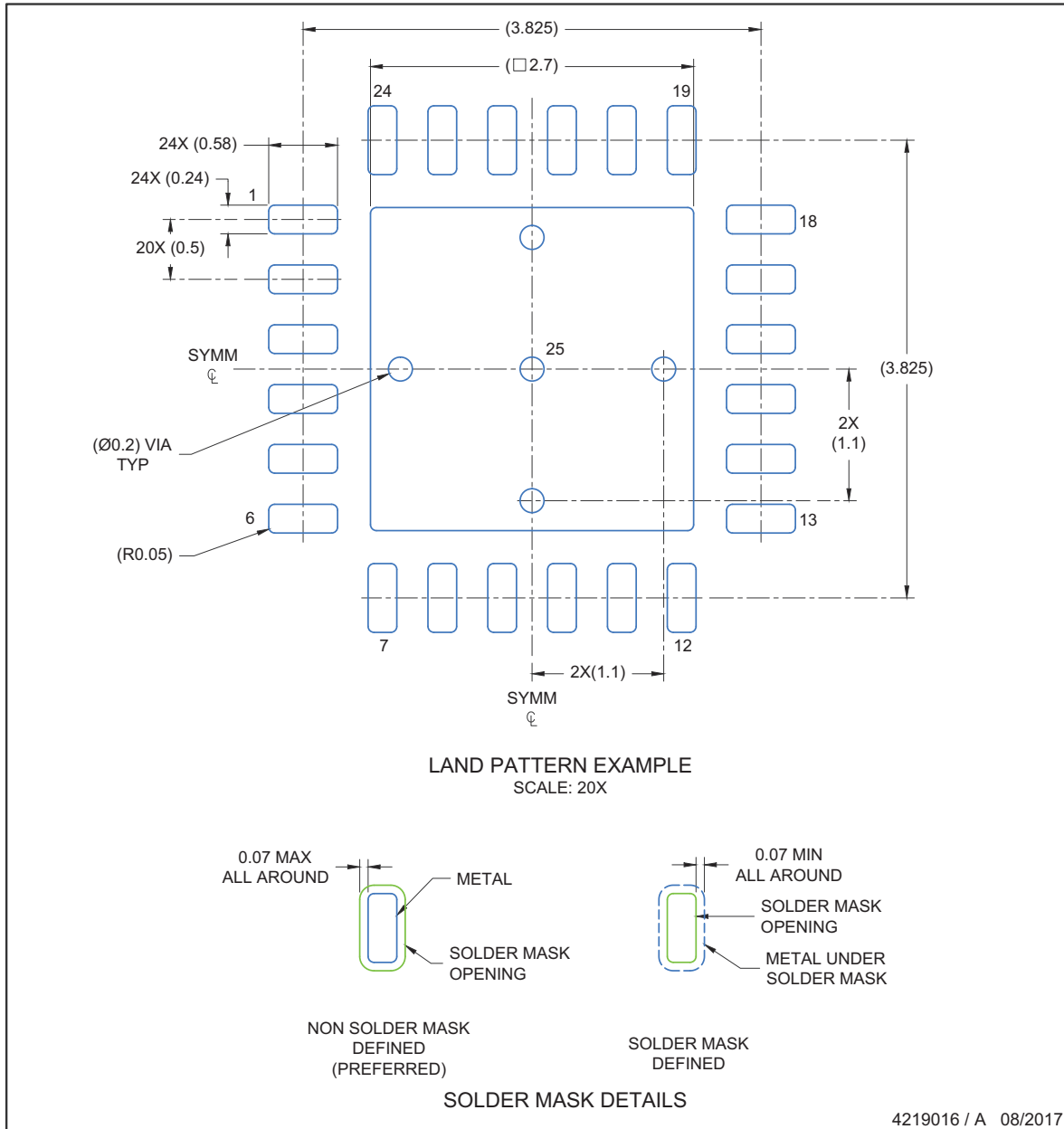

NOTES: (continued)

4. This package is designed to be soldered to a thermal pad on the board. For more information, see Texas Instruments literature number SLUA271 ([www.ti.com/lit/slue271](http://www.ti.com/lit/slue271)).
5. Solder mask tolerances between and around signal pads can vary based on board fabrication site.

**EXAMPLE STENCIL DESIGN**  
**VQFN - 1 mm max height**

**RGE0024H**

PLASTIC QUAD FLATPACK- NO LEAD

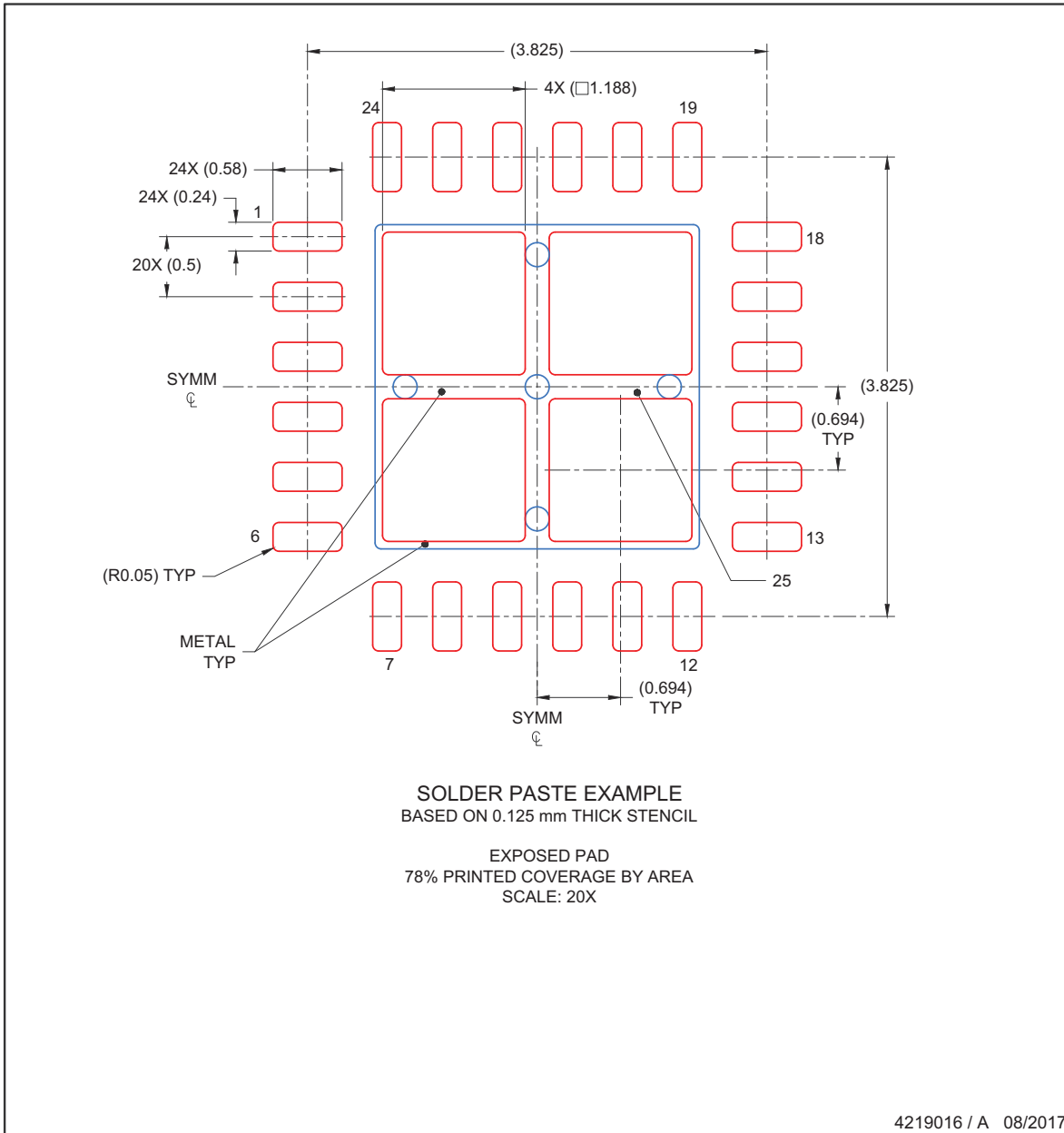

NOTES: (continued)

6. Laser cutting apertures with trapezoidal walls and rounded corners may offer better paste release. IPC-7525 may have alternate design recommendations..

# MECHANICAL DATA

PWP (R-PDSO-G20)

PowerPAD™ PLASTIC SMALL OUTLINE



4073225-4/1 05/11

- NOTES:
- All linear dimensions are in millimeters.
  - This drawing is subject to change without notice.
  - Body dimensions do not include mold flash or protrusions. Mold flash and protrusion shall not exceed 0.15 per side.
  - This package is designed to be soldered to a thermal pad on the board. Refer to Technical Brief, PowerPad Thermally Enhanced Package, Texas Instruments Literature No. SLMA002 for information regarding recommended board layout. This document is available at [www.ti.com](http://www.ti.com) <<http://www.ti.com>>.
  - See the additional figure in the Product Data Sheet for details regarding the exposed thermal pad features and dimensions.
  - Falls within JEDEC MO-153

PowerPAD is a trademark of Texas Instruments.

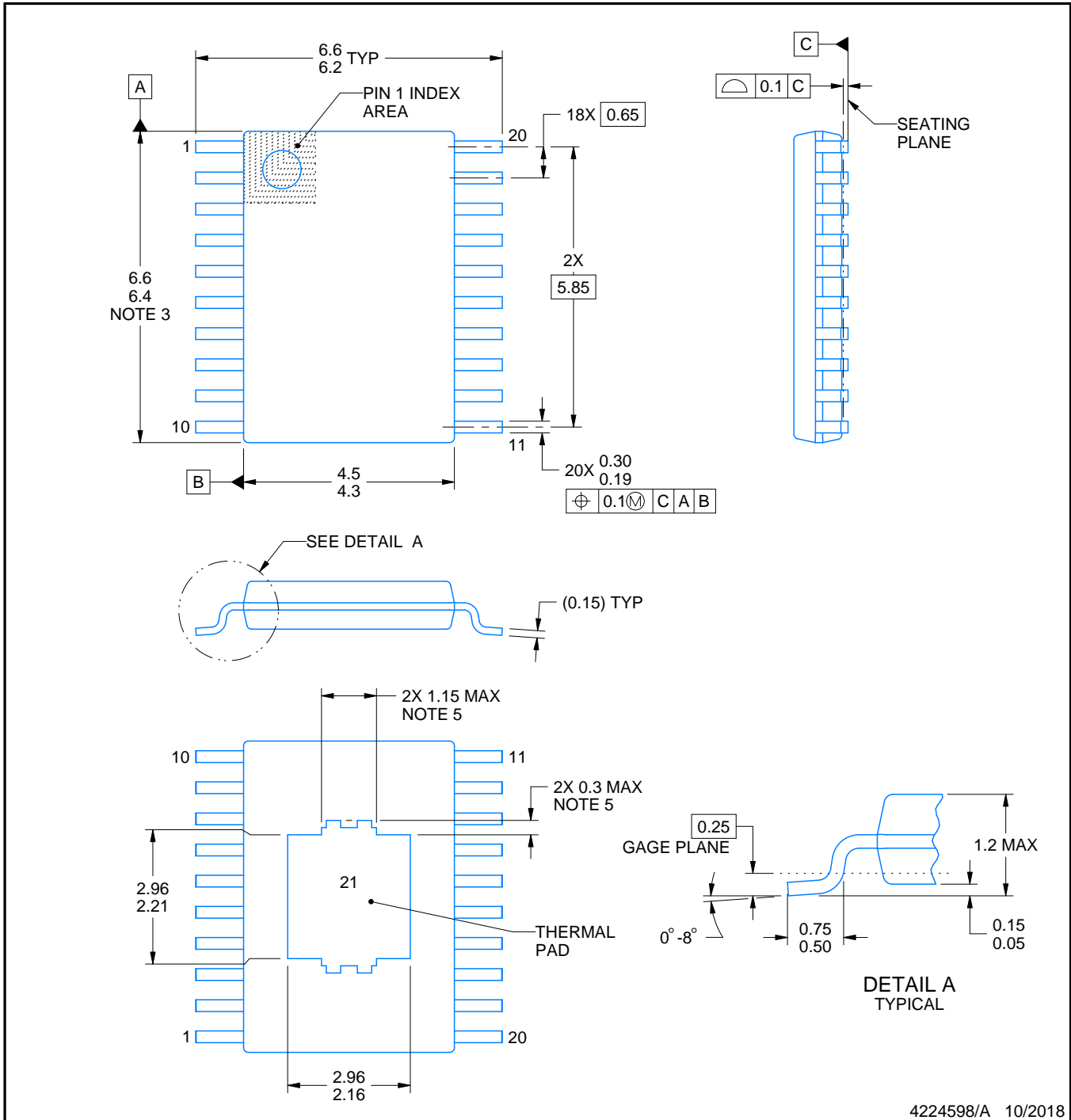
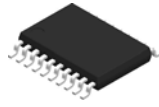

4224598/A 10/2018

PowerPAD is a trademark of Texas Instruments.

NOTES:

1. All linear dimensions are in millimeters. Any dimensions in parenthesis are for reference only. Dimensioning and tolerancing per ASME Y14.5M.
2. This drawing is subject to change without notice.
3. This dimension does not include mold flash, protrusions, or gate burrs. Mold flash, protrusions, or gate burrs shall not exceed 0.15 mm per side.
4. Reference JEDEC registration MO-153.
5. Features may differ or may not be present.

# EXAMPLE BOARD LAYOUT

PWP0020T

PowerPAD™ TSSOP - 1.2 mm max height

SMALL OUTLINE PACKAGE

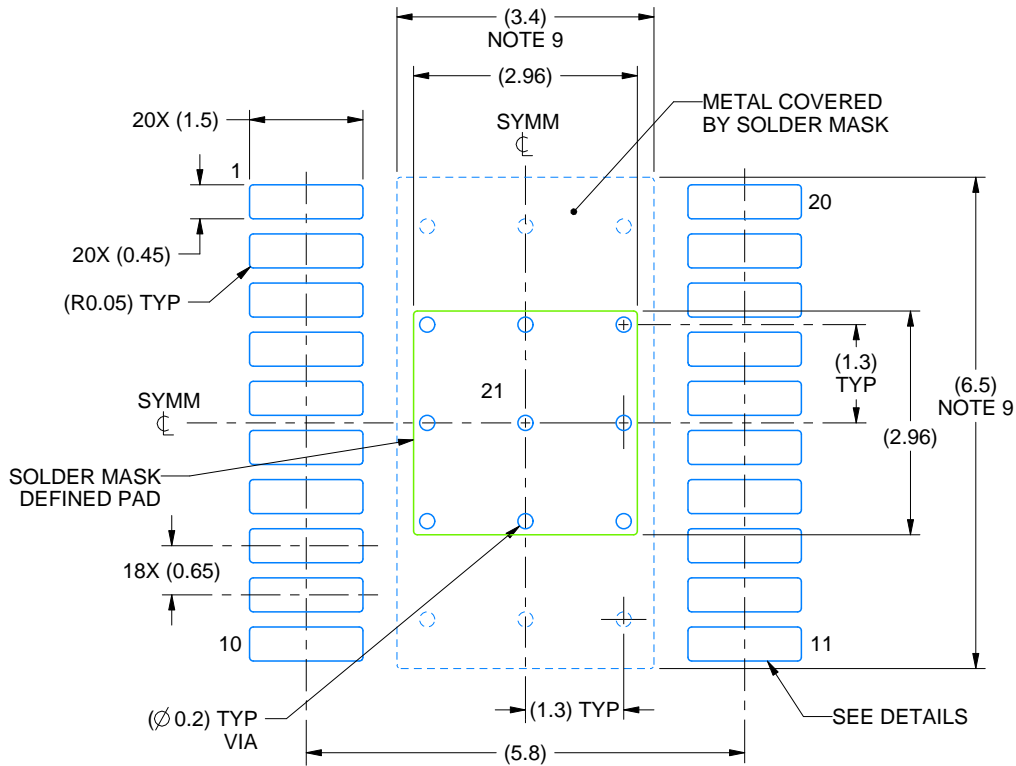

LAND PATTERN EXAMPLE  
EXPOSED METAL SHOWN  
SCALE: 10X

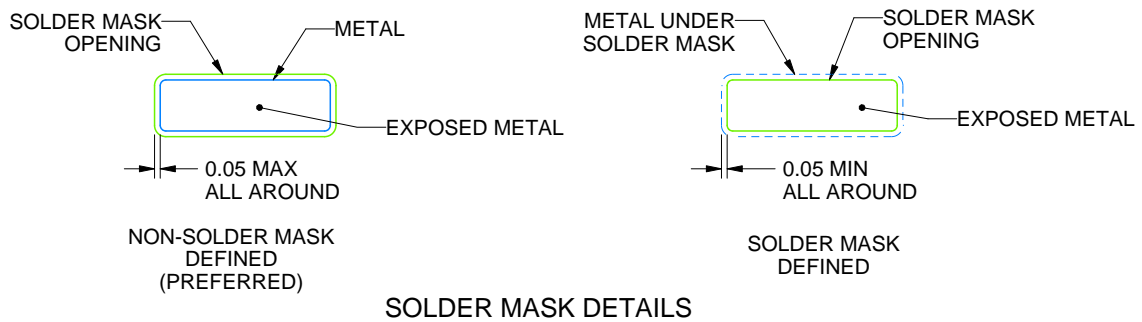

SOLDER MASK DETAILS

4224598/A 10/2018

NOTES: (continued)

6. Publication IPC-7351 may have alternate designs.
7. Solder mask tolerances between and around signal pads can vary based on board fabrication site.
8. This package is designed to be soldered to a thermal pad on the board. For more information, see Texas Instruments literature numbers SLMA002 ([www.ti.com/lit/slma002](http://www.ti.com/lit/slma002)) and SLMA004 ([www.ti.com/lit/slma004](http://www.ti.com/lit/slma004)).
9. Size of metal pad may vary due to creepage requirement.
10. Vias are optional depending on application, refer to device data sheet. It is recommended that vias under paste be filled, plugged or tented.

# EXAMPLE STENCIL DESIGN

PWP0020T

PowerPAD™ TSSOP - 1.2 mm max height

SMALL OUTLINE PACKAGE

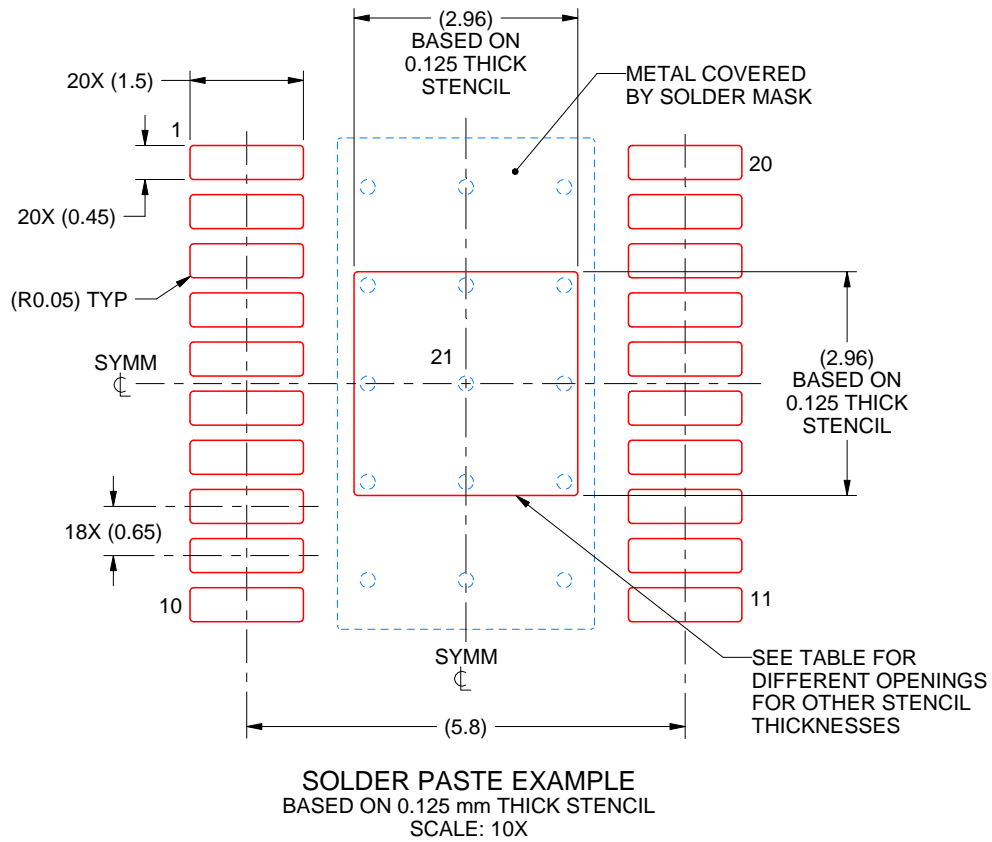

STENCIL THICKNESS	SOLDER STENCIL OPENING
0.1	3.31 X 3.31
0.125	2.96 X 2.96 (SHOWN)
0.15	2.70 X 2.70
0.175	2.50 X 2.50

4224598/A 10/2018

NOTES: (continued)

11. Laser cutting apertures with trapezoidal walls and rounded corners may offer better paste release. IPC-7525 may have alternate design recommendations.
12. Board assembly site may have different recommendations for stencil design.

**RGE 24**

**GENERIC PACKAGE VIEW**

**VQFN - 1 mm max height**

PLASTIC QUAD FLATPACK - NO LEAD



Images above are just a representation of the package family, actual package may vary.  
Refer to the product data sheet for package details.

4204104/H



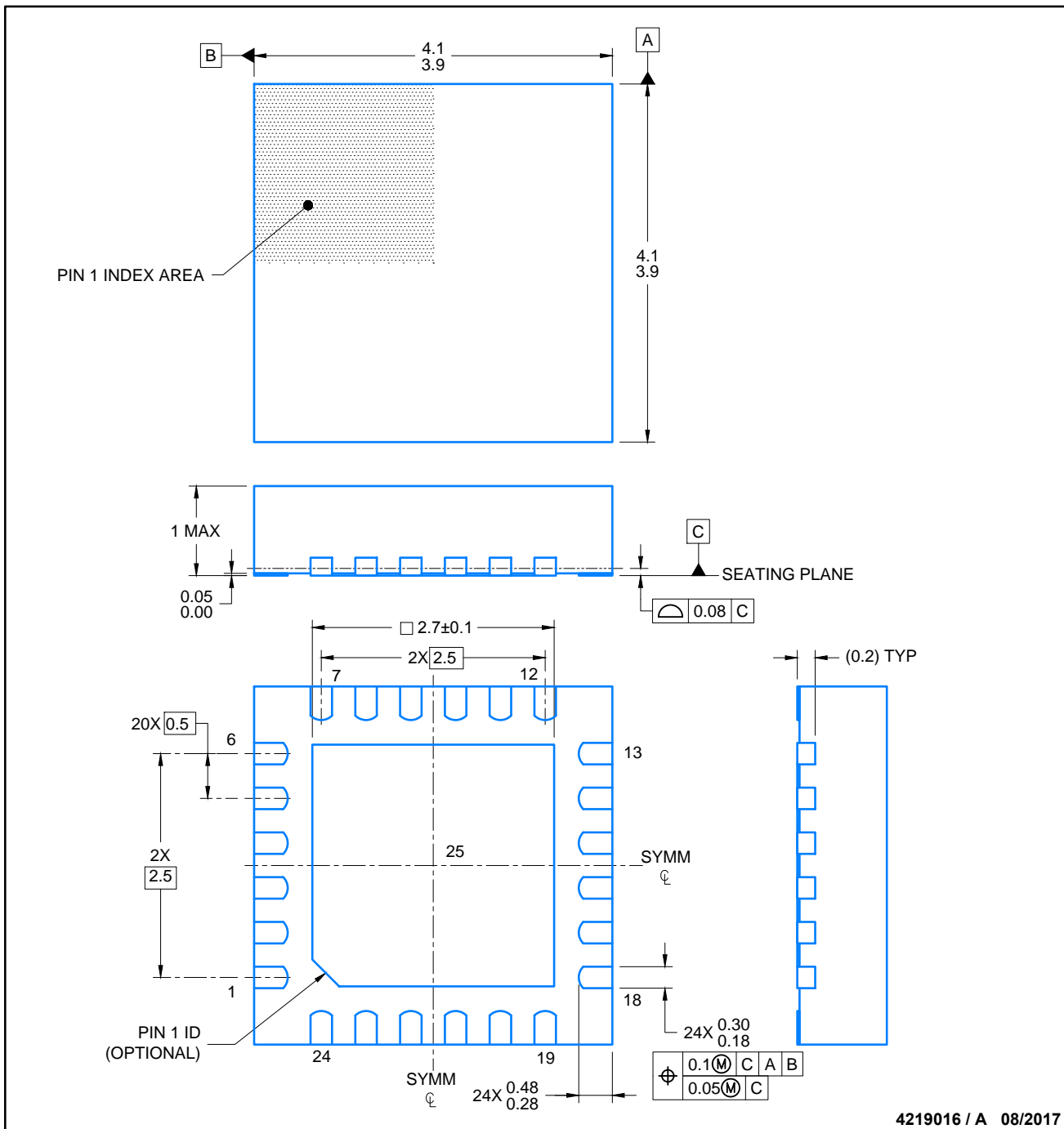

NOTES:

1. All linear dimensions are in millimeters. Any dimensions in parenthesis are for reference only. Dimensioning and tolerancing per ASME Y14.5M.
2. This drawing is subject to change without notice.
3. The package thermal pad must be soldered to the printed circuit board for thermal and mechanical performance.

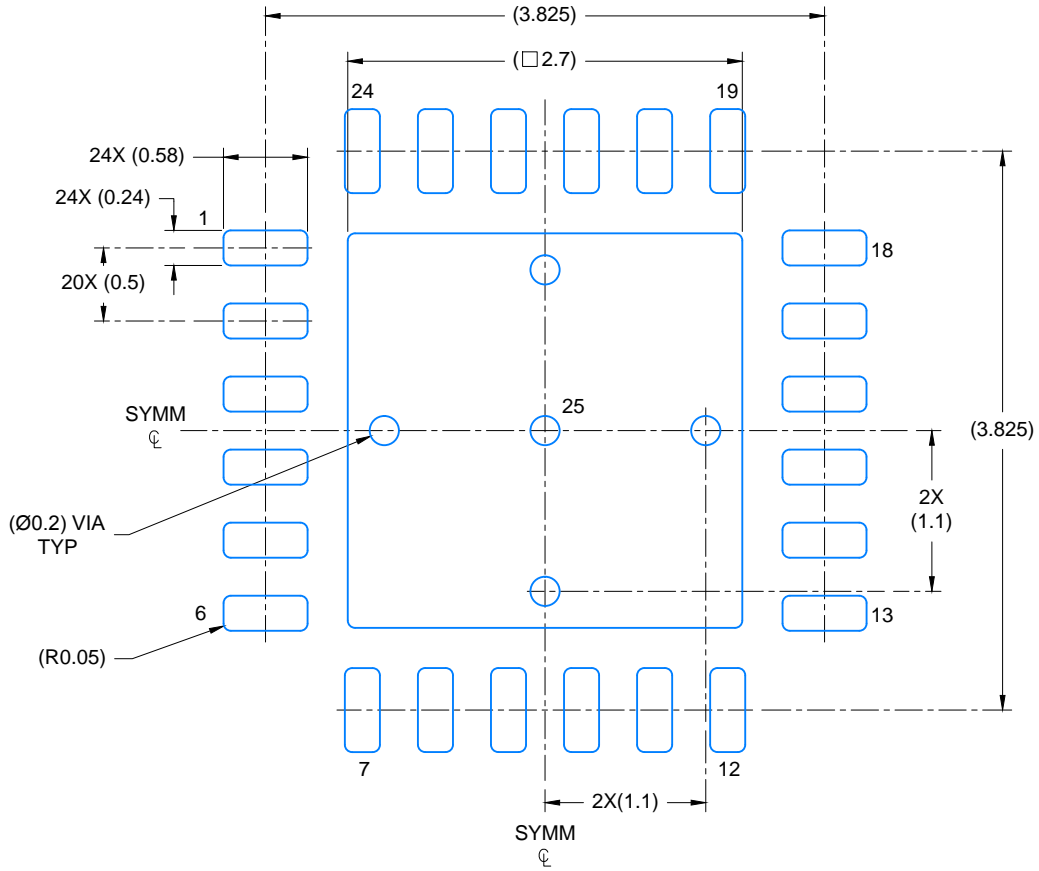

LAND PATTERN EXAMPLE  
SCALE: 20X

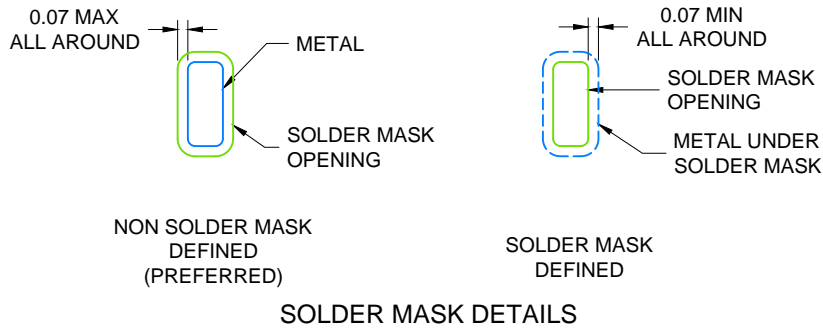

4219016 / A 08/2017

NOTES: (continued)

4. This package is designed to be soldered to a thermal pad on the board. For more information, see Texas Instruments literature number SLUA271 ([www.ti.com/lit/slua271](http://www.ti.com/lit/slua271)).
5. Solder mask tolerances between and around signal pads can vary based on board fabrication site.

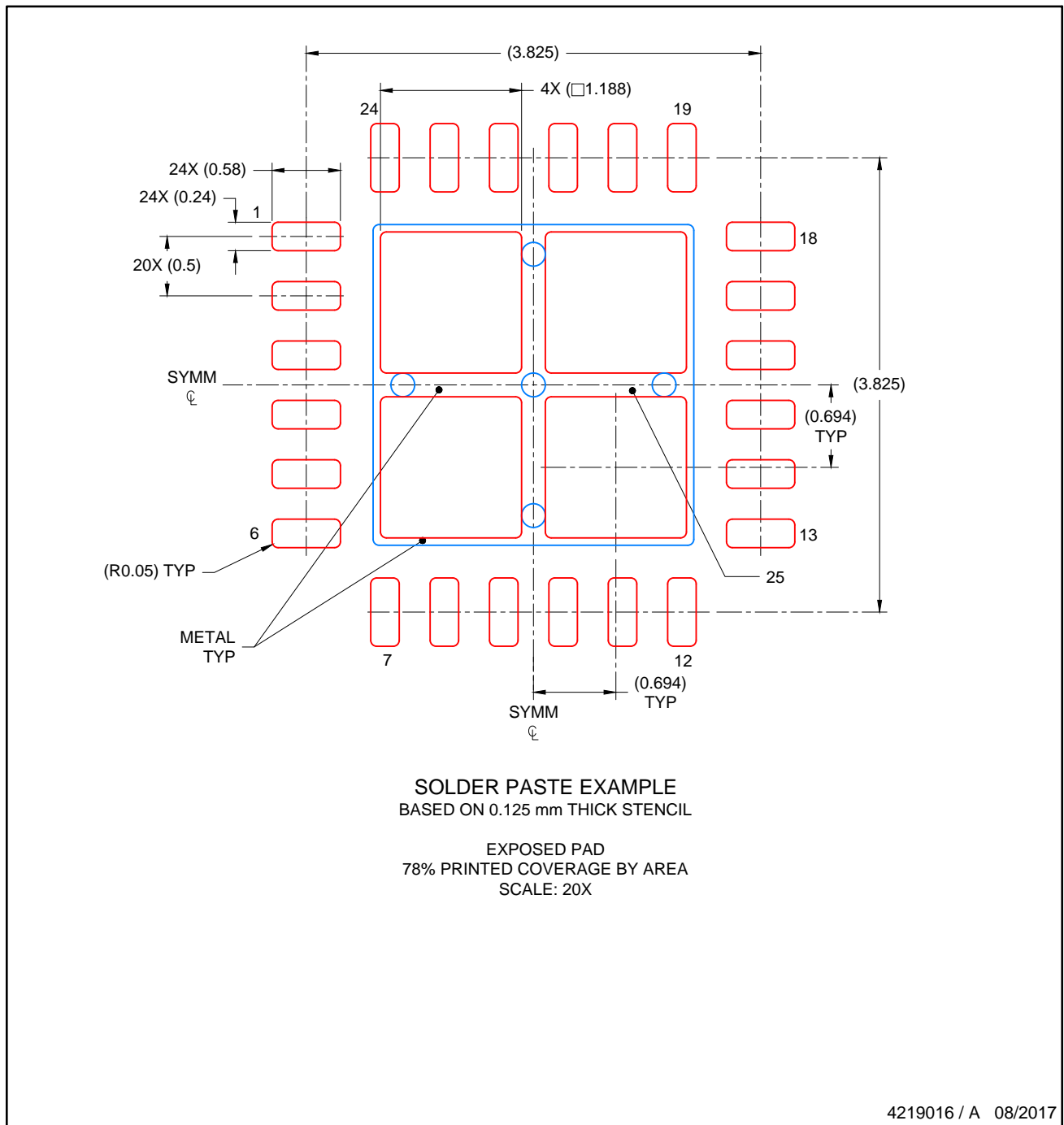

NOTES: (continued)

- 6. Laser cutting apertures with trapezoidal walls and rounded corners may offer better paste release. IPC-7525 may have alternate design recommendations..

## 重要声明和免责声明

TI“按原样”提供技术和可靠性数据（包括数据表）、设计资源（包括参考设计）、应用或其他设计建议、网络工具、安全信息和其他资源，不保证没有瑕疵且不做任何明示或暗示的担保，包括但不限于对适销性、某特定用途方面的适用性或不侵犯任何第三方知识产权的暗示担保。

这些资源可供使用 TI 产品进行设计的熟练开发人员使用。您将自行承担以下全部责任：(1) 针对您的应用选择合适的 TI 产品，(2) 设计、验证并测试您的应用，(3) 确保您的应用满足相应标准以及任何其他功能安全、信息安全、监管或其他要求。

这些资源如有变更，恕不另行通知。TI 授权您仅可将这些资源用于研发本资源所述的 TI 产品的应用。严禁对这些资源进行其他复制或展示。您无权使用任何其他 TI 知识产权或任何第三方知识产权。您应全额赔偿因在这些资源的使用中对 TI 及其代表造成的任何索赔、损害、成本、损失和债务，TI 对此概不负责。

TI 提供的产品受 [TI 的销售条款](#) 或 [ti.com](#) 上其他适用条款/TI 产品随附的其他适用条款的约束。TI 提供这些资源并不会扩展或以其他方式更改 TI 针对 TI 产品发布的适用的担保或担保免责声明。

TI 反对并拒绝您可能提出的任何其他或不同的条款。

邮寄地址：Texas Instruments, Post Office Box 655303, Dallas, Texas 75265  
Copyright © 2021，德州仪器 (TI) 公司

## X-ON Electronics

Largest Supplier of Electrical and Electronic Components

*Click to view similar products for [Hot Swap Voltage Controllers](#) category:*

*Click to view products by [Texas Instruments](#) manufacturer:*

Other Similar products are found below :

[LT4256-1CS8#TRPBF](#) [HIP1011BCBZA](#) [ISL6119HIBZA](#) [ISL6141IBZA](#) [ISL6151CBZA-T](#) [ISL61851ACBZ](#) [ISL61851BCBZ](#)  
[ISL61851BIBZ-T](#) [ISL61851CCBZ](#) [ISL61851DCBZ](#) [ISL61851GCBZ](#) [ISL61851HCBZ](#) [ISL61851ICBZ](#) [ISL61851KCBZ](#) [TPS25961DRVR](#)  
[TPS26612DDFR](#) [LM74700MDDFREP](#) [TPS23880RTQR](#) [MP5991GLU-Z](#) [MP5048GU-Z](#) [TPS259822LNRGER](#) [TPS259461ARPWR](#)  
[TPS16530RGER](#) [LT4256-3IGN#TRPBF](#) [LT1641IS8#TRPBF](#) [LTC4218IGN#TRPBF](#) [LTC4210-1CS6#TRPBF](#) [LTC4211IMS8#TRPBF](#)  
[RT1720GF](#) [TPS259827ONRGER](#) [TPS259823ONRGER](#) [LM74502QDDFRQ1](#) [LM5068MMX-2/NOPB](#) [LM74502HQDDFRQ1](#)  
[TPS25210LRPWR](#) [TPS26601RHFR](#) [TPS26611DDFR](#) [TPS259472ARPWR](#) [LM74500QDDFRQ1](#) [TPS26610DDFR](#) [TPS259460ARPWR](#)  
[LM5066IPMHX/NOPB](#) [TPS259824LNRGER](#) [TPS259823LNRGER](#) [NU6-II 60kA/385V 4P](#) [NU6-G 40kA/275V 4P](#) [NU6-II 40kA/385V 2P](#)  
[TPS26635RGER](#) [AL6-NFNFBW-9](#) [AL-ECF504-AA24](#)