

带有可编程涌入转换率的 3V 至 20V 高电流负载开关

 查询样品: [TPS25910](#)

特性

- 3V 至 20V 总线运行电压
- 集成的 30mΩ 导通金属氧化物半导体场效应晶体管 (MOSFET)
- 可编程电流限制从: **0.83A 至 6.5A**
- 可编程涌入电流转换率
- 热关断和故障警报
- 4mm x 4mm 四方扁平无引线 (QFN)-16 封装
- -40°C 至 125°C 的结温范围

应用范围

- 固态硬盘 (SSD)
- 硬盘驱动器 (HDD)
- RAID 阵列
- 电信
- 插入式电路板
- 笔记本电脑和上网本

说明

TPS25910 器件在负载电源电压为 3V 和 20V 的应用中提供高度集成的热插拔电源管理和出色的保护。这个器件用于必须在有害的持续和瞬态过载时对电压总线提供保护的系统。

在启动时或热插入系统总线时, TPS25910 通过控制输出电压, V_{OUT} , 来限制涌入电流。可使用 GATE 引脚和 GND 引脚之间的一个电容器来调节 V_{OUT} 的转换率。

内置 SOA 保护可确保内部 MOSFET 在最恶劣的工作条件下在一个安全运行区间 (SOA) 内运行。此外, 可使用 ILIM 引脚与 GND 引脚之间的一个电阻器来调节与功率限值无关的电流限制阈值。

TPS25910 在过热故障时提供一个故障指示器输出。

TPS25910 采用 16 引脚四方扁平无引线 (QFN) 封装。

12-V, 4.75-A APPLICATION

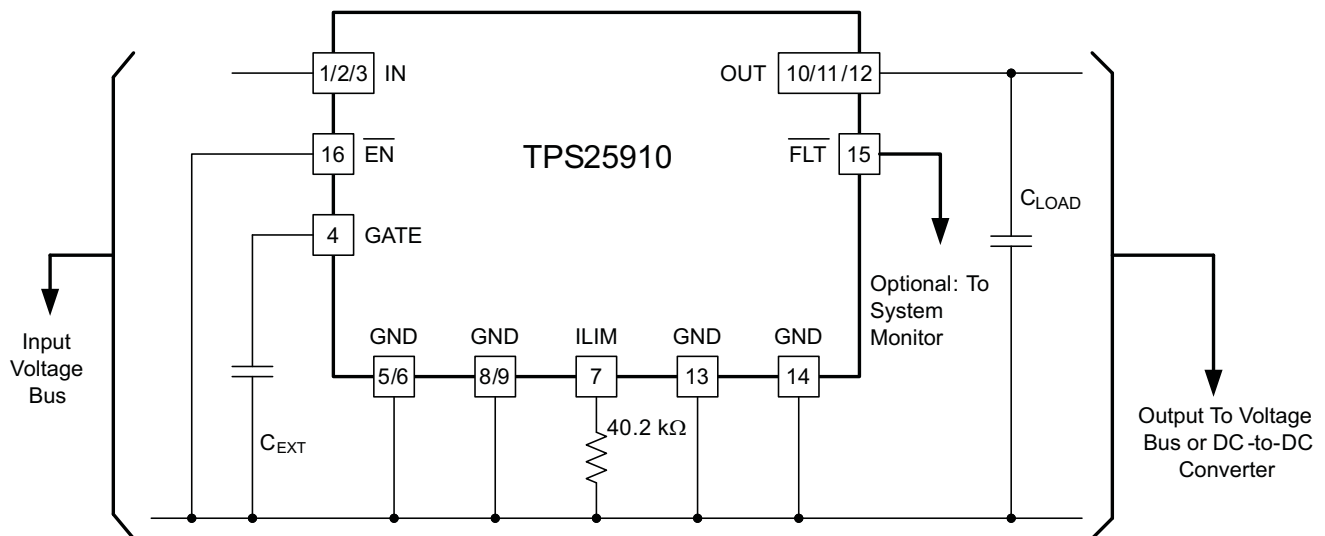

Please be aware that an important notice concerning availability, standard warranty, and use in critical applications of Texas Instruments semiconductor products and disclaimers thereto appears at the end of this data sheet.



These devices have limited built-in ESD protection. The leads should be shorted together or the device placed in conductive foam during storage or handling to prevent electrostatic damage to the MOS gates.

ORDERING INFORMATION

DEVICE	JUNCTION TEMPERATURE	PACKAGE	ORDERING CODE	MARKING
TPS25910	-40°C to 125°C	RSA (4-mm x 4-mm QFN)	TPS25910RSAR	TPS25910
			TPS25910RSAT	

ABSOLUTE MAXIMUM RATINGS

over device junction temperature range (unless otherwise noted)⁽¹⁾⁽²⁾

	MIN	MAX	UNIT
Input voltage range IN, OUT	-0.3	22	V
Voltage range, GATE	-0.3	30	
Voltage range \overline{FLT}	-0.3	20	V
Voltage ILIM		1.75	
Output sink current \overline{FLT}		10	mA
Input voltage range, \overline{EN}	-0.3	6	
Voltage range ILIM ⁽³⁾	-0.3	3	V
ESD rating, HBM		2 .5 k	
ESD rating, CDM		500	
Operating junction temperature range, T_J	Internally Limited		°C
Storage temperature range, T_{stg}	-65	150	

- (1) Stresses beyond those listed under “absolute maximum ratings” may cause permanent damage to the device. These are stress ratings only, and functional operation of the device at these or any other conditions beyond those indicated under “recommended operating conditions” is not implied. Exposure to absolute–maximum–rated conditions for extended periods may affect device reliability.
- (2) All voltage values are with respect to GND.
- (3) Do not apply voltage to pin.

RECOMMENDED OPERATING CONDITIONS

over device junction temperature range (unless otherwise noted)

PARAMETER	MIN	NOM	MAX	UNIT
Input voltage range V_{IN} , V_{OUT}	3		20	V
Voltage range \overline{EN}	0		5	
Voltage range \overline{FLT}	0		20	
Continuous output current I_{OUT}	0		5	A
Output sink current \overline{FLT}	0		1	mA
External Capacitor, GATE	1		47	nF
dV/dt , $V_{IN}^{(1)}$			12	V/ μ S
$R_{LIM}^{(2)}$	0		237k	Ω
Junction temperature	-40		125	$^{\circ}$ C

 (1) dV/dt , V_{IN} should be limited to 12 V/ μ S to confine the shoot-through current to the load.

 (2) When R_{LIM} value is beyond this range, I_{LIM} will not be as accurate as within this range.

THERMAL INFORMATION

THERMAL METRIC ⁽¹⁾		TPS25910	UNITS
		RSA (QFN)	
		16 PINS	
θ_{JA}	Junction-to-ambient thermal resistance ⁽²⁾	34.8	$^{\circ}$ C/W
θ_{JCTop}	Junction-to-case (top) thermal resistance ⁽³⁾	35.3	
θ_{JB}	Junction-to-board thermal resistance ⁽⁴⁾	11.9	
ψ_{JT}	Junction-to-top characterization parameter ⁽⁵⁾	0.4	
ψ_{JB}	Junction-to-board characterization parameter ⁽⁶⁾	12.0	
θ_{JCbott}	Junction-to-case (bottom) thermal resistance ⁽⁷⁾	3.3	

 (1) 有关传统和新的热度的更多信息，请参阅IC封装热量应用报告，[SPRA953](#)。

(2) 在 JESD51-2a 描述的环境中，按照 JESD51-7 的指定，在一个 JEDEC 标准高 K 电路板上进行仿真，从而获得自然对流条件下的结至环境热阻。

(3) 通过在封装顶部模拟一个冷板测试来获得结至芯片外壳（顶部）的热阻。不存在特定的 JEDEC 标准测试，但可在 ANSI SEMI 标准 G30-88 中找到内容接近的说明。

(4) 按照 JESD51-8 中的说明，通过在配有用于控制 PCB 温度的环形冷板夹具的环境中进行仿真，以获得结板热阻。

 (5) 结至顶部特征参数， ψ_{JT} ，估算真实系统中器件的结温，并使用 JESD51-2a（第 6 章和第 7 章）中描述的程序从仿真数据中提取出该参数以便获得 θ_{JA} 。

 (6) 结至电路板特征参数， ψ_{JB} ，估算真实系统中器件的结温，并使用 JESD51-2a（第 6 章和第 7 章）中描述的程序从仿真数据中提取出该参数以便获得 θ_{JA} 。

(7) 通过在外露（电源）焊盘上进行冷板测试仿真来获得结至芯片外壳（底部）热阻。不存在特定的 JEDEC 标准测试，但可在 ANSI SEMI 标准 G30-88 中找到内容接近的说明。

ELECTRICAL CHARACTERISTICS

Over operating free-air temperature range, $V_{IN} = 3\text{ V} - 20\text{ V}$, $\overline{EN} = 0\text{ V}$, $\overline{FLT} = \text{open}$, $R_{(RLIM)} = 40.2\text{ k}\Omega$, No external capacitors are connected to either GATE or OUT, (unless otherwise noted)

PARAMETER		TEST CONDITIONS	MIN	TYP	MAX	UNIT
IN						
	UVLO	$V_{IN} \uparrow$	2.60	2.75	2.90	V
		Hysteresis		100		mV
	Bias current	$\overline{EN} = 2.4\text{ V}$		2.5	4	mA
		$\overline{EN} = 0\text{ V}$		3.3	5	
OUT						
	RON	$R_{(VIN-VOUT)}$, $I_{(VOUT)} < I_{(RLIM)}$, $1\text{ A} \leq I_{(VOUT)} \leq 4.5\text{ A}$		29.5	42	mΩ
	Power limit	$V_{IN}: 12\text{ V}$, $C_{OUT} = 1000\text{ }\mu\text{F}$, $\overline{EN}: 3\text{ V} \rightarrow 0\text{ V}$	3	5	7.5	W
	Reverse diode voltage	$V_{OUT} > V_{IN}$, $\overline{EN} = 5\text{ V}$, $I_{IN} = -1\text{ A}$		0.77	1	V
ILIM						
	Current limit program $I_{(VOUT)}$, $V_{(VIN - OUT)} = 0.3\text{ V}$, pulsed test	$R_{(RLIM)} = 237\text{ k}\Omega$	0.50	0.82	1.1	A
		$R_{(RLIM)} = 200\text{ k}\Omega$	0.75	1	1.25	
		$R_{(RLIM)} = 100\text{ k}\Omega$	1.75	2	2.25	
		$R_{(RLIM)} = 66.5\text{ k}\Omega$	2.65	3	3.3	
		$R_{(RLIM)} = 40.2\text{ k}\Omega$	4.50	5	5.5	
		$R_{(RLIM)} = 29.4\text{ k}\Omega$	5.70	6.50	7.3	
EN						
	Threshold voltage	$V_{(\overline{EN})}$ falling	1.10	1.35		V
		$V_{(\overline{EN})}$ rising		1.50	1.75	
		Hysteresis		150		mV
	Input bias current	$V_{(\overline{EN})} = 2.4\text{ V}$ (sinking)	-1.5	-1	0.5	μA
		$V_{(\overline{EN})} = 0.2\text{ V}$ (sourcing)	-2	-1	0.5	
	Turn on propagation delay	$V_{IN} = 3.3\text{ V}$, $I_{LOAD} = 1\text{ A}$, $V_{(\overline{EN})}: 2.4\text{ V} \rightarrow 0.2\text{ V}$, till I_{GATE} changes direction.		10		μs
	Turn off propagation delay	$V_{IN} = 3.3\text{ V}$, $I_{LOAD} = 1\text{ A}$, $V_{(\overline{EN})}: 0.2\text{ V} \rightarrow 2.4\text{ V}$, till I_{GATE} changes direction.		2.5		
FLT						
	V_{OL}	$I_{(FLT)} = 1\text{ mA}$, Fault active (Over Temperature)		0.2	0.4	V
	Leakage current	$V_{(FLT)} = 18\text{ V}$			1	μA
THERMAL SHUTDOWN						
	Thermal shutdown	T_J		160		°C
		Hysteresis		20		
GATE						
	Sourcing current	$V_{(GATE-OUT)} = 3.5\text{ V}$, $V_{(\overline{EN})} = \text{Low}$	8	11	15	μA
	Strong pull down resistor	$V_{(\overline{EN})} = \text{Low}$	10	40	80	Ω
	Weak pull down current	$V_{(\overline{EN})} = \text{Low}$	250	500	750	μA
	Output Voltage, $V_{(GATE-OUT)}$		5.5	6.6	7.5	V

DEVICE INFORMATION

TPS25910 FUNCTIONAL BLOCK DIAGRAM

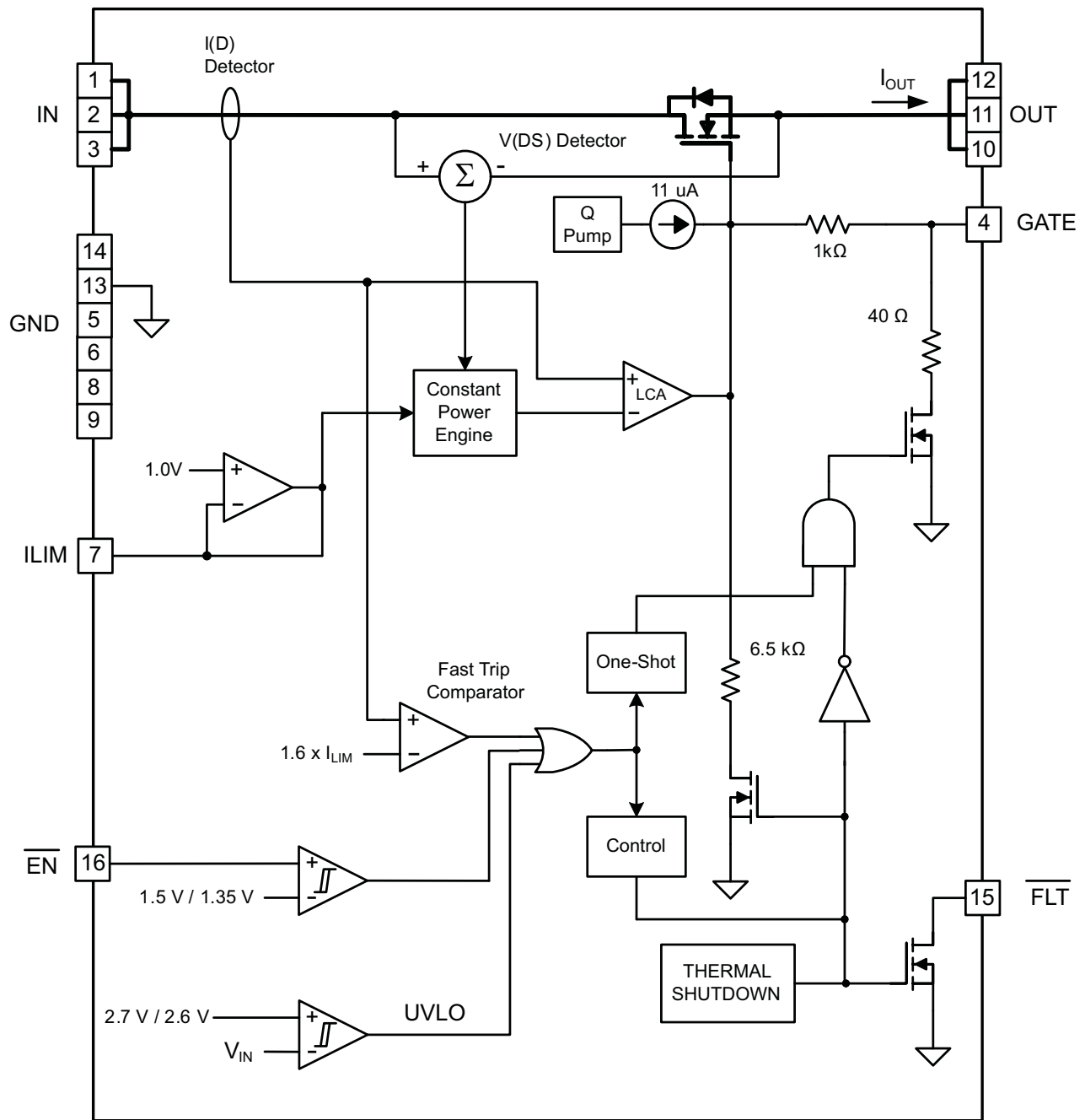
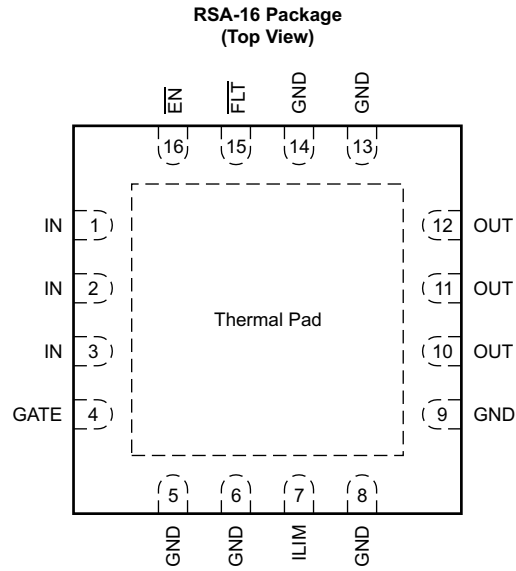

Figure 1. Functional Block Diagram

TPS25910 PIN ASSIGNMENT



PIN FUNCTIONS

PIN NAME	PIN NUMBER	DESCRIPTION
\overline{EN}	16	Device is enabled when this pin is pulled low.
IN	1, 2, 3	Power In and control supply voltage.
GATE	4	If the chip die temperature exceeds the OTSD rising threshold, GATE is pulled down to GND by a 7.5KOhm resistor.
ILIM	7	A resistor to ground sets the current limit level.
GND	5, 6, 8, 9, 13, 14	GND
OUT	10, 11, 12	Output to the load.
\overline{FLT}	15	Fault low indicates that the internal pass FET junction temperature exceeds the thermal shutdown threshold

PIN DESCRIPTION

FLT: Open-drain output that pulls low during thermal shutdown. $\overline{\text{FLT}}$ activates when device thermally shuts down and deactivates when die temperature cools down below the device thermal protection threshold and the device ends thermal shutdown cycle. FLT becomes operational before UV, when V_{IN} is greater than 1V.

GND: This is the most negative voltage in the circuit and is used as reference for all voltage measurements unless otherwise specified. All the GND pins must be connected to system power supply negative return point

GATE: Output that provides gate drive for the internal pass FET. Its sourcing current is about 11 μA . An internal clamp prevents GATE from rising 6.6 V above OUT. C_{INT} is 200 pF.

The GATE pin is disabled by the following mechanisms:

1. When $\overline{\text{EN}}$ is above its rising threshold, GATE is pulled down by a 40- Ω resistor connecting to GND for approximately 50 μs . Then, a 7.5-k Ω resistor ties GATE to GND to ensure the GATE is off.
2. When V_{IN} drops below the UVLO threshold, GATE is pulled down by a 40- Ω resistor connecting to GND for approximately 50 μs . Then, a 7.5-k Ω resistor ties GATE to GND to ensure the GATE is off.
3. When short circuit fault occurs, GATE is pulled down by a 40- Ω resistor connecting to GND for approximately 50 μs . Then, a 500 μA current source continues to pull down on the GATE.
4. If the chip die temperature exceeds the OTSD rising threshold, GATE is pulled down to GND by a 7.5-k Ω resistor.

An external capacitor can be connected from GATE pin to GND pin to create linear inrush profile. The slew rate of the inrush can be controlled by a different capacitor value.

$$I_{\text{CHARGE}} = (C_{\text{EXT}} + C_{\text{INT}}) \frac{dV_{\text{OUT}}}{dt} \quad (1)$$

Where:

I_{CHARGE} is 11 μA (typical)

C_{INT} , the equivalent gate input capacitance of the internal FET (200 pF typical).

ILIM: A resistor connected from this pin to ground sets $I_{(\text{LIM})}$. R_{LIM} is set by the formula:

$$R_{\text{LIM}} = \frac{197.388}{I_{\text{LIM}}^{0.976944}} \quad \text{for currents below 2 A where } R_{\text{LIM}} \text{ is in k}\Omega. \quad (2)$$

$$R_{\text{LIM}} = \frac{205.62}{I_{\text{LIM}}^{1.02912}} \quad \text{for currents above 2 A where } R_{\text{LIM}} \text{ is in k}\Omega. \quad (3)$$

EN: When this pin is pulled low, the device is enabled. The input threshold is hysteretic, allowing the user to program a startup delay with an external RC circuit. $\overline{\text{EN}}$ is pulled to V_{IN} by a 10-M Ω resistor, pulled to GND by 16.8 M Ω and is clamped to ground by a 7-V Zener diode. Because high impedance pullup and or down resistors are used to reduce current draw, any external FET controlling this pin should be low leakage.

IN: Input voltage to the TPS25910. The recommended operating voltage range is 3 V to 20 V. All V_{IN} pins should be connected together and to the power source.

OUT: Output connection for the TPS25910. When switched on, the output voltage is approximately:

$$V_{\text{OUT}} = V_{\text{IN}} - 0.04 \times I_{\text{OUT}} \quad (4)$$

All OUT pins should be connected together and to the load.

TYPICAL CHARACTERISTICS

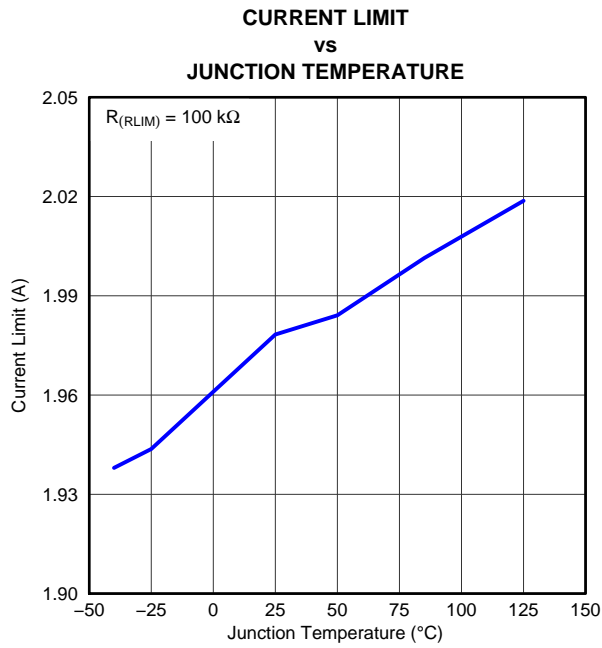

Figure 2.

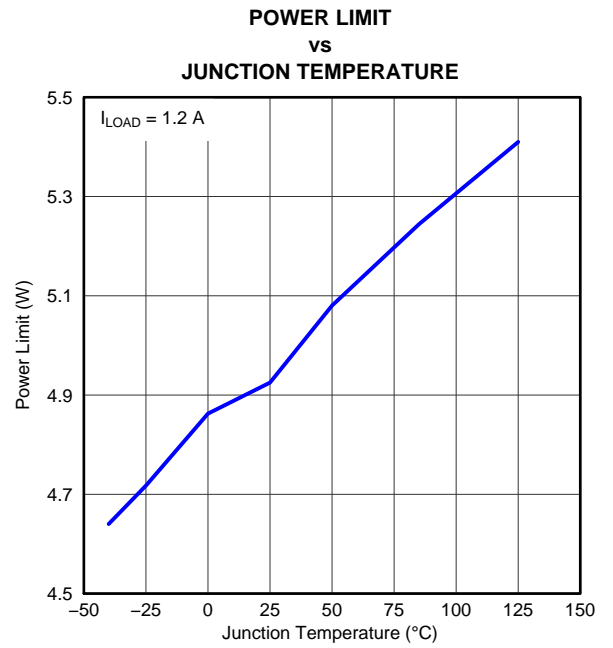

Figure 3.

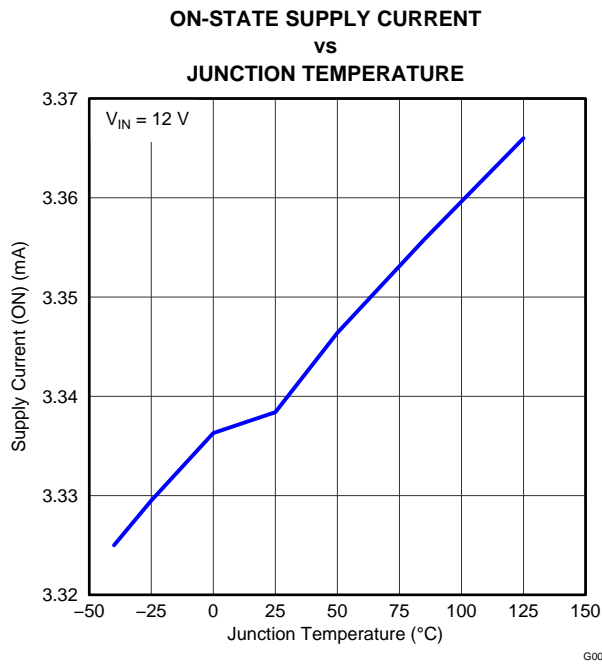

Figure 4.

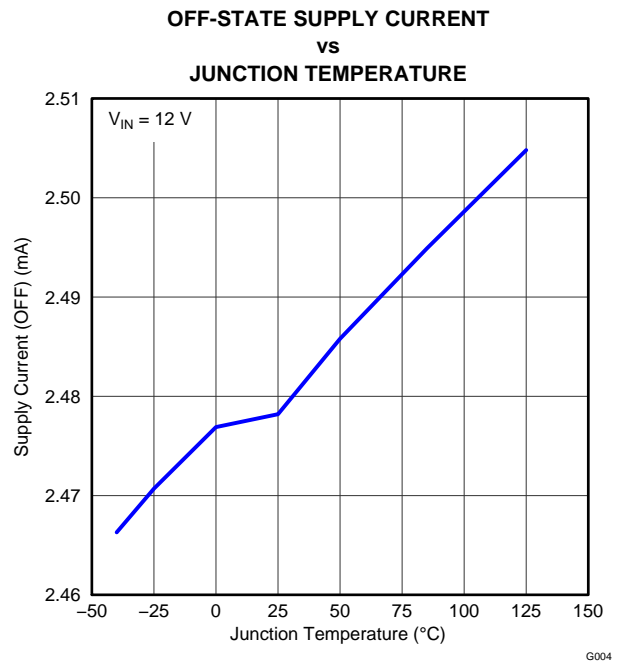

Figure 5.

APPLICATION INFORMATION

Programming the Current-Limit Threshold

The over-current threshold is user programmable via an external resistor. The TPS25910 uses an internal regulation loop to provide a regulated voltage on the ILIM pin. The current-limit threshold is proportional to the current sourced out of ILIM. The recommended 1% resistor range for R_{LIM} is $0\text{ k}\Omega \leq R_{LIM} \leq 237\text{ k}\Omega$ to ensure stability of the internal regulation loop. Many applications require that the minimum current limit is above a certain current level or that the maximum current limit is below a certain current level, so it is important to consider the tolerance of the over-current threshold when selecting a value for R_{LIM} . Consult the Electrical Characteristics table for specific current limit settings. The traces routing the R_{LIM} resistor to the TPS25910 should be as short as possible to reduce parasitic effects on the current-limit accuracy.

Equation 5 through Equation 7 can be used to estimate current limit below 2 A:

$$I_{LIM(min)} = \frac{1051.9}{R_{LIM(max)}^{1.3854}} \quad (5)$$

$$I_{LIM(typ)} = \frac{223.61}{R_{LIM(typ)}^{1.0236}} \quad (6)$$

$$I_{LIM(max)} = \frac{104.95}{R_{LIM(min)}^{0.8347}} \quad (7)$$

Equation 8 through Equation 10 can be used to estimate current limit above 2 A:

$$I_{LIM(min)} = \frac{161.24}{R_{LIM(max)}^{0.9796}} \quad (8)$$

$$I_{LIM(typ)} = \frac{176.85}{R_{LIM(typ)}^{0.9717}} \quad (9)$$

$$I_{LIM(max)} = \frac{194.81}{R_{LIM(min)}^{0.9694}} \quad (10)$$

where $R_{LIM(max)}$ is the maximum resistor value in factoring in error, $R_{LIM(typ)}$ is the typical resistor value, and $R_{LIM(min)}$ is the minimum resistor value factoring in error. All resistor values are represented in $\text{k}\Omega$. For example, a 100- $\text{k}\Omega$, 1% resistor would have the following values:

- $R_{LIM(min)} = 99\text{ k}\Omega$
- $R_{LIM(typ)} = 100\text{ k}\Omega$
- $R_{LIM(max)} = 101\text{ k}\Omega$

A plot of the current limit threshold vs. RLIM using equations Equation 5 through Equation 10 above is shown in Figure 6.

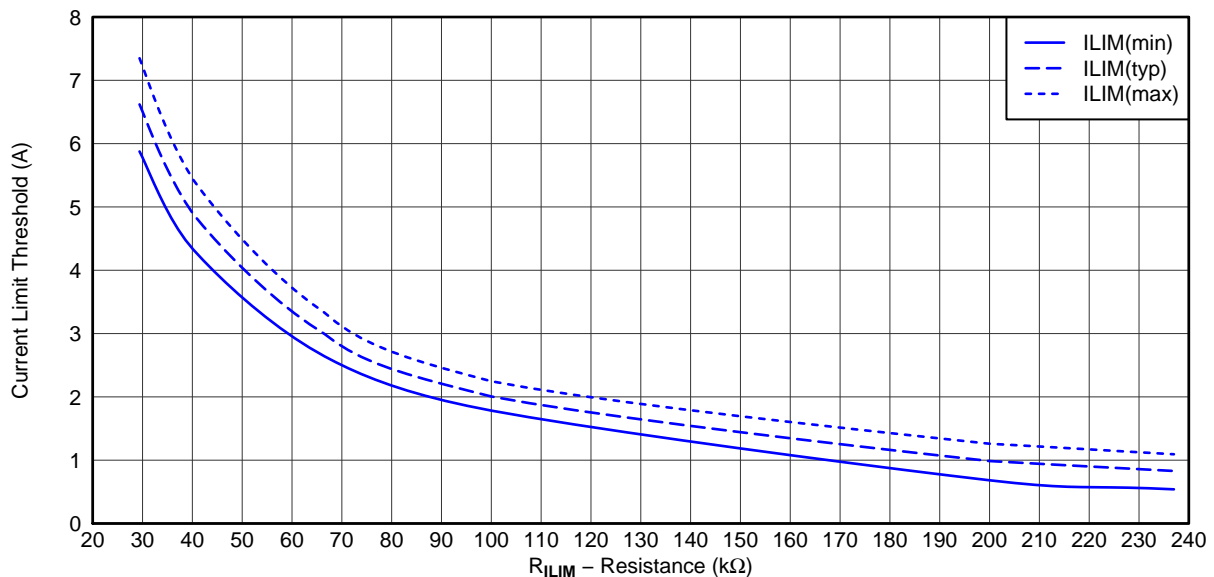

Figure 6. Current Limit Threshold vs. RLIM

G001

Slew Rate Control Using C_{GATE}

The TPS25910 can be used with applications that require constant turn-on currents. The current is controlled by a single capacitor from the GATE terminal to ground. The TPS25910 internal MOSFET appears to operate as a source follower (following the gate voltage) in this implementation. Choose a time to charge, Δt, based on the output capacitor, input voltage V_I, and desired charge current, I_{CHARGE}. Select the device load to be less than 5 W ÷ V_{IN}.

$$\Delta t = \frac{C_{LOAD} \times V_{IN}}{I_{C-LOAD}} \tag{11}$$

To select the gate capacitance:

$$C_{EXT} = I_{CHARGE} \times \frac{\Delta t}{V_{IN}} - C_{INT} \tag{12}$$

- I_{CHARGE} = 11 μA
- C_{INT} = 200 pF (typical)

Figure 7 and Figure 8 illustrate the effects of C_{EXT} = 0.1 μF on inrush current using TPS25910EVM-088.

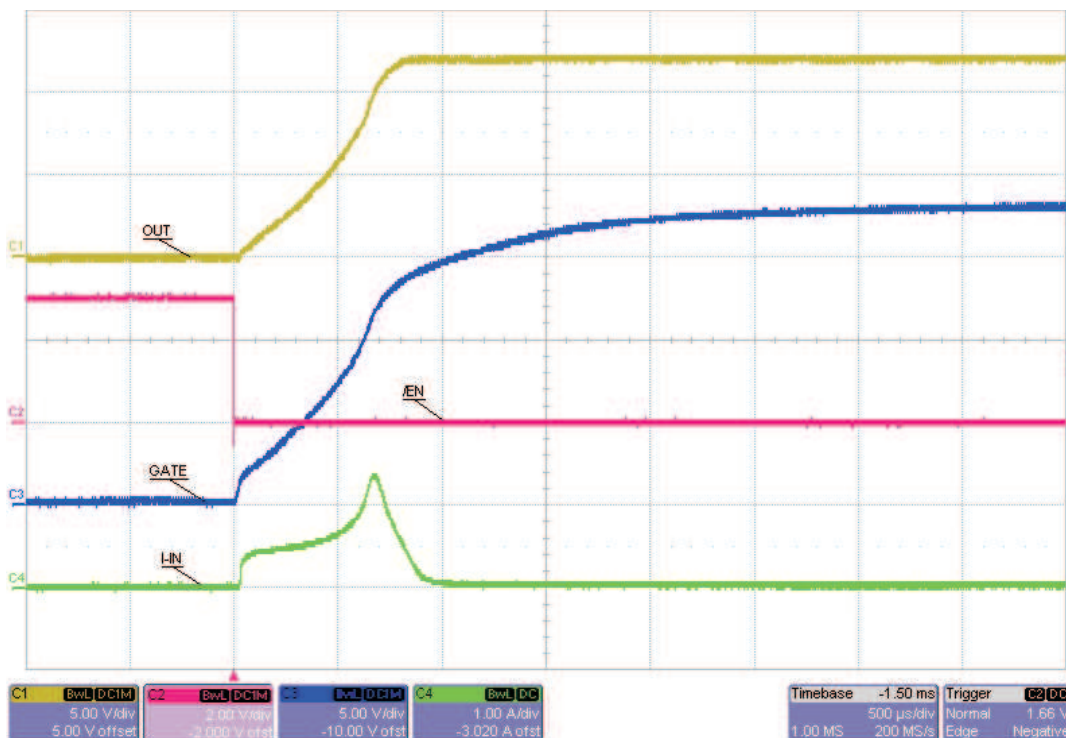

Figure 7. Typical Power Limited Inrush Start Up (no C_{EXT})

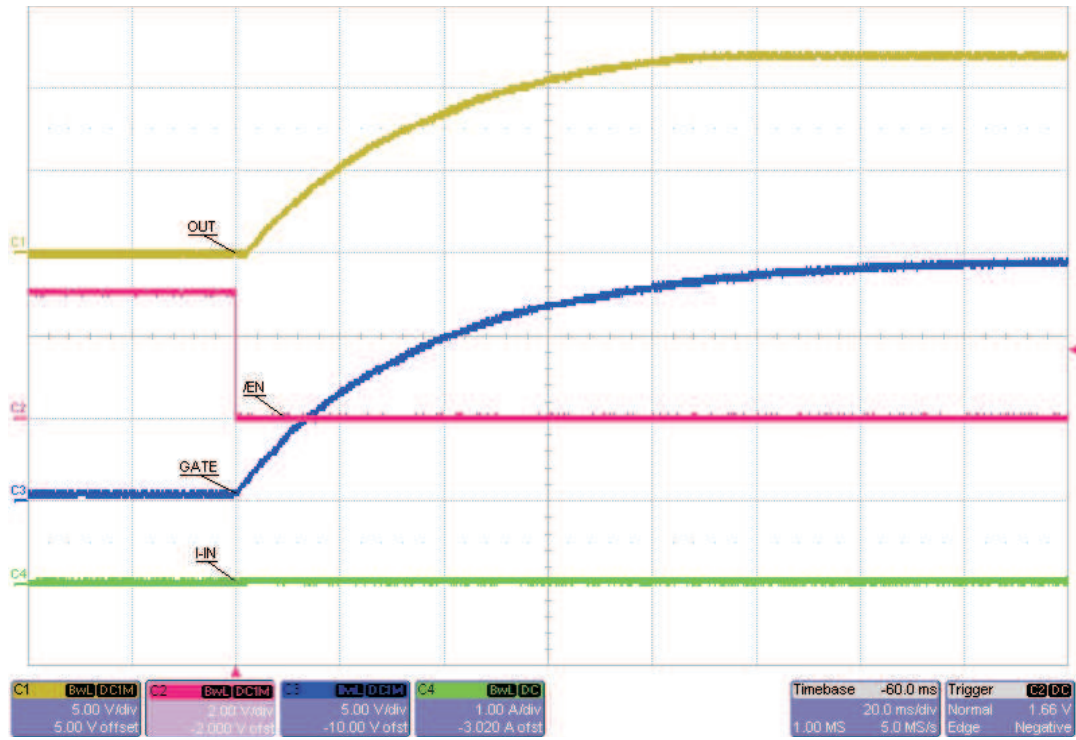

Figure 8. Start Up With Slew Rate Control ($C_{EXT} = 0.1 \mu\text{F}$)

Thermal Sense

The TPS25910 self protects by using a thermal sensing circuit that monitors the operating temperature of the power switch and disables operation if the temperature exceeds the thermal shutdown condition (160°C typical). The TPS25910 device operates in power-limit mode during an overload condition and increases the voltage drop across power switch. The thermal sensor turns off the power switch when the die temperature exceeds 160°C. Hysteresis is built into the thermal sensor, and the switch turns on after the device has cooled approximately 20°C. Figure 9 below illustrates the thermal behavior during output overload.

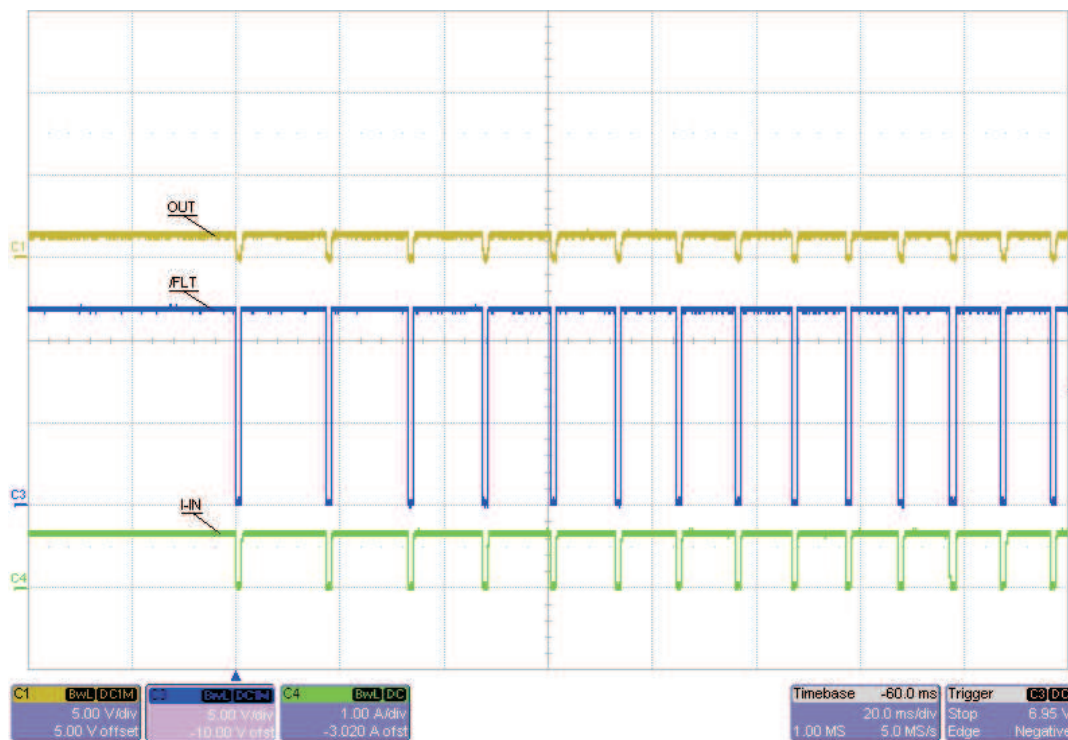

Figure 9. Thermal Sense Behavior

Back-to-Back (B2B) FET Operation

Many applications require reverse current blocking (from load to input source) so that pending system activities can be completed (such as writing important data to non-volatile memory) prior to power down or during brown out. TPS25910 provides the GATE pin externally for slew rate control, but this external connection can also be used to control an external blocking MOSFET, Q1 as shown in Figure 10.

As V_{IN} drops during input power removal, the comparator circuit de-asserts ENb, GATE falls, and both the TPS25910 internal MOSFET and Q1 is turned off and block any current flow from V_{LOAD} to V_{IN} . C_{LOAD} can then be chosen to furnish the required load current for long enough to complete the required power down system activities.

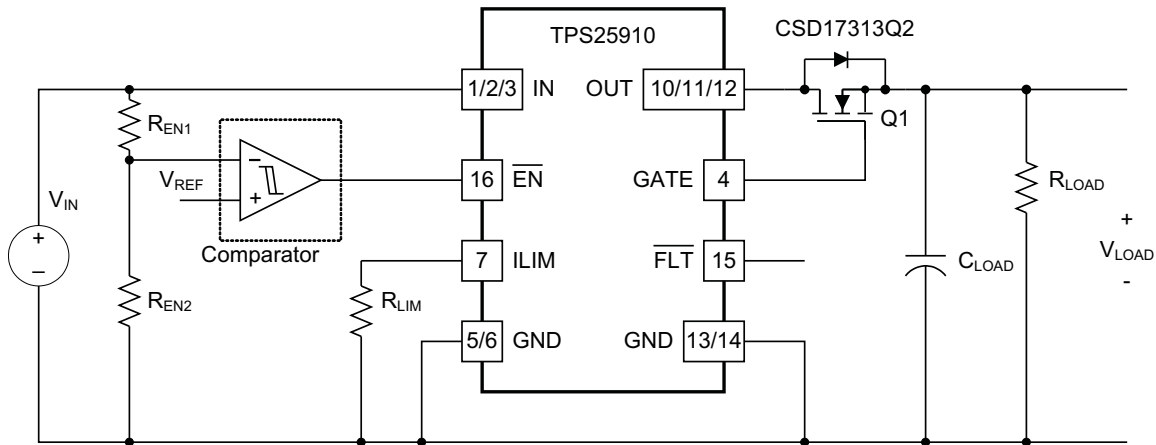

Figure 10. B2B Implementation

NOTE

Connecting the load voltage to the non-inverting input of the external comparator can provide a simple ORing function that prevents holdup energy in C_{LOAD} from discharging through the TPS25910 to $V_{IN(source)}$ when $V_{IN(source)}$ droops or collapses.

Circuit operation is illustrated in Figure 11 and Figure 12. Figure 11 shows the power down event with no load at the output. When V_{IN} drops to approximately 10 V (threshold of comparator circuit), ENb is de-asserted and GATE falls and enables reverse current blocking. The voltage on C_{LOAD} then stops following V_{IN} and remains flat for a long duration.

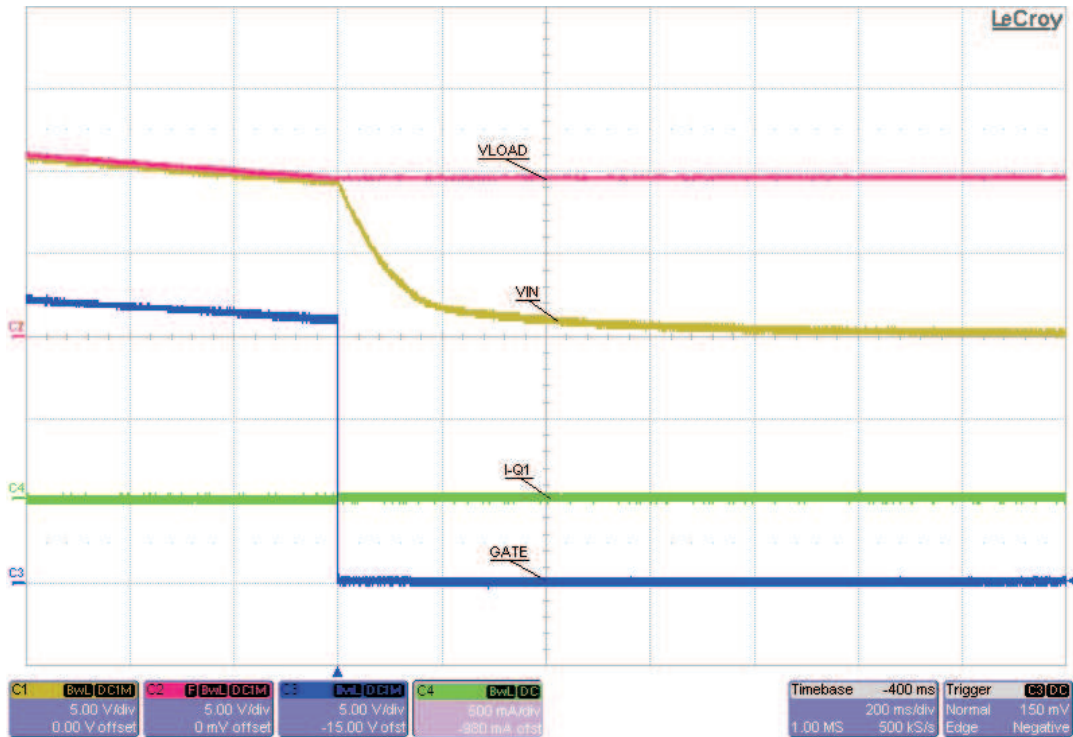

Figure 11. B2B Performance with No-Load

Maximum Load at Startup

The power limiting function of the TPS25910 provides effective protection for the internal FET. Expectedly, there is a supply voltage dependent maximum load which the device is able to power up. Loads above this level may cause the device to shut off current before startup is complete. Neglecting any load capacitance, the maximum load (minimum load resistance) is calculated using Equation 13;

$$R_{\text{MIN}} = \frac{V_{\text{IN}}^2}{12} \quad (13)$$

Adding load capacitance may reduce the maximum load which can be present at start up.

If $\overline{\text{EN}}$ is tied to GND at startup and IN does not ramp quickly, the TPS25910 may momentarily turn off then on during startup. This can happen if a capacitive load pulls down the input voltage below the UV threshold. If necessary, this can be avoided by delaying the $\overline{\text{EN}}$ assertion until VIN is fully up.

Transient Protection

The need for transient protection in conjunction with hot-swap controllers should always be considered. When the TPS25910 interrupts current flow, input inductance generates a positive voltage spike on the input and output inductance generates a negative voltage spike on the output. Such transients can easily exceed twice the supply voltage if steps are not taken to address the issue. Typical methods for addressing transients include;

- Minimizing lead length/inductance into and out of the device.
- Transient Voltage Suppressors (TVS) on the input to absorb inductive spikes.
- Shottky diode across the output to absorb negative spikes.
- A combination of ceramic and electrolytic capacitors on the input and output to absorb energy.

The following equation estimates the magnitude of these voltage spikes:

Where;

$$V_{\text{SPIKE(absolute)}} = V_{\text{NOM}} + I_{\text{LOAD}} \times \sqrt{\frac{L}{C}} \quad (14)$$

- V_{NOM} equals the nominal supply voltage.
- I_{LOAD} equals the load current.
- C equals the capacitance present at the input or output of the TPS25910.
- L equals the effective inductance seen looking into the source or the load.

The inductance due to a straight length of wire equals approximately.



Where;

$$L_{\text{straightwire}} \approx 0.2 \times L \times \ln\left(\frac{4 \times L}{D} - 0.75\right) \text{ (nH)} \quad (15)$$

- L equals the length of the wire.
- D equals wire diameter.

Some applications may require the addition of a TVS to prevent transients from exceeding the absolute ratings if sufficient capacitance cannot be included.

PACKAGING INFORMATION

Orderable Device	Status (1)	Package Type	Package Drawing	Pins	Package Qty	Eco Plan (2)	Lead finish/ Ball material (6)	MSL Peak Temp (3)	Op Temp (°C)	Device Marking (4/5)	Samples
TPS25910RSAR	ACTIVE	QFN	RSA	16	3000	RoHS & Green	NIPDAU	Level-2-260C-1 YEAR	-40 to 125	TPS 25910	
TPS25910RSAT	ACTIVE	QFN	RSA	16	250	RoHS & Green	NIPDAU	Level-2-260C-1 YEAR	-40 to 125	TPS 25910	

(1) The marketing status values are defined as follows:

ACTIVE: Product device recommended for new designs.

LIFEBUY: TI has announced that the device will be discontinued, and a lifetime-buy period is in effect.

NRND: Not recommended for new designs. Device is in production to support existing customers, but TI does not recommend using this part in a new design.

PREVIEW: Device has been announced but is not in production. Samples may or may not be available.

OBSOLETE: TI has discontinued the production of the device.

(2) **RoHS:** TI defines "RoHS" to mean semiconductor products that are compliant with the current EU RoHS requirements for all 10 RoHS substances, including the requirement that RoHS substance do not exceed 0.1% by weight in homogeneous materials. Where designed to be soldered at high temperatures, "RoHS" products are suitable for use in specified lead-free processes. TI may reference these types of products as "Pb-Free".

RoHS Exempt: TI defines "RoHS Exempt" to mean products that contain lead but are compliant with EU RoHS pursuant to a specific EU RoHS exemption.

Green: TI defines "Green" to mean the content of Chlorine (Cl) and Bromine (Br) based flame retardants meet JS709B low halogen requirements of <=1000ppm threshold. Antimony trioxide based flame retardants must also meet the <=1000ppm threshold requirement.

(3) MSL, Peak Temp. - The Moisture Sensitivity Level rating according to the JEDEC industry standard classifications, and peak solder temperature.

(4) There may be additional marking, which relates to the logo, the lot trace code information, or the environmental category on the device.

(5) Multiple Device Markings will be inside parentheses. Only one Device Marking contained in parentheses and separated by a "~" will appear on a device. If a line is indented then it is a continuation of the previous line and the two combined represent the entire Device Marking for that device.

(6) Lead finish/Ball material - Orderable Devices may have multiple material finish options. Finish options are separated by a vertical ruled line. Lead finish/Ball material values may wrap to two lines if the finish value exceeds the maximum column width.

Important Information and Disclaimer:The information provided on this page represents TI's knowledge and belief as of the date that it is provided. TI bases its knowledge and belief on information provided by third parties, and makes no representation or warranty as to the accuracy of such information. Efforts are underway to better integrate information from third parties. TI has taken and continues to take reasonable steps to provide representative and accurate information but may not have conducted destructive testing or chemical analysis on incoming materials and chemicals. TI and TI suppliers consider certain information to be proprietary, and thus CAS numbers and other limited information may not be available for release.

In no event shall TI's liability arising out of such information exceed the total purchase price of the TI part(s) at issue in this document sold by TI to Customer on an annual basis.

TAPE AND REEL INFORMATION

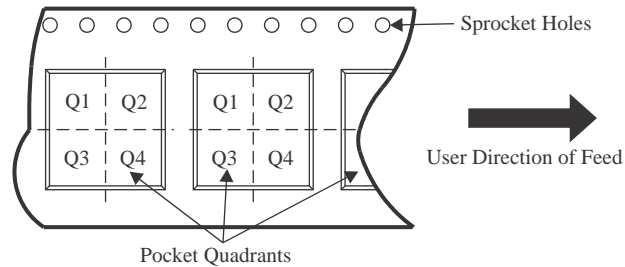
QUADRANT ASSIGNMENTS FOR PIN 1 ORIENTATION IN TAPE

*All dimensions are nominal

Device	Package Type	Package Drawing	Pins	SPQ	Reel Diameter (mm)	Reel Width W1 (mm)	A0 (mm)	B0 (mm)	K0 (mm)	P1 (mm)	W (mm)	Pin1 Quadrant
TPS25910RSAR	QFN	RSA	16	3000	330.0	12.4	4.25	4.25	1.15	8.0	12.0	Q2
TPS25910RSAT	QFN	RSA	16	250	180.0	12.4	4.25	4.25	1.15	8.0	12.0	Q2

TAPE AND REEL BOX DIMENSIONS

*All dimensions are nominal

Device	Package Type	Package Drawing	Pins	SPQ	Length (mm)	Width (mm)	Height (mm)
TPS25910RSAR	QFN	RSA	16	3000	367.0	367.0	35.0
TPS25910RSAT	QFN	RSA	16	250	210.0	185.0	35.0

RSA (S-PVQFN-N16)

PLASTIC QUAD FLATPACK NO-LEAD

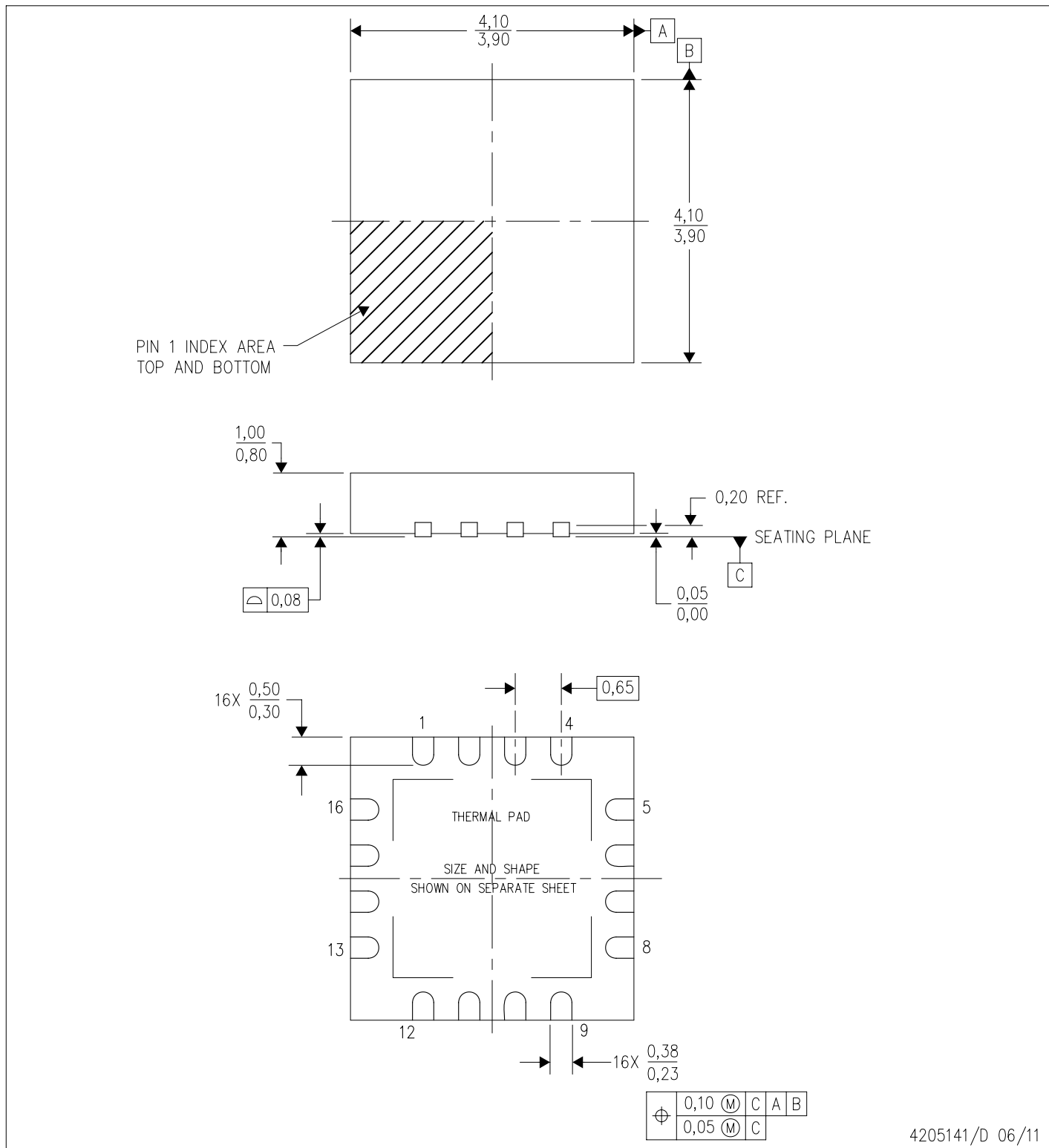

4205141/D 06/11

- NOTES:
- All linear dimensions are in millimeters. Dimensioning and tolerancing per ASME Y14.5M-1994.
 - This drawing is subject to change without notice.
 - Quad Flatpack, No-leads (QFN) package configuration.
 - The package thermal pad must be soldered to the board for thermal and mechanical performance.
 - See the additional figure in the Product Data Sheet for details regarding the exposed thermal pad features and dimensions.
 - Falls within JEDEC MO-220.

重要声明和免责声明

TI“按原样”提供技术和可靠性数据（包括数据表）、设计资源（包括参考设计）、应用或其他设计建议、网络工具、安全信息和其他资源，不保证没有瑕疵且不做任何明示或暗示的担保，包括但不限于对适销性、某特定用途方面的适用性或不侵犯任何第三方知识产权的暗示担保。

这些资源可供使用 TI 产品进行设计的熟练开发人员使用。您将自行承担以下全部责任：(1) 针对您的应用选择合适的 TI 产品，(2) 设计、验证并测试您的应用，(3) 确保您的应用满足相应标准以及任何其他功能安全、信息安全、监管或其他要求。

这些资源如有变更，恕不另行通知。TI 授权您仅可将这些资源用于研发本资源所述的 TI 产品的应用。严禁对这些资源进行其他复制或展示。您无权使用任何其他 TI 知识产权或任何第三方知识产权。您应全额赔偿因在这些资源的使用中对 TI 及其代表造成的任何索赔、损害、成本、损失和债务，TI 对此概不负责。

TI 提供的产品受 [TI 的销售条款](#) 或 [ti.com](#) 上其他适用条款/TI 产品随附的其他适用条款的约束。TI 提供这些资源并不会扩展或以其他方式更改 TI 针对 TI 产品发布的适用的担保或担保免责声明。

TI 反对并拒绝您可能提出的任何其他或不同的条款。

邮寄地址：Texas Instruments, Post Office Box 655303, Dallas, Texas 75265

Copyright © 2023，德州仪器 (TI) 公司

X-ON Electronics

Largest Supplier of Electrical and Electronic Components

Click to view similar products for [Hot Swap Voltage Controllers](#) category:

Click to view products by [Texas Instruments](#) manufacturer:

Other Similar products are found below :

[LT4256-1CS8#TRPBF](#) [HIP1011BCBZA](#) [ISL6119HIBZA](#) [ISL6141IBZA](#) [ISL6151CBZA-T](#) [ISL61851ACBZ](#) [ISL61851BCBZ](#)
[ISL61851BIBZ-T](#) [ISL61851CCBZ](#) [ISL61851DCBZ](#) [ISL61851GCBZ](#) [ISL61851HCBZ](#) [ISL61851ICBZ](#) [ISL61851KCBZ](#) [TPS25961DRVR](#)
[TPS26612DDFR](#) [LM74700MDDFREP](#) [TPS23880RTQR](#) [MP5991GLU-Z](#) [MP5048GU-Z](#) [TPS259822LNRGER](#) [TPS259461ARPWR](#)
[TPS16530RGER](#) [LT4256-3IGN#TRPBF](#) [LT1641IS8#TRPBF](#) [LTC4218IGN#TRPBF](#) [LTC4210-1CS6#TRPBF](#) [LTC4211IMS8#TRPBF](#)
[RT1720GF](#) [TPS259827ONRGER](#) [LM74502HDDFR](#) [TPS259823ONRGER](#) [LM74502QDDFRQ1](#) [LM5068MMX-2/NOPB](#)
[LM74502HQDDFRQ1](#) [TPS25210LRPWR](#) [TPS26601RHFR](#) [TPS26611DDFR](#) [TPS259472ARPWR](#) [LM74500QDDFRQ1](#) [TPS26610DDFR](#)
[TPS259460ARPWR](#) [LM5066IPMHX/NOPB](#) [TPS259824LNRGER](#) [TPS259823LNRGER](#) [NU6-II 60kA/385V 4P](#) [NU6-G 40kA/275V 4P](#)
[NU6-II 40kA/385V 2P](#) [TPS26635RGER](#) [AL6-NFNFBW-9](#)