

TPS2663x 60V 6A 功率限制浪涌保护工业电子保险丝

1 特性

- 工作电压为 4.5V 至 60V，绝对最大值为 67V
- 集成式 60V、31mΩ R_{ON} 热插拔 FET
- 通过外部 N 沟道 FET 提供反极性保护和反向电流阻断支持
- 可调电流限制为 0.6A 至 6A (± 7%)
- 浪涌期间具有电气快速瞬变 (IEC61000-4-4) 抗扰性和负载保护 (IEC 61000-4-5) 并提供 A 类系统性能
- 快速反向电流阻断 (0.17μs)
- 具有可调节输出功率限制功能 (± 6%) 的型号
- 可调节 UVLO、OVP 切断、输出压摆率控制，用于浪涌电流限制
- 通过在器件加电期间进行热调节，为大型及未知容性负载充电
- 具有最大 35V 和 39V 过压钳位的型号
- 电源正常输出 (PGOOD)
- 可选过流故障响应选项 (自动重试和闭锁模式)
- 具有 2x 脉冲过流支持的型号
- 模拟电流监控器 (IMON) 输出 (± 6%)
- 通过 UL 2367 认证
 - 文件编号 E169910
 - RILIM ≥ 3kΩ
- 通过 IEC 62368-1 认证

2 应用

- 工厂自动化和控制 - PLC、DCS、HMI、I/O 模块、传感器集线器
- 电机驱动器 - CNC、编码器电源
- 电子断路器

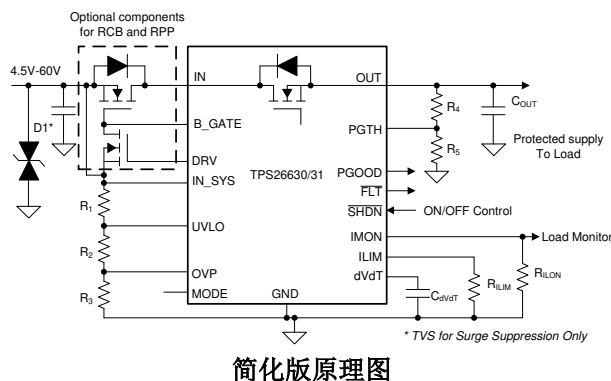

3 说明

TPS2663x 器件是易于使用的正极 60V 和 6A 电子保险丝，其中包含一个 31mΩ 的集成式 FET。该器件具有一个 B-FET 驱动器，用于在需要输入反极性故障和反向电流阻断保护的系统中控制外部 N 沟道 FET。该器件集成了强大的保护功能，可简化在 IEC61000-4-5 工业浪涌测试等系统测试期间需要保护的系统设计。该器件具有可调节输出功率限制 (PLIM) 功能，从而简化需要符合 IEC61010-1 和 UL1310 等标准的系统设计。其他保护功能包括可调节过流保护、快速短路保护、输出压摆率控制、过压保护和欠压锁定。

为实现系统状态监视和下游负载控制，该器件提供了故障和精确的电流监视器输出。可以使用 PGOOD 来启用和禁用下游直流/直流转换器控制。MODE 引脚可用于在两种限流故障响应 (闭锁和自动重试) 之间灵活地对器件进行配置。

器件信息⁽¹⁾

| 器件型号 | 封装 | 封装尺寸 (标称值) |
|--|-------------|-----------------|
| TPS26630 TPS26631 TPS26632 TPS26633 TPS26635 | VQFN (24) | 4.00mm × 4.00mm |
| TPS26631 TPS26633 TPS26636 | HTSSOP (20) | 6.50mm x 4.40mm |

- (1) 如需了解所有可用封装，请参阅数据表末尾的可订购产品附录。

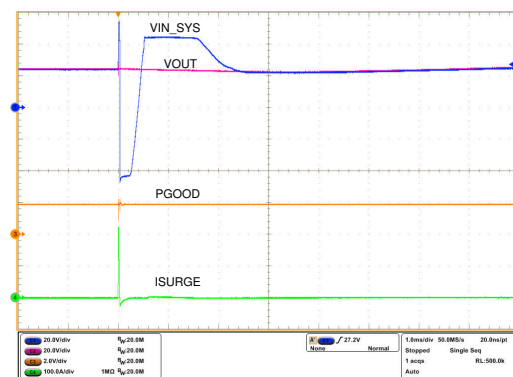

24V 电源下的 IEC61000-4-5 浪涌性能



Table of Contents

| | | | |
|--|----|---|----|
| 1 特性 | 1 | 10 Application and Implementation | 30 |
| 2 应用 | 1 | 10.1 Application Information..... | 30 |
| 3 说明 | 1 | 10.2 Typical Application: Power Path Protection in a PLC System..... | 30 |
| 4 Revision History | 2 | 10.3 System Examples..... | 35 |
| 5 Device Comparison Table | 3 | 10.4 Do's and Don'ts..... | 37 |
| 6 Pin Configuration and Functions | 3 | 11 Power Supply Recommendations | 37 |
| 7 Specifications | 6 | 11.1 Transient Protection..... | 37 |
| 7.1 Absolute Maximum Ratings..... | 6 | 12 Layout | 39 |
| 7.2 ESD Ratings..... | 6 | 12.1 Layout Guidelines..... | 39 |
| 7.3 Recommended Operating Conditions..... | 6 | 12.2 Layout Example..... | 40 |
| 7.4 Thermal Information..... | 7 | 13 Device and Documentation Support | 42 |
| 7.5 Electrical Characteristics..... | 7 | 13.1 Documentation Support..... | 42 |
| 7.6 Timing Requirements..... | 9 | 13.2 接收文档更新通知..... | 42 |
| 7.7 Typical Characteristics..... | 11 | 13.3 支持资源..... | 42 |
| 8 Parameter Measurement Information | 14 | 13.4 Trademarks..... | 42 |
| 9 Detailed Description | 16 | 13.5 Electrostatic Discharge Caution..... | 42 |
| 9.1 Overview..... | 16 | 13.6 术语表..... | 42 |
| 9.2 Functional Block Diagram..... | 17 | 14 Mechanical, Packaging, and Orderable Information | 42 |
| 9.3 Feature Description..... | 18 | | |
| 9.4 Device Functional Modes..... | 29 | | |

4 Revision History

注：以前版本的页码可能与当前版本的页码不同

| | |
|--|-------------|
| Changes from Revision E (March 2020) to Revision F (June 2021) | Page |
| • 更新了整个文档中的表格、图和交叉参考的编号格式..... | 1 |
| Changes from Revision D (August 2019) to Revision E (March 2020) | Page |
| • 将 UL 2367 从“认证正在处理中”更改为“已认证”..... | 1 |
| • 向 特性 部分添加了“通过 IEC 62368-1 认证”..... | 1 |
| Changes from Revision C (March 2019) to Revision D (August 2019) | Page |
| • 将 器件信息表 中的 TPS26632 器件替换为 TPS26636 器件..... | 1 |
| • Added the TPS26636 device to the <i>Pin Configuration and Functions</i> table..... | 3 |
| • Added the TPS26636 device to the <i>Pin Functions</i> table..... | 3 |
| • Updated the Input Voltage in the <i>Absolute Maximum Ratings</i> table..... | 6 |
| • Updated the PLIM Input and Output Ramp Control in the <i>Electrical Characteristics</i> table..... | 7 |
| Changes from Revision B (January 2019) to Revision C (March 2019) | Page |
| • 将“预告信息”更改为“量产数据”..... | 1 |
| Changes from Revision A (December 2018) to Revision B (January 2019) | Page |
| • Updated the <i>Pin Configuration and Functions</i> section..... | 3 |
| • Updated Layout Example | 40 |
| Changes from Revision * (September 2018) to Revision A (December 2018) | Page |
| • Updated the <i>Pin Configuration and Functions</i> section..... | 3 |
| • Updated Functional Block Diagram | 17 |
| • Updated Layout Example | 40 |

5 Device Comparison Table

| PART NUMBER | OVERVOLTAGE PROTECTION | OVERLOAD FAULT RESPONSE | ADJUSTABLE OUTPUT POWER LIMITING |
|-------------|-------------------------------------|---|----------------------------------|
| TPS26630 | Overvoltage cut-off, adjustable | Active Current Limiting (1x) | No |
| TPS26631 | Overvoltage cut-off, adjustable | Active Current Limiting with Pulse current support (2x) | No |
| TPS26632 | Overvoltage clamp, fixed (35-V max) | Active Current Limiting (1x) | Yes |
| TPS26633 | Overvoltage clamp, fixed (35-V max) | Active Current Limiting with Pulse current support (2x) | Yes |
| TPS26635 | Overvoltage clamp, fixed (39-V max) | Active Current Limiting with Pulse current support (2x) | Yes |
| TPS26636 | Overvoltage clamp, fixed (35-V max) | Active Current Limiting with Pulse current support (2x) | Yes |

6 Pin Configuration and Functions



图 6-1. TPS26630, TPS26631 RGE Package 24-Pin VQFN Top View



图 6-3. TPS26632, TPS26633, TPS26635 RGE Package 24-Pin VQFN Top View

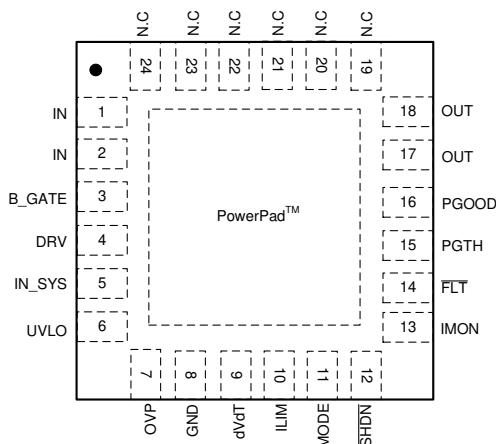

图 6-2. TPS26631 PWP Package 20-Pin HTSSOP Top View

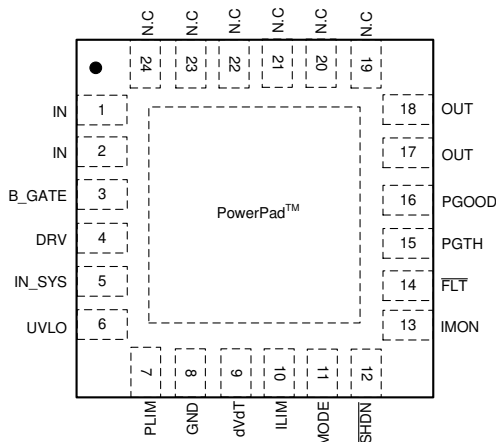

图 6-4. TPS26633, TPS26636 PWP Package 20-Pin HTSSOP Top View

表 6-1. Pin Configuration and Functions

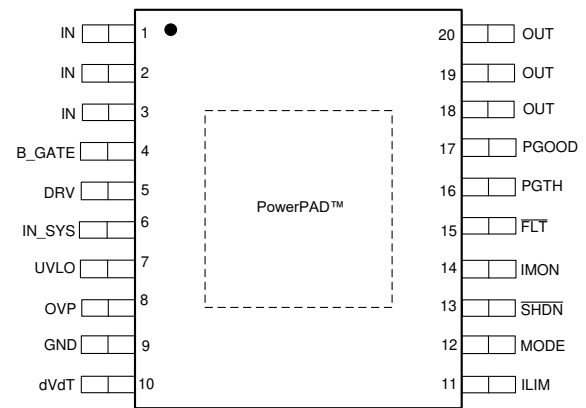
| NAME | PIN | | TYPE | DESCRIPTION |
|--------|--|--------|------|---|
| | TPS26630, TPS26631, TPS26632, TPS26633, TPS26635, TPS26636 | | | |
| | VQFN | HTSSOP | | |
| IN | 1 | 1 | P | Power input. Connects to the DRAIN of the internal FET |
| | 2 | 2 | | |
| | — | 3 | | |
| B_GATE | 3 | 4 | O | Blocking FET gate driver output. Connect B_GATE to GATE of the external NFET. If external FET is not used then leave B_GATE pin floating. See the Input Reverse Polarity Protection (B_GATE, DRV) section. |
| DRV | 4 | 5 | O | Blocking FET fast pull down switch drive. Connect DRV to the GATE of external pull down switch. Leave this pin floating if external N-FET is not used. |
| IN_SYS | 5 | 6 | P | Power input and supply voltage of the device. When an external Blocking FET is used then connect IN_SYS to source of the FET. Short IN_SYS to IN in case blocking FET is not used. |
| UVLO | 6 | 7 | I | Input for setting the programmable undervoltage lockout threshold. An undervoltage event turns off the internal FET and asserts FLT to indicate the power-failure. Connect UVLO pin to GND pin to select the internal default threshold. |
| OVP | 7 | 8 | I | Input for setting the programmable overvoltage protection threshold (For TPS26630 and TPS26631 Only). An overvoltage event turns off the internal FET and asserts FLT to indicate the overvoltage fault. Connect OVP pin to GND pin externally to select the internal default threshold. |
| PLIM | 7 | 8 | I | Input for setting the programmable output power limiting threshold (For TPS26632, TPS26633, TPS26635 and TPS26636 Only). Connect a resistor across PLIM to GND to set the output power limit. Connect PLIM to GND if PLIM feature is not used. See the tput power limit. Connect PLIM to GND if PLIM feature is not used. See the Output Power Limiting, PLIM (TPS26632, TPS26633, TPS26635 and TPS26636 Only) section. |
| GND | 8 | 9 | — | Connect GND to system ground |
| dVdT | 9 | 10 | I/O | A capacitor from this pin to GND sets output voltage slew rate. See the Hot Plug-In and In-Rush Current Control section. |
| ILIM | 10 | 11 | I/O | A resistor from this pin to GND sets the overload and short-circuit current limit. See the Overload and Short Circuit Protection section. |
| MODE | 11 | 12 | I | Mode selection pin for overload fault response. See the Device Functional Modes section. |
| SHDN | 12 | 13 | I | Shutdown pin. Pulling SHDN low makes the device to enter into low power shutdown mode. Cycling SHDN pin voltage resets the device that has latched off due to a fault condition. |
| IMON | 13 | 14 | O | Analog current monitor output. This pin sources a scaled down ratio of current through the internal FET. A resistor from this pin to GND converts current to proportional voltage. If unused, leave it floating. |
| FLT | 14 | 15 | O | Fault event indicator. It is an open drain output. If unused, leave floating or connect to GND. |
| PGTH | 15 | 16 | I | PGOOD comparator input. |
| PGOOD | 16 | 17 | O | Active High. A high indicates PGTH has crossed the $V_{(PGTHR)}$ threshold and the internal FET is enhanced. PGOOD goes low when $V_{(PGTH)}$ hits $V_{(PGTF)}$ threshold. If PGOOD is unused then connect to GND or leave it floating. |
| OUT | 17 | 18 | P | Power output of the device |
| | 18 | 19 | | |
| | — | 20 | | |

表 6-1. Pin Configuration and Functions (continued)

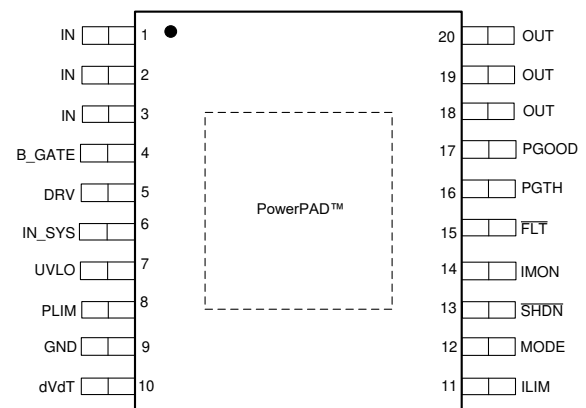
| NAME | PIN | | TYPE | DESCRIPTION |
|-----------|--|--------|------|---|
| | TPS26630, TPS26631, TPS26632, TPS26633, TPS26635, TPS26636 | | | |
| | VQFN | HTSSOP | | |
| N. C | 19 | — | — | No Connect |
| | 20 | | | |
| | 21 | | | |
| | 22 | | | |
| | 23 | | | |
| | 24 | | | |
| PowerPad™ | — | — | — | Connect PowerPad to GND plane for heat sinking. Do not use PowerPad as the only electrical connection to GND. |

7 Specifications

7.1 Absolute Maximum Ratings

over operating free-air temperature range (unless otherwise noted)⁽¹⁾

| | | MIN | MAX | UNIT |
|---|--------------------------------|--------------------|--------------------|------|
| IN_SYS | Input Voltage | - 60 | 67 | V |
| IN_SYS (10ms transient), T _A = 25 °C | | - 60 | 75 | V |
| IN, OUT, UVLO, FLT, PGOOD, PGTH | | - 0.3 | 67 | V |
| IN_SYS - OUT (10ms transient), with a Blocking FET | | - 85 | | V |
| IN (10ms transient), T _A = 25 °C | | - 0.3 | 75 | V |
| BGATE | | - 60 | 81 | V |
| BGATE - IN_SYS | | - 0.3 | 14 | V |
| DRV | | - 60 | 72 | V |
| DRV - IN_SYS | | - 0.3 | 20 | V |
| OVP, dVdT, IMON, MODE, SHDN, ILIM, PLIM | | - 0.3 | 5.5 | V |
| I _{FLT} , I _{dVdT} , I _{PGOOD} | | Sink current | | 10 |
| I _{dVdT} , I _{ILIM} , I _{PLIM} , I _{MODE} , I _{SHDN} | Source current | Internally limited | | |
| T _J | Operating Junction temperature | - 40 | 150 | °C |
| | Transient junction temperature | - 65 | T _(TSD) | |
| T _{stg} | Storage temperature | - 65 | 150 | |

- (1) Stresses beyond those listed under *Absolute Maximum Rating* may cause permanent damage to the device. These are stress ratings only, which do not imply functional operation of the device at these or any other conditions beyond those indicated under *Recommended Operating Condition*. Exposure to absolute-maximum-rated conditions for extended periods may affect device reliability.

7.2 ESD Ratings

| | | | VALUE | UNIT |
|--------------------|-------------------------|--|-------|------|
| V _(ESD) | Electrostatic discharge | Human body model (HBM), per ANSI/ESDA/ JEDEC JS-001, all pins ⁽¹⁾ | ±2000 | V |
| | | Charged device model (CDM), per JEDEC specification JESD22-C101, all pins ⁽²⁾ | ±1000 | |

- (1) JEDEC document JEP155 states that 500-V HBM allows safe manufacturing with a standard ESD control process.
(2) JEDEC document JEP157 states that 250-V CDM allows safe manufacturing with a standard ESD control process.

7.3 Recommended Operating Conditions

over operating free-air temperature range (unless otherwise noted)

| | | MIN | NOM | MAX | UNIT |
|-----------------------------|----------------------|------|-----|-----|------|
| IN_SYS, IN | Input Voltage | 4.5 | | 60 | V |
| OUT, UVLO, PGTH, PGOOD, FLT | | 0 | | 60 | |
| OVP, dVdT, IMON, MODE | | 0 | | 4 | |
| SHDN | | 0 | | 5 | |
| ILIM | Resistance | 3 | | 30 | kΩ |
| IMON | Resistance | 1 | | | |
| PLIM | Resistance | 60.4 | | 150 | |
| IN, IN_SYS, OUT | External Capacitance | 0.1 | | | μF |
| dVdT | | 10 | | | nF |

over operating free-air temperature range (unless otherwise noted)

| | | MIN | NOM | MAX | UNIT |
|-------|--------------------------------|------|-----|-----|------|
| T_J | Operating Junction temperature | - 40 | 25 | 125 | °C |

7.4 Thermal Information

| THERMAL METRIC ⁽¹⁾ | | TPS2663 | | UNIT |
|-------------------------------|--|------------|--------------|------|
| | | RGE (VSON) | PWP (HTSSOP) | |
| | | 24 PINS | 20 PINS | |
| $R_{\theta JA}$ | Junction-to-ambient thermal resistance | 31.4 | 32.2 | °C/W |
| $R_{\theta JC(top)}$ | Junction-to-case (top) thermal resistance | 23.2 | 23.4 | °C/W |
| $R_{\theta JB}$ | Junction-to-board thermal resistance | 10.2 | 10 | °C/W |
| Ψ_{JT} | Junction-to-top characterization parameter | 0.3 | 0.3 | °C/W |
| Ψ_{JB} | Junction-to-board characterization parameter | 10.2 | 9.9 | °C/W |
| $R_{\theta JC(bot)}$ | Junction-to-case (bottom) thermal resistance | 2.8 | 3.6 | °C/W |

(1) For more information about traditional and new thermal metrics, see the [Semiconductor and IC Package Thermal Metrics](#) application report.

7.5 Electrical Characteristics

- 40°C ≤ $T_A = T_J$ ≤ +125°C, 4.5 V < $V_{(IN_SYS)} = V_{(IN)}$ < 60 V, $V_{(SHDN)} = 2$ V, $R_{(ILIM)} = 30$ kΩ, $IMON = PGOOD = \overline{FLT} = OPEN$, $C_{(OUT)} = 1$ μF, $C_{(dVdT)} = OPEN$. (All voltages referenced to GND, (unless otherwise noted))

| PARAMETER | | TEST CONDITIONS | MIN | TYP | MAX | UNIT |
|---|--|---|-------|-------|-------|------|
| SUPPLY VOLTAGE | | | | | | |
| $V_{(IN_SYS)}$ | Operating input voltage | | 4.5 | | 60 | V |
| $I_{Q(ON)}$ | Supply current | Enabled: $V_{(SHDN)} = 2$ V | | 1.38 | 1.7 | mA |
| $I_{Q(OFF)}$ | | $V_{(SHDN)} = 0$ V | | 21 | 60 | μA |
| $I_{(GND)}$ | Ground current during reverse polarity | $V_{(IN_SYS)} = -24$ V, $V_{(IN)}$ = Floating, $V_{(OUT)} = 0$ V | | 144 | 200 | μA |
| $V_{(OVC)}$ | Over voltage clamp | TPS26632, TPS26633, TPS26636 Only, $V_{(IN_SYS)} > 35$ V, $I_{(OUT)} = 1$ mA | 32 | 32.8 | 35 | V |
| | | TPS26635 Only, $V_{(IN_SYS)} > 40$ V, $I_{(OUT)} = 1$ mA | 35.7 | 36.6 | 39 | V |
| UNDERVOLTAGE LOCKOUT (UVLO) INPUT | | | | | | |
| $V_{(INSYS_UVLO)}$ | Factory set $V_{(IN_SYS)}$ undervoltage trip level trip level | $V_{(IN_SYS)}$ rising, $V_{(UVLO)} = 0$ V | 15.1 | 15.46 | 15.9 | V |
| | | $V_{(IN_SYS)}$ falling, $V_{(UVLO)} = 0$ V | 14 | 14.47 | 15.1 | V |
| $V_{(SEL_UVLO)}$ | Internal UVLO select threshold | | 180 | 210 | 240 | mV |
| $V_{(UVLOR)}$ | UVLO threshold voltage, rising | | 1.176 | 1.2 | 1.224 | V |
| $V_{(UVLOF)}$ | UVLO threshold voltage, falling | | 1.09 | 1.122 | 1.15 | V |
| $I_{(UVLO)}$ | UVLO Input leakage current | 0 V ≤ $V_{(UVLO)}$ ≤ 60 V | - 150 | 8 | 150 | nA |
| OVERVOLTAGE PROTECTION (OVP) INPUT | | | | | | |
| $V_{(IN_SYS_OVP)}$ | Factory set $V_{(IN_SYS)}$ overvoltage trip level trip level | $V_{(IN_SYS)}$ rising, $V_{(OVP)} = 0$ V | 33.2 | 34.33 | 35.4 | V |
| | | $V_{(IN_SYS)}$ falling, $V_{(OVP)} = 0$ V | 32.7 | 33.89 | 35 | V |
| $V_{(SEL_OVP)}$ | Internal OVP select threshold | | 180 | 210 | 240 | mV |
| $V_{(OVPR)}$ | over-voltage threshold voltage, rising | | 1.176 | 1.2 | 1.224 | V |
| $V_{(OVPF)}$ | over-voltage threshold voltage, falling | | 1.09 | 1.122 | 1.15 | V |
| $I_{(OVP)}$ | OVP Input leakage current | 0 V ≤ $V_{(OVP)}$ ≤ 4 V | - 150 | 0 | 150 | nA |
| CURRENT LIMIT PROGRAMMING (ILIM) | | | | | | |

7.5 Electrical Characteristics (continued)

$-40^{\circ}\text{C} \leq T_A = T_J \leq +125^{\circ}\text{C}$, $4.5\text{ V} < V_{(\text{IN_SYS})} = V_{(\text{IN})} < 60\text{ V}$, $V_{(\text{SHDN})} = 2\text{ V}$, $R_{(\text{ILIM})} = 30\text{ k}\Omega$, $\text{IMON} = \text{PGOOD} = \overline{\text{FLT}} = \text{OPEN}$, $C_{(\text{OUT})} = 1\ \mu\text{F}$, $C_{(\text{dVdT})} = \text{OPEN}$. (All voltages referenced to GND, (unless otherwise noted))

| PARAMETER | | TEST CONDITIONS | MIN | TYP | MAX | UNIT |
|--|--|--|----------------------------|-------|-------|------------------|
| $I_{(\text{OL})}$ | Over Load current limit | $R_{(\text{ILIM})} = 30\text{ k}\Omega$, $V_{(\text{IN})} - V_{(\text{OUT})} = 1\text{ V}$ | 0.54 | 0.6 | 0.66 | A |
| | | $R_{(\text{ILIM})} = 9\text{ k}\Omega$, $V_{(\text{IN})} - V_{(\text{OUT})} = 1\text{ V}$ | 1.84 | 2 | 2.16 | A |
| | | $R_{(\text{ILIM})} = 4.02\text{ k}\Omega$, $V_{(\text{IN})} - V_{(\text{OUT})} = 1\text{ V}$ | 4.185 | 4.5 | 4.815 | A |
| | | $R_{(\text{ILIM})} = 3\text{ k}\Omega$, $V_{(\text{IN})} - V_{(\text{OUT})} = 1\text{ V}$ | 5.58 | 6 | 6.42 | A |
| $I_{(\text{OL_Pulse})}$ | Transient Pulse Over current limit | $3\text{ k}\Omega < R_{(\text{ILIM})} < 30\text{ k}\Omega$, TPS26631, TPS26633, TPS26635 and TPS26636 Only | $2 \times I_{(\text{OL})}$ | | | A |
| $I_{(\text{FASTRIP})}$ | Fast-trip comparator threshold | TPS26630 and TPS26632 Only | $2 \times I_{(\text{OL})}$ | | | A |
| $I_{(\text{FASTRIP})}$ | Fast-trip comparator threshold | TPS26631, TPS26633, TPS26635 and TPS26636 Only | $3 \times I_{(\text{OL})}$ | | | A |
| $I_{(\text{SCP})}$ | Short Circuit Protect current | | 45 | | | A |
| OUTPUT POWER LIMITING CONTROL (PLIM) INPUT - TPS26632, TPS26633, TPS26635 and TPS26636 ONLY | | | | | | |
| $V_{(\text{SEL_PLIM})}$ | Power Limit Feature select threshold | | 160 | 217 | 240 | mV |
| $I_{(\text{PLIM})}$ | PLIM sourcing current | $V_{(\text{PLIM})} = 0\text{ V}$ | 4.4 | 5.02 | 5.6 | μA |
| $P_{(\text{PLIM})}$ | Max Output power | $R_{(\text{PLIM})} = 100\text{ k}\Omega$ | 94 | 100 | 106 | W |
| | | $R_{(\text{PLIM})} = 150\text{ k}\Omega$ ⁽¹⁾ | 141.9 | 151 | 160.1 | W |
| B_GATE (BLOCKING FET GATE DRIVER) | | | | | | |
| $V_{(\text{B_GATE})}$ | B_GATE clamp voltage | $V_{(\text{B_GATE})} - V_{(\text{IN_SYS})}$ | 8.3 | 10.23 | 14 | V |
| $I_{(\text{B_GATE})}$ | Blocking FET Gate drive current | $V_{(\text{B_GATE})} - V_{(\text{IN_SYS})} = 1\text{ V}$ | 16 | 19.4 | 23 | μA |
| $R_{\text{pd_BGATE}}$ | B_GATE Pull down resistance | | 800 | 1010 | 1200 | $\text{k}\Omega$ |
| $V_{(\text{DRV_OH})}$ | DRV logic high level | $V_{(\text{DRV})} - V_{(\text{IN_SYS})}$, $C_{(\text{DRV})} \leq 50\text{ pF}$ | 3 | 4.25 | 5.2 | V |
| PASS FET OUTPUT (OUT) | | | | | | |
| R_{ON} | IN to OUT total ON resistance | $0.6\text{ A} \leq I_{(\text{OUT})} \leq 6\text{ A}$, $T_J = 25^{\circ}\text{C}$ | 26 | 30.44 | 34.5 | $\text{m}\Omega$ |
| R_{ON} | IN to OUT total ON resistance | $0.6\text{ A} \leq I_{(\text{OUT})} \leq 6\text{ A}$, $T_J = 85^{\circ}\text{C}$ | 33 | | 45 | $\text{m}\Omega$ |
| R_{ON} | IN to OUT total ON resistance | $0.6\text{ A} \leq I_{(\text{OUT})} \leq 6\text{ A}$, $-40^{\circ}\text{C} \leq T_J \leq +125^{\circ}\text{C}$ | 19 | 30.44 | 53 | $\text{m}\Omega$ |
| $I_{\text{kg}(\text{OUT})}$ | OUT leakage during input supply brownout | $V_{(\text{IN_SYS})} = 0\text{ V}$, $V_{(\text{OUT})} = 24\text{ V}$, $V_{(\text{IN})} = \text{Floating}$, $V_{(\text{SHDN})} = 2\text{V}$, Sinking | - 100 | | | μA |
| $V_{(\text{REVTH})}$ | $V_{(\text{IN_SYS})} - V_{(\text{OUT})}$ threshold for reverse protection comparator, rising | | - 20 | - 15 | - 9 | mV |
| $V_{(\text{FWDTH})}$ | $V_{(\text{IN_SYS})} - V_{(\text{OUT})}$ threshold for reverse protection comparator, falling | | 45 | 57 | 67 | mV |
| OUTPUT RAMP CONTROL (dVdT) | | | | | | |
| $I_{(\text{dVdT})}$ | dVdT charging current | $V_{(\text{dVdT})} = 0\text{ V}$ | 1.775 | 2 | 2.225 | μA |
| $\text{GAIN}_{(\text{dVdT})}$ | dVdT to OUT gain | $V_{(\text{OUT})} / V_{(\text{dVdT})}$ | 23.5 | 25 | 26 | V/V |
| $V_{(\text{dVdTmax})}$ | dVdT maximum capacitor voltage | | 3.8 | 4.17 | 4.75 | V |
| $R_{(\text{dVdT})}$ | dVdT discharging resistance | | 10 | 16.6 | 26.6 | Ω |
| LOW IQ SHUTDOWN (SHDN) INPUT | | | | | | |
| $V_{(\text{SHDN})}$ | Open circuit voltage | $I_{(\text{SHDN})} = 0.1\ \mu\text{A}$ | 2.48 | 2.7 | 3.3 | V |
| $V_{(\text{SHUTF})}$ | SHDN threshold voltage for low IQ shutdown, falling | | 0.8 | | | V |
| $V_{(\text{SHUTR})}$ | SHDN threshold rising | | 2 | | | V |
| $I_{(\text{SHDN})}$ | Leakage current | $V_{(\text{SHDN})} = 0\text{ V}$ | - 10 | | | μA |
| CURRENT MONITOR OUTPUT (IMON) | | | | | | |
| $\text{GAIN}_{(\text{IMON})}$ | Gain factor $I_{(\text{IMON})} : I_{(\text{OUT})}$ | $0.6\text{ A} \leq I_{(\text{OUT})} \leq 2\text{ A}$ | 25.66 | 27.9 | 30.14 | $\mu\text{A/A}$ |

7.5 Electrical Characteristics (continued)

$-40^{\circ}\text{C} \leq T_A = T_J \leq +125^{\circ}\text{C}$, $4.5\text{ V} < V_{(\text{IN_SYS})} = V_{(\text{IN})} < 60\text{ V}$, $V_{(\text{SHDN})} = 2\text{ V}$, $R_{(\text{ILIM})} = 30\text{ k}\Omega$, $\text{IMON} = \text{PGOOD} = \overline{\text{FLT}} = \text{OPEN}$, $C_{(\text{OUT})} = 1\ \mu\text{F}$, $C_{(\text{dVdT})} = \text{OPEN}$. (All voltages referenced to GND, (unless otherwise noted))

| PARAMETER | | TEST CONDITIONS | MIN | TYP | MAX | UNIT |
|--|--|---|-------|-------|-----------------|--------------------|
| | | $2\text{ A} \leq I_{(\text{OUT})} \leq 6\text{ A}$ | 26.22 | 27.9 | 29.58 | $\mu\text{A/A}$ |
| FAULT FLAG (FLT): ACTIVE LOW | | | | | | |
| $R_{(\text{FLT})}$ | FLT Pull-down resistance | | 36 | 70 | 130 | Ω |
| $I_{(\text{FLT})}$ | FLT Input leakage current | $0\text{ V} \leq V_{(\text{FLT})} \leq 60\text{ V}$ | - 150 | 6 | 150 | nA |
| POWER GOOD (PGOOD) | | | | | | |
| $R_{(\text{PGOOD})}$ | PGOOD Pull-down resistance | | 36 | 70 | 130 | Ω |
| $I_{(\text{PGOOD})}$ | PGOOD Input leakage current | $0\text{ V} \leq V_{(\text{PGOOD})} \leq 60\text{ V}$ | - 150 | | 150 | nA |
| POSITIVE INPUT FOR POWER GOOD COMPARATOR (PGTH) | | | | | | |
| $V_{(\text{PGTHR})}$ | PGTH threshold voltage, rising | | 1.176 | 1.2 | 1.224 | V |
| $V_{(\text{PGTHF})}$ | PGTH threshold voltage, falling | | 1.09 | 1.123 | 1.15 | V |
| $I_{(\text{PGOOD})}$ | PGTH input leakage current | $0\text{ V} \leq V_{(\text{PGTH})} \leq 60\text{ V}$ | - 150 | | 150 | nA |
| THERMAL PROTECTION | | | | | | |
| $T_{(\text{J_REG})}$ | Thermal regulation set point | | 136 | 145 | 154 | $^{\circ}\text{C}$ |
| $T_{(\text{TSD})}$ | Thermal shutdown (TSD) threshold, rising | | | 165 | | $^{\circ}\text{C}$ |
| $T_{(\text{TSDhyst})}$ | TSD hysteresis | | | 11 | | $^{\circ}\text{C}$ |
| MODE | | | | | | |
| MODE_SEL | Mode selection | MODE = Open | | | Latch | |
| | | MODE = Short to GND | | | Auto - Retry | |

(1) Parameter guaranteed by design and characterization, not tested in production

7.6 Timing Requirements

$-40^{\circ}\text{C} \leq T_A = T_J \leq +125^{\circ}\text{C}$, $4.5\text{ V} < V_{(\text{IN_SYS})} = V_{(\text{IN})} < 60\text{ V}$, $V_{(\text{SHDN})} = 2\text{ V}$, $R_{(\text{ILIM})} = 30\text{ k}\Omega$, $\text{IMON} = \text{PGOOD} = \overline{\text{FLT}} = \text{OPEN}$, $C_{(\text{OUT})} = 1\ \mu\text{F}$, $C_{(\text{dVdT})} = \text{OPEN}$. (All voltages referenced to GND, (unless otherwise noted))

| PARAMETER | | TEST CONDITIONS | MIN | NOM | MAX | UNIT |
|--|--|--|-----|--|-----|---------------|
| UVLO INPUT (UVLO) | | | | | | |
| $\text{UVLO_}t_{\text{on(dly)}}$ | UVLO switch turnon delay | UVLO \uparrow (100 mV above $V_{(\text{UVLOR})}$) to $V_{(\text{OUT})} = 100\text{ mV}$ with $V_{(\text{PGTH})} < V_{(\text{PGTHF})}$, $C_{(\text{dVdT})} \geq 10\text{ nF}$, $[C_{(\text{dVdT})}$ in nF] | | 742 + 49.5 x $C_{(\text{dVdT})}$ | | μs |
| $\text{UVLO_}t_{\text{on(fast_dly)}}$ | UVLO switch turnon delay (fast) | UVLO \uparrow (100 mV above $V_{(\text{UVLOR})}$) to FET ON with $V_{(\text{PGTH})} > V_{(\text{PGTHF})}$ | 70 | 150 | 251 | μs |
| $\text{UVLO_}t_{\text{off(dly)}}$ | UVLO switch turnoff delay | UVLO \downarrow (20 mV below $V_{(\text{UVLOF})}$) to $\overline{\text{FLT}}$ \downarrow | 9 | 11 | 16 | μs |
| $t_{\text{UVLO_FLTdly}}$ | UVLO to fault de-assertion delay | UVLO \uparrow to $\overline{\text{FLT}}$ \uparrow delay | 500 | 617 | 700 | μs |
| OVER VOLTAGE PROTECTION INPUT (OVP) | | | | | | |
| $\text{OVP_}t_{\text{OFF(dly)}}$ | OVP switch turnoff delay | OVP \uparrow (20 mV above $V_{(\text{OVPR})}$) to $\overline{\text{FLT}}$ \downarrow | 8.5 | 11 | 14 | μs |
| $\text{OVP_}t_{\text{on(fast_dly)}}$ | OVP switch turnon delay (fast) | OVP \downarrow (100 mV below $V_{(\text{OVPF})}$) to FET ON with $V_{(\text{PGTH})} > V_{(\text{PGTHF})}$ | 58 | 129 | 225 | μs |
| $\text{OVP_}t_{\text{on(dly)}}$ | OVP switch disable delay | OVP \downarrow (100 mV below $V_{(\text{OVPF})}$) to FET ON with $V_{(\text{PGTH})} < V_{(\text{PGTHF})}$, $C_{(\text{dVdT})} \geq 10\text{ nF}$, $[C_{(\text{dVdT})}$ in nF] | | 150 + 49.5 x $C_{(\text{dVdT})}$ | | μs |
| $t_{\text{OVC(dly)}}$ | Maximum duration in over voltage clamp operation | TPS26632, TPS26633, TPS26635 and TPS26636 Only | | 162 | | ms |

7.6 Timing Requirements (continued)

-40°C ≤ T_A = T_J ≤ +125°C, 4.5 V < V_(IN_SYS) = V_(IN) < 60 V, V_(SHDN) = 2 V, R_(ILIM) = 30 kΩ, IMON = PGOOD = $\overline{\text{FLT}}$ = OPEN, C_(OUT) = 1 μF, C_(dVdT) = OPEN. (All voltages referenced to GND, (unless otherwise noted))

| PARAMETER | | TEST CONDITIONS | MIN | NOM | MAX | UNIT |
|---|--|--|------|------|------|------|
| OVC_ $t_{\text{FLT(dly)}}$ | FLT assertion delay in over voltage clamp operation | TPS26632, TPS26633, TPS26635 and TPS26636 Only | | 617 | | μs |
| SHUTDOWN CONTROL INPUT ($\overline{\text{SHDN}}$) | | | | | | |
| $t_{\text{SD(dly)}}$ | SHUTDOWN entry delay | $\overline{\text{SHDN}}$ ↓ (below V _(SHUTF)) to FET OFF | 0.8 | 1 | 1.5 | μs |
| CURRENT LIMIT | | | | | | |
| $t_{\text{FASTTRIP(dly)}}$ | Hot-short response time | I _(OUT) > I _(SCP) | | 1 | | μs |
| | Soft short response | I _(FASTTRIP) < I _(OUT) < I _(SCP) | 2.2 | 3.2 | 4.5 | μs |
| $t_{\text{CL_PLIM(dly)}}$ | Maximum duration in current & (power limiting: TPS26632, TPS26633, TPS26635 and TPS26636 Only) | | 129 | 162 | 202 | ms |
| $t_{\text{CB(dly)}}$ | Maximum duration in 2x current limiting | I _(OL) < I _(OUT) ≤ I _(2xOL) | 20 | 25.5 | 31 | ms |
| $t_{\text{CBRetry(dly)}}$ | Retry delay in Pulse over current limiting | MODE = GND, TPS26631, TPS26633, TPS26635 and TPS26636 Only | 550 | 670 | 800 | ms |
| $t_{\text{CL_PLIM_FLT(dly)}}$ | FLT delay in current & (power limiting: TPS26632, TPS26633, TPS26635 and TPS26636 Only) | | 1.09 | 1.3 | 1.6 | ms |
| REVERSE CURRENT BLOCKING (RCB) COMPARATOR | | | | | | |
| $t_{\text{RCB(fast_dly)}}$ | Reverse protection comparator detection delay (reverse) | (V _(IN_SYS) - V _(OUT)) ↓ (1 V overdrive below V _(REVTH)) to V _(DRV) - V _(IN_SYS) = V _(DRV_OH) | | 0.17 | 0.37 | μs |
| $t_{\text{RCB(dly)}}$ | | (V _(IN_SYS) - V _(OUT)) ↓ (10 mV overdrive below V _(REVTH)) to V _(DRV) - V _(IN_SYS) = V _(DRV_OH) | | 0.48 | 3 | μs |
| $t_{\text{RCB(flt_dly)}}$ | Fault assertion Delay | (V _(IN_SYS) - V _(OUT)) ↓ (10 mV overdrive below V _(REVTH)) to $\overline{\text{FLT}}$ ↓ | 500 | 617 | 800 | μs |
| $t_{\text{FWD_FLT(dly)}}$ | Reverse protection comparator detection delay (forward) | (V _(IN_SYS) - V _(OUT)) ↑ (10 mV overdrive above V _(FWDTH)) to V _(BGATE) - V _(IN_SYS) = 5 V, C _(BFET-IN_SYS) = 4.7 nF | | 0.87 | | ms |
| | Fault de-assertion Delay | (V _(IN_SYS) - V _(OUT)) ↑ (10 mV overdrive above V _(FWDTH)) to FLT ↑ | 434 | 605 | 800 | μs |
| OUTPUT RAMP CONTROL (dVdT) | | | | | | |
| $t_{\text{(FASTCHARGE)}}$ | Output ramp time in fast charging | C _(dVdT) = Open, 10% to 90% V _(OUT) , C _(OUT) = 1 μF; V _(IN) = 24V | 350 | 495 | 700 | μs |
| $t_{\text{(dVdT)}}$ | Output ramp time | C _(dVdT) = 22 nF, 10% to 90% V _(OUT) , V _(IN) = 24V | | 8.35 | | ms |
| POWER GOOD (PGOOD) | | | | | | |
| t_{PGOODR} | PGOOD delay (deglitch) time | Rising edge | 1.07 | 1.3 | 1.6 | ms |
| t_{PGOODF} | PGOOD delay (deglitch) time | Falling edge, PGTH ↓ (10mV below V _(PGTHF)) | 1.3 | 2.12 | 4 | μs |
| FAULT FLAG (FLT) | | | | | | |
| $t_{\text{CB_FLT(dly)}}$ | FLT assertion delay in Pulse over current limiting | Delay from I _(OUT) > I _(OL) to $\overline{\text{FLT}}$ ↓ . TPS26631, TPS26633, TPS26635 and TPS26636 Only | 22 | 25.5 | 30 | ms |
| THERMAL PROTECTION | | | | | | |
| $t_{\text{(TSD_retry)}}$ | Retry delay in TSD | MODE = GND | 500 | 648 | 800 | ms |
| $t_{\text{(Treg_timeout)}}$ | Thermal Regulation Timeout | | 2.3 | 2.54 | 2.9 | s |

7.7 Typical Characteristics

-40°C ≤ T_A = T_J ≤ +125°C, V_(IN_SYS) = V_(IN) = 24 V, V_(SHDN) = 2 V, R_(ILIM) = 30 kΩ, IMON = PGOOD = $\overline{\text{FLT}}$ = OPEN, C_(OUT) = 1 μF, C_(dVdT) = OPEN. (Unless stated otherwise)



图 7-1. On-Resistance vs Temperature Across Load Current



图 7-2. Overvoltage Clamp Threshold vs Temperature

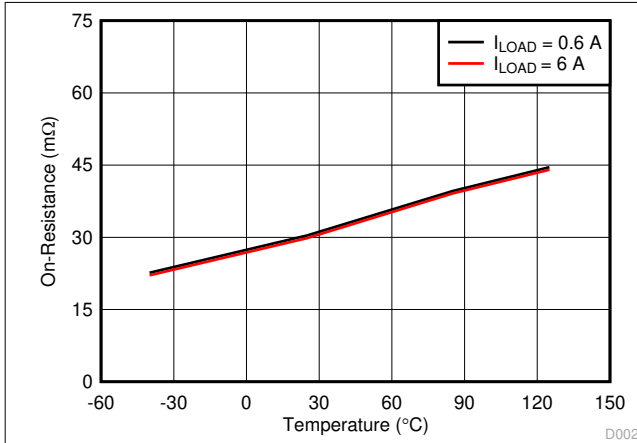

图 7-3. B_GATE Drive Voltage vs Temperature

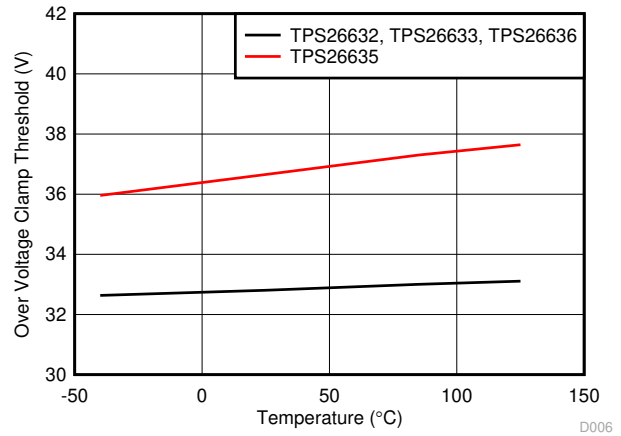

图 7-4. B_GATE Drive Current vs Temperature

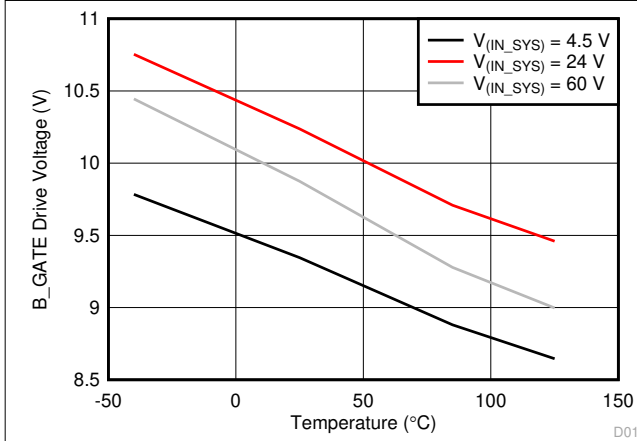

图 7-5. B_GATE Pull Down Drive Voltage vs Temperature

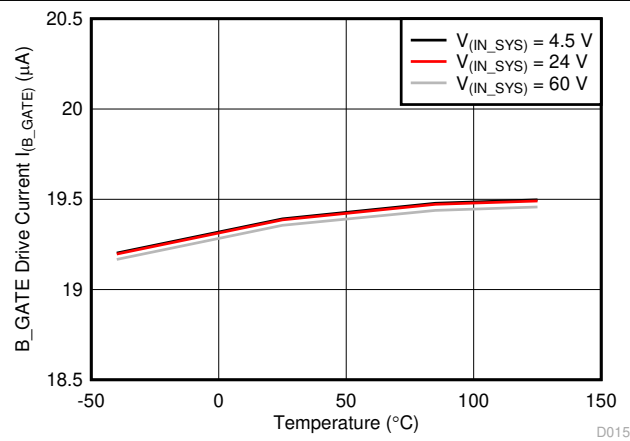

图 7-6. Input Supply Current vs Supply Voltage in Shutdown

7.7 Typical Characteristics (continued)

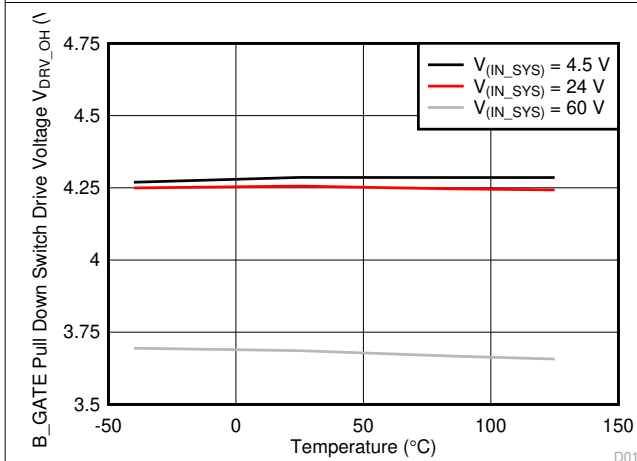
- $40^{\circ}\text{C} \leq T_A = T_J \leq +125^{\circ}\text{C}$, $V_{(\text{IN_SYS})} = V_{(\text{IN})} = 24\text{ V}$, $V_{(\text{SHDN})} = 2\text{ V}$, $R_{(\text{ILIM})} = 30\text{ k}\Omega$, $\text{IMON} = \text{PGOOD} = \overline{\text{FLT}} = \text{OPEN}$, $C_{(\text{OUT})} = 1\ \mu\text{F}$, $C_{(\text{dVdT})} = \text{OPEN}$. (Unless stated otherwise)

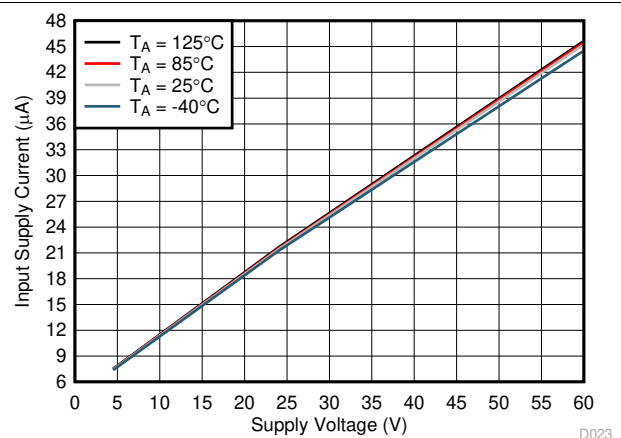

图 7-7. Input Supply Current vs Supply Voltage During Normal Operation



$V_{(\text{OUT})} = 0\text{ V}$

图 7-8. Input Supply Current vs Reverse Supply Voltage, - $V_{(\text{IN_SYS})}$

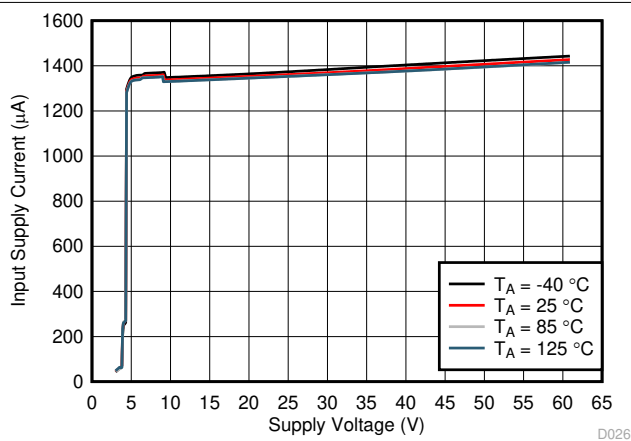
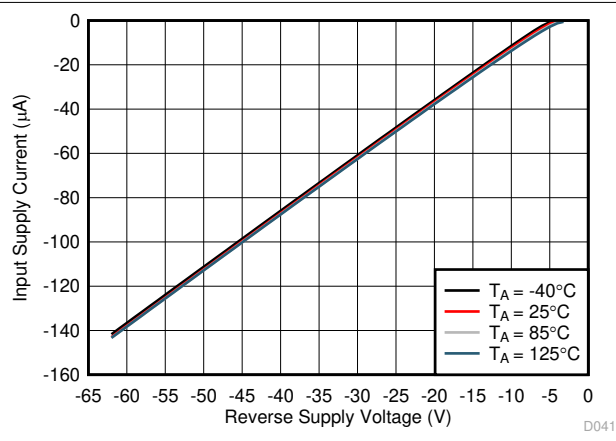

图 7-9. Overload Current Limit vs Temperature



图 7-10. Overload Current Limit vs Temperature

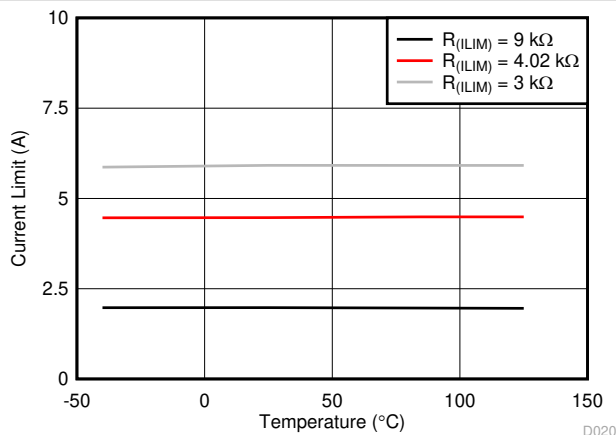

图 7-11. Output Power Limiting Accuracy vs PLIM

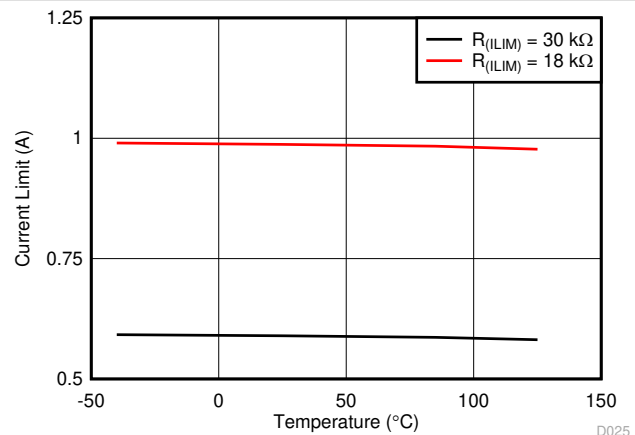

TPS26632 $R_{(\text{PLIM})} = 100\text{ k}\Omega$ $R_{(\text{ILIM})} = 3\text{ k}\Omega$
图 7-12. Power Limit, Current limit vs Supply Voltage

7.7 Typical Characteristics (continued)

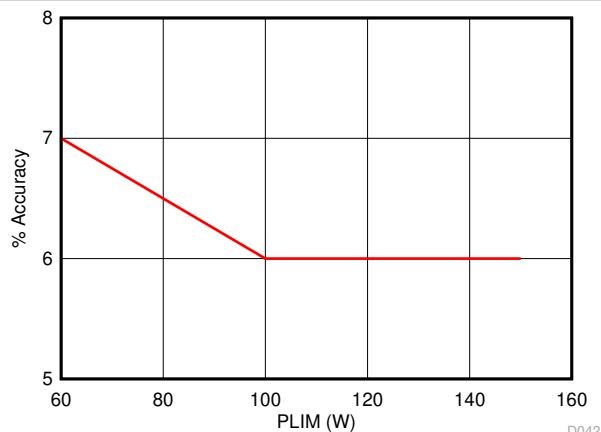
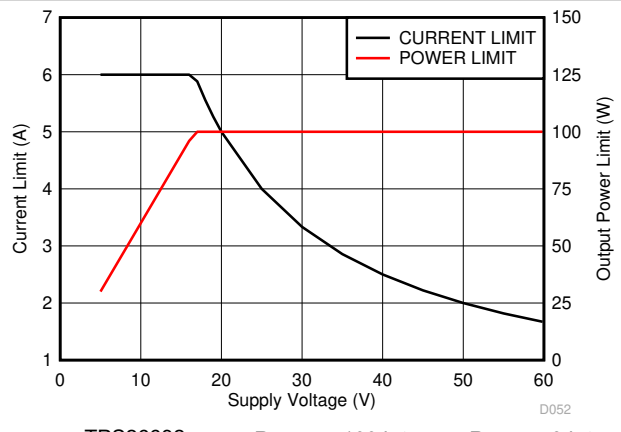
$-40^{\circ}\text{C} \leq T_A = T_J \leq +125^{\circ}\text{C}$, $V_{(IN_SYS)} = V_{(IN)} = 24\text{ V}$, $V_{(SHDN)} = 2\text{ V}$, $R_{(ILIM)} = 30\text{ k}\Omega$, $IMON = PGOOD = \overline{FLT} = \text{OPEN}$, $C_{(OUT)} = 1\ \mu\text{F}$, $C_{(dVdT)} = \text{OPEN}$. (Unless stated otherwise)



图 7-13. Current Monitor Output vs Output Current



图 7-14. IMON Gain Accuracy at < 0.6-A Output Current

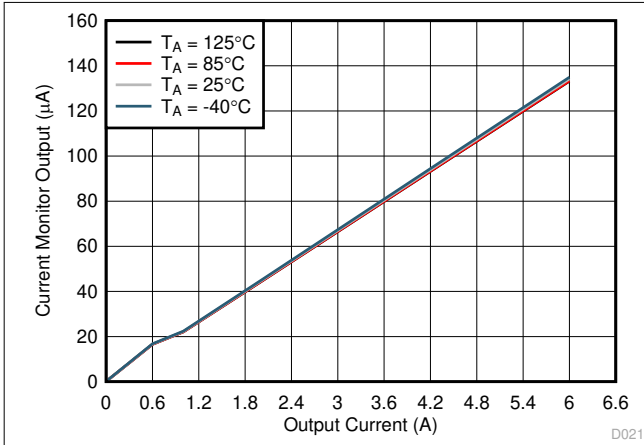

图 7-15. UVLO, OVP Fast Turn ON Delay vs Temperature

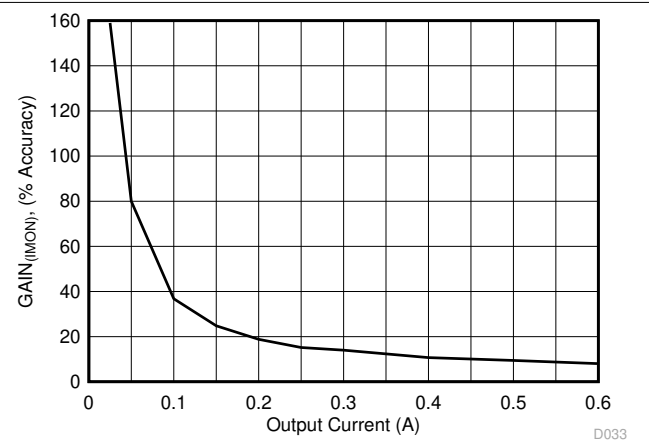

图 7-16. Maximum Duration in Current and Power Limiting vs Temperature

A. $V_{(PGTH)} > V_{(PGTHF)}$

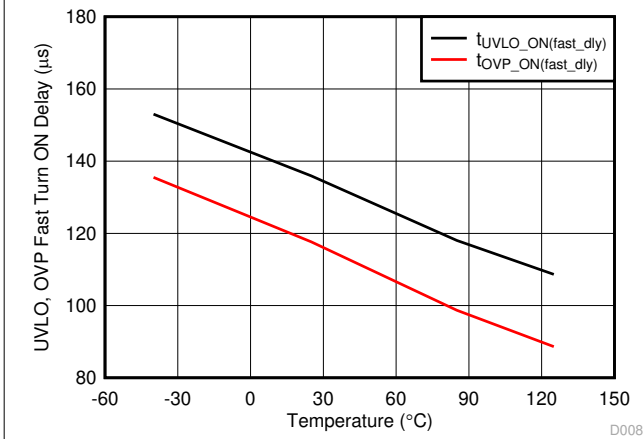

图 7-17. Reverse Current Blocking Response vs Temperature

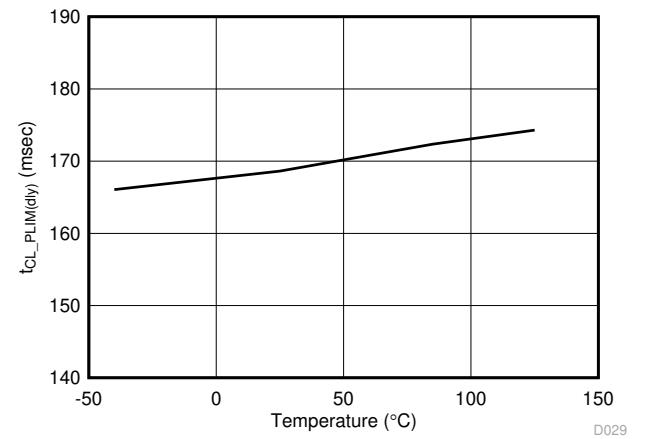

图 7-18. Thermal Shutdown Time vs Power Dissipation
Taken on VQFN device on EVM Board

8 Parameter Measurement Information

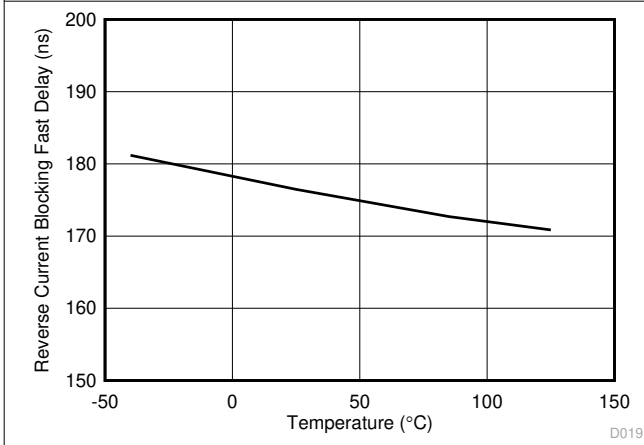

图 8-1. Timing Waveforms

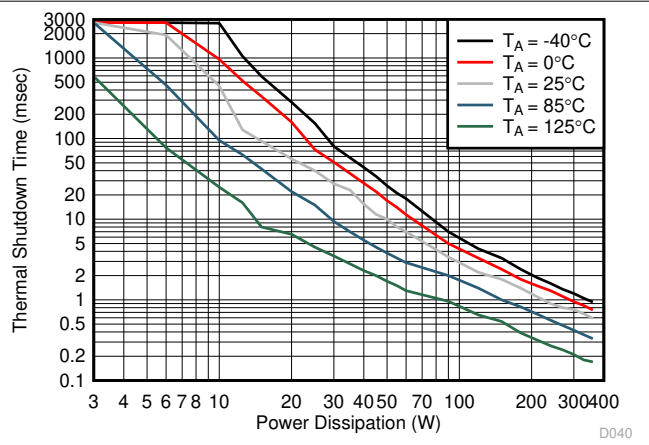

图 8-2. Timing Waveforms

9 Detailed Description

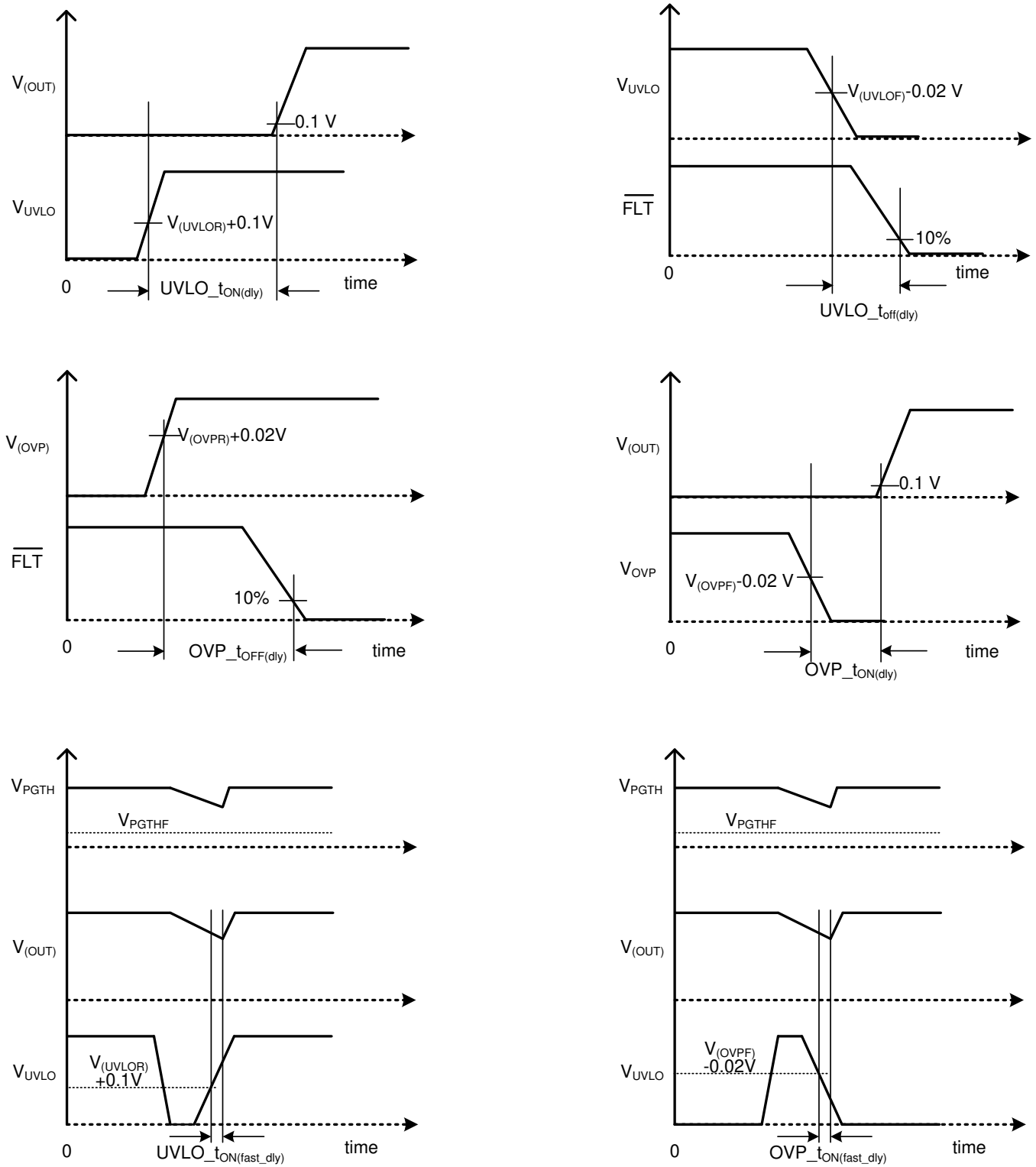
9.1 Overview

The TPS2663x devices are a family of 60-V industrial eFuses. The devices provides robust protection for all systems and applications powered from 4.5 V to 60 V. With an external N-channel FET the devices can be used to protect the loads from negative supply voltages down to - 60 V. For hot-pluggable boards, the devices provides hot-swap power management with in-rush current control and programmable output voltage slew rate features using the dVdT pin. Load, source and device protections are provided with many programmable features including overcurrent, overvoltage and undervoltage. The precision overcurrent limit ($\pm 7\%$ at 6 A) helps to minimize over design of the input power supply, while the fast response short circuit protection 1- μs (typical) immediately isolates the faulty load from the input supply when a short circuit is detected. The device features fast reverse current blocking response (0.17 μs). The internal robust protection control blocks of the TPS2663x along with its $\pm 60\text{-V}$ rating, helps to simplify the system designs for the industrial surge compliance ensuring complete protection of the load and the device. The 60-V maximum DC operating and 70-V absolute maximum voltage rating enables system protection from 60-V DC input supply faults and from industrial SELV power supplies.

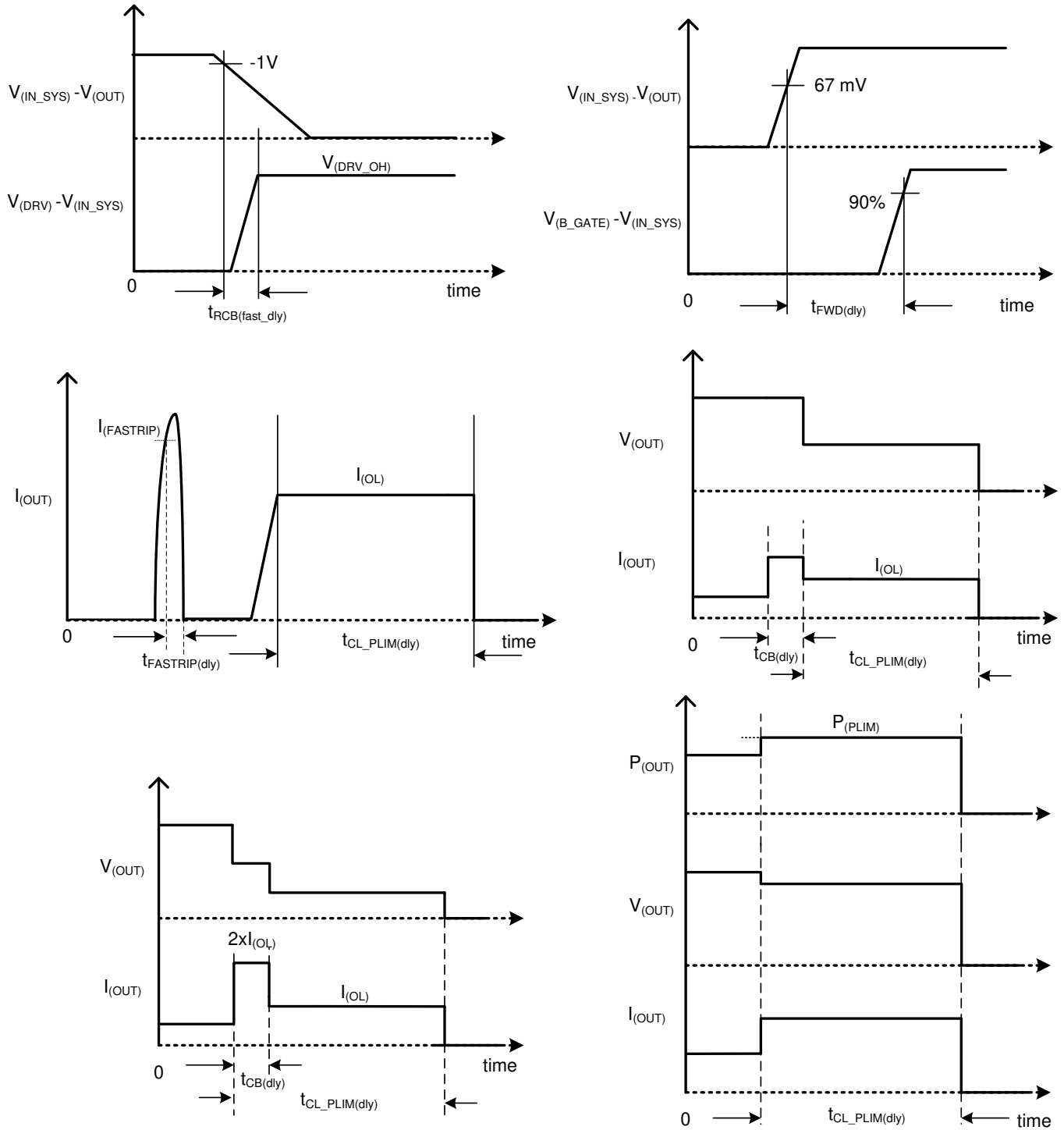
By monitoring the output (Load) voltage through the PGTH pin, the device distinguishes between real system faults and system transients and the turn ON delay during a fault recovery is controlled accordingly. The valid load voltage detection threshold can be adjusted using a resistor ladder network from OUT, PGTH and GND. This scheme ensures fast recovery during system tests like voltage interruption and brown-out tests, EMC testing like Electrical Fast Transients (IEC61000-4-4) and Surge (IEC61000-4-5).

The TPS26632, TPS26633, TPS26635 and TPS26636 devices integrate adjustable output power limiting (PLIM) functionality that simplifies the system design requiring compliance in accordance to standards like IEC61010-1 and UL1310.

The devices provides precise monitoring of voltage bus for brown-out, overvoltage conditions and asserts fault signal for the downstream system. Its overall threshold accuracy of 2% ensures tight supervision of bus, eliminating the need for a separate supply voltage supervisor chip. The devices monitors $V_{(IN_SYS)}$ and $V_{(OUT)}$ to provide true reverse current blocking when a reverse condition or input power failure condition is detected.

Additional features of the TPS2663x devices include:

- $\pm 6\%$ Current monitor output (IMON) for health monitoring of the system
- A choice of latch off or automatic restart mode response during current limit, power Limit and thermal fault using MODE pin
- PGOOD indicator output with $\pm 2\%$ accurate adjustable valid load voltage detection threshold (PGTH)
- Over temperature protection to safely shutdown in the event of an overcurrent event
- De-glitched fault reporting for supply brown-out and overvoltage faults
- Enable and disable control from an MCU using $\overline{\text{SHDN}}$ pin

9.2 Functional Block Diagram

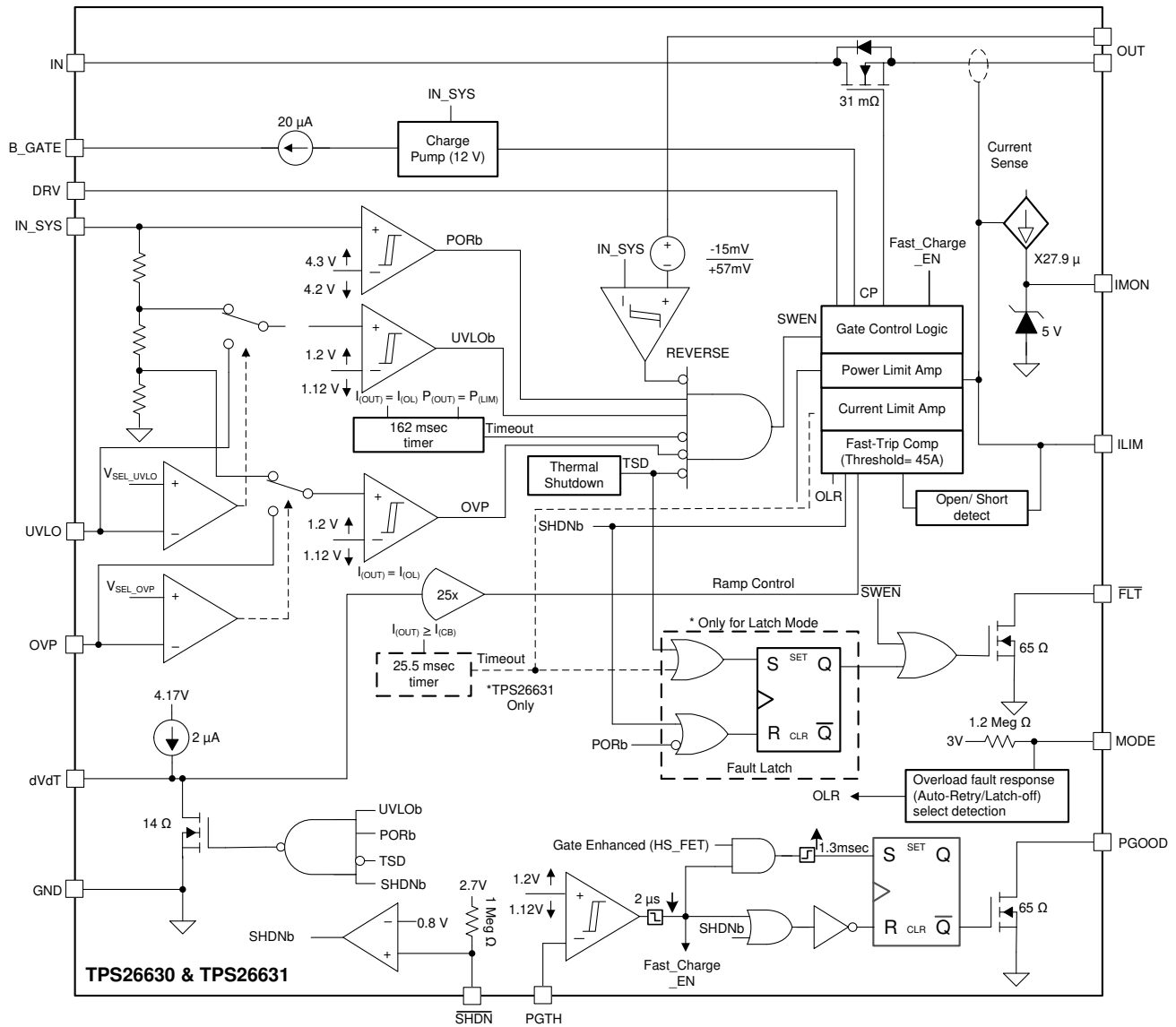

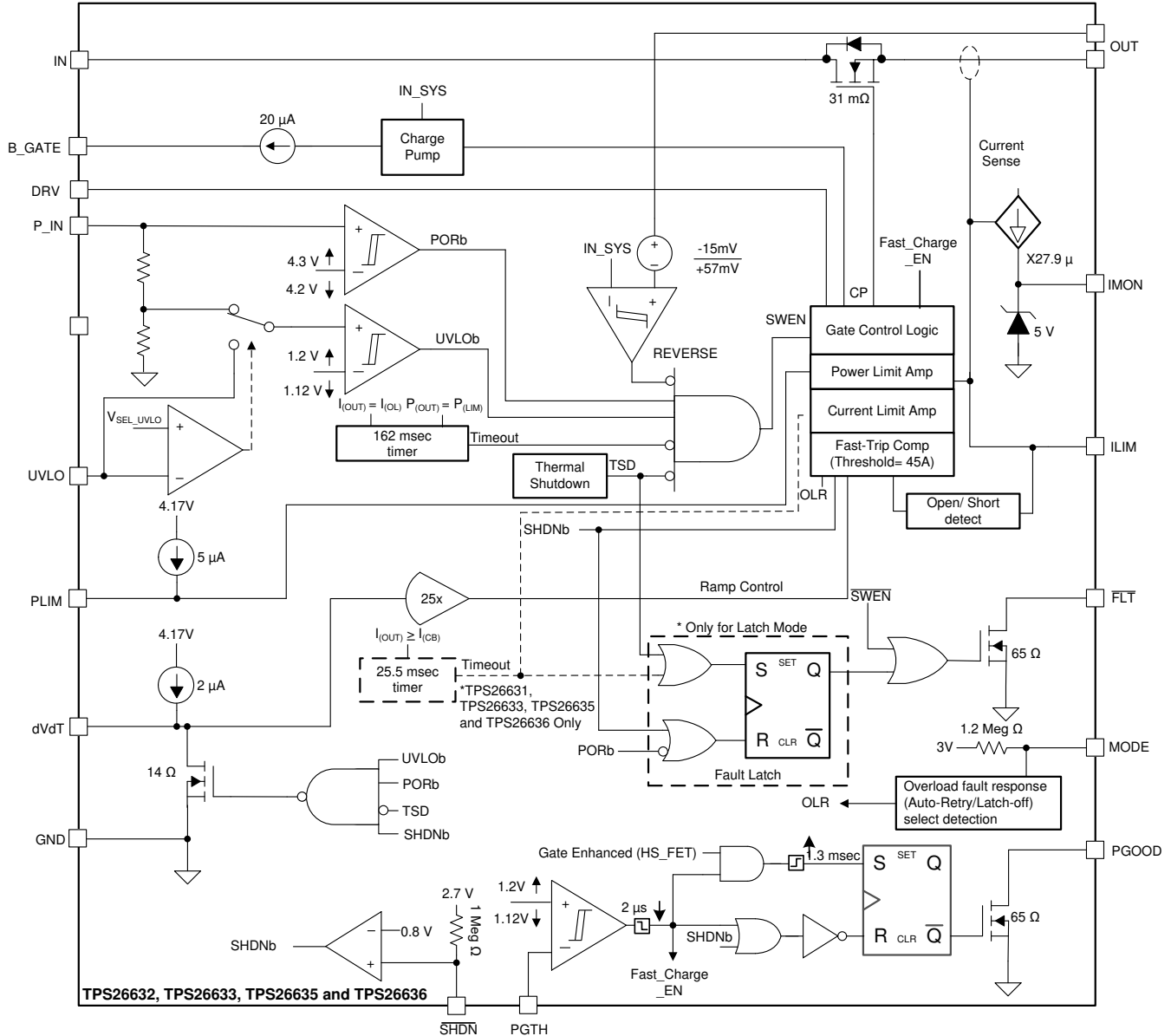

9.3 Feature Description

9.3.1 Hot Plug-In and In-Rush Current Control

The devices are designed to control the inrush current upon insertion of a card into a live backplane or other "hot" power source. This limits the voltage sag on the backplane's supply voltage and prevents unintended resets of the system power. The controlled start-up also helps to eliminate conductive and radiative interferences. An external capacitor connected from the dVdT pin to GND defines the slew rate of the output voltage at power-on. The fastest output slew rate of 24 V/500 μs can be achieved by leaving dVdT pin floating. The inrush current can be calculated using [方程式 1](#).

$$I = C \times \frac{dV}{dT} \geq I_{(INRUSH)} = C_{(OUT)} \times \frac{V_{(IN)}}{t_{dVdT}} \tag{1}$$

where

$$t_{dVdT} = 20.8 \times 10^3 \times V_{(IN)} \times C_{(dVdT)} \tag{2}$$

Figure 8-1 illustrates in-rush current control performance of the device during Hot Plug-In.



图 9-1. Hot Plug In and Inrush Current Control at 24-V Input

9.3.1.1 Thermal Regulation Loop

The average power dissipation within the eFuse during power up with a capacitive load can be calculated using 方程式 3.

$$P_{D(INRUSH)} = 0.5 \times V_{(IN)} \times I_{(INRUSH)} \quad (3)$$

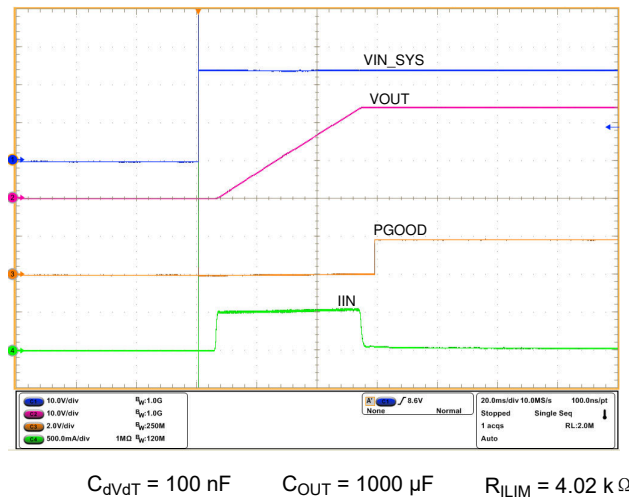
System designs requiring to charge large output capacitors rapidly may result in an operating point that exceeds the power dissipation versus time boundary limits of the device defined by 图 7-18 characteristic curve. This may result in increase in junction temperature beyond the device's maximum allowed junction temperature. To keep the junction temperature within the operating range, the thermal regulation control loop regulates the junction temperature at $T_{(J_REG)}$, 145°C (typical) by controlling the inrush current profile and thereby limiting the power dissipation within the device automatically. An internal 2.5 seconds (typical) timer starts from the instance the thermal regulation operation kicks in. If the output does not power up within this time then the internal FET is turned OFF. Subsequent operation of the device depends on the MODE configuration (Auto-Retry or latch OFF) setting as shown in 表 9-1. The maximum time-out of 1.25 seconds (typical) in thermal regulation loop operation ensures that the device and the system board does not heat up during steady fault conditions such as wake up with output short-circuit. This scheme ensures reliable power up operation.

Thermal regulation control loop is internally enabled during power up by $V_{(IN)}$, UVLO cycling and turn ON using SHDN control. Figure 8-2 illustrates performance of the device operating in thermal regulation loop during power up by $V_{(IN)}$ with a large output capacitor. The Thermal regulation loop gets disabled internally after the power up sequence when the internal FET's gate gets fully enhanced or when the $t_{(Treg_timeout)}$ of 2.5 seconds (typical) time is elapsed.

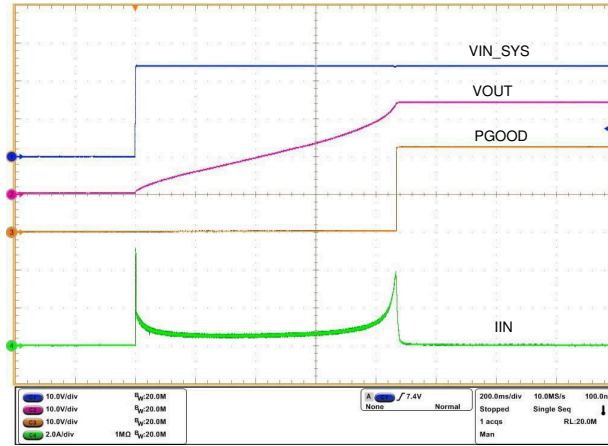

$C_{dVdT} = \text{Open}$ $C_{OUT} = 30 \text{ mF}$ $R_{ILIM} = 4.02 \text{ k}\Omega$

图 9-2. Thermal Regulation Loop Response During Power Up with Large Capacitive Load

9.3.2 PGOOD and PGTH

The devices feature an open drain Power good (PGOOD) indicator output. PGOOD can be used for enable and disable of the downstream loads like DC-DC converters. Connect a resistor ladder network from VOUT, PGTH and GND to set the PGOOD threshold level. PGOOD goes high when the internal FET's gate is enhanced and $V_{(PGTH)}$ is above $V_{(PGTHR)}$. PGOOD goes low when $V_{(PGTH)}$ goes below $V_{(PGTHF)}$. There is a deglitch of t_{PGOODR} , 1.2 msec (typical) at the rising edge and t_{PGOODR} , 2.1 μs (typical) deglitch on the falling edge of PGOOD indication. PGOOD is a rated for 60 V and can be pulled to IN_SYS or OUT through a resistor. PGTH can be used for setting downstream's supply UVLO levels and PGOOD as enable and disable control.

9.3.2.1 PGTH as VOUT Sensing Input

The devices use PGTH as the output (Load) voltage monitor input and to set the down stream loads UVLO threshold. To set the input PGTH threshold, connect a resistor divider network from VOUT to PGTH terminal to GND as shown in the [Simplified Schematic](#). During a system fault recovery (example: OVP high to low or UVLO low to high) when the internal FET gate control is enabled, the device samples the PGTH information and decides whether to turn ON the FET with fast slew rate or dVdT mode based on the sampled $V_{(PGTH)}$ information.

图 8-1 shows the turn ON behavior based on $V_{(PGTH)}$ information. During the fault recovery instance if the $V_{(PGTH)}$ level is above $V_{(PGTHF)}$ then the internal FET turns ON within a delay of $t_{OVP(dly_fast)}$ with fast slew rate (ignores the capacitance connected at dVdT pin) with thermal regulation loop enabled for a duration of $t_{CL_PLIM(dly)}$. Maximum current through the device during this operation is limited at $I_{(OL)}$ in TPS26630 and TPS26632 devices and at $2 \times I_{(OL)}$ in TPS26631, TPS26633, TPS26635 and TPS26636 devices for a maximum duration of $t_{CB(dly)}$. During the fault recovery instance if the $V_{(PGTH)}$ level is below $V_{(PGTHF)}$ then the device turns ON the internal FET in dVdT mode and the slew rate will depend on the dVdT capacitor value and maximum current through the devices is limited at $I_{(OL)}$. This way the device distinguishes between real system faults and system transients and the turn ON delay is controlled accordingly. This scheme ensures fast recovery during system tests like voltage interruption and brown-out tests, EMC testing like Electrical Fast Transients (IEC61000-4-4) and Surge (IEC61000-4-5). The fast turn ON during transient recovery feature can be disabled by connecting PGTH to GND. In this case, PGOOD will be pulled low.

9.3.3 Undervoltage Lockout (UVLO)

The TPS2663x devices feature an accurate $\pm 2\%$ adjustable undervoltage lockout functionality. When the voltage at UVLO pin falls below $V_{(UVLOF)}$ during input undervoltage fault, the internal FET quickly turns off and $\overline{\text{FLT}}$ is asserted. The UVLO comparator has a hysteresis of 78 mV (typical). To set the input UVLO threshold, connect a resistor divider network from IN supply to UVLO terminal to GND as shown in the [Simplified Schematic](#). The TPS2663x devices also features a factory set 15-V input supply undervoltage lockout

$V_{(IN_SYS_UVLO)}$ threshold with 1-V hysteresis. This feature can be enabled by connecting the UVLO terminal directly to the GND terminal. If the Undervoltage Lock-Out function is not needed, the UVLO terminal must be connected to the IN_SYS terminal. UVLO terminal must not be left floating. In the applications where reverse polarity protection is required connect a minimum of 300-k Ω resistor between UVLO and IN_SYS.

图 8-1 shows the turn ON behavior when UVLO pin voltage exceeds $V_{(UVLOR)}$ threshold.

9.3.4 Overvoltage Protection (OVP)

The TPS2663x devices incorporate circuitry to protect the system during overvoltage conditions. The TPS26630 and TPS26631 feature an accurate $\pm 2\%$ adjustable overvoltage cut off functionality. A voltage more than $V_{(OVPR)}$ on OVP pin turns off the internal FET and protects the downstream load. To program the OVP threshold externally, connect a resistor divider from IN_SYS supply to OVP terminal to GND as shown in the [Simplified Schematic](#).

The TPS26630 and TPS26631 also feature a factory set 34.3-V input overvoltage cut off $V_{(IN_SYS_OVP)}$ threshold with a 440 mV hysteresis. This feature can be enabled by connecting the OVP terminal directly to the GND terminal. The TPS26632, TPS26633 and TPS26636 feature an internally fixed 35-V maximum overvoltage clamp $V_{(OVC)}$ functionality. The TPS26632 and TPS26633 clamps the output voltage to $V_{(OVC)}$, when the input voltage exceeds 35 V. TPS26635 features a fixed 39-V maximum overvoltage clamp level. During the output voltage clamp operation, the power dissipation in the internal MOSFET is $PD = (V_{(IN_SYS)} - V_{(OVC)}) \times I_{(OUT)}$. Excess power dissipation for a prolonged period can increase the device temperature. To avoid this, the internal FET is operated in overvoltage clamp for a maximum duration of $t_{(OVC(dly))}$, 162 msec (typical). After this duration, the internal FET is turned OFF and the subsequent operation of the device depends on the MODE configuration (Auto-Retry or latch OFF) setting as shown in 表 9-1.

图 8-1 shows the turn ON behavior when OVP pin voltage falls below $V_{(OVPF)}$ threshold.

图 9-3 illustrates the overvoltage cut-off functionality and 图 9-4 illustrates the overvoltage clamp functionality. FLT is asserted after a delay of 617 μ s (typical) after entering in overvoltage clamp mode and remains asserted until the overvoltage fault is removed.

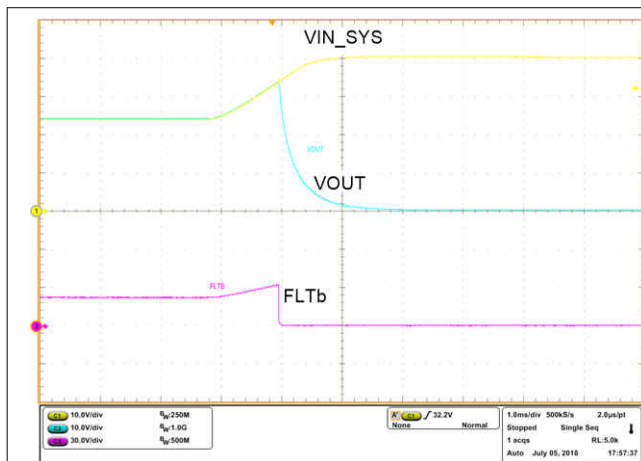

TPS26630 and TPS26631

图 9-3. Overvoltage Cut-off Response at 33-V Level

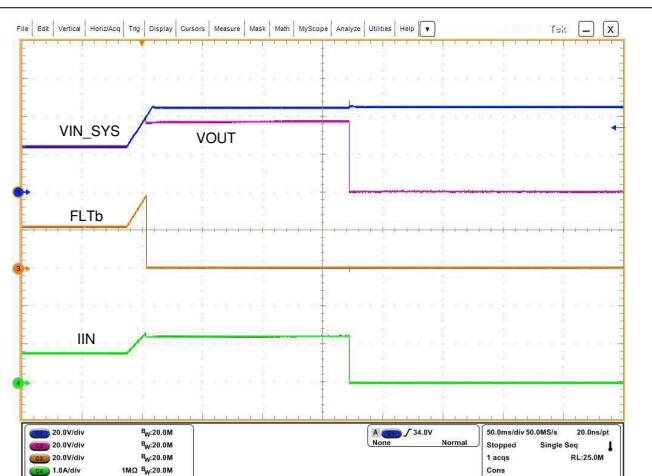

TPS26635

$R_{LOAD} = 30 \Omega$, FLT
connected to VOUT

图 9-4. Overvoltage Clamp Response with
TPS26635

9.3.5 Input Reverse Polarity Protection (B_GATE, DRV)

The TPS2663x devices support the reverse input polarity protection feature. Connect an N-channel power FET (Q1) with the source to IN_SYS, drain to IN and GATE to B-GATE as shown in 图 9-5. This forms a back to back FET topology in power path that is required to protect the load from input reverse polarity faults. Connect an

external signal FET (Q2) across BGATE, DRV and IN_SYS. Q2 acts as a pull down gate switch for Q1. In the applications where reverse polarity protection and reverse current blocking is not required then connect IN_SYS and IN together. Leave BGATE and DRV open as shown in 图 9-6.

Figure 8-7 illustrates the reverse input polarity protection functionality.

The TPS2663x devices support a maximum differential voltage across $V_{(IN_SYS)} - V_{(OUT)}$ upto -85 V . This high voltage transients generally appear during the IEC61000-4-5 surge testing at the $V_{(IN_SYS)}$. This voltage stress appears across the external N-channel FET. The TPS2663x provides a gate drive (B_GATE) of 10.2 V (typical). The fast pull down gate switch Q2 pulls down the GATE of the Q1 during reverse current and reverse polarity fault events. Q2 should be at least 15-V, VDS rated FET with a maximum VGS rating of 20-V, Ciss $\leq 50\text{ pF}$ and VGTH(min) $\leq 3\text{ V}$.



图 9-7. Input Reverse Polarity Response at -60-V Input

9.3.6 Reverse Current Protection

The device monitors $V_{(IN_SYS)}$ and $V_{(OUT)}$ to provide true reverse current blocking when a reverse condition or input power failure condition is detected. The reverse comparator turns OFF the external blocking FET Q1 quickly as soon as $V_{(IN_SYS)} - V_{(OUT)}$ falls below -1 V . The total time taken to turn OFF the FET Q1 in this condition is $t_{RCB(\text{fast_dly})} + t_{(\text{Driver})}$. The delay due to the driver stage $t_{(\text{Driver})}$ can be calculated using 方程式 4.

$$t_{(\text{Driver})} = -RDSON_{(Q2)} \times Ciss_{(Q1)} \times \ln\left(\frac{VGTH_{(Q1)}}{V_{BGATE}}\right) \quad (4)$$

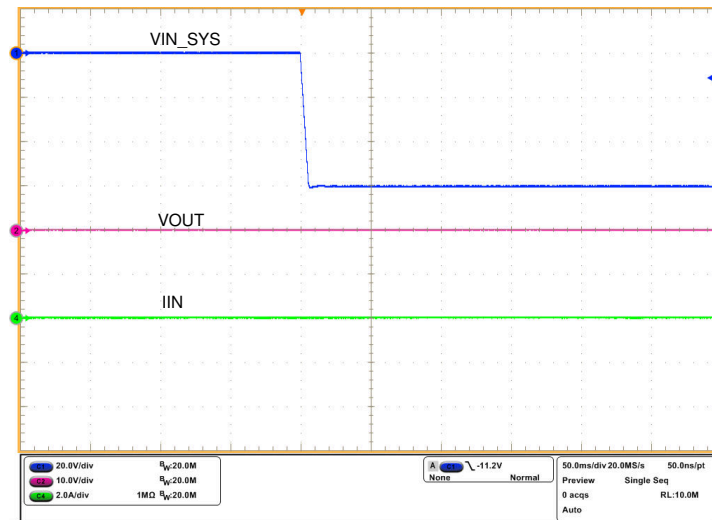
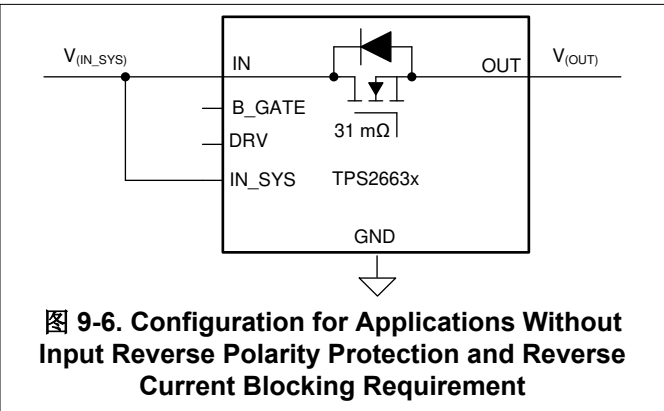
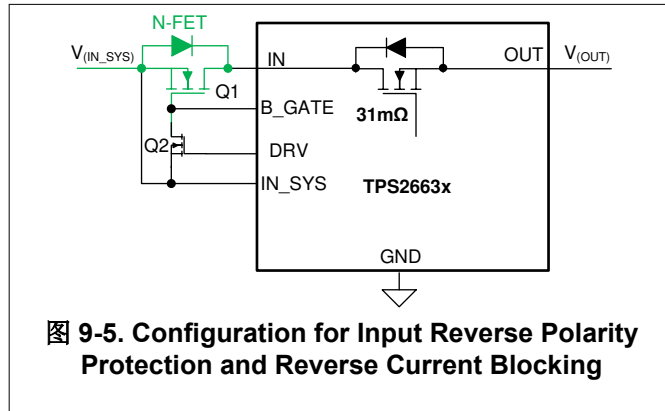
where

- $R_{DS(on)Q2}$ is the on resistance of the fast pull down switch Q2
- $C_{iss(Q1)}$ is the input capacitance of the blocking FET Q1
- $V_{GTH(Q1)}$ is the GATE threshold voltage of the blocking FET Q1
- $V_{BGATE} = 10.2\text{ V}$ (typical)

In a typical system design, $t_{(Driver)}$ is generally 10% to 20% of $t_{RCB(fast_dly)}$ of 120 nsec (typical).

图 9-8 and 图 9-9 illustrates the behavior of the system during input hot short circuit condition. The blocking FET Q1 is turned ON within 1.6 ms (typical) once the differential forward voltage $V_{(IN_SYS)} - V_{(OUT)}$ exceeds 67 mV (typical).



图 9-8. Input Hot Short Functionality at 24-V Supply



图 9-9. Input Hot-Short: Fast Trip Response (Zoomed)

The reverse comparator architecture has a supply line noise immunity resulting in a robust performance in noisy environments. This is achieved by controlling the turn OFF time of the internal FET based on the over-drive differential voltage $V_{(IN_SYS)} - V_{(OUT)}$ over $V_{(REVTH)}$. Higher the over-drive, faster the turn OFF time, $t_{RCB(dly)}$.

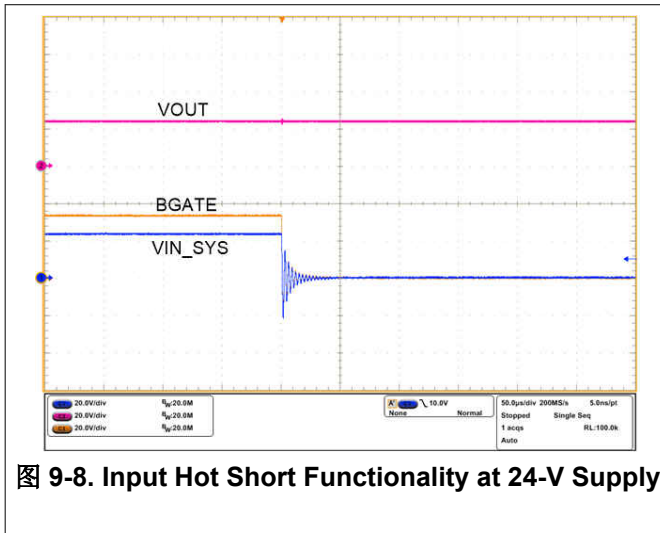
9.3.7 Overload and Short Circuit Protection

The device monitors the load current by sensing the voltage across the internal sense resistor. The FET current is monitored during start-up and normal operation.

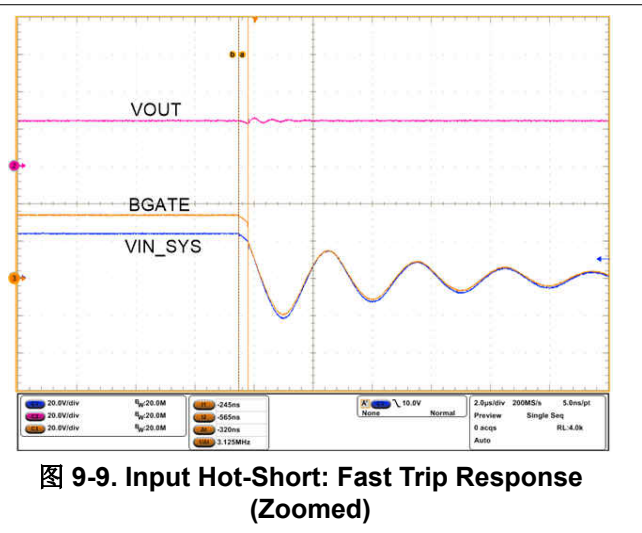
9.3.7.1 Overload Protection

Set the current limit using 方程式 5

$$I_{OL} = \frac{18}{R_{(ILIM)}} \quad (5)$$

where

- $I_{(OL)}$ is the overload current limit in Ampere
- $R_{(ILIM)}$ is the current limit resistor in $k\Omega$

9.3.7.1.1 Active Current Limiting at $1x I_{OL}$, (TPS26630 and TPS26632 Only)

The TPS2663x devices feature accurate overload current limiting and fast short circuit protection feature. With TPS26630 and TPS26632 if the load current exceeds the programmed current limit I_{OL} , the device regulates the current through it at I_{OL} eventually reducing the output voltage. The power dissipation across the device during this operation will be $(V_{IN} - V_{OUT}) \times I_{OL}$ and this could heat up the device and eventually enter into thermal shutdown. The maximum duration for the overcurrent through the FET $t_{CL_PLIM(dly)}$, 162 msec (typical). If the thermal shutdown occurs before this time the internal FET turns OFF and the subsequent operation (auto-retry

or latch OFF) will depend on the MODE pin configuration in 表 9-1. Figure 9-10 and Figure 9-11 illustrate overload current limiting performance.

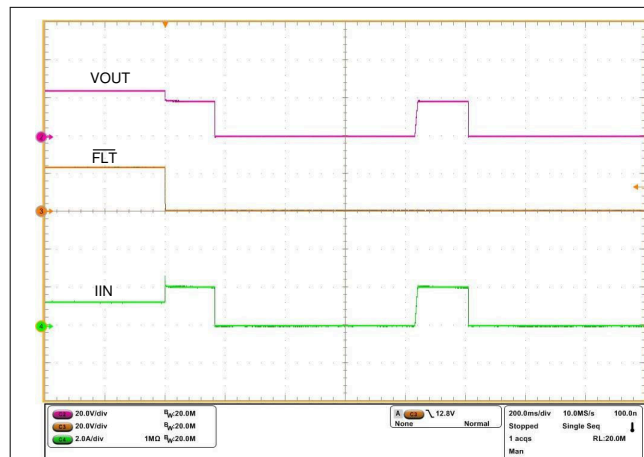

$V_{IN_SYS} = 24\text{ V}$ MODE connected
to GND (Auto-
Retry) $R_{ILIM} = 9\text{ k}\Omega$

图 9-10. Overload Performance with TPS26630, TPS26632 during Load Step from 19 Ω to 9 Ω

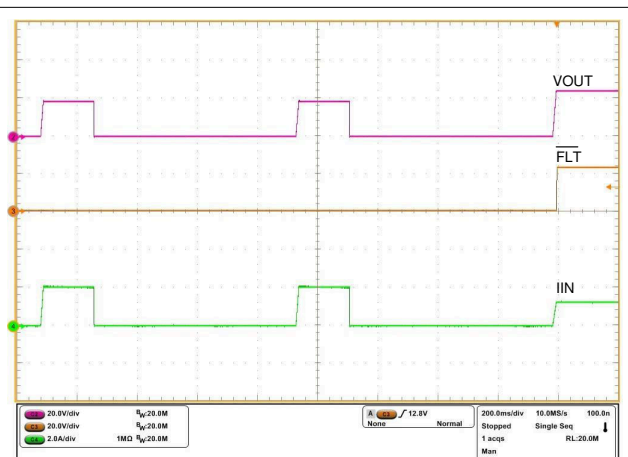

$V_{IN_SYS} = 24\text{ V}$ MODE connected
to GND (Auto-
Retry) $R_{ILIM} = 9\text{ k}\Omega$

图 9-11. Response During Coming Out of Overload Fault

9.3.7.1.2 Active Current Limiting with 2x I_{OL} Pulse Current Support, (TPS26631, TPS26633, TPS26635 and TPS26636 Only)

TPS26631, TPS26633, TPS26635 and TPS26636 after the start-up and with PGOOD high, if the load current exceeds I_{OL} , then an internal fixed $t_{CB(dly)}$, 25.5 msec (typical) timer starts. During this time the device will pass through the over current demanded by the load not more than 2 x I_{OL} above which the device will regulate at 2 x I_{OL} . After $t_{CB(dly)}$ time, the device regulates the current at I_{OL} . The power dissipation across the device during this operation will be $(V_{IN} - V_{OUT}) \times I_{OL}$ and this could heat up the device and eventually enter into thermal shutdown. The maximum duration for the internal FET in current regulation is $t_{CL_PLIM(dly)}$. The subsequent operation will be based on the MODE setting (either auto-retry or latch OFF) in 表 9-1.

The 2 x $I_{(OL)}$ pulse current support is activated only after PGOOD goes high. If PGOOD is in low state such as during start-up operation or during auto-retry cycles, the 2 x $I_{(OL)}$ pulse current support is not activated and the device limits the current at $I_{(OL)}$ level.

图 9-12 and 图 9-13 illustrate overload current limiting performance.

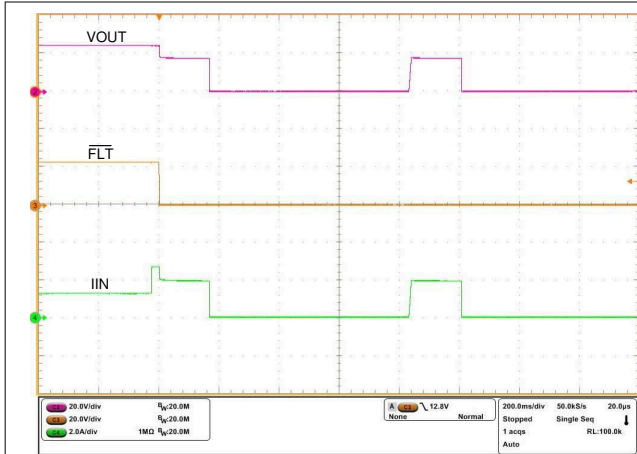

$V_{IN_SYS} = 24\text{ V}$ MODE connected to GND (Auto-Retry) $R_{ILIM} = 9\text{ k}\Omega$

图 9-12. Overload Performance with TPS26631, TPS26633, TPS26635 and TPS26636 during Load Step from 19 Ω to 9 Ω

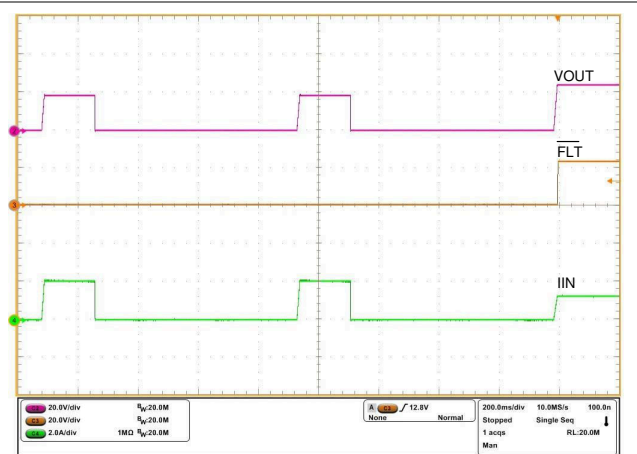

$V_{IN_SYS} = 24\text{ V}$ MODE connected to GND (Auto-Retry) $R_{ILIM} = 9\text{ k}\Omega$

图 9-13. Response during Coming Out of Overload Fault

The TPS2663x devices feature ILIM pin short and open fault detection and protection. The internal FET is turned OFF when ILIM pin is detected short or open to GND and it remains OFF till the ILIM pin fault is removed.

Refer to 图 8-2 for more information on $t_{CB(dly)}$ and $t_{CL_PLIM(dly)}$ parameter measurement information.

9.3.7.2 Short Circuit Protection

During a transient output short circuit event, the current through the device increases rapidly. As the current-limit amplifier cannot respond quickly to this event due to its limited bandwidth, the device incorporates a fast-trip comparator. The fast-trip comparator architecture is designed for fast turn OFF $t_{FASTTRIP(dly)} = 1\ \mu\text{s}$ (typical) with $I_{(SCP)} = 45\text{ A}$ of the internal FET during an output short circuit event. The fast-trip threshold is internally set to $I_{(FASTTRIP)}$. The fasttrip circuit holds the internal FET off for only a few microseconds, after which the device turns back on slowly, allowing the current-limit loop to regulate the output current to $I_{(OL)}$. Then the device functions similar to the overload condition. Figure 8-14 illustrates output hot-short performance of the device.

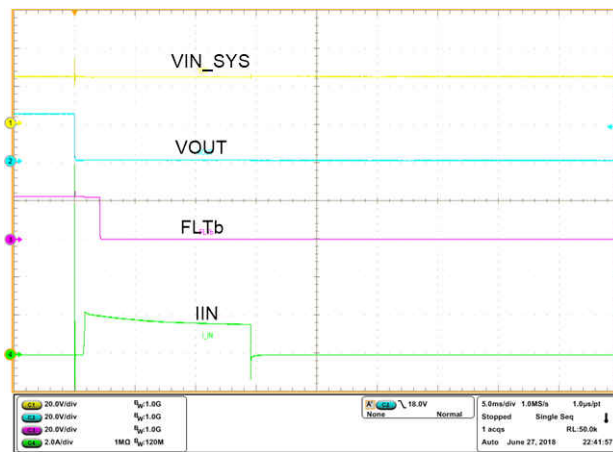

$V_{IN_SYS} = 24\text{ V}$ $R_{ILIM} = 9.09\text{ k}\Omega$

图 9-14. Output Hot-Short Response

The fast-trip comparator architecture has a supply line noise immunity resulting in a robust performance in noisy environments. This is achieved by controlling the turn OFF time of the internal FET based on the overcurrent level, $I_{FASTTRIP}$ through the device. Higher the overcurrent, faster the turn OFF time, $t_{FASTTRIP(dly)}$. At overload current level in the range of $I_{FASTTRIP} < I_{OUT} < I_{SCP}$ the fast-trip comparator response is 3.2 μ s (typical).

9.3.7.2.1 Start-Up With Short-Circuit On Output

When the device is started with short-circuit on the output, the current begins to limit at I_{OL} . Due to high power dissipation of $V_{IN} \times I_{OL}$ within the device the junction temperature increases. Subsequently, the thermal regulation control loop limits the load current to regulate the junction temperature at $T_{(J_REG)}$, 145°C (typical) for a duration of $t_{(Treg_timeout)}$, 2.5 sec (typical). Subsequent operation of the device depends on the MODE configuration (Auto-Retry or latch OFF) setting as per the 表 9-1. \overline{FLT} gets asserted after $t_{(Treg_timeout)}$ and remains asserted till the output short-circuit is removed. 图 9-15 illustrates the behavior of the device in this condition.

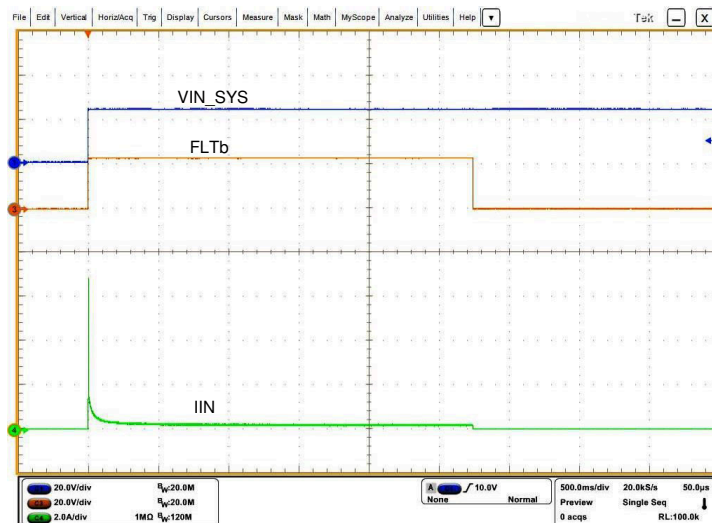

A.

$$V_{IN} = 24V$$

$$R_{LIM} = 3\text{ k}\Omega$$

图 9-15. Start-Up With Short on Output

9.3.8 Output Power Limiting, PLIM (TPS26632, TPS26633, TPS26635 and TPS26636 Only)

The TPS26630 and TPS26631 devices with a fixed overcurrent limit threshold the maximum output power limit increases linearly with supply input. Electrical industrial process control equipment such as PLC CPU needs to comply with standards like IEC61010-1 and UL1310 for fire safety, which require limited energy and power circuits. Limiting the output power becomes a challenge in such high power applications where the operating supply voltage range is wide. The TPS26632, TPS26633, TPS26635 and TPS26636 devices integrate adjustable output power limiting functionality that simplifies the system design requiring compliance in accordance to this standard.

Connect a resistor from PLIM to GND as shown in 图 9-16 to set the output power limiting value. If output power limiting is not required then connect PLIM to GND directly. This disables the PLIM functionality.

During an over power load event the TPS26632 limits the output power at the programmed value set by PLIM resistor. This indirectly results in the device operation in current limiting mode with steady state output voltage and current set by the load characteristics and $P_{LIM} = V_{OUT} \times I_{OUT}$. 图 7-12 shows the output power limit and current limit characteristics of TPS26632 with 100 W power limit setting. The maximum duration for the device in power limiting mode is 162 msec (typical), $t_{CL_PLIM(dly)}$. After this time, the device operates either in auto-retry or latch off mode based on MODE pin configuration in 表 9-1.

During an over power load event the TPS26633, TPS26635 and TPS26636 allows the extra power for a maximum duration of $t_{CB(dly)}$, 25.5 msec (typical). The maximum power during this time is limited to $V_{OUT} \times 2 \times$

I_{OL} where I_{OL} is the overload current limit set by the $R_{(ILIM)}$ resistor. After the $t_{CB(dly)}$ time, the output power gets limited to the value programmed by the PLIM resistor. Set the power limit using [方程式 6](#).

$$P_{(PLIM)} = 1 \times R_{(PLIM)} \quad (6)$$

Here $P_{(PLIM)}$ is output power limit in watts, $R_{(PLIM)}$ is the power limit setting resistor in $k\Omega$. [Figure 9-17](#) and [Figure 9-18](#) illustrate output power limiting performance of TPS26632 and TPS26633 devices respectively.

Refer to [图 8-2](#) for more information on $t_{CB(dly)}$ and $t_{CL_PLIM(dly)}$ parameter measurement information.



图 9-16. TPS26632, TPS26633, TPS26635 and TPS26636 Typical Application Schematic



图 9-17. 100 W Class 2, Output Power Limiting Response of TPS26632

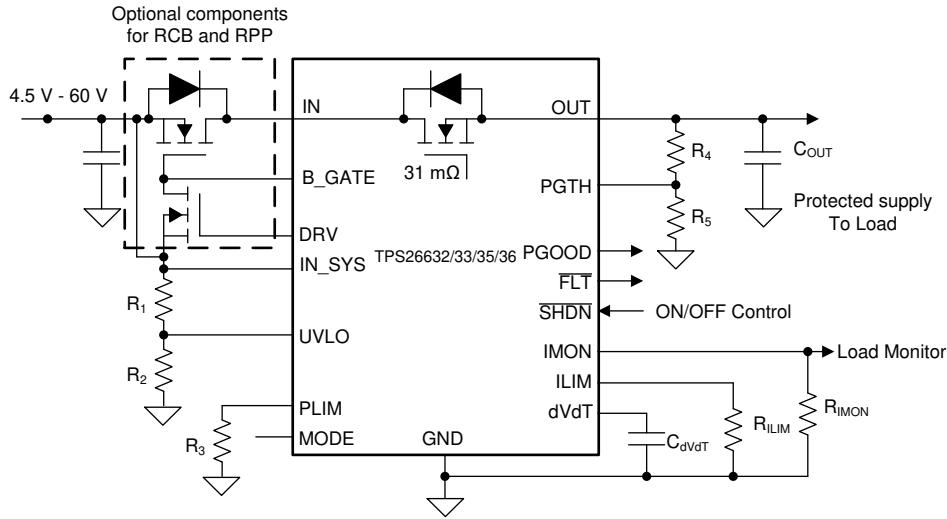

图 9-18. 100 W Class 2, Output Power Limiting Response of TPS26633

9.3.9 Current Monitoring Output (IMON)

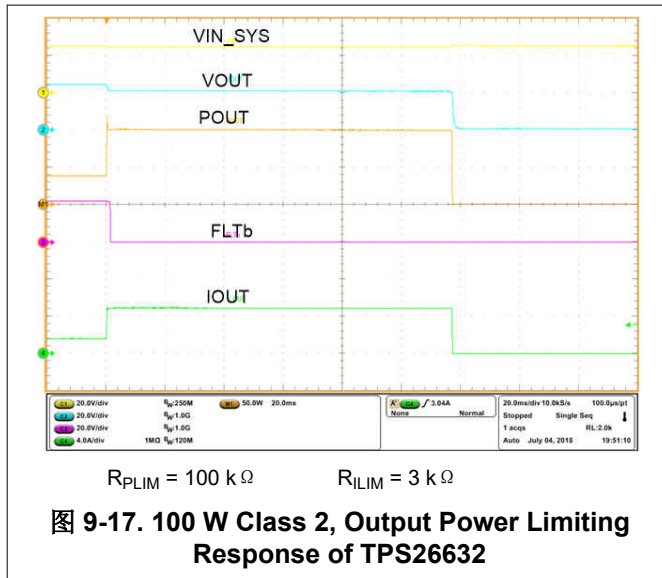
The TPS2663x devices feature an accurate analog current monitoring output. A current source at IMON terminal is internally configured to be proportional to the current flowing from IN to OUT. This current can be converted into a voltage using a resistor $R_{(IMON)}$ from IMON terminal to GND terminal. The IMON voltage can be used as a means of monitoring current flow through the system. The maximum voltage ($V_{(IMONmax)}$) for monitoring the current is limited to 4 V. This puts a limitation on maximum value of $R_{(IMON)}$ resistor and is determined by [方程式 7](#).

$$V_{(IMON)} = [I_{(OUT)} \times GAIN_{(IMON)}] \times R_{(IMON)} \quad (7)$$

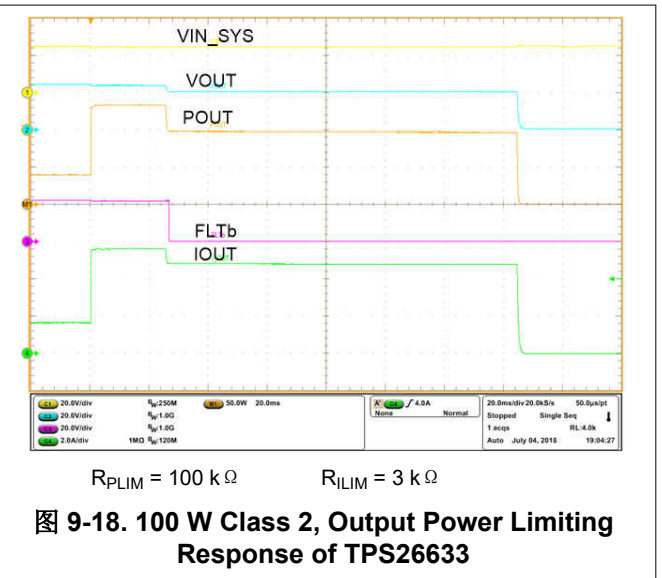
Where,

- $GAIN_{(IMON)}$ is the gain factor $I_{(IMON)}:I_{(OUT)} = 27.9 \mu A/A$ (Typical)
- $I_{(OUT)}$ is the load current

Refer to [Figure 6-13](#) for IMON output versus load current plot. [图 9-19](#) illustrates IMON performance.



图 9-19. IMON Response During a Load Step

The IMON pin must not have a bypass capacitor to avoid delay in the current monitoring information.

9.3.10 FAULT Response (\overline{FLT})

The \overline{FLT} open-drain output asserts (active low) under the faults events such as undervoltage, overvoltage, overload, power limiting, reverse current, ILIM pin short and thermal shutdown conditions. The device is designed to eliminate false reporting by using an internal "de-glitch" circuit for fault conditions without the need for an external circuitry. \overline{FLT} can be left open or connected to GND when not used.

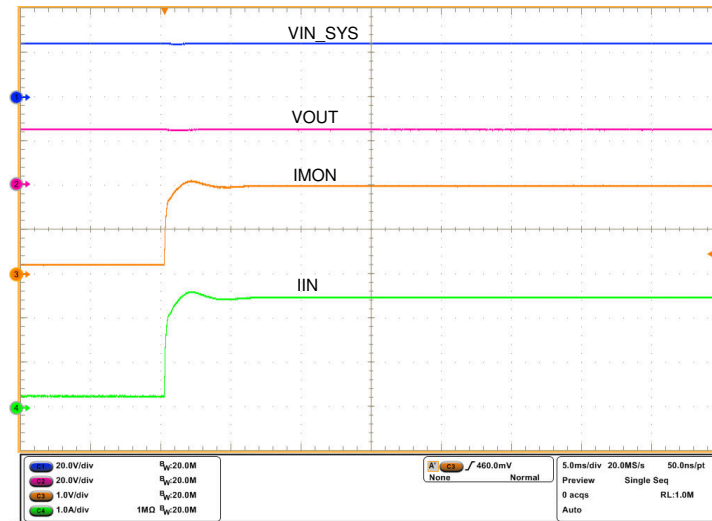
9.3.11 IN_SYS, IN, OUT and GND Pins

Connect a minimum of 0.1 μ F capacitor across IN_SYS and GND. For systems and applications where reverse polarity protection and/or reverse current blocking feature is required

- Connect a N-channel FET between IN_SYS and IN with source of the FET connected to IN_SYS, Drain at IN and GATE to B_GATE.
- Connect a N-channel signal FET with GATE to DRV, Drain to B_GATE, Source to IN_SYS

If the external N-channel FET is not used then connect IN_SYS and IN together and leave B_GATE and DRV pins floating as shown in [Figure 8-7](#). Do not leave any of the IN and OUT pins un-connected.

9.3.12 Thermal Shutdown

The device has a built-in overtemperature shutdown circuitry designed to protect the internal FET, if the junction temperature exceeds $T_{(TSD)}$, 165°C (typical). After the thermal shutdown event, depending upon the mode of fault response configured as per the [表 9-1](#), the device either latches off or commences an auto-retry cycle of 648 msec (typical), $t_{(TSD_retry)}$ after $T_J < [T_{(TSD)} - 11^\circ\text{C}]$. During the thermal shutdown, the fault pin \overline{FLT} pulls low to indicate a fault condition.

9.3.13 Low Current Shutdown Control (SHDN)

The internal, external FET and hence the load current can be switched off by pulling the $\overline{\text{SHDN}}$ pin below 0.8-V threshold with a micro-controller GPIO pin or can be controlled remotely with an opto-isolator device. The device quiescent current reduces to 21 μA (typical) in shutdown state. To assert $\overline{\text{SHDN}}$ low, the pull down must have sinking capability of at least 10 μA . To enable the device, $\overline{\text{SHDN}}$ must be pulled up to at least 2 V. Once the device is enabled, the internal FET turns on with dVdT mode. 图 9-20 and 图 9-13 illustrate the performance of SHDN control.

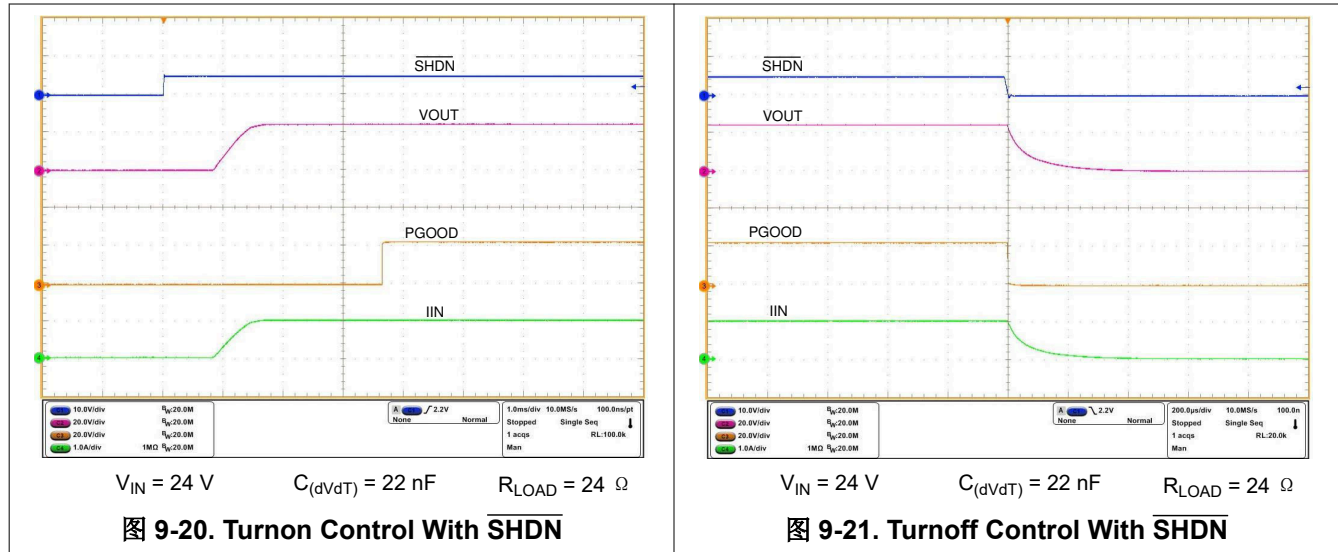

9.4 Device Functional Modes

The TPS2663x devices respond differently to overload with MODE pin configurations. The operational differences are explained in 表 9-1.

表 9-1. Device Operational Differences Under Different MODE Configurations

| MODE Pin Configuration | Overload Protection Operation | Device |
|------------------------|--|--|
| Open | Active Current limiting at 1x for a maximum duration of $t_{\text{CL_PLIM(dly)}}$. There after Latches OFF. Latch reset by toggling $\overline{\text{SHDN}}$ low to high or UVLO low to high or power cycling IN_SYS . | TPS26630, TPS26632 |
| | Active Current limiting at 2x for $t_{\text{CB(dly)}}$ duration followed with 1x current limiting for a maximum duration of $t_{\text{CL_PLIM(dly)}}$. There after Latches OFF. Latch reset by toggling $\overline{\text{SHDN}}$ low to high or UVLO low to high or power cycling IN_SYS . | TPS26631, TPS26633, TPS26635, TPS26636 |
| Shorted to GND | Active Current limiting at 1x for a maximum duration of $t_{\text{CL_PLIM(dly)}}$. There after auto-retries after a delay of $t_{\text{(TSD_retry)}}$. | TPS26630, TPS26632 |
| | Active Current limiting at 2x for $t_{\text{CB(dly)}}$ duration followed with 1x current limiting for a maximum duration of $t_{\text{CL_PLIM(dly)}}$. There after auto-retries after a delay of $t_{\text{(TSD_retry)}}$. | TPS26631, TPS26633, TPS26635 |

Refer to 图 8-2 for more information on $t_{\text{CB(dly)}}$ and $t_{\text{CL_PLIM(dly)}}$ parameter measurement information.

10 Application and Implementation

备注

以下应用部分中的信息不属于 TI 器件规格的范围，TI 不担保其准确性和完整性。TI 的客户应负责确定器件是否适用于其应用。客户应验证并测试其设计，以确保系统功能。

10.1 Application Information

The TPS2663x is an industrial eFuse, typically used for Hot-Swap and Power rail protection applications. It operates from 4.5 V to 60 V with adjustable current limit, output power limit, overvoltage, undervoltage and reverse polarity protections. The device aids in controlling in-rush current and provides robust protection against reverse current and filed miss-wiring conditions for systems such as PLCs, Industrial PCs, Control and Automation and Sensors. The device also provides robust protection for multiple faults on the system rail

The [Detailed Design Procedure](#) section can be used to select component values for the device. Additionally, a spreadsheet design tool [TPS2663 Design Calculator](#) is available in the web product folder.

10.2 Typical Application: Power Path Protection in a PLC System



图 10-1. A Typical CPU (PLC Controller) System Block Diagram

The PLC system is usually connected to an external 24-V DC power supply to provide power to the controller unit, backplane, and I/O modules. Input protection circuits are required to protect the PLC from faults such as overvoltage, undervoltage, and overload. Because input supply connectors are screw type, there can always be a possibility of reverse supply connections. Protection circuits should block the reverse polarity to protect the PLC from possible negative voltages. At the same time, every PLC is tested for electrostatic discharge (ESD) according to IEC 61000-4-2, burst pulses (EFT) according to IEC 61000- 4-4, energy single pulse (surge)

according to IEC 61000-4-5, voltage drops and interruptions. 图 10-1 shows a system block diagram of PLC controller unit along with the input protection socket. The TPS2663x devices offer a plug and play input protection solution for such applications. For more information about this end equipment refer to the TI application site on [Programmable Logic Controller \(PLC\), DCS & PAC: CPU \(PLC Controller\)](#).

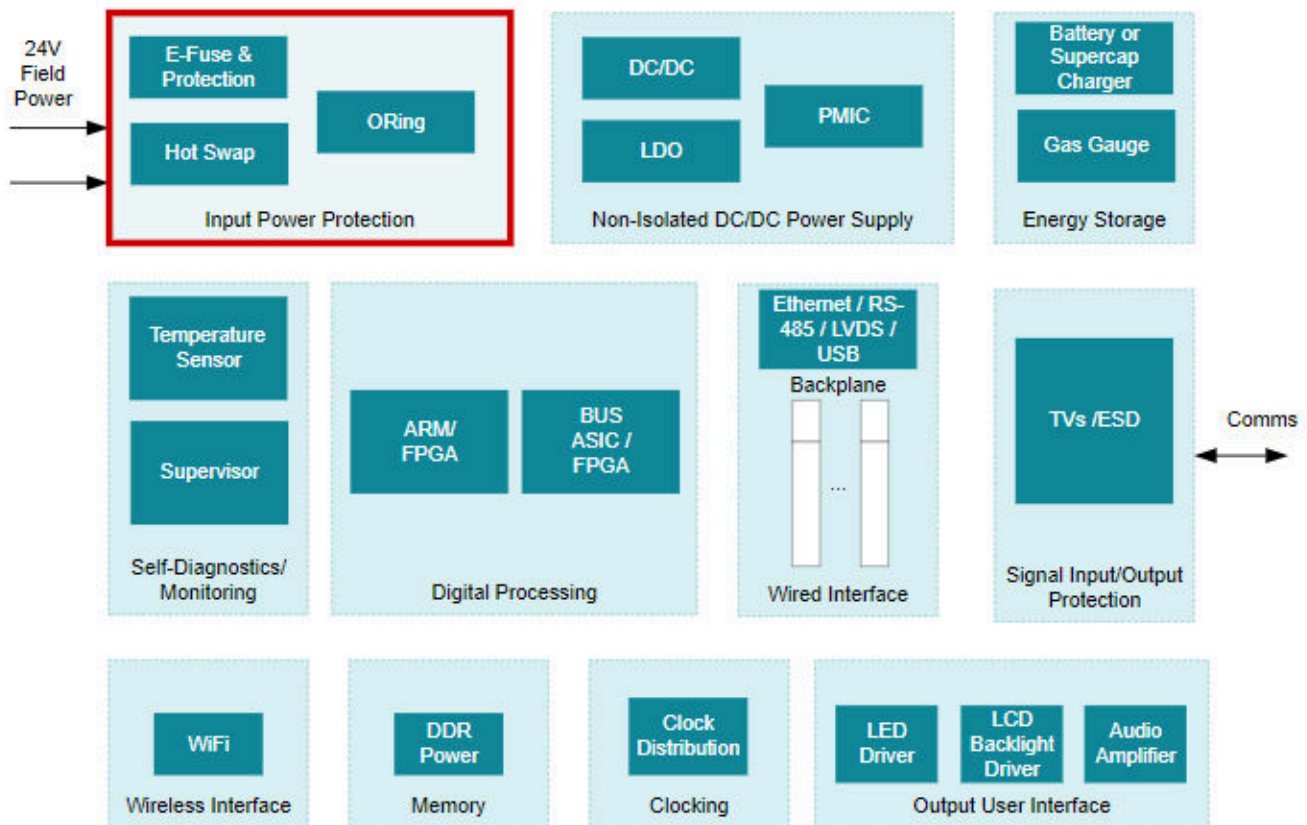

图 10-2. 24-V, 2-A eFuse Input Protection Circuit for Industrial PLC, CNC CPU

10.2.1 Design Requirements

表 10-1 shows the Design Requirements for TPS2663x.

表 10-1. Design Requirements

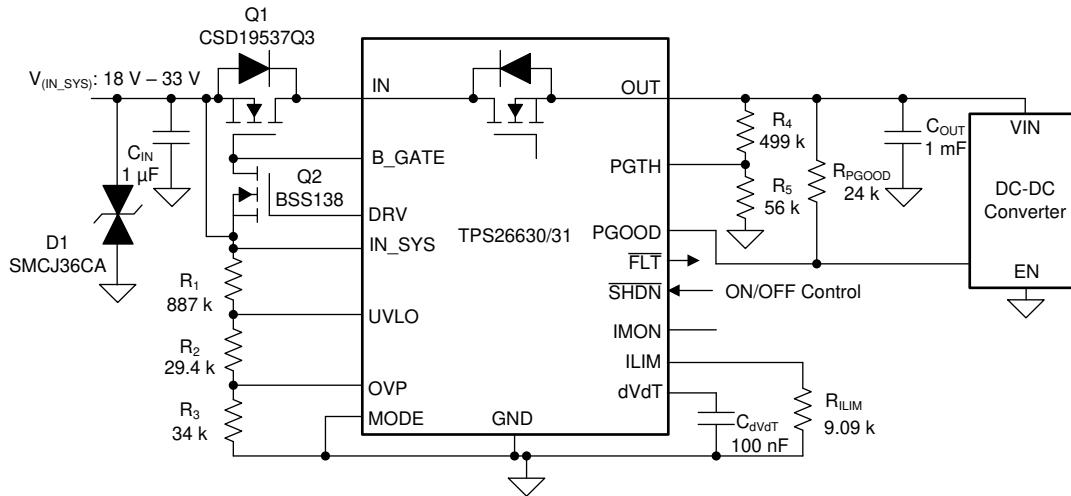
| DESIGN PARAMETER | | EXAMPLE VALUE |
|------------------|--------------------------------|---|
| $V_{(IN)}$ | Typical input voltage | 24 V |
| $V_{(UV)}$ | Undervoltage lockout set point | 18 V |
| $V_{(OV)}$ | Overvoltage cutoff set point | 33 V |
| $I_{(LIM)}$ | Overload Current limit | 2 A |
| $I_{(INRUSH)}$ | Inrush Current limit | 500 mA |
| $P_{(OUT)}$ | Output Load | 15 W (DC-DC) with 15 V $V_{INminDC-DC}$ |
| $T_{(FAIL_TR)}$ | Power Interruption time | 10 msec |
| $P_{(Surge)}$ | IEC61000-4-5 Surge test level | ± 500 V, 2 Ω generator impedance |

10.2.2 Detailed Design Procedure

10.2.2.1 Programming the Current-Limit Threshold— $R_{(ILIM)}$ Selection

The $R_{(ILIM)}$ resistor at the ILIM pin sets the overload current limit, this can be set using 方程式 8.

$$R_{(ILIM)} = \frac{18}{I_{OL}} = 9k\Omega \quad (8)$$

where

- $I_{LIM} = 2$ A

Choose the closest standard 1% resistor value : $R_{(ILIM)} = 9.09$ k Ω

10.2.2.2 Undervoltage Lockout and Overvoltage Set Point

The undervoltage lockout (UVLO) and overvoltage trip point are adjusted using an external voltage divider network of R_1 , R_2 and R_3 connected between IN_SYS, UVLO, OVP and GND pins of the device. The values required for setting the undervoltage and overvoltage are calculated by solving 方程式 9 and 方程式 10.

$$V_{(OVPR)} = \frac{R_3}{R_1 + R_2 + R_3} \times V_{(OV)} \quad (9)$$

$$V_{(UVLOR)} = \frac{R_2 + R_3}{R_1 + R_2 + R_3} \times V_{(UV)} \quad (10)$$

For minimizing the input current drawn from the power supply $\{I_{(R123)} = V_{(IN)} / (R_1 + R_2 + R_3)\}$, it is recommended to use higher value resistance for R_1 , R_2 and R_3 .

However, the leakage current due to external active components connected at resistor string can add error to these calculations. So, the resistor string current, $I_{(R123)}$ must be chosen to be 20x greater than the leakage current of UVLO and OVP pins.

From the device electrical specifications, $V_{(OVPR)} = 1.2$ V and $V_{(UVLOR)} = 1.2$ V. From the design requirements, $V_{(OV)}$ is 33 V and $V_{(UV)}$ is 18 V. To solve the equation, first choose the value of $R_3 = 34$ k Ω and use 方程式 9 to solve for $(R_1 + R_2) = 916$ k Ω . Use 方程式 10 and value of $(R_1 + R_2)$ to solve for $R_2 = 29.4$ k Ω and finally $R_1 = 887$ k Ω .

Choose the closest standard 1% resistor values: $R_1 = 887$ k Ω , $R_2 = 29.4$ k Ω , and $R_3 = 34$ k Ω .

The UVLO and the OVP pins can also be connected to the GND pin to enable the internal default $V_{(OV)} = 34.2$ V and $V_{(UV)} = 15.6$ V.

10.2.2.3 Output Buffer Capacitor - C_{OUT}

During the power interruption time T_{FAIL_TR} the output capacitor C_{OUT} of the TPS26630 provides energy to the 15 W DC-DC converter load. Use 方程式 11 to compute the required buffer capacitor C_{OUT}

$$C_{OUT} = \frac{2 \times P_{(DC-DC)} \times T_{FAIL_TR}}{V_{(IN_SYS)}^2 - V_{(UV_DC-DC)}^2} \quad (11)$$

where

- $P_{(DC-DC)} = 15$ W / η . Assuming efficiency of 95%, $P_{(DC-DC)} = 15.8$ W
- $T_{FAIL_TR} = 10$ msec
- $V_{(IN_SYS)} = 24$ V
- $V_{(UV_DC-DC)} = 15$ V

$C_{OUT} = 0.9$ mF. Choose a capacitor with $\pm 10\%$ tolerance, $C_{OUT} = 1$ mF/35 V electrolytic capacitor. Figure 9-4 and 图 10-5 illustrate the performance during the power interruption tests on TPS26630. Figure 9-8 illustrate the performance on TPS26631.

10.2.2.4 PGTH Set Point

Set the V_{PGTHF} threshold at the down-stream DC-DC converter UVLO falling threshold. VIN minimum operating voltage of the DC-DC converter is at 15 V. Assuming UVLO to be at 20% lower level, $V_{UVLO_DC-DC} = 12$ V. Use 方程式 12 to calculate R_4 and R_5 .

$$V_{(PGTHF)} = \frac{R_5}{R_4 + R_5} \times V_{UVLO_DC-DC} \quad (12)$$

$V_{(PGTHF)} = 1.14 \text{ V}$. Assuming $R_5 = 56 \text{ k}\Omega$, R_4 comes out to be approximately $499 \text{ k}\Omega$.

10.2.2.5 Setting Output Voltage Ramp Time—(t_{dVdT})

Use 方程式 1 and 方程式 2 to calculate required $C_{(dVdT)}$ for achieving an inrush current of 500 mA . $C_{(dVdT)} = 0.1 \mu\text{F}$. Figure 9-3 illustrates the inrush current limiting performance during 24-V hot-plug in condition.

10.2.2.5.1 Support Component Selections— R_{PGOOD} and $C_{(IN)}$

The R_{PGOOD} serves as pull-up for the open-drain output. The current sink by this pin must not exceed 10 mA (see the *Absolute Maximum Ratings* table). Typical resistance value in the range of $10 \text{ k}\Omega$ to $100 \text{ k}\Omega$ is recommended for R_{PGOOD} . Connect PGOOD directly to the EN pin of the DC-DC converter. 图 10-6 and Figure 9-8 illustrate the power up and power down performance of the system respectively. The C_{IN} is a local bypass capacitor to suppress noise at the input. A minimum of $1 \mu\text{F}$ is recommended for $C_{(IN)}$ for limit the slew rates during the surge test.

10.2.2.6 Selecting Q1, Q2 and TVS Clamp for Surge Protection

For $\pm 500\text{-V}$, $2\text{-}\Omega$ surge, typically a SMC sized TVS like SMCJ36CA clamps the voltage around $\pm 55 \text{ V}$. During the negative surge strike, the input voltage V_{IN_SYS} spikes to -55 V . This results in a voltage stress of $-(55 \text{ V} + 24 \text{ V}) = -79 \text{ V}$ across the external blocking FET Q1. Choose at least a 80-V rated N-channel FET. B_GATE drive is in the range of 10 V to 14 V . Select a suitable FET with the target $R_{DS(on)}$ specified at this gate drive voltage. The fast pull down gate switch Q2 pulls down the GATE of the Q1 during the reverse current event appearing during the surge test. Q2 should be at least 15-V VDS rated FET with a maximum VGS rating of 20-V , $C_{iss} \leq 50 \text{ pF}$ and $V_{GTH(min)} \leq 3 \text{ V}$. CSD19537Q3 and BSS138 are selected for Q1 and Q2 respectively. Figure 9-9 and Figure 9-10 illustrate the performance of the system during the surge testing.

10.2.3 Application Curves

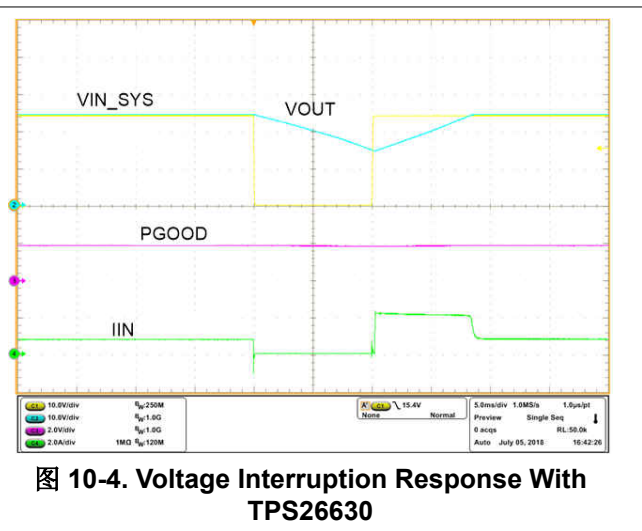
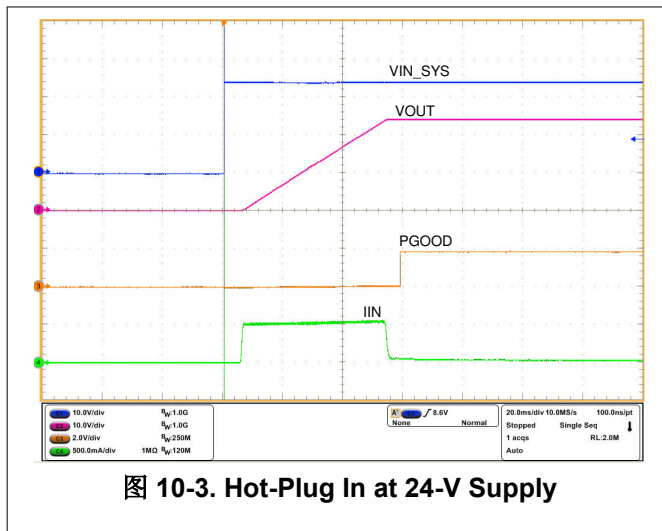



图 10-5. Voltage Interruption Response With TPS26630 (Zoomed)



图 10-6. Power Up Followed With Voltage Interruption With TPS26630

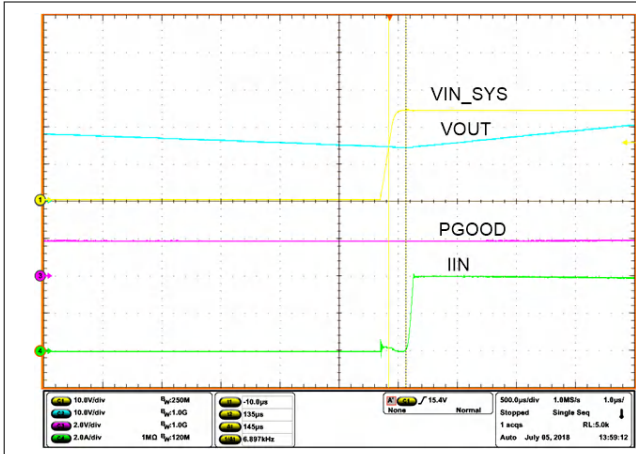

图 10-7. Voltage Interruption Performance With TPS26631

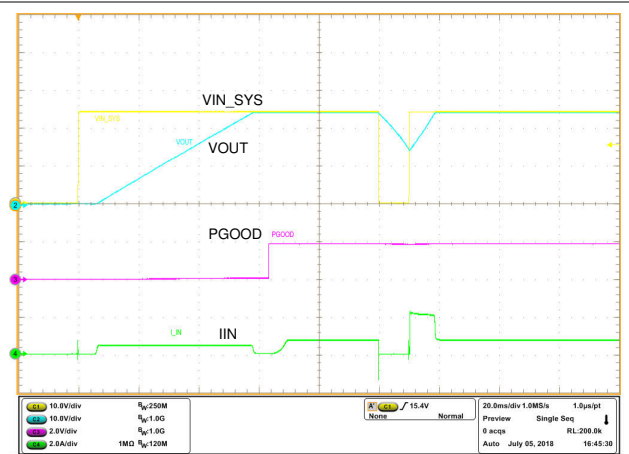

图 10-8. Power Down Response

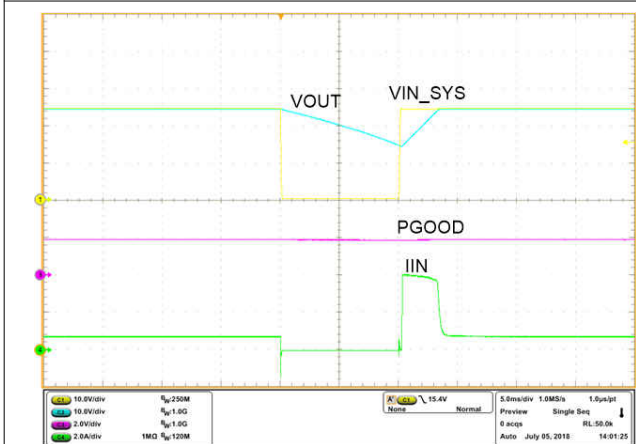

图 10-9. 500-V, 2-Ω Surge Response

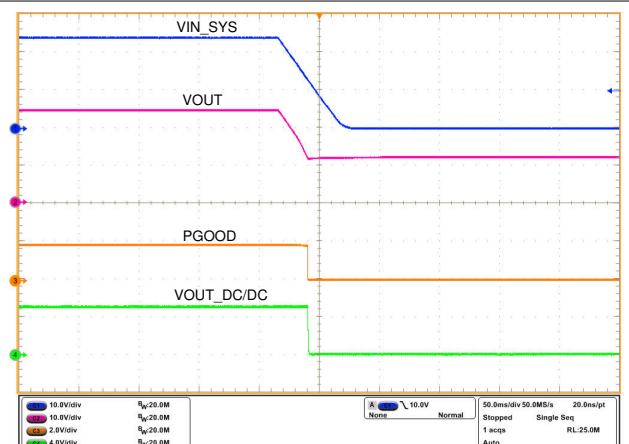

图 10-10. -500-V, 2-Ω Surge Response

10.3 System Examples

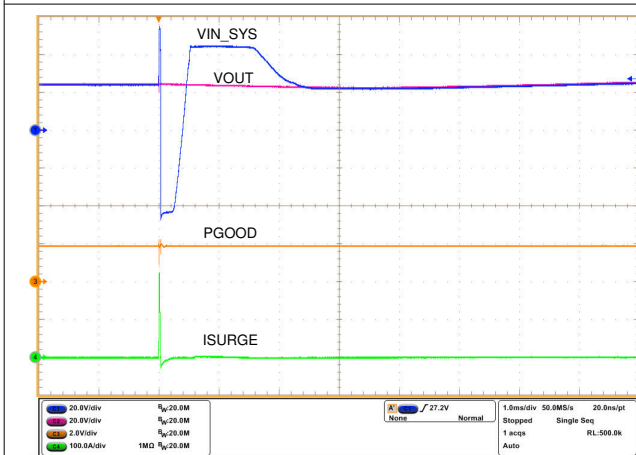
10.3.1 Simple 24-V Power Supply Path Protection

With the TPS2663x devices, a simple 24-V power supply path protection can be realized using a minimum of five external components as shown in the schematic diagram in 图 10-11. The external components required are: a N - Channel Power FET Q₁, a N - Channel signal FET Q₂ and a R_(ILIM) resistor to program the current limit, C_(IN) and C_(OUT) capacitors.

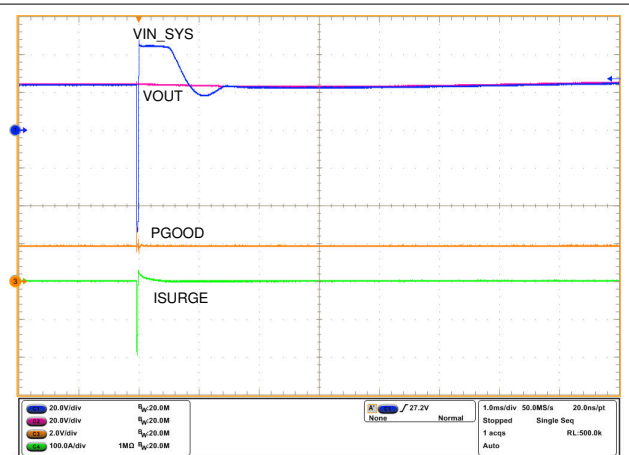

图 10-11. TPS26630 Configured for a Simple 24-V Supply Path Protection

Protection features with this configuration include:

- Load and device protection from reverse input polarity fault down to - 60 V (with a 60-V rated Q₁)
- Overvoltage Protection at 34 V
- Inrush current control with 24-V/240-μs output voltage slew rate
- Reverse Current Blocking
- Accurate current limiting with Auto-Retry

10.3.2 Priority Power MUX Operation

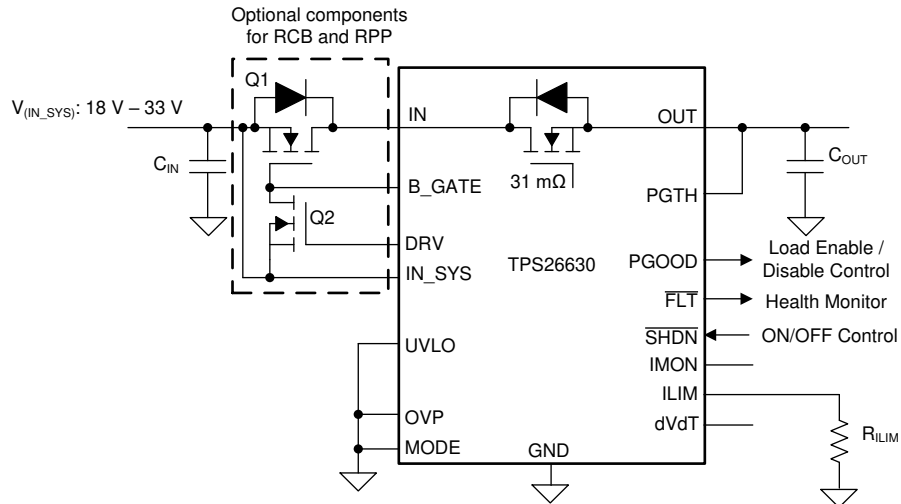
Applications having two energy sources such as Portable battery powered equipment require preference of one source to another. For example, mains power (wall-adapter) has the priority over the internal back-up power or auxiliary power. These applications demand for switch over from mains power to backup power only when main input voltage falls below a user defined threshold. The TPS2663x devices provide a simple solution for priority power multiplexing needs.

图 10-12 shows a typical priority power multiplexing implementation using devices. When the MAIN power is present, the device in VIN_MAIN path powers the OUT bus irrespective of whether auxiliary power VIN_AUX is greater than or less than VIN_MAIN. Once the voltage on the VIN_MAIN rail falls below the user-defined threshold, the device VIN_MAIN issues a signal to switch over to auxiliary power VIN_AUX. The transition happens seamlessly in t_{OVP(dly_fast)}, with minimal voltage droop on the output. The voltage droop during transition is a function of load current and output capacitance. See 方程式 13.

$$V_{(\text{DROOP})} = \frac{I_{(\text{LOAD})} \times t_{\text{OVP}(\text{fast_dly})}}{C_{(\text{OUT})}} \quad (13)$$

where

- V_(DROOP) is in volts, I_(LOAD) is load current in Ampere, C_(OUT) is output capacitance in μF, t_{OVP(fast_dly)} = 140 μs (typical)

TPS2663

ZHCSIU6F - SEPTEMBER 2018 - REVISED JUNE 2021

Figure 9-13, Figure 9-14, Figure 9-15 and figure 9-16 show typical switch-over waveforms of Priority Muxing implementation using the TPS26630 or TPS26631 for 20-V Primary and 24-V Auxiliary Bus.



图 10-12. Priority Power Mux Implementation



图 10-13. VIN_MAIN Power Recovery: Change Over from Auxiliary VIN_AUX to Primary Power VIN_MAIN

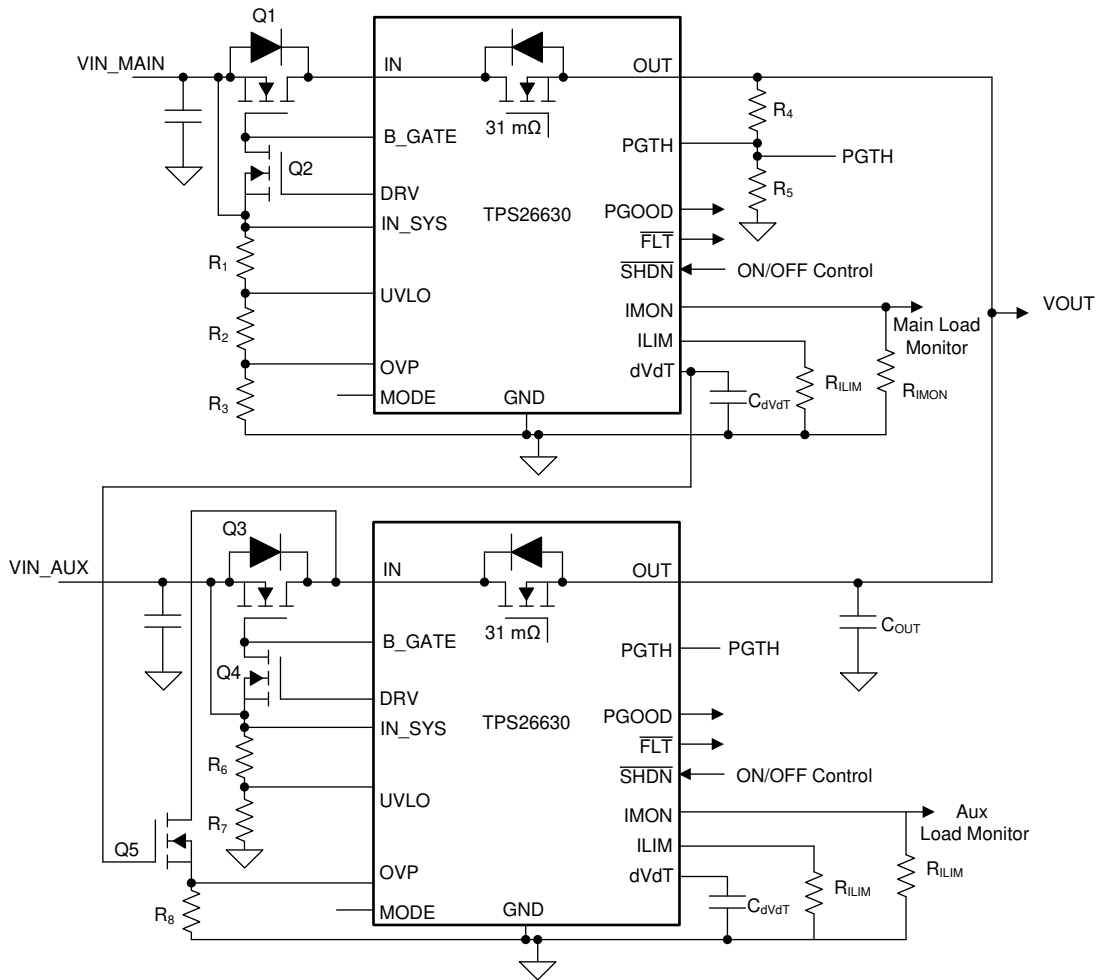

图 10-14. VIN_MAIN Brownout Condition: Change Over from Main VIN_MAIN to Auxiliary Power VIN_AUX

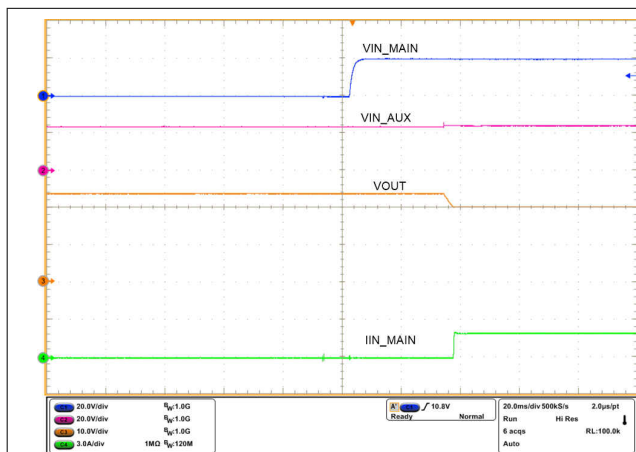

图 10-15. VIN_AUX Brownout Condition

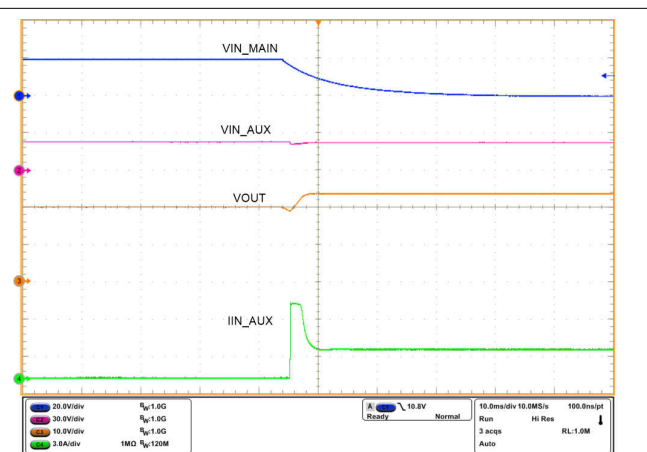

图 10-16. VIN_AUX Power Recovery

10.3.3 Input Protection for a Compact 24-V Auxiliary Power Supply for Servo Drives

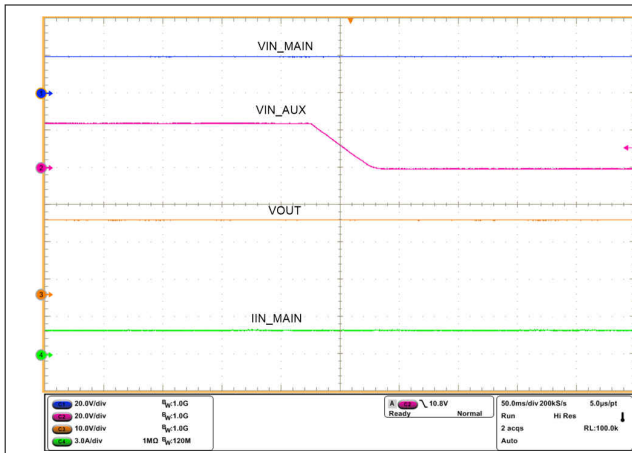
TPS2663x eFuse protects the system from common faults such as reverse polarity, reverse power flow, overvoltage, undervoltage and overcurrents along with a robust EMC immunity performance. Refer to, [Compact, efficient, 24-V input auxiliary power supply reference design for servo drives](#) TI Design Guide for further information.

10.4 Do's and Don'ts

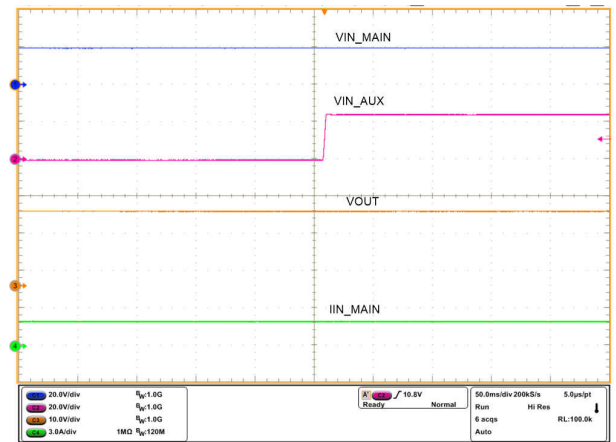
- In the applications where reverse polarity protection is required use external FETs Q1 and Q2.
- Connect at least a 300-k Ω resistor across UVLO and IN_SYS in the applications where reverse polarity protection is required.

11 Power Supply Recommendations

The TPS2663x eFuse is designed for the supply voltage range of $4.5\text{ V} \leq V_{IN} \leq 60\text{ V}$. If the input supply is located more than a few inches from the device, an input ceramic bypass capacitor higher than 0.1 μF is recommended. Power supply must be rated higher than the current limit set to avoid voltage droops during overcurrent and short circuit conditions.

11.1 Transient Protection

In case of short circuit and overload current limit, when the device interrupts current flow, input inductance generates a positive voltage spike on the input and output inductance generates a negative voltage spike on the output. The peak amplitude of voltage spikes (transients) depends on the value of inductance in series to the input or output of the device. These transients can exceed the [Absolute Maximum Ratings](#) of the device if steps are not taken to address the issue.

Typical methods for addressing transients include:

- Minimizing lead length and inductance into and out of the device
- Using large PCB GND plane
- Use of a Schottky diode across the output and GND to absorb negative spikes
- A low value ceramic capacitor ($C_{(IN)}$) to approximately 0.1 μF to absorb the energy and dampen the transients.

The approximate value of input capacitance can be estimated with [方程式 14](#)

$$V_{\text{spike(Absolute)}} = V_{(IN)} + I_{(\text{Load})} \times \sqrt{\frac{L_{(IN)}}{C_{(IN)}}} \quad (14)$$

where

- $V_{(IN)}$ is the nominal supply voltage
- $I_{(LOAD)}$ is the load current
- $L_{(IN)}$ equals the effective inductance seen looking into the source
- $C_{(IN)}$ is the capacitance present at the input

Some applications may require additional Transient Voltage Suppressor (TVS) to prevent transients from exceeding the *Absolute Maximum Ratings* of the device. These transients can occur during positive and negative surge tests on the supply lines. In such applications it is recommended to place at least 1 μF of input capacitor.

The circuit implementation with optional protection components (a ceramic capacitor, TVS and schottky diode) is shown in [Figure 10-1](#).

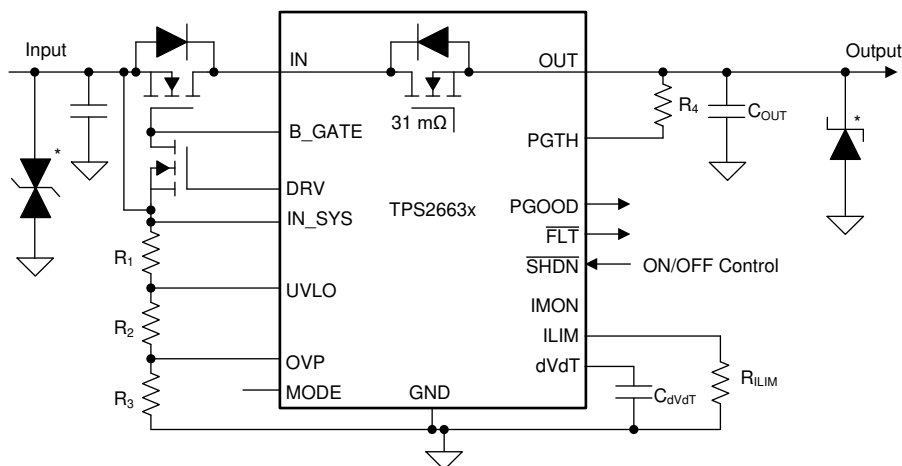

* Optional components needed for suppression of transients

图 11-1. Circuit Implementation with Optional Protection Components for TPS2663x

12 Layout

12.1 Layout Guidelines

- For all the applications, a 0.1 μF or higher value ceramic decoupling capacitor is recommended between IN_SYS terminal and GND.
- The external FET Q1 should be placed with DRAIN close to the V_{IN} pins of the IC and connected through a plane. The fast pull down switch Q2 DRAIN and SOURCE should be placed very close to the GATE and SOURCE terminals of Q1 with very short loop. See [Figure 12-1](#) and [Figure 12-2](#) for a typical PCB layout example.
- The optimum placement of decoupling capacitor is closest to the IN_SYS and GND terminals of the device. Care must be taken to minimize the loop area formed by the bypass-capacitor connection, the IN_SYS terminal, and the GND terminal of the IC.
- High current carrying power path connections must be as short as possible and must be sized to carry at least twice the full-load current.
- Locate all the TPS2663x family support components $R_{(\text{ILIM})}$, $C_{(\text{dVdT})}$, $R_{(\text{IMON})}$, UVLO, OVP and PGTH resistors close to their connection pin. Connect the other end of the component to the GND with shortest trace length.
- The trace routing for the R_{ILIM} component to the device must be as short as possible to reduce parasitic effects on the current limit and current monitoring accuracy. These traces must not have any coupling to switching signals on the board.
- Protection devices such as TVS, snubbers, capacitors, or diodes must be placed physically close to the device they are intended to protect, and routed with short traces to reduce inductance. For example, a protection Schottky diode is recommended to address negative transients due to switching of inductive loads, and it must be physically close to the OUT and GND pins.
- Thermal Considerations: When properly mounted, the PowerPAD package provides significantly greater cooling ability. To operate at rated power, the PowerPAD must be soldered directly to the board GND plane directly under the device. Other planes, such as the bottom side of the circuit board can be used to increase heat sinking in higher current applications.

12.2 Layout Example

- Top Layer
- Bottom layer GND plane
- Top Layer GND Plane
- Via to Bottom Layer



图 12-1. Typical PCB Layout Example With QFN Package With a 2 Layer PCB

- Top Layer
- Bottom layer GND plane
- Top Layer GND Plane
- Via to Bottom Layer

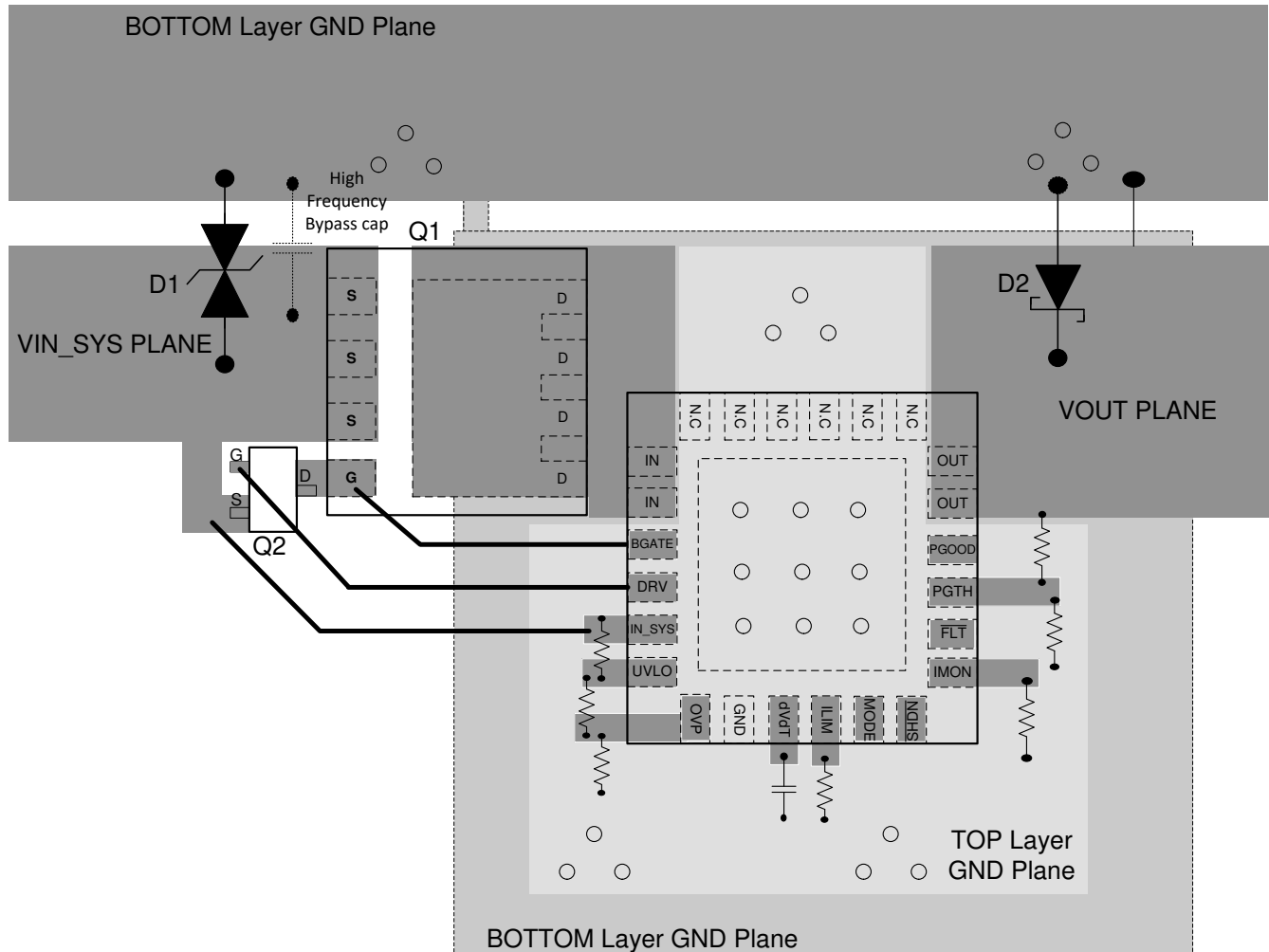

图 12-2. Typical PCB Layout Example With HTSSOP Package With a 2 Layer PCB

13 Device and Documentation Support

13.1 Documentation Support

13.1.1 Related Documentation

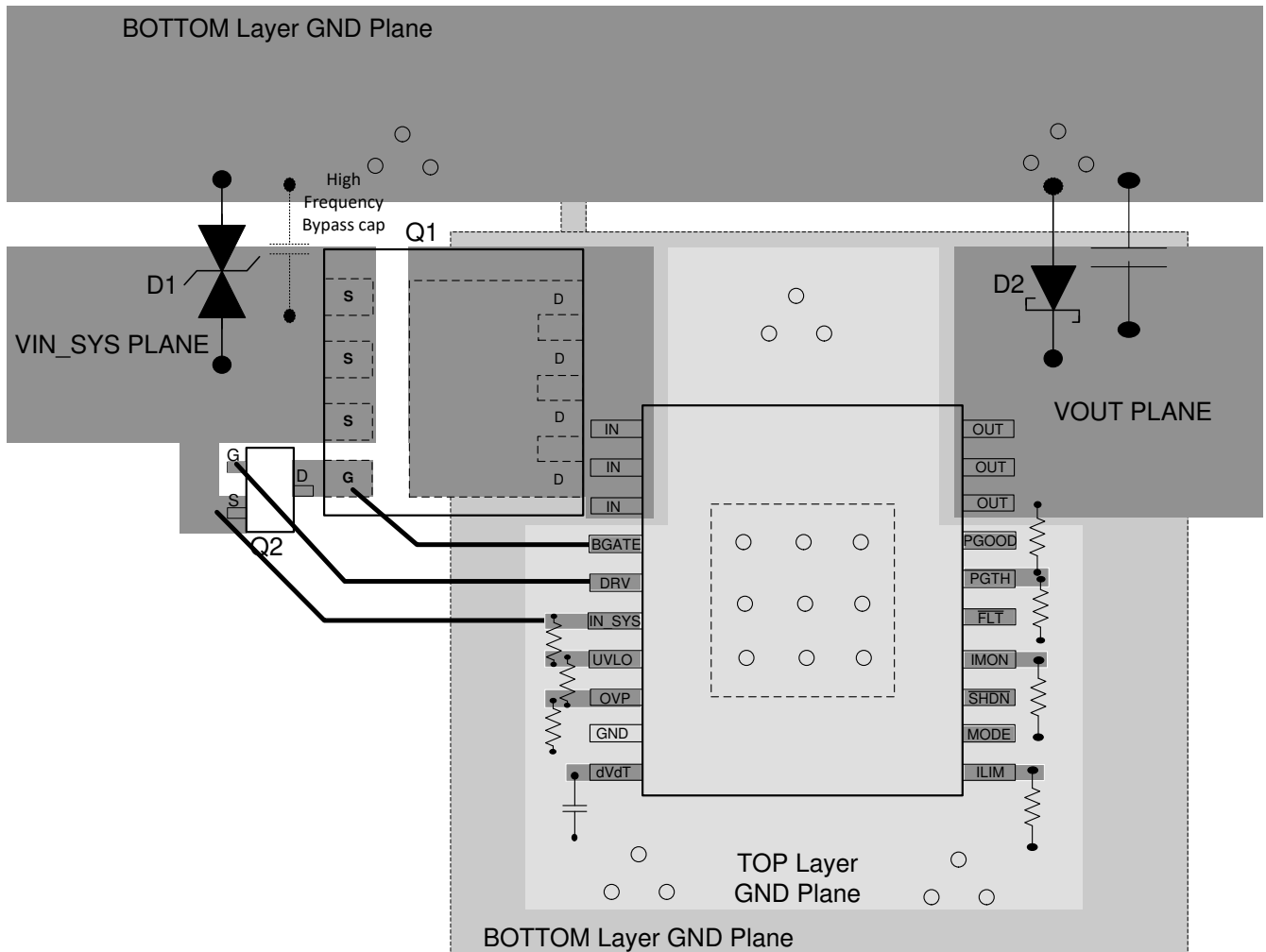
- [TPS2663 Design Calculator](#)
- [CPU \(PLC Controller\)](#)
- [Compact, efficient, 24-V input auxiliary power supply reference design for servo drives](#)

13.2 接收文档更新通知

要接收文档更新通知，请导航至 ti.com 上的器件产品文件夹。点击 [订阅更新](#) 进行注册，即可每周接收产品信息更改摘要。有关更改的详细信息，请查看任何已修订文档中包含的修订历史记录。

13.3 支持资源

TI E2E™ 支持论坛是工程师的重要参考资料，可直接从专家获得快速、经过验证的解答和设计帮助。搜索现有解答或提出自己的问题可获得所需的快速设计帮助。

链接的内容由各个贡献者“按原样”提供。这些内容并不构成 TI 技术规范，并且不一定反映 TI 的观点；请参阅 TI 的《使用条款》。

13.4 Trademarks

TI E2E™ is a trademark of Texas Instruments.

所有商标均为其各自所有者的财产。

13.5 Electrostatic Discharge Caution



This integrated circuit can be damaged by ESD. Texas Instruments recommends that all integrated circuits be handled with appropriate precautions. Failure to observe proper handling and installation procedures can cause damage.

ESD damage can range from subtle performance degradation to complete device failure. Precision integrated circuits may be more susceptible to damage because very small parametric changes could cause the device not to meet its published specifications.

13.6 术语表

[TI 术语表](#) 本术语表列出并解释了术语、首字母缩略词和定义。

14 Mechanical, Packaging, and Orderable Information

The following pages include mechanical, packaging, and orderable information. This information is the most current data available for the designated devices. This data is subject to change without notice and revision of this document. For browser-based versions of this data sheet, refer to the left-hand navigation.

重要声明和免责声明

TI 提供技术和可靠性数据 (包括数据表)、设计资源 (包括参考设计)、应用或其他设计建议、网络工具、安全信息和其他资源, 不保证没有瑕疵且不做任何明示或暗示的担保, 包括但不限于对适销性、某特定用途方面的适用性或不侵犯任何第三方知识产权的暗示担保。

这些资源可供使用 TI 产品进行设计的熟练开发人员使用。您将自行承担以下全部责任: (1) 针对您的应用选择合适的 TI 产品, (2) 设计、验证并测试您的应用, (3) 确保您的应用满足相应标准以及任何其他安全、安保或其他要求。这些资源如有变更, 恕不另行通知。TI 授权您仅可将这些资源用于研发本资源所述的 TI 产品的应用。严禁对这些资源进行其他复制或展示。您无权使用任何其他 TI 知识产权或任何第三方知识产权。您应全额赔偿因在这些资源的使用中对 TI 及其代表造成的任何索赔、损害、成本、损失和债务, TI 对此概不负责。

TI 提供的产品受 TI 的销售条款 (<https://www.ti.com/legal/termsofsale.html>) 或 [ti.com](https://www.ti.com) 上其他适用条款/TI 产品随附的其他适用条款的约束。TI 提供这些资源并不会扩展或以其他方式更改 TI 针对 TI 产品发布的适用的担保或担保免责声明。

邮寄地址: Texas Instruments, Post Office Box 655303, Dallas, Texas 75265

Copyright © 2021, 德州仪器 (TI) 公司

MECHANICAL DATA

PWP (R-PDSO-G20)

PowerPAD™ PLASTIC SMALL OUTLINE

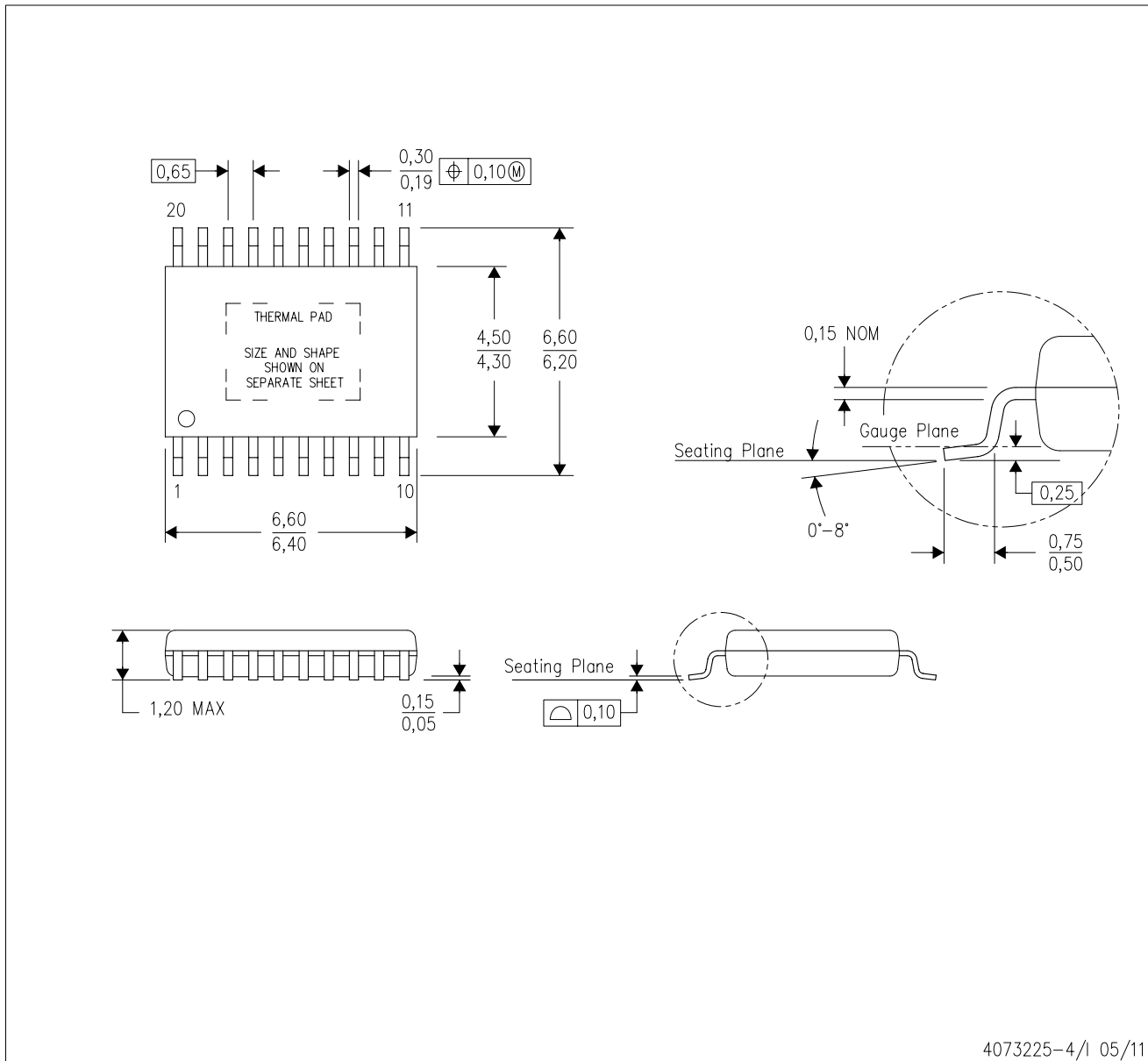

4073225-4/1 05/11

- NOTES:
- All linear dimensions are in millimeters.
 - This drawing is subject to change without notice.
 - Body dimensions do not include mold flash or protrusions. Mold flash and protrusion shall not exceed 0.15 per side.
 - This package is designed to be soldered to a thermal pad on the board. Refer to Technical Brief, PowerPad Thermally Enhanced Package, Texas Instruments Literature No. SLMA002 for information regarding recommended board layout. This document is available at www.ti.com <<http://www.ti.com>>.
 - See the additional figure in the Product Data Sheet for details regarding the exposed thermal pad features and dimensions.
 - Falls within JEDEC MO-153

PowerPAD is a trademark of Texas Instruments.

PWP0020T

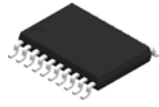

PACKAGE OUTLINE

PowerPAD™ TSSOP - 1.2 mm max height

SMALL OUTLINE PACKAGE

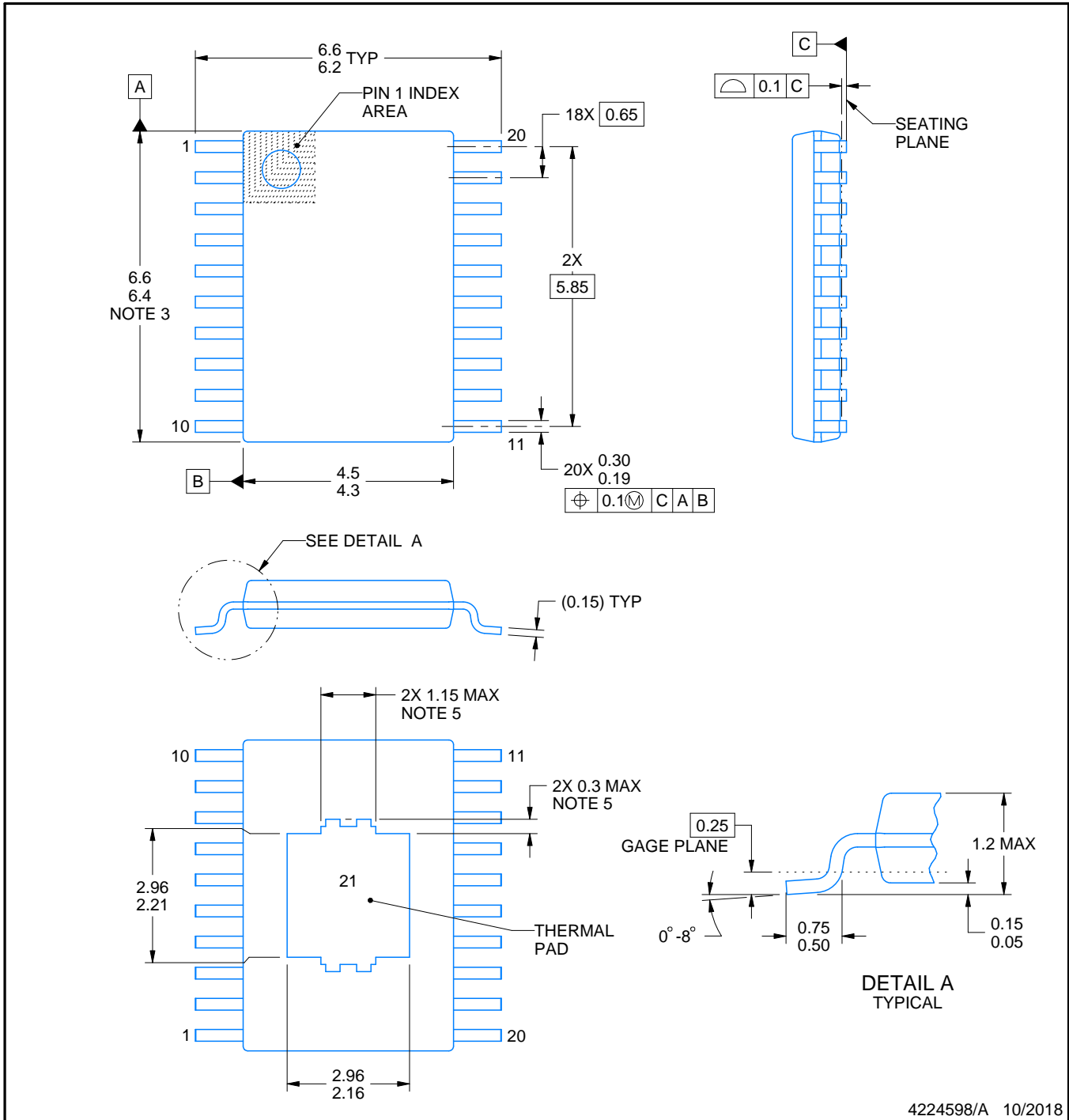

4224598/A 10/2018

PowerPAD is a trademark of Texas Instruments.

NOTES:

1. All linear dimensions are in millimeters. Any dimensions in parenthesis are for reference only. Dimensioning and tolerancing per ASME Y14.5M.
2. This drawing is subject to change without notice.
3. This dimension does not include mold flash, protrusions, or gate burrs. Mold flash, protrusions, or gate burrs shall not exceed 0.15 mm per side.
4. Reference JEDEC registration MO-153.
5. Features may differ or may not be present.

EXAMPLE BOARD LAYOUT

PWP0020T

PowerPAD™ TSSOP - 1.2 mm max height

SMALL OUTLINE PACKAGE

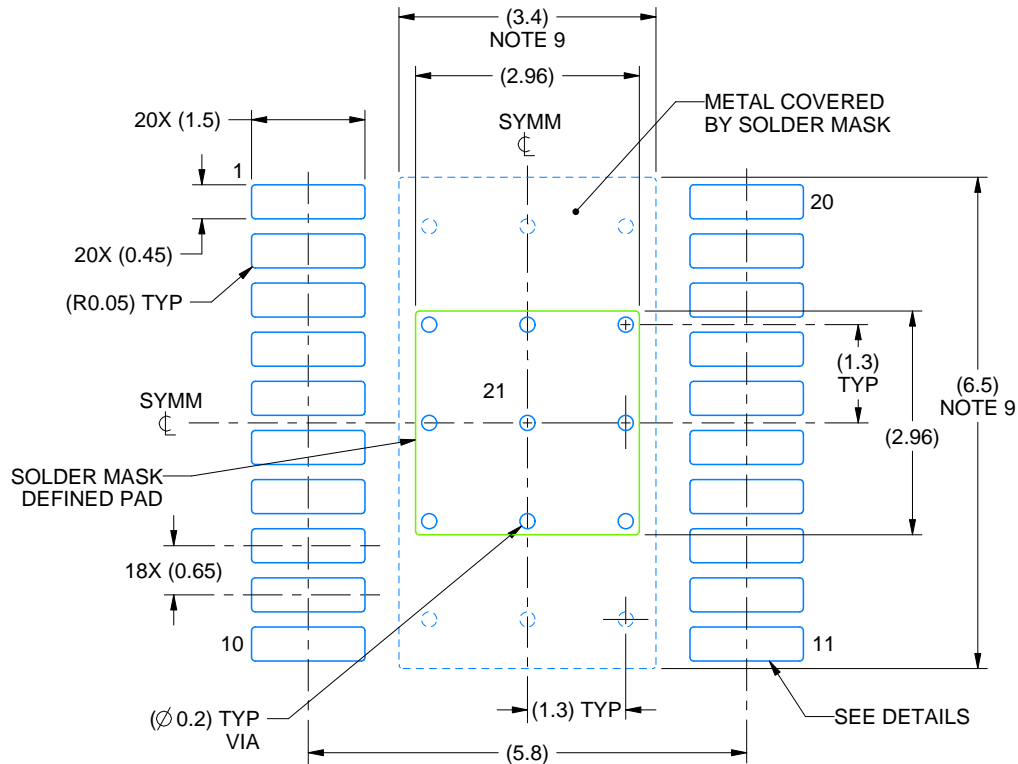

LAND PATTERN EXAMPLE
EXPOSED METAL SHOWN
SCALE: 10X

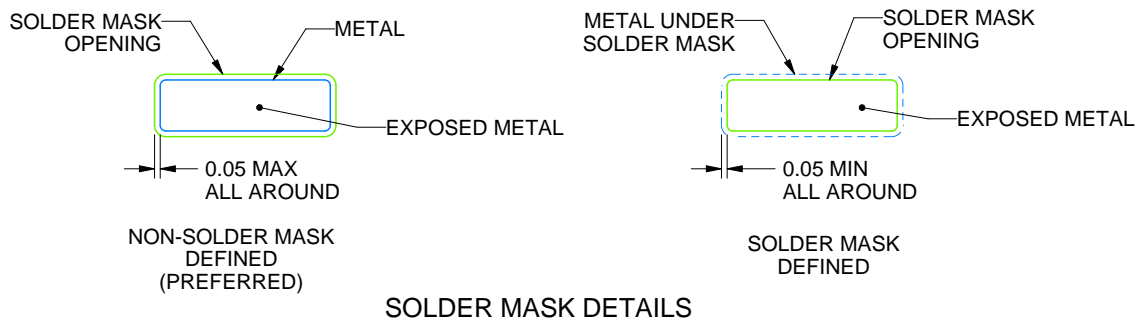

SOLDER MASK DETAILS

4224598/A 10/2018

NOTES: (continued)

6. Publication IPC-7351 may have alternate designs.
7. Solder mask tolerances between and around signal pads can vary based on board fabrication site.
8. This package is designed to be soldered to a thermal pad on the board. For more information, see Texas Instruments literature numbers SLMA002 (www.ti.com/lit/slma002) and SLMA004 (www.ti.com/lit/slma004).
9. Size of metal pad may vary due to creepage requirement.
10. Vias are optional depending on application, refer to device data sheet. It is recommended that vias under paste be filled, plugged or tented.

EXAMPLE STENCIL DESIGN

PWP0020T

PowerPAD™ TSSOP - 1.2 mm max height

SMALL OUTLINE PACKAGE

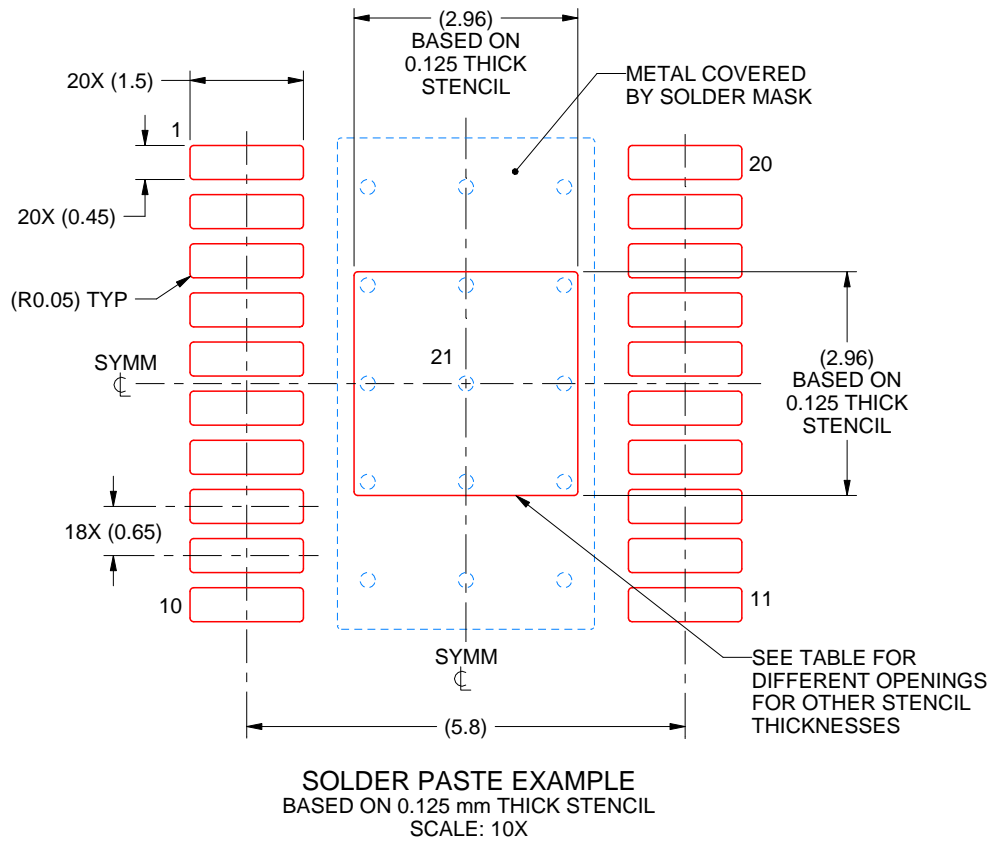

| STENCIL THICKNESS | SOLDER STENCIL OPENING |
|-------------------|------------------------|
| 0.1 | 3.31 X 3.31 |
| 0.125 | 2.96 X 2.96 (SHOWN) |
| 0.15 | 2.70 X 2.70 |
| 0.175 | 2.50 X 2.50 |

4224598/A 10/2018

NOTES: (continued)

11. Laser cutting apertures with trapezoidal walls and rounded corners may offer better paste release. IPC-7525 may have alternate design recommendations.
12. Board assembly site may have different recommendations for stencil design.

GENERIC PACKAGE VIEW

RGE 24

VQFN - 1 mm max height

PLASTIC QUAD FLATPACK - NO LEAD



Images above are just a representation of the package family, actual package may vary.
Refer to the product data sheet for package details.

4204104/H

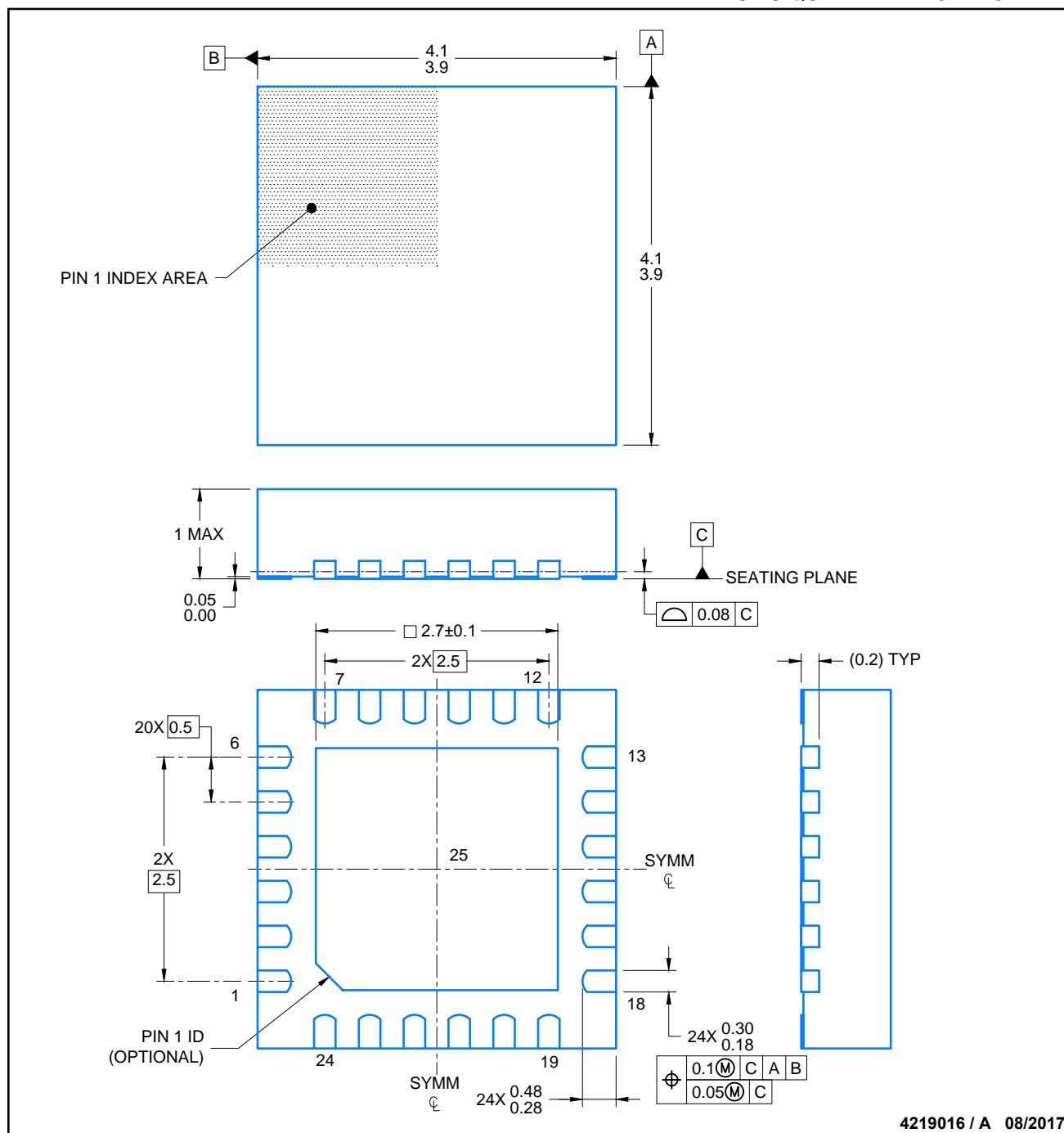

NOTES:

1. All linear dimensions are in millimeters. Any dimensions in parenthesis are for reference only. Dimensioning and tolerancing per ASME Y14.5M.
2. This drawing is subject to change without notice.
3. The package thermal pad must be soldered to the printed circuit board for thermal and mechanical performance.



LAND PATTERN EXAMPLE
SCALE: 20X



4219016 / A 08/2017

NOTES: (continued)

4. This package is designed to be soldered to a thermal pad on the board. For more information, see Texas Instruments literature number SLUA271 (www.ti.com/lit/slua271).
5. Solder mask tolerances between and around signal pads can vary based on board fabrication site.

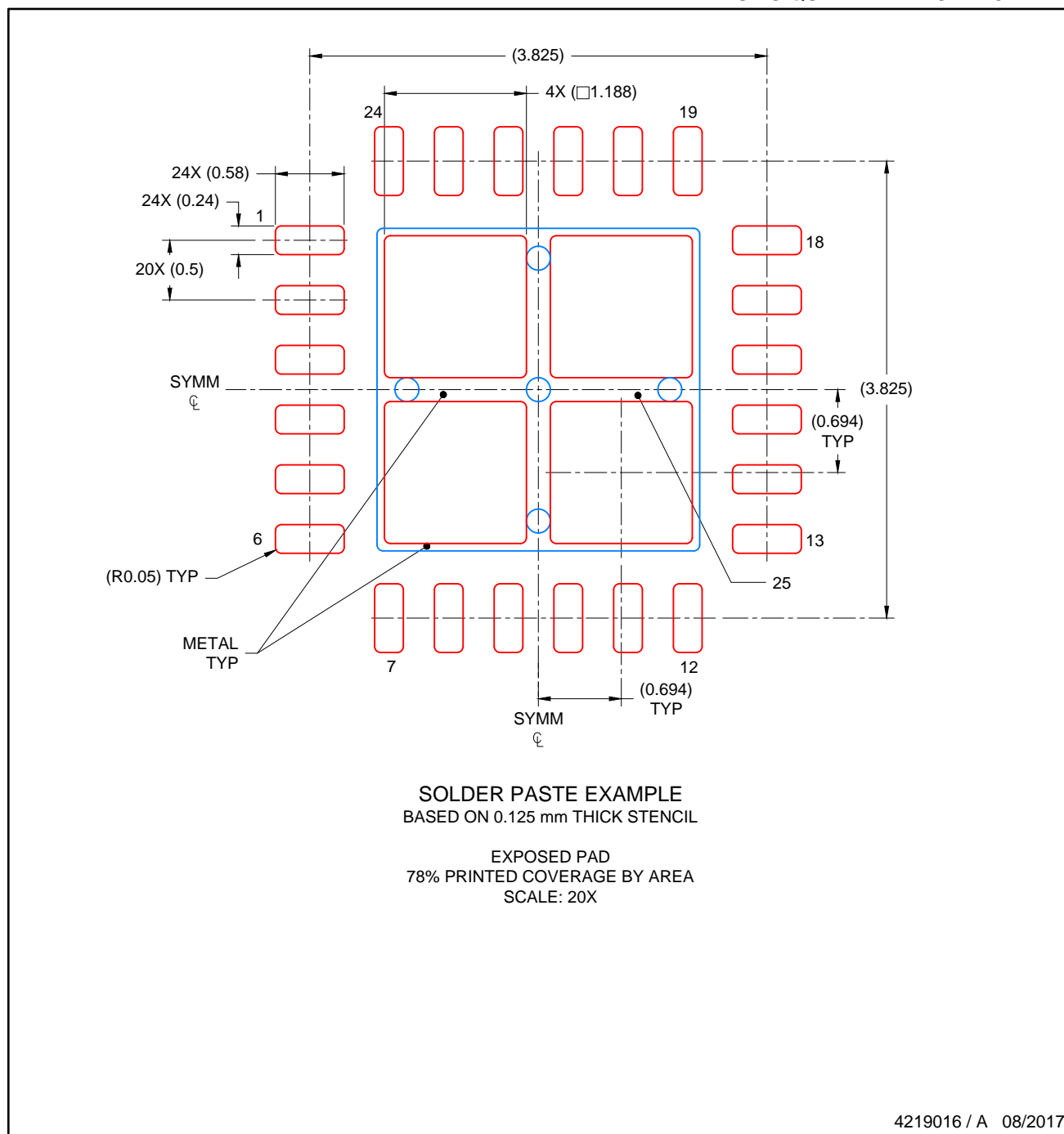

NOTES: (continued)

6. Laser cutting apertures with trapezoidal walls and rounded corners may offer better paste release. IPC-7525 may have alternate design recommendations..

重要声明和免责声明

TI“按原样”提供技术和可靠性数据（包括数据表）、设计资源（包括参考设计）、应用或其他设计建议、网络工具、安全信息和其他资源，不保证没有瑕疵且不做任何明示或暗示的担保，包括但不限于对适销性、某特定用途方面的适用性或不侵犯任何第三方知识产权的暗示担保。

这些资源可供使用 TI 产品进行设计的熟练开发人员使用。您将自行承担以下全部责任：(1) 针对您的应用选择合适的 TI 产品，(2) 设计、验证并测试您的应用，(3) 确保您的应用满足相应标准以及任何其他功能安全、信息安全、监管或其他要求。

这些资源如有变更，恕不另行通知。TI 授权您仅可将这些资源用于研发本资源所述的 TI 产品的应用。严禁对这些资源进行其他复制或展示。您无权使用任何其他 TI 知识产权或任何第三方知识产权。您应全额赔偿因在这些资源的使用中对 TI 及其代表造成的任何索赔、损害、成本、损失和债务，TI 对此概不负责。

TI 提供的产品受 [TI 的销售条款](#) 或 [ti.com](#) 上其他适用条款/TI 产品随附的其他适用条款的约束。TI 提供这些资源并不会扩展或以其他方式更改 TI 针对 TI 产品发布的适用的担保或担保免责声明。

TI 反对并拒绝您可能提出的任何其他或不同的条款。

邮寄地址：Texas Instruments, Post Office Box 655303, Dallas, Texas 75265

Copyright © 2022，德州仪器 (TI) 公司

X-ON Electronics

Largest Supplier of Electrical and Electronic Components

Click to view similar products for [Hot Swap Voltage Controllers](#) category:

Click to view products by [Texas Instruments](#) manufacturer:

Other Similar products are found below :

[LT4256-1CS8#TRPBF](#) [HIP1011BCBZA](#) [ISL6119HIBZA](#) [ISL6141IBZA](#) [ISL6151CBZA-T](#) [ISL61851ACBZ](#) [ISL61851BCBZ](#)
[ISL61851BIBZ-T](#) [ISL61851CCBZ](#) [ISL61851DCBZ](#) [ISL61851GCBZ](#) [ISL61851HCBZ](#) [ISL61851ICBZ](#) [ISL61851KCBZ](#) [TPS25961DRVR](#)
[TPS26612DDFR](#) [LM74700MDDFREP](#) [TPS23880RTQR](#) [MP5991GLU-Z](#) [MP5048GU-Z](#) [TPS259822LNRGER](#) [TPS259461ARPWR](#)
[TPS16530RGER](#) [LT4256-3IGN#TRPBF](#) [LT1641IS8#TRPBF](#) [LTC4218IGN#TRPBF](#) [LTC4210-1CS6#TRPBF](#) [LTC4211IMS8#TRPBF](#)
[RT1720GF](#) [TPS259827ONRGER](#) [TPS259823ONRGER](#) [LM74502QDDFRQ1](#) [LM5068MMX-2/NOPB](#) [LM74502HQDDFRQ1](#)
[TPS25210LRPWR](#) [TPS26601RHFR](#) [TPS26611DDFR](#) [TPS259472ARPWR](#) [LM74500QDDFRQ1](#) [TPS26610DDFR](#) [TPS259460ARPWR](#)
[LM5066IPMHX/NOPB](#) [TPS259824LNRGER](#) [TPS259823LNRGER](#) [NU6-II 60kA/385V 4P](#) [NU6-G 40kA/275V 4P](#) [NU6-II 40kA/385V 2P](#)
[TPS26635RGER](#) [AL6-NFNFBW-9](#) [AL-ECF504-AA24](#)