

# TPS3703-Q1

## 具有延时时间和手动复位功能的过压和欠压复位 IC

### 1 特性

- 符合面向汽车应用的 AEC-Q100 标准：
  - 温度等级 1：-40°C 至 +125°C， $T_A$
  - 器件 HBM ESD 分类等级 2
  - 器件 CDM ESD 分类等级 C7B
- 提供功能安全
  - 可帮助进行功能安全系统设计的文档
- 输入电压范围：1.7V 至 5.5V
- 欠压锁定 (UVLO)：1.7V
- 低静态电流：7 $\mu$ A (最大值)
- 高阈值精度：
  - $\pm 0.25\%$  (典型值)
  - $\pm 0.7\%$  (-40°C 至 +125°C)
- 固定窗口阈值电平
  - 50mV 阶跃 (500mV 至 1.3V)
  - 1.5V、1.8V、2.5V、2.8V、2.9V、3.3V、5V
  - 仅使用 UV 阈值
  - 窗口公差范围为  $\pm 3\%$  至  $\pm 7\%$
- 用户可调的电压阈值电平
- 内部毛刺抑制和迟滞
- 固定延时时间选项：50 $\mu$ s、1ms、5ms、10ms、20ms、100ms、200ms
- 使用单个外部电容器的可编程延时时间选项
- 漏极开路低电平有效 UV 和 OV 监控器
- RESET 电压锁存输出模式

### 2 应用

- 高级驾驶辅助系统 (ADAS)
- ADAS 域控制器
- 汽车信息娱乐系统和仪表盘
- 数字驾驶舱
- 混合动力汽车/电动汽车

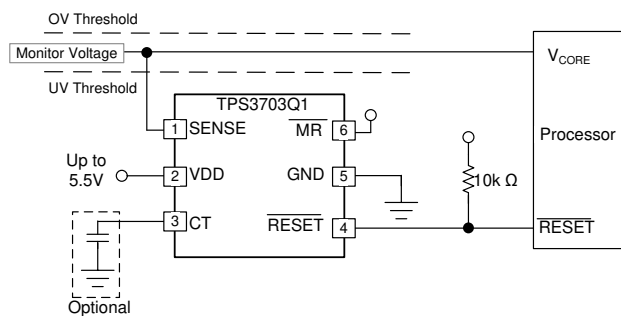

集成式过压和欠压检测

### 3 说明

TPS3703-Q1 器件是一款集成式过压 (OV) 和欠压 (UV) 监控器或复位 IC，采用业界最小的 6 引脚 DSE 封装。这款高精度的电压监控器非常适合采用低电压电源轨的系统，并具有非常小的电源容差裕度。低阈值迟滞可防止在受监控的电压处于正常工作范围内时发出虚假复位信号。并且内置有毛刺抑制功能和噪声滤波器，进一步消除了错误信号所导致的错误复位。

TPS3703-Q1 不需要使用任何外部电阻器来设置过压和欠压复位阈值，因此进一步优化了整体精度、成本、解决方案大小并提高了安全系统的可靠性。电容器时间 (CT) 引脚用于在每个器件的两个可用复位延时时间之间进行选择，还可以连接一个电容器以调整复位延时时间。单独的 SENSE 输入引脚和 VDD 引脚可实现高可靠性系统所需的冗余。

此器件的低典型静态电流规格为 4.5 $\mu$ A (典型值)。TPS3703-Q1 符合 AEC-Q100 1 级标准，适用于汽车应用。

#### 器件信息(1)

器件型号	封装	封装尺寸 (标称值)
TPS3703-Q1	WSON (6)	1.50mm x 1.50mm

- (1) 如需了解所有可用封装，请参阅数据表末尾的可订购产品附录。

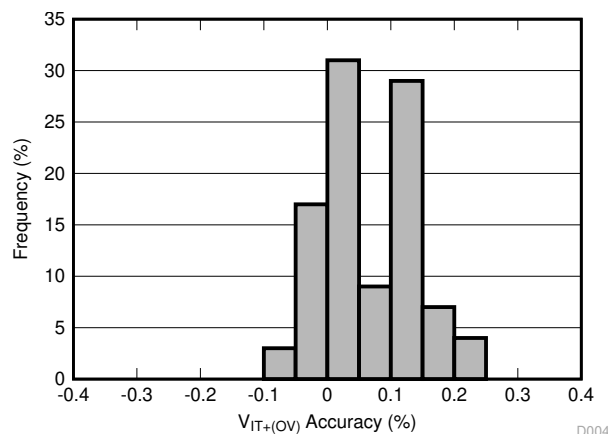

典型过压精度分布

D004



## Table of Contents

<b>1 特性</b> .....	1	8.4 Device Functional Modes.....	16
<b>2 应用</b> .....	1	<b>9 Application and Implementation</b> .....	17
<b>3 说明</b> .....	1	9.1 Application Information.....	17
<b>4 Revision History</b> .....	2	9.2 Typical Applications.....	22
<b>5 Device Comparison</b> .....	3	<b>10 Power Supply Recommendations</b> .....	26
<b>6 Pin Configuration and Functions</b> .....	4	10.1 Power Supply Guidelines.....	26
<b>7 Specifications</b> .....	5	<b>11 Layout</b> .....	26
7.1 Absolute Maximum Ratings.....	5	11.1 Layout Guidelines.....	26
7.2 ESD Ratings.....	5	11.2 Layout Example.....	26
7.3 Recommended Operating Conditions.....	5	<b>12 Device and Documentation Support</b> .....	27
7.4 Thermal Information.....	6	12.1 Device Support.....	27
7.5 Electrical Characteristics.....	6	12.2 Documentation Support.....	29
7.6 Timing Requirements.....	7	12.3 接收文档更新通知.....	29
7.7 Timing Diagrams.....	8	12.4 支持资源.....	29
7.8 Typical Characteristics.....	10	12.5 Trademarks.....	29
<b>8 Detailed Description</b> .....	14	12.6 静电放电警告.....	29
8.1 Overview.....	14	12.7 术语表.....	29
8.2 Functional Block Diagram.....	14	<b>13 Mechanical, Packaging, and Orderable Information</b> .....	29
8.3 Feature Description.....	14		

## 4 Revision History

注：以前版本的页码可能与当前版本的页码不同

<b>Changes from Revision C (February 2020) to Revision D (March 2021)</b>	<b>Page</b>
• 更新了整个文档中的表格、图和交叉参考的编号格式.....	1
• 包含了“功能安全”要点.....	1
• Replaced <i>Device Comparison Table</i> with device nomenclature legend.....	3
<b>Changes from Revision B (September 2019) to Revision C (February 2020)</b>	<b>Page</b>
• Changed reset time delay nomenclature ( $t_D$ ): J to M by A to H.....	7
<b>Changes from Revision A (May 2019) to Revision B (September 2019)</b>	<b>Page</b>
• 仅删除了整篇文档中的 OV.....	1
• 将整个文档中的阈值公差更改为窗口公差.....	1
• Added new voltage variants for window and UV only.....	3
• Added pinout description for package.....	4
• Changed functional block diagram for clarity between variants. ....	14
• Added UV only normal operation condition. ....	16
• Changed equation to correctly reflect resistor divider. ....	20
• Changed to $R_1$ from $R_{SENSE}$ .....	20
<b>Changes from Revision * (November 2018) to Revision A (May 2019)</b>	<b>Page</b>
• 将“预告信息”更改为“量产数据”发布.....	1

## 5 Device Comparison

图 5-1 shows the device nomenclature of the TPS3703-Q1. For all possible voltages, window tolerance, time delays, and UV threshold options, see 表 12-1. Contact TI sales representatives or on TI's [E2E forum](#) for details and availability of other options; minimum order quantities apply.

**TPS 3703 X X XXX XXX RQ1**



图 5-1. Device Nomenclature Legend

## 6 Pin Configuration and Functions

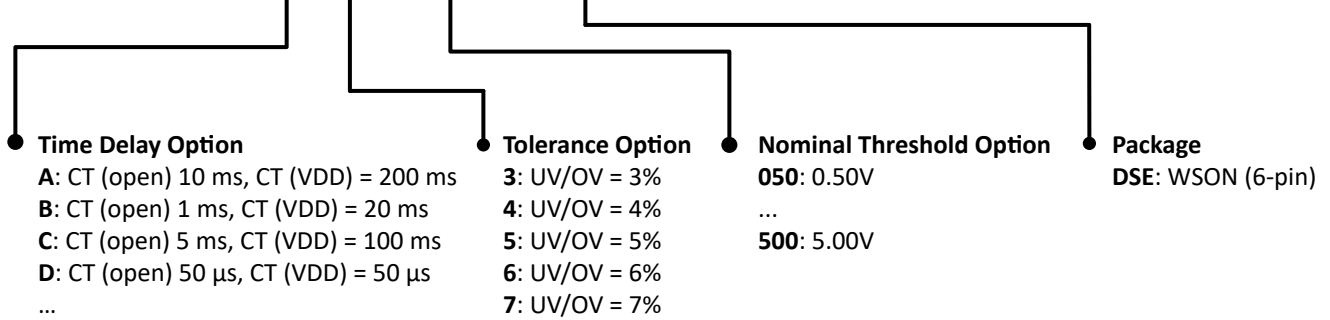

图 6-1. DSE Package, 6-Pin WSON, Top View

表 6-1. Pin Functions

PIN		I/O	DESCRIPTION
NO.	NAME		
1	SENSE	I	Input for the monitored supply voltage rail. When the SENSE voltage goes above the overvoltage threshold or below the undervoltage threshold, the RESET pin is driven low. Connect to VDD pin if monitoring VDD supply voltage.
2	VDD	I	Supply voltage input pin. Good analog design practice is to place a 0.1- $\mu$ F ceramic capacitor close to this pin.
3	CT	I	Capacitor time delay pin. The CT pin offers two fixed time delays by connecting CT pin to VDD or leaving it floating. Delay time can be programmed by connecting an external capacitor reference to ground.
4	RESET	O	Active-low, open-drain output. This pin goes low when the SENSE voltage rises above the internally overvoltage threshold ( $V_{IT+}$ ) or below the undervoltage threshold ( $V_{IT-}$ ). See the timing diagram in <a href="#">图 8-2</a> for more details. Connect this pin to a pull-up resistor terminated to the desired pull-up voltage.
5	GND	—	Ground
6	MR	I	Manual reset (MR), pull this pin to a logic low ( $V_{MR_L}$ ) to assert a reset signal. After the MR pin is deasserted the output goes high after the reset delay time ( $t_D$ ) expires. MR can be left floating when not in use.

## 7 Specifications

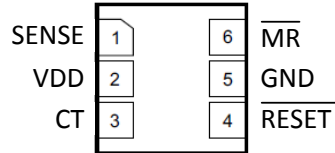
### 7.1 Absolute Maximum Ratings

over operating free-air temperature range (unless otherwise noted)<sup>(1)</sup>

		MIN	MAX	UNIT
Voltage	V <sub>DD</sub>	- 0.3	6	V
	V <sub>RESET</sub>	- 0.3	6	
	V <sub>CT</sub>	- 0.3	6	
	V <sub>SENSE</sub>	- 0.3	6	
	V <sub>MR</sub>	- 0.3	6	
Current	I <sub>RESET</sub>		±40	mA
Temperature <sup>(2)</sup>	Continuous total power dissipation	See the Thermal Information		
	Operating junction temperature, T <sub>J</sub>	- 40	150	°C
	Operating free-air temperature, T <sub>A</sub>	- 40	150	
	Storage temperature, T <sub>stg</sub>	- 65	150	

- (1) Stresses beyond values listed under Absolute Maximum Ratings may cause permanent damage to the device. These are stress ratings only, which do not imply functional operation of the device at these or any other conditions beyond those indicated under Recommended Operating Conditions. Exposure to absolute-maximum-rated conditions for extended periods may affect device reliability.
- (2) As a result of the low dissipated power in this device, it is assumed that T<sub>J</sub> = T<sub>A</sub>.

### 7.2 ESD Ratings

			VALUE	UNIT	
V <sub>(ESD)</sub>	Electrostatic discharge	Human-body model (HBM), per ANSI/ESDA/JEDEC JS-001 <sup>(1)</sup>	±2000	V	
		Charged-device model (CDM), per AEC Q100-011	All pins		±500
			Corner pins		±750

- (1) AEC Q100-002 indicates that HBM stressing shall be in accordance with the ANSI/ESDA/JEDEC JS-001 specification

### 7.3 Recommended Operating Conditions

		MIN	NOM	MAX	UNIT
V <sub>DD</sub>	Supply pin voltage	1.7		5.5	V
V <sub>SENSE</sub>	Input pin voltage	0		5.5	V
V <sub>CT</sub>	CT pin voltage <sup>(1) (3)</sup>			V <sub>DD</sub>	V
V <sub>RESET</sub>	Output pin voltage	0		5.5	V
V <sub>MR</sub>	MR pin voltage <sup>(2)</sup>	0		5.5	V
I <sub>RESET</sub>	Output pin current	0.3		10	mA
T <sub>J</sub>	Junction temperature (free-air temperature)	- 40		125	°C

- (1) CT pin connected to V<sub>DD</sub> pin requires a pullup resistor; 10 kΩ is recommended.
- (2) If the logic signal driving MR is less than V<sub>DD</sub>, then additional current flows into V<sub>DD</sub> and out of MR.
- (3) The maximum rating is V<sub>DD</sub> or 5.5 V, whichever is smaller.

## 7.4 Thermal Information

THERMAL METRIC <sup>(1)</sup>		TPS3703-Q1	
		DSE (WSON)	
		PINS	
			UNIT
$R_{\theta JA}$	Junction-to-ambient thermal resistance	184.2	°C/W
$R_{\theta JC(top)}$	Junction-to-case (top) thermal resistance	30.6	°C/W
$R_{\theta JB}$	Junction-to-board thermal resistance	86.4	°C/W
$\Psi_{JT}$	Junction-to-top characterization parameter	13.4	°C/W
$\Psi_{JB}$	Junction-to-board characterization parameter	86.1	°C/W
$R_{\theta JC(bot)}$	Junction-to-case (bottom) thermal resistance	N/A	°C/W

(1) For more information about traditional and new thermal metrics, see the [Semiconductor and IC Package Thermal Metrics application report](#).

## 7.5 Electrical Characteristics

At  $1.7\text{ V} \leq V_{DD} \leq 5.5\text{ V}$ ,  $CT = \overline{MR} = \text{Open}$ ,  $\overline{\text{RESET}}$  Voltage ( $V_{\text{RESET}}$ ) =  $10\text{ k}\Omega$  to  $V_{DD}$ ,  $\overline{\text{RESET}}$  load =  $10\text{ pF}$ , and over the operating free-air temperature range of  $-40^\circ\text{C}$  to  $125^\circ\text{C}$ , unless otherwise noted. Typical values are at  $T_J = 25^\circ\text{C}$ , typical conditions at  $V_{DD} = 3.3\text{ V}$ .

PARAMETER		TEST CONDITIONS	MIN	TYP	MAX	UNIT
$V_{DD}$	Supply voltage		1.7		5.5	V
UVLO	Under voltage lockout <sup>(3)</sup>	$V_{DD}$ falling below $1.7\text{ V}$	1.2		1.7	V
$V_{POR}$	Power on reset voltage <sup>(2)</sup>	$V_{OL(max)} = 0.25\text{ V}$ , $I_{OUT} = 15\text{ }\mu\text{A}$			1	V
$V_{IT+(OV)}$	Positive-going threshold accuracy		-0.7	$\pm 0.25$	0.7	%
$V_{IT-(UV)}$	Negative-going threshold accuracy		-0.7	$\pm 0.25$	0.7	%
$V_{HYS}$	Hysteresis voltage <sup>(1)</sup>		0.3	0.55	0.8	%
$I_{DD}$	Supply current	$V_{DD} \leq 5.5\text{ V}$		4.5	7	$\mu\text{A}$
$I_{SENSE}$	Input current, SENSE pin	$V_{SENSE} = 5\text{ V}$		1	1.5	$\mu\text{A}$
$V_{OL}$	Low level output voltage	$V_{DD} = 1.7\text{ V}$ , $I_{OUT} = 0.4\text{ mA}$			250	mV
		$V_{DD} = 2\text{ V}$ , $I_{OUT} = 3\text{ mA}$			250	mV
		$V_{DD} = 5\text{ V}$ , $I_{OUT} = 5\text{ mA}$			250	mV
$I_{LKG}$	Open drain output leakage current	$V_{DD} = V_{\text{RESET}} = 5.5\text{ V}$			300	nA
$V_{MR\_L}$	$\overline{MR}$ logic low input				0.3	V
$V_{MR\_H}$	$\overline{MR}$ logic high input		1.4			V
$V_{CT\_H}$	High level CT pin voltage		1.4			V
$R_{MR}$	Manual reset Internal pullup resistance			100		$\text{K}\Omega$
$I_{CT}$	CT pin charge current		337	375	413	nA
$V_{CT}$	CT pin comparator threshold voltage <sup>(4)</sup>		1.133	1.15	1.167	V

- (1) Hysteresis is with respect of the tripoint ( $V_{IT-(UV)}$ ,  $V_{IT+(OV)}$ ).
- (2)  $V_{POR}$  is the minimum  $V_{DD}$  voltage level for a controlled output state.
- (3)  $\overline{\text{RESET}}$  pin is driven low when  $V_{DD}$  falls below UVLO.
- (4)  $V_{CT}$  voltage refers to the comparator threshold voltage that measures the voltage level of the external capacitor at CT pin.

## 7.6 Timing Requirements

At  $1.7\text{ V} \leq V_{DD} \leq 5.5\text{ V}$ ,  $CT = \overline{MR} = \text{Open}$ ,  $\overline{RESET}$  Voltage ( $V_{RESET}$ ) =  $10\text{ k}\Omega$  to  $V_{DD}$ ,  $\overline{RESET}$  load =  $10\text{ pF}$ , and over the operating free-air temperature range of  $-40^\circ\text{C}$  to  $125^\circ\text{C}$ , unless otherwise noted. Typical values are at  $T_J = 25^\circ\text{C}$ , typical conditions at  $V_{DD} = 3.3\text{ V}$ .

			MIN	NOM	MAX	UNIT
$t_D$	Reset time delay, TPS3703A, TPS3703E	$CT = \text{Open}$	7	10	13	ms
	Reset time delay, TPS3703A, TPS3703E	$CT = 10\text{ k}\Omega$ to $V_{DD}$	140	200	260	
	Reset time delay, TPS3703B, TPS3703F	$CT = \text{Open}$	0.7	1	1.3	
	Reset time delay, TPS3703B, TPS3703F	$CT = 10\text{ k}\Omega$ to $V_{DD}$	14	20	26	
	Reset time delay, TPS3703C, TPS3703G	$CT = \text{Open}$	3.5	5	6.5	
	Reset time delay, TPS3703C, TPS3703G	$CT = 10\text{ k}\Omega$ to $V_{DD}$	70	100	130	
	Reset time delay, TPS3703D, TPS3703H	$CT = 10\text{ k}\Omega$ to $V_{DD}$ $CT = \text{Open}$		50		$\mu\text{s}$
$t_{PD}$	Propagation detect delay <sup>(1) (2)</sup>			15	30	$\mu\text{s}$
$t_R$	Output rise time <sup>(1) (3)</sup>			2.2		$\mu\text{s}$
$t_F$	Output fall time <sup>(1) (3)</sup>			0.2		$\mu\text{s}$
$t_{SD}$	Startup delay <sup>(4)</sup>			300		$\mu\text{s}$
$t_{GI} (V_{IT-})$	Glitch Immunity undervoltage $V_{IT-(UV)}$ , 5% Overdrive <sup>(1)</sup>			3.5		$\mu\text{s}$
$t_{GI} (V_{IT+})$	Glitch Immunity overvoltage $V_{IT+(OV)}$ , 5% Overdrive <sup>(1)</sup>			3.5		$\mu\text{s}$
$t_{GI} (\overline{MR})$	Glitch Immunity $\overline{MR}$ pin				25	ns
$t_{PD} (\overline{MR})$	Propagation delay from $\overline{MR}$ low to assert $\overline{RESET}$			500		ns
$t_{MR\_W}$	$\overline{MR}$ pin pulse width duration to assert $\overline{RESET}$		1			$\mu\text{s}$
$t_D (\overline{MR})$	$\overline{MR}$ reset time delay			$t_D$		ms

- (1) 5% Overdrive from threshold. Overdrive % =  $[V_{SENSE} - V_{IT}] / V_{IT}$ ; Where  $V_{IT}$  stands for  $V_{IT-(UV)}$  or  $V_{IT+(OV)}$
- (2)  $t_{PD}$  measured from threshold trip point ( $V_{IT-(UV)}$  or  $V_{IT+(OV)}$ ) to  $\overline{RESET}$   $V_{OL}$  voltage
- (3) Output transitions from  $V_{OL}$  to 90% for rise times and 90% to  $V_{OL}$  for fall times.
- (4) During the power-on sequence,  $V_{DD}$  must be at or above  $V_{DD(MIN)}$  for at least  $t_{SD} + t_D$  before the output is in the correct state.

## 7.7 Timing Diagrams



图 7-1. Voltage Threshold and Hysteresis Accuracy



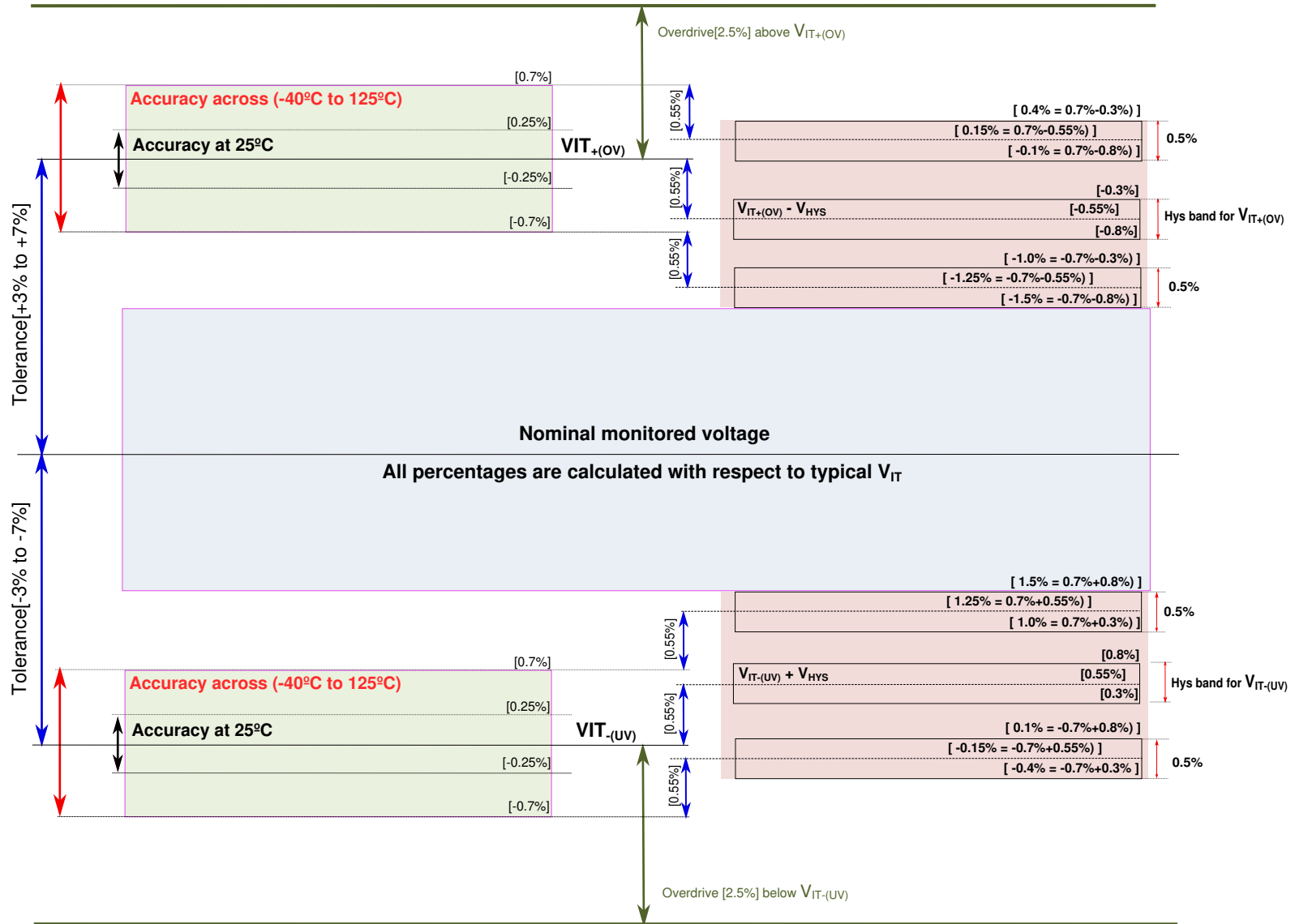
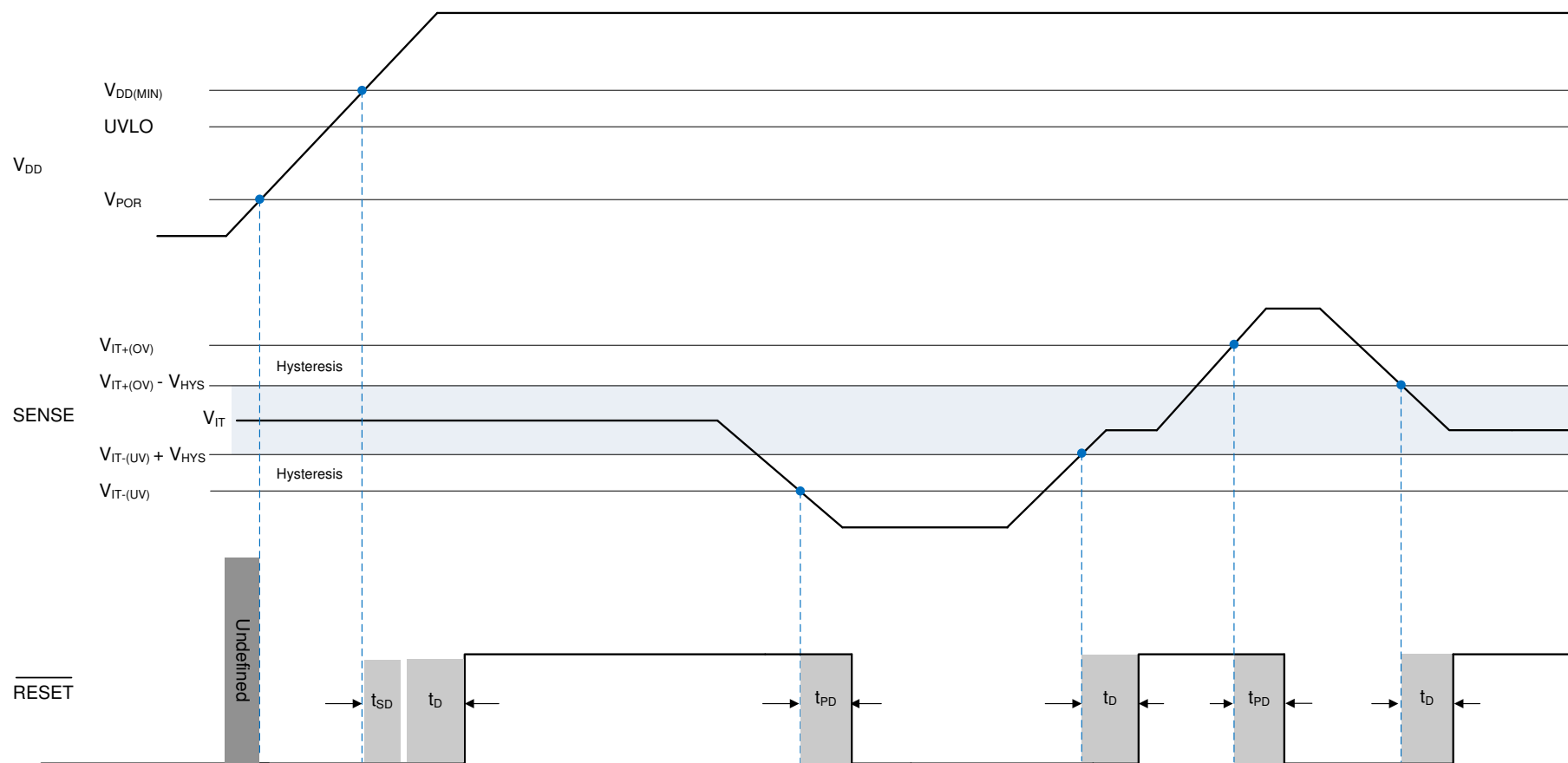

- A.  $V_{DD} = 2\text{ V}$ ,  $R_{PU} = 10\text{ k}\Omega$  to  $V_{DD}$ .
- B. Variant D (time delay bypass) has a  $\sim 40\text{ }\mu\text{s}$  pulse at **RESET** pin during power up window, this is present only when the power cycle off time is longer than 10 seconds, this behavior will not occur if the **SENSE** pin is within window of operation during  $V_{DD}$  power up.

**图 7-2. SENSE Timing Diagram**

## 7.8 Typical Characteristics

at  $T_J = 25^\circ\text{C}$ ,  $V_{DD} = 3.3\text{ V}$ , and  $R_{PU} = 10\text{ k}\Omega$  (unless otherwise noted)

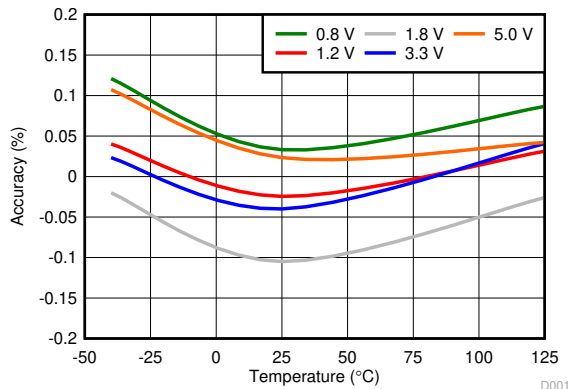

Tested across multiple voltage options

图 7-3. Undervoltage Accuracy vs Temperature

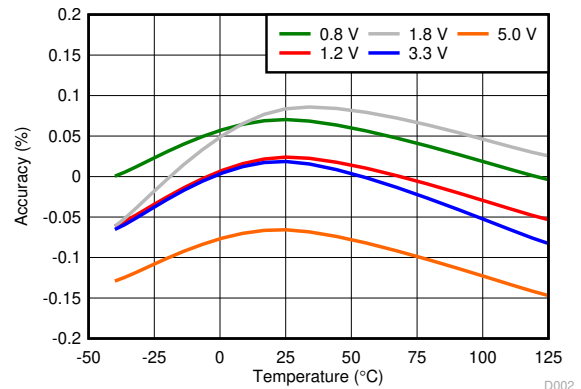

Tested across multiple voltage options

图 7-4. Overvoltage Accuracy vs Temperature

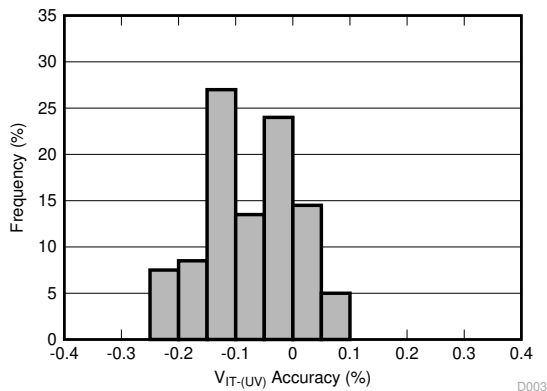

Sample Size of 100 TPS3703A7125 units

图 7-5. Undervoltage Accuracy Distribution

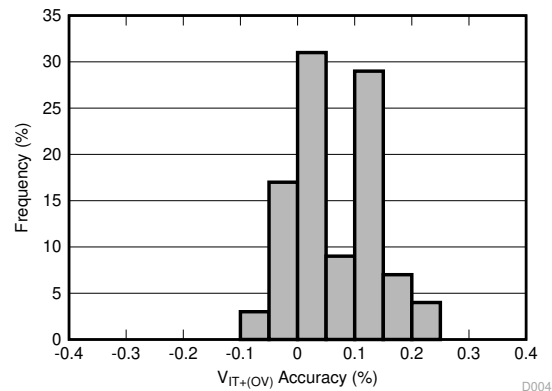

Sample Size of 100 TPS3703A7125 units

图 7-6. Overvoltage Accuracy Distribution

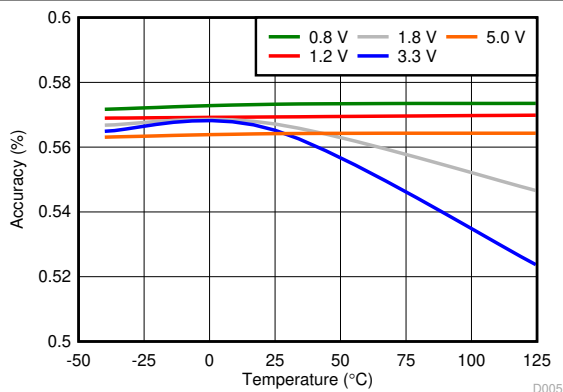

Tested across multiple voltage options

图 7-7. Undervoltage Hysteresis Voltage Accuracy vs Temperature

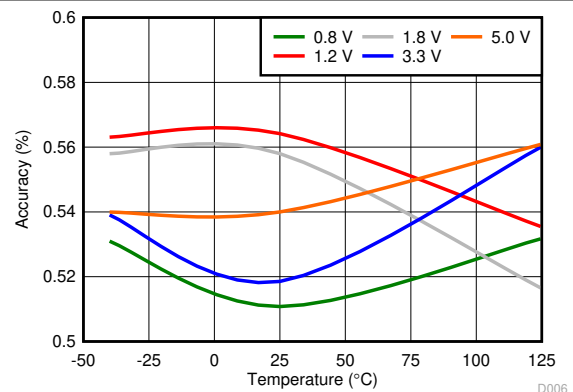

Tested across multiple voltage options

图 7-8. Overvoltage Hysteresis Voltage Accuracy vs Temperature

## 7.8 Typical Characteristics (continued)

at  $T_J = 25^\circ\text{C}$ ,  $V_{DD} = 3.3\text{ V}$ , and  $R_{PU} = 10\text{ k}\Omega$  (unless otherwise noted)



图 7-9. Supply Current vs Temperature



图 7-10. Supply Current vs Temperature

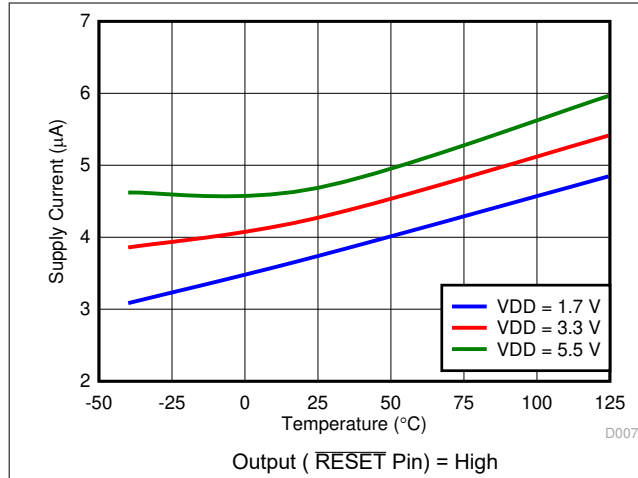

图 7-11. SENSE Glitch Immunity (VIT-) vs Overdrive

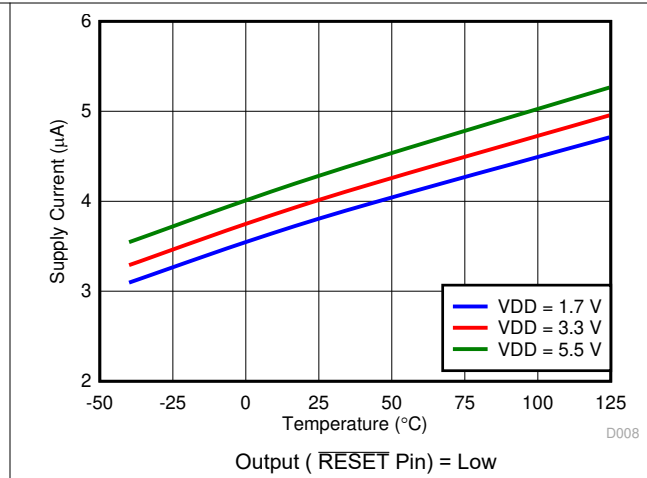

图 7-12. SENSE Glitch Immunity (VIT+) vs Overdrive

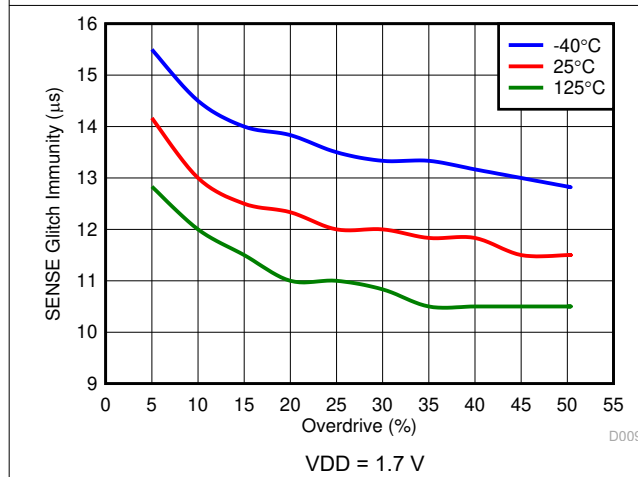

图 7-13. SENSE Glitch Immunity (VIT-) vs Overdrive

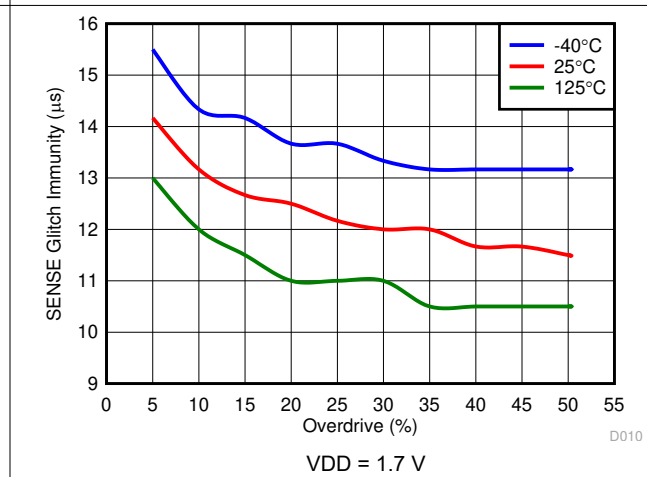

图 7-14. SENSE Glitch Immunity (VIT+) vs Overdrive

## 7.8 Typical Characteristics (continued)

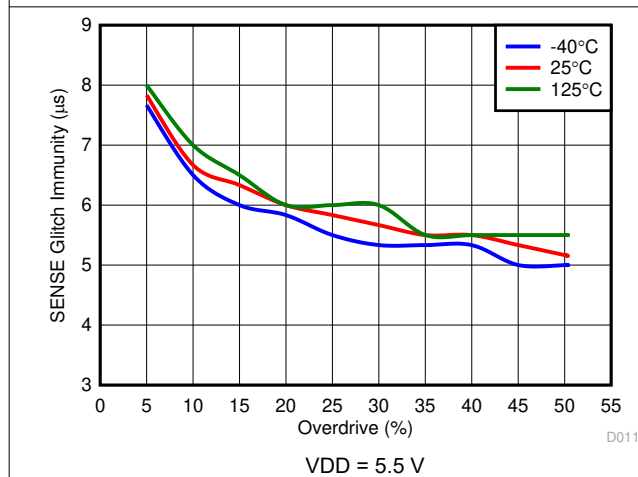
at  $T_J = 25^\circ\text{C}$ ,  $V_{DD} = 3.3\text{ V}$ , and  $R_{PU} = 10\text{ k}\Omega$  (unless otherwise noted)

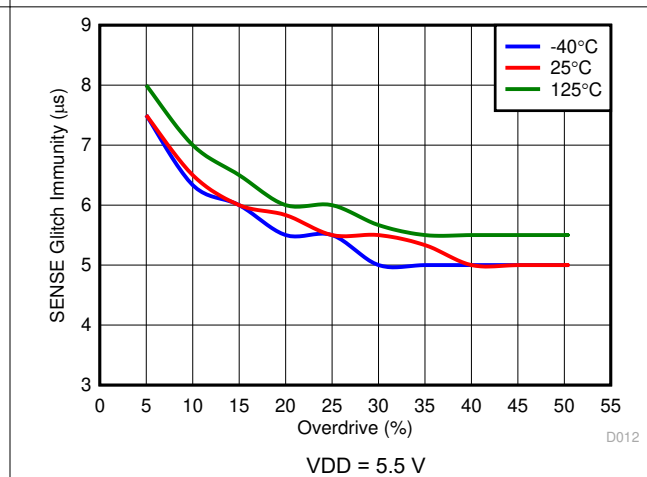

图 7-15. Low-Level Output Voltage vs RESET current



图 7-16. Low-Level Output Voltage vs RESET current

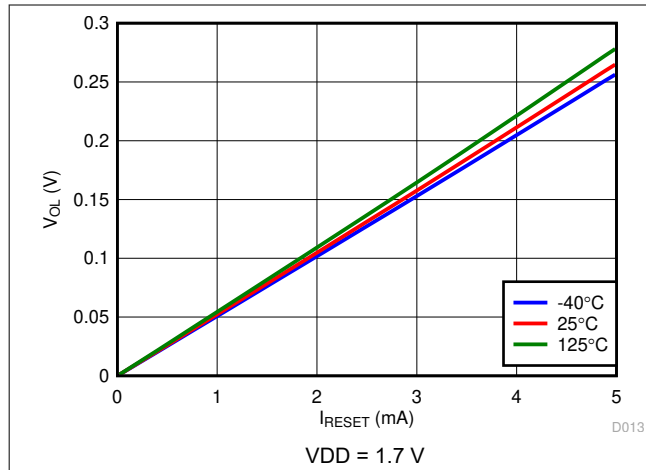

图 7-17. SET Threshold vs Temperature

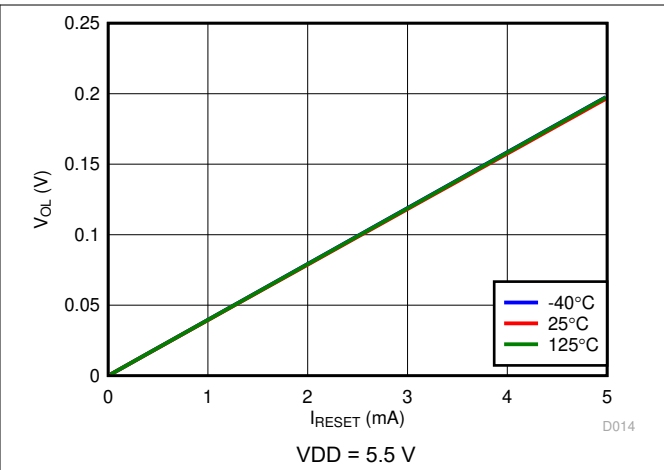

图 7-18. SET Threshold vs Temperature

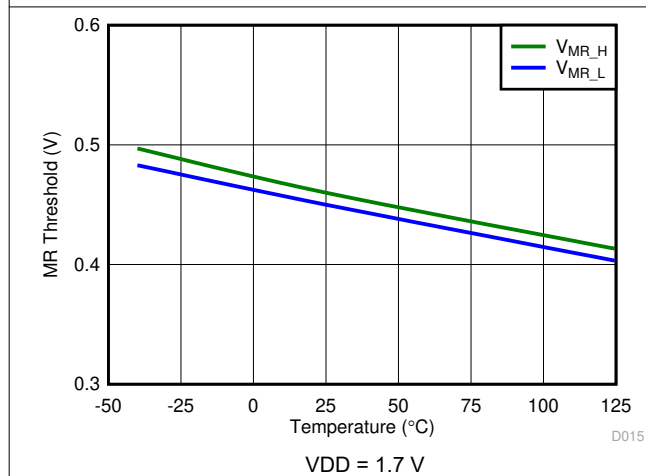

图 7-19. CT Current vs CT value

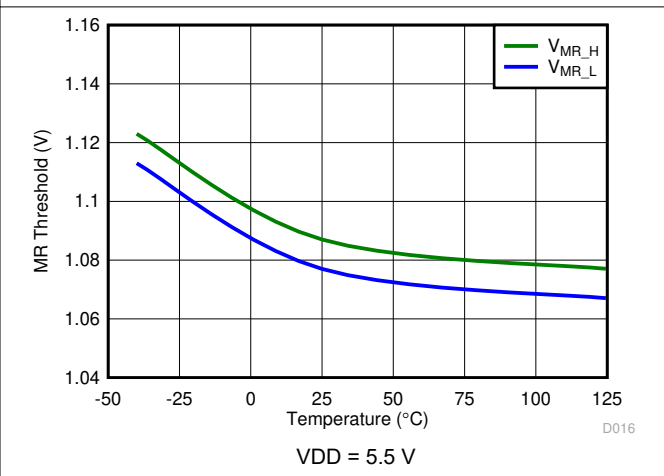

图 7-20. RESET Timeout vs CT Capacitor

## 7.8 Typical Characteristics (continued)

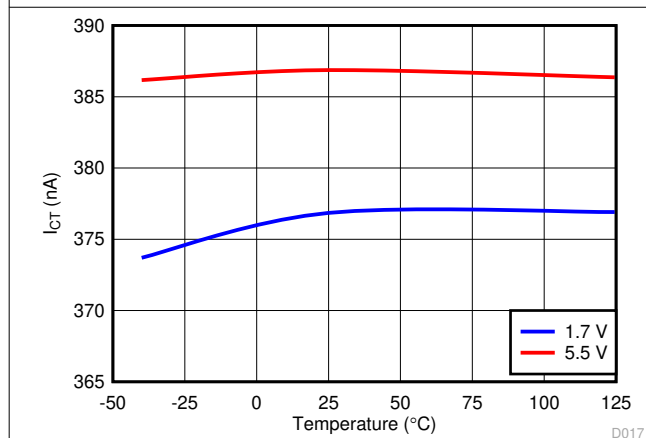
at  $T_J = 25^\circ\text{C}$ ,  $V_{DD} = 3.3\text{ V}$ , and  $R_{PU} = 10\text{ k}\Omega$  (unless otherwise noted)

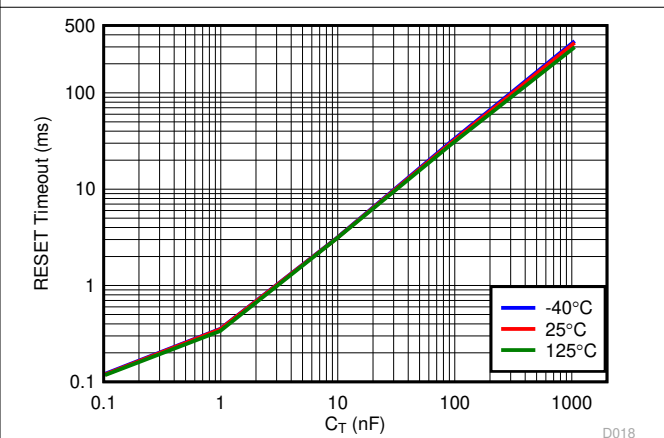

图 7-21. Timeout vs CT Capacitor (0.1 to 10 nF)



图 7-22. Detect Propagation Delay vs Temperature

## 8 Detailed Description

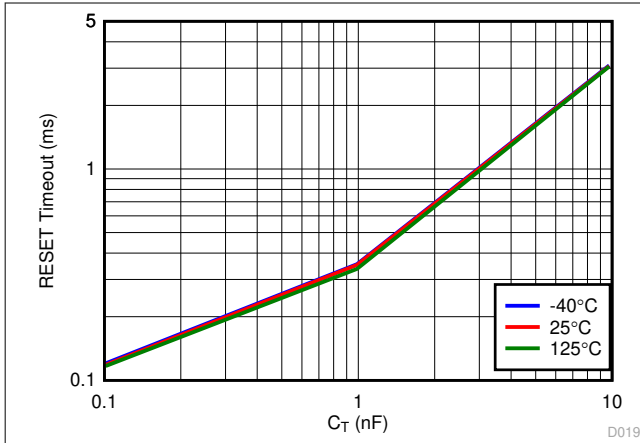
### 8.1 Overview

The TPS3703-Q1 family of devices combines two voltage comparators and a precision voltage reference for overvoltage and undervoltage detection. The TPS3703-Q1 features a highly accurate window threshold voltages ( $\pm 0.7\%$  over temperature) and a variety voltage threshold variants.

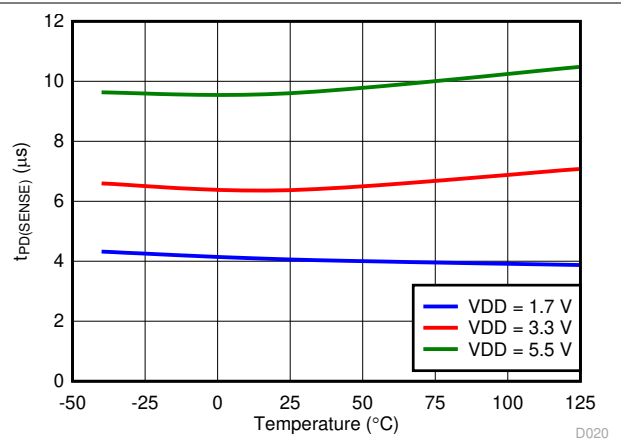
The TPS3703-Q1 includes the resistors used to set the overvoltage and undervoltage thresholds internal to the device. These internal resistors allow for lower component counts and greatly simplifies the design because no additional margins are needed to account for the accuracy of external resistors.

TPS3703-Q1 version A, B and C has three time delay settings, two fixed by connecting CT pin to VDD through a resistor and leaving CT floating and a programmable time delay setting that only requires a single capacitor connected from CT pin to ground.

Manual Reset ( $\overline{\text{MR}}$ ) allows for sequencing or hard reset by driving the  $\overline{\text{MR}}$  pin below  $V_{\text{MR}_L}$ .

The TPS3703-Q1 is designed to assert active low output signals when the monitored voltage is outside the safe window. The relationship between the monitored voltage and the states of the outputs is shown in [表 8-1](#).

### 8.2 Functional Block Diagram

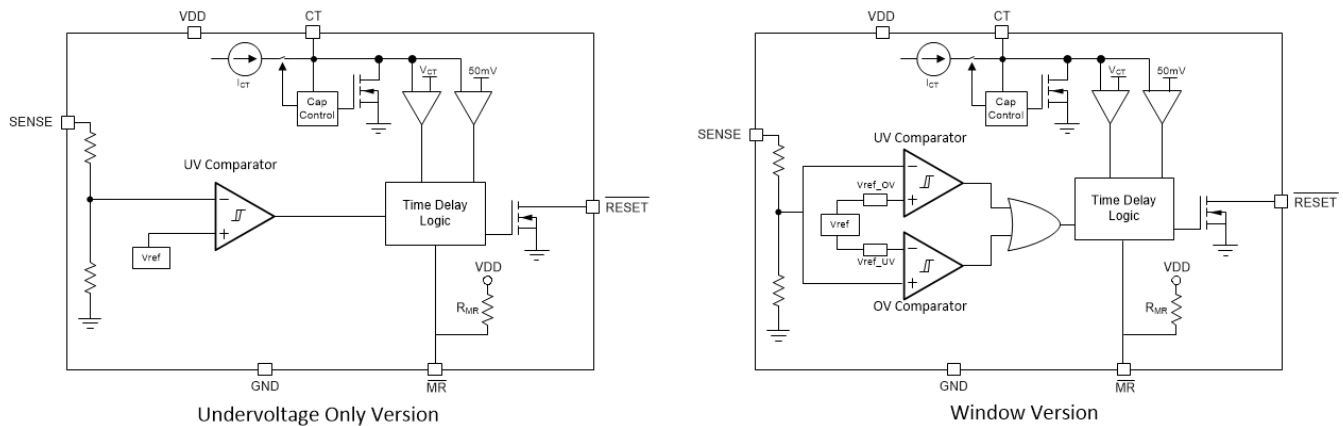

\*For all possible voltages, window tolerance, time delays, and UV threshold options, see [表 12-1](#).

### 8.3 Feature Description

#### 8.3.1 VDD

The TPS3703-Q1 is designed to operate from an input voltage supply range between 1.7 V to 5.5 V. An input supply capacitor is not required for this device; however, if the input supply is noisy good analog practice is to place a 1- $\mu\text{F}$  capacitor between the VDD pin and the GND pin.

$V_{\text{DD}}$  needs to be at or above  $V_{\text{DD(MIN)}}$  for at least the start-up delay ( $t_{\text{SD}} + t_{\text{D}}$ ) for the device to be fully functional.

#### 8.3.2 SENSE

The TPS3703-Q1 combines two comparators with a precision reference voltage and a trimmed resistor divider. This configuration optimizes device accuracy because all resistor tolerances are accounted for in the accuracy and performance specifications. Both comparators also include built-in hysteresis that provides noise immunity and ensures stable operation.

Although not required in most cases, for noisy applications good analog design practice is to place a 1-nF to 10-nF bypass capacitor at the SENSE input in order to reduce sensitivity to transient voltages on the monitored signal.

When monitoring VDD supply voltage, the SENSE pin can be connected directly to VDD. The output ( $\overline{\text{RESET}}$ ) is high impedance when voltage at the SENSE pin is between upper and lower boundary of threshold.

### 8.3.3 RESET

In a typical TPS3703-Q1 application, the  $\overline{\text{RESET}}$  output is connected to a reset or enable input of a processor [such as a digital signal processor (DSP), application-specific integrated circuit (ASIC), or other processor type] or the enable input of a voltage regulator [such as a DC-DC converter or low-dropout regulator (LDO)].

The TPS3703-Q1 has an open drain active low output that requires a pull-up resistor to hold these lines high to the required voltage logic. Connect the pull-up resistor to the proper voltage rail to enable the output to be connected to other devices at the correct interface voltage levels. To ensure proper voltage levels, give some consideration when choosing the pull-up resistor values. The pull-up resistor value is determined by  $V_{OL}$ , output capacitive loading, and output leakage current. These values are specified in [7](#). The open drain output can be connected as a wired-OR logic with other open drain signals such as another TPS3703-Q1  $\overline{\text{RESET}}$  pin.

表 8-1 describes the scenarios when the output ( $\overline{\text{RESET}}$ ) is either asserted low or high impedance.



图 8-1. RESET output

### 8.3.4 Capacitor Time (CT)

The CT pin provides the user the functionality of both high-precision, factory-programmed, reset delay timing options and user-programmable, reset delay timing. The CT pin can be pulled up to  $V_{DD}$  through a resistor, have an external capacitor to ground, or can be left unconnected. The configuration of the CT pin is re-evaluated by the device every time the voltage on the SENSE line enters the valid window ( $V_{IT-(UV)} < V_{SENSE} < V_{IT+(OV)}$ ). The pin evaluation is controlled by an internal state machine that determines which option is connected to the CT pin. The sequence of events takes  $450 \mu\text{s}$  to determine if the CT pin is left unconnected, pulled up through a resistor, or connected to a capacitor. If the CT pin is being pulled up to  $V_{DD}$ , then a pull-up resistor is required,  $10 \text{ k}\Omega$  is recommended.

### 8.3.5 Manual Reset ( $\overline{\text{MR}}$ )

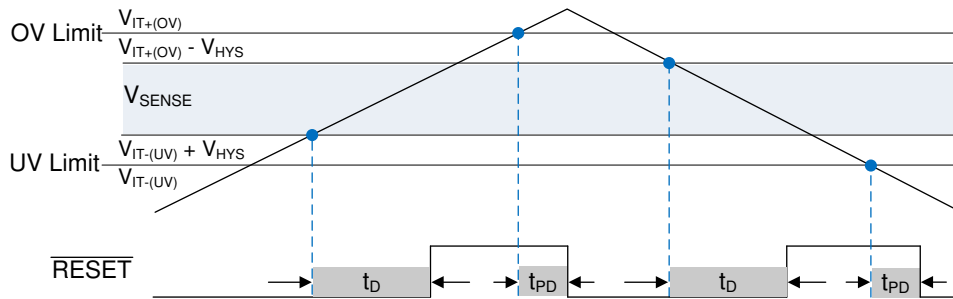
The manual reset ( $\overline{\text{MR}}$ ) input allows a processor or other logic circuits to initiate a reset. A logic low on  $\overline{\text{MR}}$  causes  $\overline{\text{RESET}}$  to assert. After  $\overline{\text{MR}}$  returns to a logic high and the SENSE pin voltage is within a valid window ( $V_{IT-(UV)} < V_{SENSE} < V_{IT+(OV)}$ ),  $\overline{\text{RESET}}$  is deasserted after the reset delay time ( $t_D$ ). If  $\overline{\text{MR}}$  is not controlled externally, then  $\overline{\text{MR}}$  can either be connected to  $V_{DD}$  or left floating because the  $\overline{\text{MR}}$  pin is internally pulled up to  $V_{DD}$ . Figure [8-2](#) shows the relation between  $\overline{\text{MR}}$  and  $\overline{\text{RESET}}$ .

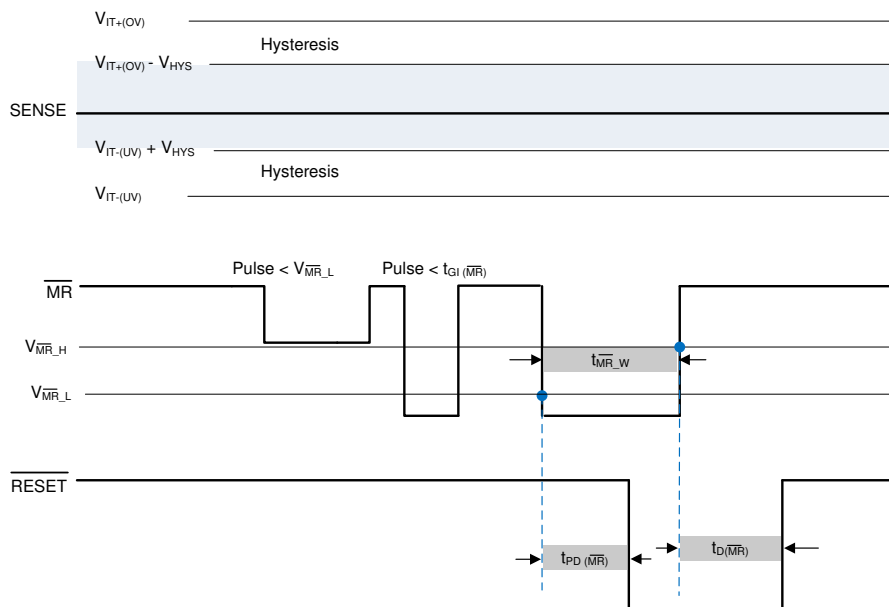

- $\overline{RESET}$  pulls up to  $V_{DD}$  with 10 k $\Omega$ .
- To initiate and continue time reset counter both conditions must be met  $\overline{MR}$  pin above  $V_{MR\_H}$  or floating and  $V_{SENSE}$  between  $V_{IT-(UV)} + V_{HYS}$  and  $V_{IT+(OV)} - V_{HYS}$
- $\overline{MR}$  is ignored during output  $\overline{RESET}$  low event

**图 8-2. Manual Reset Timing Diagram**

## 8.4 Device Functional Modes

**表 8-1. Functional Mode Truth Table**

DESCRIPTION	CONDITION	$\overline{MR}$ PIN	VDD PIN	OUTPUT ( RESET PIN)
Normal Operation	$V_{IT-(UV)} < SENSE < V_{IT+(OV)}$	Open or above $V_{MR\_H}$	$V_{DD} > V_{DD(MIN)}$	High
Normal Operation (UV Only)	$SENSE > V_{IT-(UV)}$	Open or above $V_{MR\_H}$	$V_{DD} > V_{DD(MIN)}$	High
Over Voltage detection	$SENSE > V_{IT+(OV)}$	Open or above $V_{MR\_H}$	$V_{DD} > V_{DD(MIN)}$	Low
Under Voltage detection	$SENSE < V_{IT-(UV)}$	Open or above $V_{MR\_H}$	$V_{DD} > V_{DD(MIN)}$	Low
Manual reset	$V_{IT-(UV)} < SENSE < V_{IT+(OV)}$	Below $V_{MR\_L}$	$V_{DD} > V_{DD(MIN)}$	Low
UVLO engaged	$V_{IT-(UV)} < SENSE < V_{IT+(OV)}$	Open or above $V_{MR\_H}$	$V_{POR} < V_{DD} < UVLO$	Low

### 8.4.1 Normal Operation ( $V_{DD} > V_{DD(MIN)}$ )

When the voltage on  $V_{DD}$  is greater than  $V_{DD(MIN)}$  for approximately  $(t_{SD} + t_D)$ , the  $\overline{RESET}$  output state will correspond to the SENSE pin voltage with respect to the threshold limits, when SENSE voltage is outside of threshold limits the  $\overline{RESET}$  voltage will be low ( $V_{OL}$ ).

### 8.4.2 Undervoltage Lockout ( $V_{POR} < V_{DD} < UVLO$ )

When the voltage on  $V_{DD}$  is less than the device UVLO voltage but greater than the power-on reset voltage ( $V_{POR}$ ), the  $\overline{RESET}$  pin will be held low, regardless of the voltage on SENSE pin.

### 8.4.3 Power-On Reset ( $V_{DD} < V_{POR}$ )

When the voltage on  $V_{DD}$  is lower than the required voltage ( $V_{POR}$ ) to internally pull the asserted output to GND,  $\overline{RESET}$  signal is undefined and is not to be relied upon for proper device function.



## 9 Application and Implementation

### 备注

以下应用部分中的信息不属于 TI 器件规格的范围，TI 不担保其准确性和完整性。TI 的客户应负责确定器件是否适用于其应用。客户应验证并测试其设计，以确保系统功能。

### 9.1 Application Information

#### 9.1.1 Voltage Threshold Accuracy

Voltage monitoring requirements vary depending on the voltage supply tolerance of the device being powered. Due to the high precision of the TPS3703-Q1 ( $\pm 0.7\%$  Max), the device allows for a wider supply voltage margins and threshold headroom for tight tolerance applications.

For example, take a DC/DC regulator providing power to a core voltage rail of an MCU. The MCU has a tolerance of  $\pm 5\%$  of the nominal output voltage of the DC/DC. The user sets an ideal voltage threshold of  $\pm 4\%$  which allows for  $\pm 1\%$  of threshold accuracy. Since the TPS3703-Q1 threshold accuracy is higher than  $\pm 1\%$ , the user has more supply voltage margin which can allow for a relaxed power supply design. This gives flexibility to the DC/DC to use a smaller output capacitor or inductor because of a larger voltage window for voltage ripple and transients. There is also headroom between the minimum system voltage and voltage tolerance of the MCU to ensure that the voltage supply will never be in the region of potential failure or malfunction without the TPS3703-Q1 asserting a reset signal.

图 9-1 illustrates the supply undervoltage margin and accuracy of the TPS3703-Q1 for the example explained above. Using a low accuracy supervisor will eat into the available budget for the power supply ripple and transient response. This gives less flexibility to the user and a more stringent DC/DC converter design.



图 9-1. TPS3703-Q1 Voltage Threshold Accuracy

### 9.1.2 CT Reset Time Delay

The TPS3703-Q1 features three options for setting the reset delay ( $t_D$ ): connecting a capacitor to the CT pin, connecting a pull-up resistor to VDD, and leaving the CT pin unconnected. 图 9-2 shows a schematic drawing of all three options. To determine which option is connected to the CT pin, an internal state machine controls the internal pulldown device and measures the pin voltage. This sequence of events takes 450  $\mu$ s to determine which timing option is used. Every time the voltage on the SENSE line enters the valid window ( $V_{IT-(UV)} + V_{HYS} < V_{SENSE} < V_{IT+(OV)} - V_{HYS}$ ), the state machine determines the CT option.

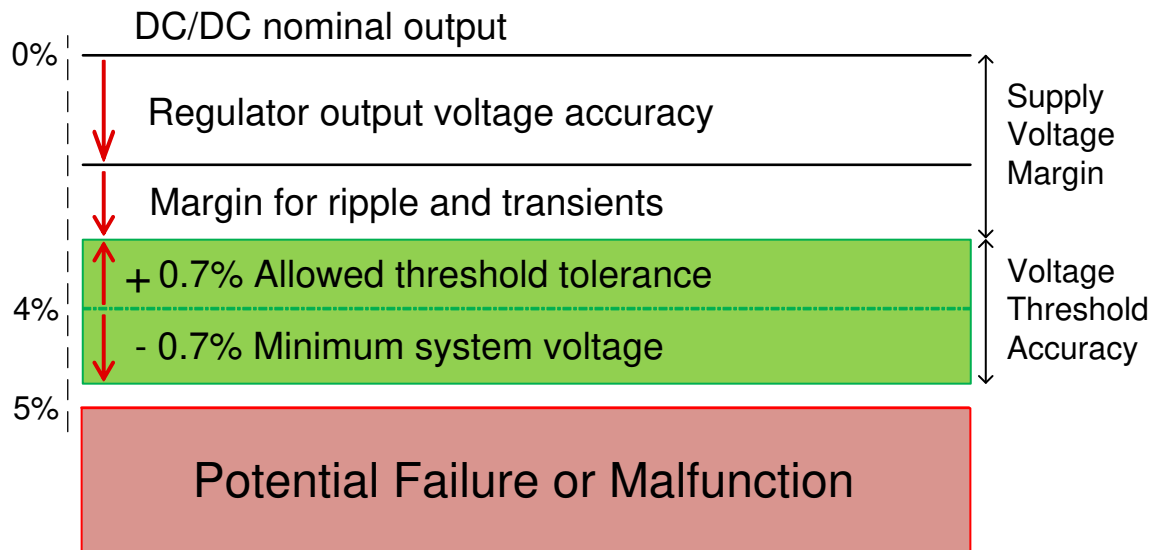

图 9-2. CT Charging Circuit

#### 9.1.2.1 Factory-Programmed Reset Delay Timing

To use the factory-programmed timing options, the CT pin must either be left unconnected or pulled up to VDD through a 10 k $\Omega$  pull-up resistor. Using these options enables a high-precision reset delay timing, as shown in 表 9-1.

表 9-1. Reset Delay Time for Factory-Programmed Reset Delay Timing

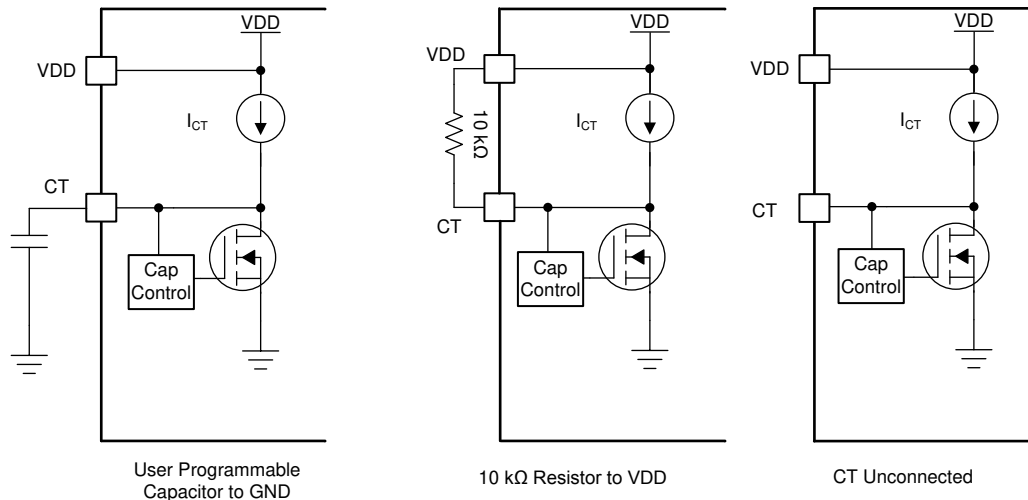
VARIANT	RESET DELAY TIME ( $t_D$ )			VALUE
	CT = Capacitor to GND	CT = Floating	CT = 10 k $\Omega$ to VDD	
TPS3703A	Programmable $t_D$	10	200	ms
TPS3703B	Programmable $t_D$	1	20	ms
TPS3703C	Programmable $t_D$	5	100	ms
TPS3703D	N/A	50	50	$\mu$ s

#### 9.1.2.2 Programmable Reset Delay-Timing

The TPS3703 reset time delay is based on internal current source ( $I_{CT}$ ) to charge external capacitor ( $C_{CT}$ ) and read capacitor voltage with internal comparator. The minimum value capacitor is 250 pF. There is no limitation on maximum capacitor the only constrain is imposed by the initial voltage of the capacitor, if CT cap is zero or near to zero then ideally there is no other constraint on the max capacitor. The typical ideal capacitor value needed for a given delay time can be calculated using 方程式 1, where  $C_{CT}$  is in nanofarads (nF) and  $t_D$  is in ms:

$$t_D = 3.066 \times C_{CT} + 0.5 \text{ ms} \quad (1)$$

To calculate the minimum and maximum-reset delay time use 方程式 2 and 方程式 3, respectively.

$$t_{D(\min)} = 2.7427 \times C_{CT} + 0.3 \text{ ms} \quad (2)$$

$$t_{D(\max)} = 3.4636 \times C_{CT} + 0.7 \text{ ms} \quad (3)$$

The slope of the equation is determined by the time the CT charging current ( $I_{CT}$ ) takes to charge the external capacitor up to the CT comparator threshold voltage ( $V_{CT}$ ). When  $\overline{\text{RESET}}$  is asserted, the capacitor is discharged through the internal CT pulldown resistor. When the  $\overline{\text{RESET}}$  conditions are cleared, the internal precision current source is enabled and begins to charge the external capacitor; when  $V_{CT} = 1.15 \text{ V}$ ,  $\overline{\text{RESET}}$  is unasserted. Note that in order to minimize the difference between the calculated  $\overline{\text{RESET}}$  delay time and the actual  $\overline{\text{RESET}}$  delay time, use a high-quality ceramic dielectric COG, X5R, or X7R capacitor and minimize parasitic board capacitance around this pin. 表 9-2 lists the reset delay time ideal capacitor values for  $C_{CT}$ .

表 9-2. Reset Delay Time for Ideal Capacitor Values

$C_{CT}$	RESET DELAY TIME ( $t_D$ ), TYPICAL
250 pF	1.27 ms
1 nF	3.57 ms
3.26 nF	10.5 ms
32.6 nF	100.45 ms
65.2 nF	200.40 ms
1 $\mu\text{F}$	3066.50 ms

### 9.1.3 RESET Latch Mode

The TPS3703-Q1 features a voltage latch mode on the  $\overline{\text{RESET}}$  pin when connecting the CT pin to common ground. A pull-down resistor is recommended to limit current consumption of the system. In latch mode, if the  $\overline{\text{RESET}}$  pin is low or triggers low, the pin will stay low regardless if  $V_{\text{SENSE}}$  is within the acceptable voltage boundaries ( $V_{IT-(UV)} < V_{\text{SENSE}} < V_{IT+(OV)}$ ). To unlatch the device provide a voltage to the CT pin that is greater than the CT pin comparator threshold voltage,  $V_{CT}$ . The  $\overline{\text{RESET}}$  pin will trigger high instantaneously without any reset delay. A voltage greater than 1.2 V is recommended to ensure a proper unlatch. Use a series resistance to limit current when an unlatch voltage is applied. For more information, 节 9.2.2 gives an example of a typical latch application.



图 9-3. RESET Latch Circuit

### 9.1.4 Adjustable Voltage Thresholds

The TPS3703-Q1 0.7% maximum accuracy allows for adjustable voltage thresholds using external resistors without adding major inaccuracies to the device. In case that the desired monitored voltage is not available, external resistor dividers can be used to set the desired voltage thresholds. 图 9-4 illustrates an example of how to adjust the voltage threshold with external resistor dividers. The resistors can be calculated depending on the desired voltage threshold and device part number. TI recommends using the 0.8V voltage threshold device such as the TPS3703B3080 because of the bypass mode of internal resistor ladder.

For example, consider a 2.0 V rail being monitored ( $V_{MON}$ ) using the TPS3703B3080 variant. Using 方程式 4,  $R_1 = 15\text{ k}\Omega$  given that  $R_2 = 10\text{ k}\Omega$ ,  $V_{MON} = 2\text{ V}$ , and  $V_{SENSE} = 0.8\text{ V}$ . This device is typically meant to monitor a 0.8 V rail with  $\pm 3\%$  voltage thresholds. This means that the device undervoltage threshold ( $V_{IT-(UV)}$ ) and overvoltage threshold ( $V_{IT+(OV)}$ ) is 0.776 V and 0.824 V respectively. Using 方程式 4,  $V_{MON-} = 1.94\text{ V}$  when  $V_{SENSE} = V_{IT-(UV)}$ . This can be denoted as  $V_{MON-}$ , the monitored undervoltage threshold where the device will assert a reset signal. Using 方程式 4 again, the monitored overvoltage threshold ( $V_{MON+}$ ) = 2.06 V when  $V_{SENSE} = V_{IT+(OV)}$ . If a wider tolerance or UV only threshold is desired, use a device variant shown on Table 7 to determine what device part number matches your application.

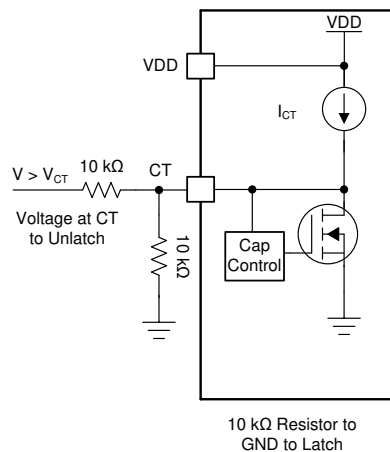
$$V_{SENSE} = V_{MON} \times (R_2 \div (R_1 + R_2)) \quad (4)$$

There are inaccuracies that must be taken into consideration while adjusting voltage thresholds. Aside from the tolerance of the resistor divider, there is an internal resistance of the SENSE pin that may affect the accuracy of the resistor divider. Although expected to be very high impedance, users are recommended to calculate the values for design specifications. The internal sense resistance ( $R_{SENSE}$ ) can be calculated by the sense voltage ( $V_{SENSE}$ ) divided by the sense current ( $I_{SENSE}$ ) as shown in 方程式 6.  $V_{SENSE}$  can be calculated using 方程式 4 depending on the resistor divider and monitored voltage.  $I_{SENSE}$  can be calculated using 方程式 5.

$$I_{SENSE} = (V_{MON} - V_{SENSE}) \div R_1 - (V_{SENSE} \div R_2) \quad (5)$$

$$R_{SENSE} = V_{SENSE} \div I_{SENSE} \quad (6)$$



图 9-4. Adjustable Voltage Threshold with External Resistor Dividers

### 9.1.5 Immunity to SENSE Pin Voltage Transients

The TPS3703-Q1 is immune to short voltage transient spikes on the input pins. Sensitivity to transients depends on both transient duration and overdrive (amplitude) of the transient.

Overdrive is defined by how much the  $V_{SENSE}$  exceeds the specified threshold, and is important to know because the smaller the overdrive, the slower the response of the outputs ( $\overline{RESET}$ ). Threshold overdrive is calculated as a percent of the threshold in question, as shown in 方程式 7:

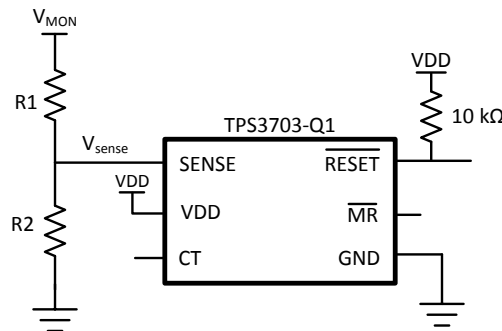
$$\text{Overdrive \%} = |(V_{SENSE} - (V_{IT-(UV)} \text{ or } V_{IT+(OV)})) / V_{IT} (\text{Nominal}) \times 100\%| \quad (7)$$

where:

- $V_{SENSE}$  is the voltage at the SENSE pin
- $V_{IT} (\text{Nominal})$  is the nominal threshold voltage
- $V_{IT-(UV)}$  and  $V_{IT+(OV)}$  represent the actual undervoltage or overvoltage tripping voltage

#### 9.1.5.1 Hysteresis

Overshoot and undervoltage comparators include built-in hysteresis that provides noise immunity and ensures stable operation. For example if the voltage on the SENSE pin falls below  $V_{IT-(UV)}$  or above  $V_{IT+(OV)}$ , then  $\overline{RESET}$  is asserted (driven low), then when the voltage on the SENSE pin is between the positive and negative threshold voltages,  $\overline{RESET}$  deasserts after the user-defined  $\overline{RESET}$  delay time. Figure 图 9-5 shows the relation between  $V_{IT-(UV)}$ ,  $V_{IT+(OV)}$  and hysteresis voltage ( $V_{HYS}$ ).



图 9-5. SENSE Pin Hysteresis

## 9.2 Typical Applications

### 9.2.1 Design 1: Multi-Rail Window Monitoring for Microcontroller Power Rails

A typical application for the TPS3703-Q1 is shown in 图 9-6. The TPS3703-Q1 is used to monitor two PMIC voltage rails that powers the core and I/O voltage of the microcontroller that requires accurate reset delay and voltage supervision. Reference design TIDA-050008 is an ADAS power reference that focuses on improved voltage supervision. It utilizes the TPS3703-Q1 to monitor the core voltage rail of a MCU similar to the circuit below.

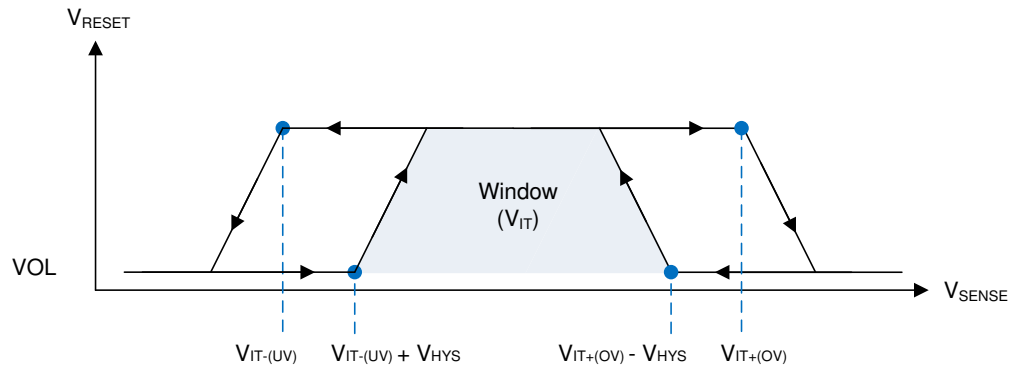

图 9-6. Two TPS3703-Q1 Monitoring Two Microcontroller Power Rails

#### 9.2.1.1 Design Requirements

表 9-3. Design Parameters

PARAMETER	DESIGN REQUIREMENT	DESIGN RESULT
Monitored rails	3.3- $V_{I/O}$ nominal, with alerts if outside of $\pm 8\%$ of 3.3 V (including device accuracy), 200 ms reset delay	Worst case $V_{IT+(OV)} = 3.554$ V (7.7%), Worst case $V_{IT-(UV)} = 3.046$ V (-7.7%)
	1.2- $V_{CORE}$ nominal, with alerts if outside of $\pm 5\%$ of 1.2 V (including device accuracy), 10 ms reset delay	Worst case $V_{IT+(OV)} = 1.256$ V (4.7%), Worst case $V_{IT-(UV)} = 1.144$ V (-4.7%)
Output logic voltage	5-V CMOS	5-V CMOS
Maximum system supervision current consumption	50 $\mu$ A	14 $\mu$ A (7 $\mu$ A Max each)

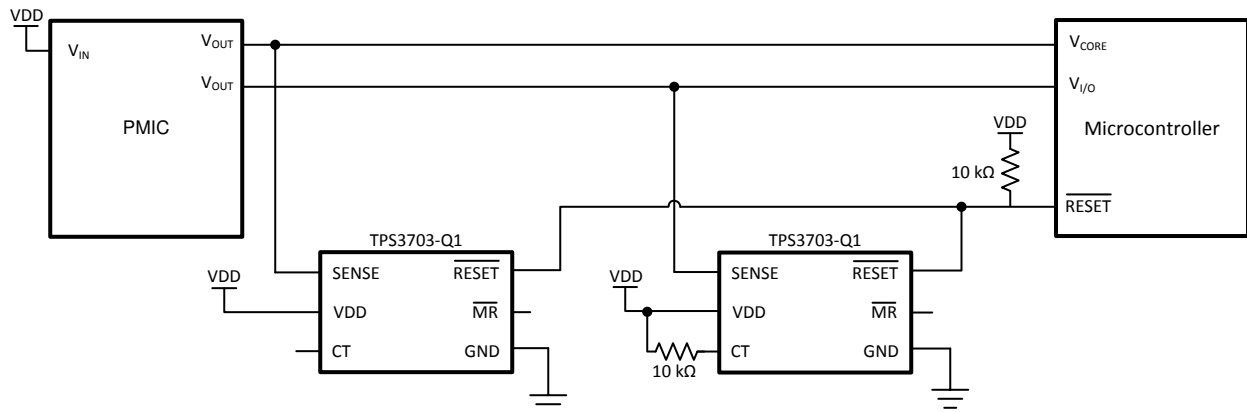
#### 9.2.1.2 Detailed Design Procedure

Determine which version of the TPS3703-Q1 best suits the monitored rail ( $V_{MON}$ ) and window tolerances found on Table 7. The TPS3703-Q1 allows overvoltage and undervoltage monitoring for precise voltage supervision of common rails between 0.5 V and 5.0 V. This application calls for very tight monitoring of the rail with only  $\pm 5\%$  of variation allowed on the 1.2V core rail. To ensure this requirement is met, the TPS3703-Q1 was chosen for its  $\pm 4\%$  thresholds. The 3.3V I/O is more flexible and can operate up to 8% variance. Since the TPS3703-Q1 comes in various tolerance options, the  $\pm 7\%$  thresholds can be chosen for this voltage rail. To calculate the worst-case for  $V_{IT+(OV)}$  and  $V_{IT-(UV)}$ , the accuracy must also be taken into account. The worst-case for  $V_{IT+(OV)}$  and  $V_{IT-(UV)}$  can be calculated shown in 方程式 8 and 方程式 9 respectively:

$$V_{IT+(OV-Worst Case)} = V_{MON} \times (\%Threshold + 0.7\%) = 1.2 \times (+4.7\%) = 1.256 \text{ V} \quad (8)$$

$$V_{IT-(UV-Worst Case)} = V_{MON} \times (\%Threshold - 0.7\%) = 1.2 \times (-4.7\%) = 1.144 \text{ V} \quad (9)$$

When the outputs switch to a high impedance state, the rise time of the  $\overline{\text{RESET}}$  pin depends on the pull-up resistance and the capacitance on that node. Choose pull-up resistors that satisfy both the downstream timing requirements and the sink current required to have a  $V_{OL}$  low enough for the application; 10 k $\Omega$  to 1 M $\Omega$  resistors are a good choice for low-capacitive loads.

### 9.2.1.3 Application Curves

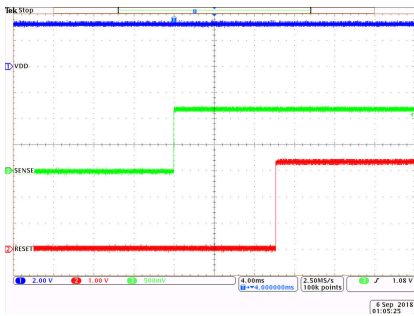

$V_{SENSE}$  Start up from 0 V to 1.2 V,  $V_{DD} = 3.3$  V, CT = OPEN  
 $V_{RESET} = V_{DD} = 3.3$  V, TPS3703A4120

图 9-7. TPS3703-Q1 SENSE Start Up Function

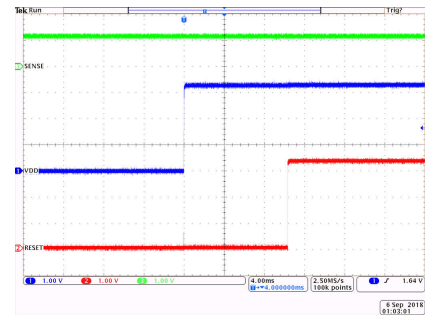

$V_{DD}$  Start up from 0 V to 3.3 V,  $V_{SENSE} = 1.2$  V, CT = OPEN  
 $V_{RESET} = V_{DD} = 3.3$  V, TPS3703A4120

图 9-8. TPS3703-Q1 VDD Start Up Function

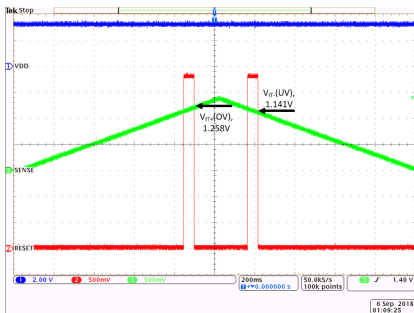

$V_{SENSE}$  ramp from 0 V to 1.4 V,  $V_{DD} = 3.3$  V, CT = OPEN  
 $V_{RESET} = V_{DD} = 3.3$  V, TPS3703A4120

图 9-9. TPS3703-Q1 Overvoltage and Undervoltage Function

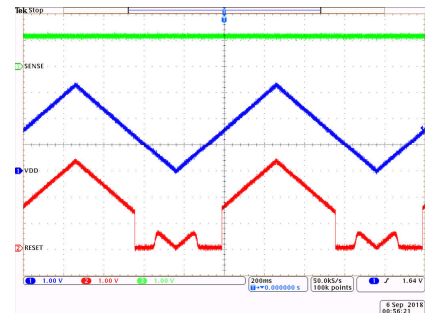

$V_{DD}$  ramp from 0 V to 3.3 V,  $V_{SENSE} = 1.2$  V, CT = OPEN  
 $V_{RESET} = V_{DD} = 3.3$  V, TPS3703A4120

图 9-10. TPS3703-Q1 VDD Ramp Up Function

## 9.2.2 Design 2: RESET Latch Mode

Another typical application for the TPS3703-Q1 is shown in 图 9-6. The TPS3703-Q1 is used in a  $\overline{\text{RESET}}$  latch output mode. In latch mode, once  $\overline{\text{RESET}}$  driven logic low, it will stay low regardless of the sense voltage. If the  $\overline{\text{RESET}}$  pin is low on start up, it will also stay low regardless of sense voltage.



图 9-11. Window Voltage Monitoring with  $\overline{\text{RESET}}$  Latch

### 9.2.2.1 Design Requirements

表 9-4. Design Parameters

PARAMETER	DESIGN REQUIREMENT	DESIGN RESULT
Monitored Rail	1.2- $V_{\text{CORE}}$ nominal, with alerts if outside of $\pm 5\%$ of 1.2 V (including device accuracy), Latch when $\overline{\text{RESET}}$ is low, until voltage is applied on CT pin.	Worst case $V_{\text{IT}+(\text{OV})} = 1.256 \text{ V}$ (4.7%), Worst case $V_{\text{IT}-(\text{UV})} = 1.144 \text{ V}$ (-4.7%)
Output logic voltage	5-V CMOS	5-V CMOS
Maximum device current consumption	15 $\mu\text{A}$	4.5 $\mu\text{A}$ (Typ), 7 $\mu\text{A}$ (Max)

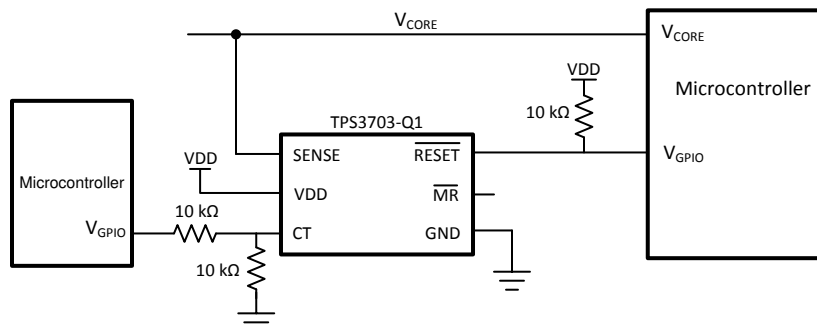
### 9.2.2.2 Detailed Design Procedure

The  $\overline{\text{RESET}}$  pin can be latched when the CT pin is connected to a common ground with a pull-down resistor. A 10 k $\Omega$  resistor is recommended to limit current consumption. To unlatch the device provide a voltage to the CT pin that is greater than the CT pin comparator threshold voltage,  $V_{\text{CT}}$ . A voltage greater than 1.15 V is recommended to ensure a proper unlatch. Use a series resistance to limit current when an unlatch voltage is applied. To go back into latch operation, disconnect the voltage on the CT pin. The  $\overline{\text{RESET}}$  pin will trigger high instantly without any reset delay.



### 9.2.2.3 Application Curves

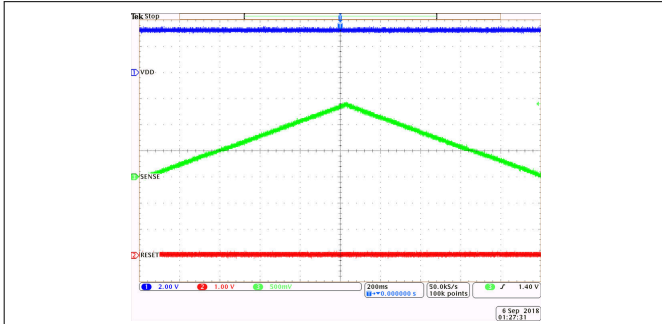

$V_{SENSE}$  ramp from 0 V to 1.4V,  $V_{DD} = 3.3$  V,  $V_{CT} = 0$  V  $V_{RESET} = V_{DD} = 3.3$  V, TPS3703A4120

**图 9-12. TPS3703-Q1 SENSE Ramp Latch Function**

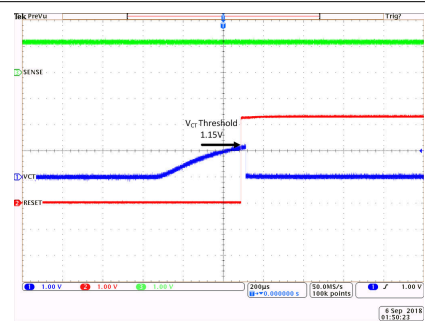

$V_{CT}$  biased at least to 1.15 V,  $V_{SENSE} = 1.2$  V  $V_{RESET} = V_{DD} = 3.3$  V, TPS3703A4120

**图 9-13. TPS3703-Q1 CT Bias Unlatch Function**

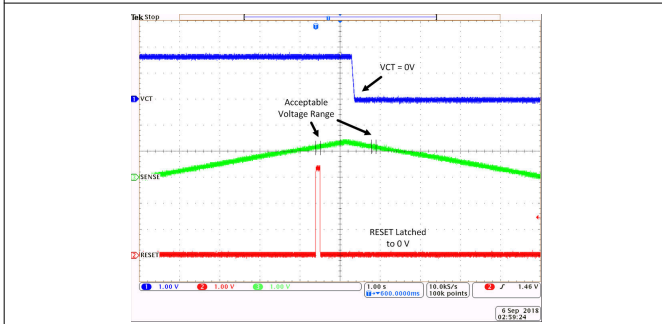

$V_{Sense}$  ramp from 0 V to 1.4 V,  $V_{DD} = 3.3$  V,  $V_{RESET} = V_{DD}$   
 $CT$  is pulled down after  $RESET$  is low,  $RESET$  becomes latched TPS3703A4120

**图 9-14. TPS3703-Q1 Overvoltage and Undervoltage Latch Function**

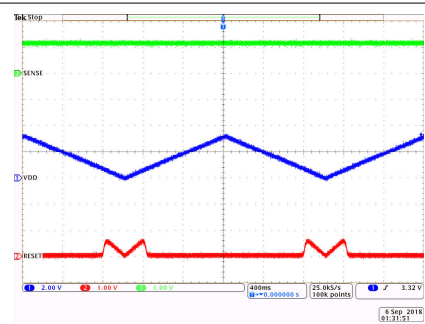

$V_{DD}$  ramp up from 0 V to 3.3 V,  $V_{SENSE} = 1.2$  V,  $CT = 0$  V  
 $V_{RESET} = V_{DD} = 3.3$  V, TPS3703A4120

**图 9-15. TPS3703-Q1 VDD Ramp Latch Function**

## 10 Power Supply Recommendations

### 10.1 Power Supply Guidelines

This device is designed to operate from an input supply with a voltage range between 1.7 V to 5.5 V. It has a 6-V absolute maximum rating on the VDD pin. It is good analog practice to place a 0.1- $\mu\text{F}$  to 1- $\mu\text{F}$  capacitor between the VDD pin and the GND pin depending on the input voltage supply noise. If the voltage supply providing power to VDD is susceptible to any large voltage transient that exceed maximum specifications, additional precautions must be taken. See [SNVA849](#) for more information.

## 11 Layout

### 11.1 Layout Guidelines

- Place the external components as close to the device as possible. This configuration prevents parasitic errors from occurring.
- Avoid using long traces for the VDD supply node. The VDD capacitor, along with parasitic inductance from the supply to the capacitor, can form an LC circuit and create ringing with peak voltages above the maximum VDD voltage.
- Avoid using long traces of voltage to the sense pin. Long traces increase parasitic inductance and cause inaccurate monitoring and diagnostics.
- Do not run sensitive analog traces in parallel with digital traces. Avoid crossing digital and analog traces if possible, and only make perpendicular crossings when absolutely necessary.

### 11.2 Layout Example



图 11-1. Recommended Layout

## 12 Device and Documentation Support

### 12.1 Device Support

#### 12.1.1 Device Nomenclature

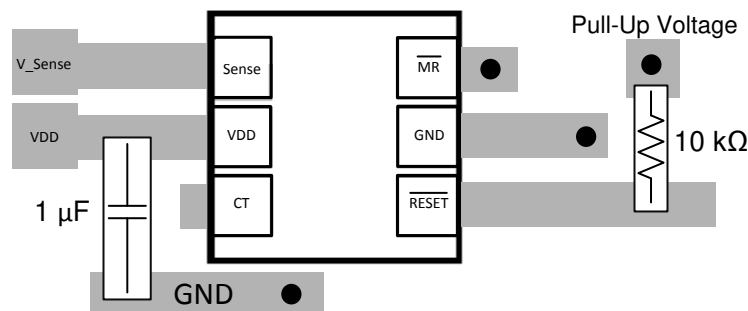
表 12-1 shows how to decode the function of the device based on its part number.

**表 12-1. Device Naming Convention**

DESCRIPTION		NOMENCLATURE	VALUE
		TPS3703	TPS3703
<b>Time delay options:</b> Every part has two fixed time delay and adjustable delay option via external capacitor Part number	Window (OV & UV)	A	CT pin open = 10 ms, CT pin tied to VDD = 200 ms CT programable with external capacitor
		B	CT pin open = 1 ms, CT pin tied to VDD = 20 ms CT programable with external capacitor
		C	CT pin open = 5 ms, CT pin tied to VDD = 100 ms CT programable with external capacitor
		D	CT pin open = 50 $\mu$ s, CT pin tied to VDD = 50 $\mu$ s CT not programable
	UV only	E	CT pin open = 10 ms, CT pin tied to VDD = 200 ms CT programable with external capacitor
		F	CT pin open = 1 ms, CT pin tied to VDD = 20 ms CT programable with external capacitor
		G	CT pin open = 5 ms, CT pin tied to VDD = 100 ms CT programable with external capacitor
		H	CT pin open = 50 $\mu$ s, CT pin tied to VDD = 50 $\mu$ s CT not programable
<b>Tolerance options:</b> Trigger or threshold voltage as a percentage of the monitored threshold voltage		3	Window threshold from nominal value = OV : 3%; UV: - 3%
		4	Window threshold from nominal value = OV : 4%; UV: - 4%
		5	Window threshold from nominal value = OV : 5%; UV: - 5%
		6	Window threshold from nominal value = OV : 6%; UV: - 6%
		7	Window threshold from nominal value = OV : 7%; UV: - 7%

**表 12-1. Device Naming Convention  
(continued)**

DESCRIPTION	NOMENCLATURE	VALUE
Nominal monitor threshold voltage option	050	0.50 V
	055	0.55 V
	060	0.60 V
	065	0.65 V
	070	0.70 V
	075	0.75 V
	080	0.80 V
	085	0.85 V
	090	0.90 V
	095	0.95 V
	100	1.00 V
	105	1.05 V
	110	1.10 V
	115	1.15 V
	120	1.20 V
	125	1.25 V
	130	1.30 V
	150	1.50 V
	180	1.80 V
	250	2.50 V
280	2.80 V	
290	2.90 V	
330	3.30 V	
500	5.00 V	
Package	DSE	WSO6 - 6 pin (1.5 mm × 1.5 mm)
Reel	R	Large reel
Automotive version	Q1	Q100 AEC

## 12.2 Documentation Support

### 12.2.1 Evaluation Module

An evaluation module (EVM) is available to assist in the initial circuit performance evaluation using the TPS3703-Q1. The *TPS3703-Q1 evaluation module (and related user guide)* can be requested at the Texas Instruments website through the product folders or purchased directly from the TI eStore .

### 12.3 接收文档更新通知

要接收文档更新通知，请导航至 [ti.com](http://ti.com) 上的器件产品文件夹。点击 *订阅更新* 进行注册，即可每周接收产品信息更改摘要。有关更改的详细信息，请查看任何已修订文档中包含的修订历史记录。

### 12.4 支持资源

[TI E2E™ 支持论坛](#) 是工程师的重要参考资料，可直接从专家获得快速、经过验证的解答和设计帮助。搜索现有解答或提出自己的问题可获得所需的快速设计帮助。

链接的内容由各个贡献者“按原样”提供。这些内容并不构成 TI 技术规范，并且不一定反映 TI 的观点；请参阅 TI 的《[使用条款](#)》。

### 12.5 Trademarks

TI E2E™ is a trademark of Texas Instruments.

所有商标均为其各自所有者的财产。

### 12.6 静电放电警告



静电放电 (ESD) 会损坏这个集成电路。德州仪器 (TI) 建议通过适当的预防措施处理所有集成电路。如果不遵守正确的处理和安装程序，可能会损坏集成电路。

ESD 的损坏小至导致微小的性能降级，大至整个器件故障。精密的集成电路可能更容易受到损坏，这是因为非常细微的参数更改都可能会导致器件与其发布的规格不相符。

### 12.7 术语表

[TI 术语表](#) 本术语表列出并解释了术语、首字母缩略词和定义。

## 13 Mechanical, Packaging, and Orderable Information

The following pages include mechanical, packaging, and orderable information. This information is the most current data available for the designated devices. This data is subject to change without notice and revision of this document. For browser-based versions of this data sheet, refer to the left-hand navigation.

**PACKAGING INFORMATION**

Orderable Device	Status (1)	Package Type	Package Drawing	Pins	Package Qty	Eco Plan (2)	Lead finish/ Ball material (6)	MSL Peak Temp (3)	Op Temp (°C)	Device Marking (4/5)	Samples
TPS3703A4085DSERQ1	ACTIVE	WSO	DSE	6	3000	RoHS & Green	NIPDAUAG	Level-1-260C-UNLIM	-40 to 125	L8	<a href="#">Samples</a>
TPS3703A4120DSERQ1	ACTIVE	WSO	DSE	6	3000	RoHS & Green	NIPDAUAG	Level-1-260C-UNLIM	-40 to 125	AB	<a href="#">Samples</a>
TPS3703A4180DSERQ1	ACTIVE	WSO	DSE	6	3000	RoHS & Green	NIPDAUAG	Level-1-260C-UNLIM	-40 to 125	AD	<a href="#">Samples</a>
TPS3703A4280DSERQ1	ACTIVE	WSO	DSE	6	3000	RoHS & Green	NIPDAUAG	Level-1-260C-UNLIM	-40 to 125	H8	<a href="#">Samples</a>
TPS3703A4330DSERQ1	ACTIVE	WSO	DSE	6	3000	RoHS & Green	NIPDAUAG	Level-1-260C-UNLIM	-40 to 125	AE	<a href="#">Samples</a>
TPS3703A5090DSERQ1	ACTIVE	WSO	DSE	6	3000	RoHS & Green	NIPDAUAG	Level-1-260C-UNLIM	-40 to 125	GW	<a href="#">Samples</a>
TPS3703A5180DSERQ1	ACTIVE	WSO	DSE	6	3000	RoHS & Green	NIPDAUAG	Level-1-260C-UNLIM	-40 to 125	GZ	<a href="#">Samples</a>
TPS3703A5290DSERQ1	ACTIVE	WSO	DSE	6	3000	RoHS & Green	NIPDAUAG	Level-1-260C-UNLIM	-40 to 125	GT	<a href="#">Samples</a>
TPS3703A7080DSERQ1	ACTIVE	WSO	DSE	6	3000	RoHS & Green	NIPDAUAG	Level-1-260C-UNLIM	-40 to 125	LD	<a href="#">Samples</a>
TPS3703A7100DSERQ1	ACTIVE	WSO	DSE	6	3000	RoHS & Green	NIPDAUAG	Level-1-260C-UNLIM	-40 to 125	LA	<a href="#">Samples</a>
TPS3703A7110DSERQ1	ACTIVE	WSO	DSE	6	3000	RoHS & Green	NIPDAUAG	Level-1-260C-UNLIM	-40 to 125	GX	<a href="#">Samples</a>
TPS3703A7120DSERQ1	ACTIVE	WSO	DSE	6	3000	RoHS & Green	NIPDAUAG	Level-1-260C-UNLIM	-40 to 125	H1	<a href="#">Samples</a>
TPS3703A7125DSERQ1	ACTIVE	WSO	DSE	6	3000	RoHS & Green	NIPDAUAG	Level-1-260C-UNLIM	-40 to 125	AC	<a href="#">Samples</a>
TPS3703A7180DSERQ1	ACTIVE	WSO	DSE	6	3000	RoHS & Green	NIPDAUAG	Level-1-260C-UNLIM	-40 to 125	H2	<a href="#">Samples</a>
TPS3703A7250DSERQ1	ACTIVE	WSO	DSE	6	3000	RoHS & Green	NIPDAUAG	Level-1-260C-UNLIM	-40 to 125	L9	<a href="#">Samples</a>
TPS3703A7280DSERQ1	ACTIVE	WSO	DSE	6	3000	RoHS & Green	NIPDAUAG	Level-1-260C-UNLIM	-40 to 125	H3	<a href="#">Samples</a>
TPS3703A7330DSERQ1	ACTIVE	WSO	DSE	6	3000	RoHS & Green	NIPDAUAG	Level-1-260C-UNLIM	-40 to 125	GV	<a href="#">Samples</a>
TPS3703B3080DSERQ1	ACTIVE	WSO	DSE	6	3000	RoHS & Green	NIPDAUAG	Level-1-260C-UNLIM	-40 to 125	BA	<a href="#">Samples</a>
TPS3703B4250DSERQ1	ACTIVE	WSO	DSE	6	3000	RoHS & Green	NIPDAUAG	Level-1-260C-UNLIM	-40 to 125	H6	<a href="#">Samples</a>
TPS3703B5180DSERQ1	ACTIVE	WSO	DSE	6	3000	RoHS & Green	NIPDAUAG	Level-1-260C-UNLIM	-40 to 125	GU	<a href="#">Samples</a>

Orderable Device	Status (1)	Package Type	Package Drawing	Pins	Package Qty	Eco Plan (2)	Lead finish/ Ball material (6)	MSL Peak Temp (3)	Op Temp (°C)	Device Marking (4/5)	Samples
TPS3703C7115DSERQ1	ACTIVE	WSO	DSE	6	3000	RoHS & Green	NIPDAUAG	Level-1-260C-UNLIM	-40 to 125	N9	<a href="#">Samples</a>
TPS3703C7500DSERQ1	ACTIVE	WSO	DSE	6	3000	RoHS & Green	NIPDAUAG	Level-1-260C-UNLIM	-40 to 125	CF	<a href="#">Samples</a>
TPS3703E4080DSERQ1	ACTIVE	WSO	DSE	6	3000	RoHS & Green	NIPDAUAG	Level-1-260C-UNLIM	-40 to 125	H7	<a href="#">Samples</a>

(1) The marketing status values are defined as follows:

**ACTIVE:** Product device recommended for new designs.

**LIFEBUY:** TI has announced that the device will be discontinued, and a lifetime-buy period is in effect.

**NRND:** Not recommended for new designs. Device is in production to support existing customers, but TI does not recommend using this part in a new design.

**PREVIEW:** Device has been announced but is not in production. Samples may or may not be available.

**OBSELETE:** TI has discontinued the production of the device.

(2) **RoHS:** TI defines "RoHS" to mean semiconductor products that are compliant with the current EU RoHS requirements for all 10 RoHS substances, including the requirement that RoHS substance do not exceed 0.1% by weight in homogeneous materials. Where designed to be soldered at high temperatures, "RoHS" products are suitable for use in specified lead-free processes. TI may reference these types of products as "Pb-Free".

**RoHS Exempt:** TI defines "RoHS Exempt" to mean products that contain lead but are compliant with EU RoHS pursuant to a specific EU RoHS exemption.

**Green:** TI defines "Green" to mean the content of Chlorine (Cl) and Bromine (Br) based flame retardants meet JS709B low halogen requirements of <=1000ppm threshold. Antimony trioxide based flame retardants must also meet the <=1000ppm threshold requirement.

(3) MSL, Peak Temp. - The Moisture Sensitivity Level rating according to the JEDEC industry standard classifications, and peak solder temperature.

(4) There may be additional marking, which relates to the logo, the lot trace code information, or the environmental category on the device.

(5) Multiple Device Markings will be inside parentheses. Only one Device Marking contained in parentheses and separated by a "-" will appear on a device. If a line is indented then it is a continuation of the previous line and the two combined represent the entire Device Marking for that device.

(6) Lead finish/Ball material - Orderable Devices may have multiple material finish options. Finish options are separated by a vertical ruled line. Lead finish/Ball material values may wrap to two lines if the finish value exceeds the maximum column width.

**Important Information and Disclaimer:**The information provided on this page represents TI's knowledge and belief as of the date that it is provided. TI bases its knowledge and belief on information provided by third parties, and makes no representation or warranty as to the accuracy of such information. Efforts are underway to better integrate information from third parties. TI has taken and continues to take reasonable steps to provide representative and accurate information but may not have conducted destructive testing or chemical analysis on incoming materials and chemicals. TI and TI suppliers consider certain information to be proprietary, and thus CAS numbers and other limited information may not be available for release.

In no event shall TI's liability arising out of such information exceed the total purchase price of the TI part(s) at issue in this document sold by TI to Customer on an annual basis.

**OTHER QUALIFIED VERSIONS OF TPS3703-Q1 :**

- Catalog : [TPS3703](#)

NOTE: Qualified Version Definitions:

- Catalog - TI's standard catalog product



## TAPE AND REEL INFORMATION

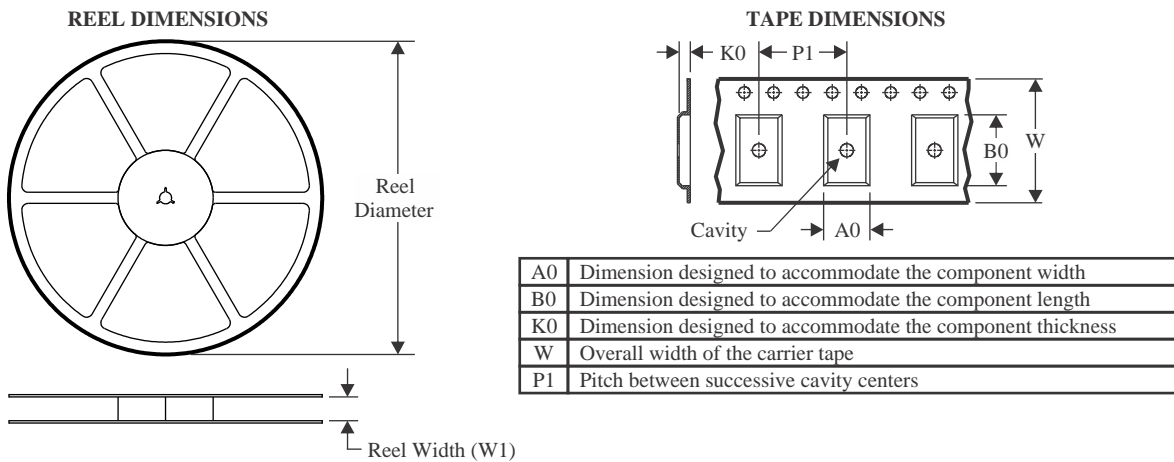

### QUADRANT ASSIGNMENTS FOR PIN 1 ORIENTATION IN TAPE



\*All dimensions are nominal

Device	Package Type	Package Drawing	Pins	SPQ	Reel Diameter (mm)	Reel Width W1 (mm)	A0 (mm)	B0 (mm)	K0 (mm)	P1 (mm)	W (mm)	Pin1 Quadrant
TPS3703A4085DSERQ1	WSO	DSE	6	3000	178.0	8.4	1.7	1.7	0.95	4.0	8.0	Q2
TPS3703A4120DSERQ1	WSO	DSE	6	3000	178.0	8.4	1.7	1.7	0.95	4.0	8.0	Q2
TPS3703A4180DSERQ1	WSO	DSE	6	3000	178.0	8.4	1.7	1.7	0.95	4.0	8.0	Q2
TPS3703A4280DSERQ1	WSO	DSE	6	3000	178.0	8.4	1.7	1.7	0.95	4.0	8.0	Q2
TPS3703A4330DSERQ1	WSO	DSE	6	3000	178.0	8.4	1.7	1.7	0.95	4.0	8.0	Q2
TPS3703A5090DSERQ1	WSO	DSE	6	3000	178.0	8.4	1.7	1.7	0.95	4.0	8.0	Q2
TPS3703A5180DSERQ1	WSO	DSE	6	3000	178.0	8.4	1.7	1.7	0.95	4.0	8.0	Q2
TPS3703A5290DSERQ1	WSO	DSE	6	3000	178.0	8.4	1.7	1.7	0.95	4.0	8.0	Q2
TPS3703A7080DSERQ1	WSO	DSE	6	3000	178.0	8.4	1.7	1.7	0.95	4.0	8.0	Q2
TPS3703A7100DSERQ1	WSO	DSE	6	3000	178.0	8.4	1.7	1.7	0.95	4.0	8.0	Q2
TPS3703A7110DSERQ1	WSO	DSE	6	3000	178.0	8.4	1.7	1.7	0.95	4.0	8.0	Q2
TPS3703A7120DSERQ1	WSO	DSE	6	3000	178.0	8.4	1.7	1.7	0.95	4.0	8.0	Q2
TPS3703A7125DSERQ1	WSO	DSE	6	3000	178.0	8.4	1.7	1.7	0.95	4.0	8.0	Q2
TPS3703A7180DSERQ1	WSO	DSE	6	3000	178.0	8.4	1.7	1.7	0.95	4.0	8.0	Q2
TPS3703A7250DSERQ1	WSO	DSE	6	3000	178.0	8.4	1.7	1.7	0.95	4.0	8.0	Q2
TPS3703A7280DSERQ1	WSO	DSE	6	3000	178.0	8.4	1.7	1.7	0.95	4.0	8.0	Q2

Device	Package Type	Package Drawing	Pins	SPQ	Reel Diameter (mm)	Reel Width W1 (mm)	A0 (mm)	B0 (mm)	K0 (mm)	P1 (mm)	W (mm)	Pin1 Quadrant
TPS3703A7330DSERQ1	WSON	DSE	6	3000	178.0	8.4	1.7	1.7	0.95	4.0	8.0	Q2
TPS3703B3080DSERQ1	WSON	DSE	6	3000	178.0	8.4	1.7	1.7	0.95	4.0	8.0	Q2
TPS3703B4250DSERQ1	WSON	DSE	6	3000	178.0	8.4	1.7	1.7	0.95	4.0	8.0	Q2
TPS3703B5180DSERQ1	WSON	DSE	6	3000	178.0	8.4	1.7	1.7	0.95	4.0	8.0	Q2
TPS3703C7500DSERQ1	WSON	DSE	6	3000	178.0	8.4	1.7	1.7	0.95	4.0	8.0	Q2
TPS3703E4080DSERQ1	WSON	DSE	6	3000	178.0	8.4	1.7	1.7	0.95	4.0	8.0	Q2

## TAPE AND REEL BOX DIMENSIONS



\*All dimensions are nominal

Device	Package Type	Package Drawing	Pins	SPQ	Length (mm)	Width (mm)	Height (mm)
TPS3703A4085DSERQ1	WSO	DSE	6	3000	205.0	200.0	33.0
TPS3703A4120DSERQ1	WSO	DSE	6	3000	205.0	200.0	33.0
TPS3703A4180DSERQ1	WSO	DSE	6	3000	205.0	200.0	33.0
TPS3703A4280DSERQ1	WSO	DSE	6	3000	205.0	200.0	33.0
TPS3703A4330DSERQ1	WSO	DSE	6	3000	205.0	200.0	33.0
TPS3703A5090DSERQ1	WSO	DSE	6	3000	205.0	200.0	33.0
TPS3703A5180DSERQ1	WSO	DSE	6	3000	205.0	200.0	33.0
TPS3703A5290DSERQ1	WSO	DSE	6	3000	205.0	200.0	33.0
TPS3703A7080DSERQ1	WSO	DSE	6	3000	205.0	200.0	33.0
TPS3703A7100DSERQ1	WSO	DSE	6	3000	205.0	200.0	33.0
TPS3703A7110DSERQ1	WSO	DSE	6	3000	205.0	200.0	33.0
TPS3703A7120DSERQ1	WSO	DSE	6	3000	205.0	200.0	33.0
TPS3703A7125DSERQ1	WSO	DSE	6	3000	205.0	200.0	33.0
TPS3703A7180DSERQ1	WSO	DSE	6	3000	205.0	200.0	33.0
TPS3703A7250DSERQ1	WSO	DSE	6	3000	205.0	200.0	33.0
TPS3703A7280DSERQ1	WSO	DSE	6	3000	205.0	200.0	33.0
TPS3703A7330DSERQ1	WSO	DSE	6	3000	205.0	200.0	33.0
TPS3703B3080DSERQ1	WSO	DSE	6	3000	205.0	200.0	33.0

---

Device	Package Type	Package Drawing	Pins	SPQ	Length (mm)	Width (mm)	Height (mm)
TPS3703B4250DSERQ1	WSON	DSE	6	3000	205.0	200.0	33.0
TPS3703B5180DSERQ1	WSON	DSE	6	3000	205.0	200.0	33.0
TPS3703C7500DSERQ1	WSON	DSE	6	3000	205.0	200.0	33.0
TPS3703E4080DSERQ1	WSON	DSE	6	3000	205.0	200.0	33.0

DSE (S-PDSO-N6)

PLASTIC SMALL OUTLINE



4207810/A 03/06

- NOTES:
- A. All linear dimensions are in millimeters.
  - B. This drawing is subject to change without notice.
  - C. Small Outline No-Lead (SON) package configuration.
  - D. This package is lead-free.

## 重要声明和免责声明

TI“按原样”提供技术和可靠性数据（包括数据表）、设计资源（包括参考设计）、应用或其他设计建议、网络工具、安全信息和其他资源，不保证没有瑕疵且不做任何明示或暗示的担保，包括但不限于对适销性、某特定用途方面的适用性或不侵犯任何第三方知识产权的暗示担保。

这些资源可供使用 TI 产品进行设计的熟练开发人员使用。您将自行承担以下全部责任：(1) 针对您的应用选择合适的 TI 产品，(2) 设计、验证并测试您的应用，(3) 确保您的应用满足相应标准以及任何其他功能安全、信息安全、监管或其他要求。

这些资源如有变更，恕不另行通知。TI 授权您仅可将这些资源用于研发本资源所述的 TI 产品的应用。严禁对这些资源进行其他复制或展示。您无权使用任何其他 TI 知识产权或任何第三方知识产权。您应全额赔偿因在这些资源的使用中对 TI 及其代表造成的任何索赔、损害、成本、损失和债务，TI 对此概不负责。

TI 提供的产品受 [TI 的销售条款](#) 或 [ti.com](#) 上其他适用条款/TI 产品随附的其他适用条款的约束。TI 提供这些资源并不会扩展或以其他方式更改 TI 针对 TI 产品发布的适用的担保或担保免责声明。

TI 反对并拒绝您可能提出的任何其他或不同的条款。

邮寄地址：Texas Instruments, Post Office Box 655303, Dallas, Texas 75265

Copyright © 2022，德州仪器 (TI) 公司

## X-ON Electronics

Largest Supplier of Electrical and Electronic Components

*Click to view similar products for [Supervisory Circuits](#) category:*

*Click to view products by [Texas Instruments](#) manufacturer:*

Other Similar products are found below :

[CAT853STBI-T3](#) [RT9818C-27GU3](#) [DS1232L](#) [NCV302HSN45T1G](#) [STM6710FWB7F](#) [PT7M6127NLTA3EX](#) [XC6118C25AGR-G](#)  
[ISL88011IH526Z-TK](#) [ISL88013IH529Z-TK](#) [ISL88705IP846Z](#) [ISL88706IP831Z](#) [ISL88708IB844Z](#) [ISL88708IP831Z](#) [TCM811MERCTR](#)  
[X40420S14-A](#) [X40421S14-C](#) [X40430S14-A](#) [X40430S14I-A](#) [X40430S14I-B](#) [X40431S14-A](#) [X40431S14-B](#) [X40431S14-C](#) [X40431S14I-A](#)  
[X40431S14I-B](#) [X40431S14I-C](#) [X4043P-2.7](#) [X4043PI-2.7](#) [X4043S8-2.7T1](#) [X4043S8IZ-2.7](#) [X4043S8IZT1](#) [X4043S8T1](#) [X4045P](#) [X4045PI](#)  
[X4045PI-2.7](#) [X4045S8-2.7T1](#) [X4045S8IZ](#) [X4045S8T1](#) [X4163P](#) [X4163P-2.7](#) [X4163PI](#) [X4163PI-2.7](#) [X4163S8](#) [X4165P](#) [X4165P-2.7](#)  
[X4165PI](#) [X4165PI-2.7](#) [X4165S8I-2.7](#) [X4283S8I](#) [X4323S8-2.7](#) [X4323S8I-2.7](#)