

TPS65186 面向 E Ink® Vizplex™ 电子纸显示屏的 PMIC

1 特性

- 面向 E Ink® Vizplex™ 电子纸显示屏的单芯片电源管理解决方案
- 通过单个低电压输入电源生成正负栅极和源级驱动电压以及背板偏置电压
- 支持 9.7 英寸及以上的显示屏尺寸
- 输入电压范围: 3V 至 6V
- 用于正电源轨基 (Positive Rail Base) 的升压转换器
- 用于负电源轨基 (Negative Rail Base) 的反向降压-升压转换器
- 两个可调节的 LDO, 用于提供源级驱动电源
 - LDO1: 15V, 120mA (VPOS)
 - LDO2: -15V, 120mA (VNEG)
- 精确输出电压跟踪
 - VPOS - VNEG = ±50mV
- 两个电荷泵, 用于提供栅极驱动电源
 - CP1: 22V, 10mA (VDDH)
 - CP2: -20V, 12mA (VEE)
- 可调节的 VCOM 驱动器, 用于提供精确的面板背板偏置电压
 - 0V 至 -5.11V
 - 精度为 ±1.5% (±10mV)
 - 9 位控制 (标称步长为 10mV)
- 集成 10Ω、3.3V 电源开关 (用于禁用 E-Ink 显示屏的系统电源轨)

2 应用

- 有源矩阵 E Ink Vizplex 显示屏的电源
- EPD 电源
- 电子书阅读器
- EPSON®S1D13522 (ISIS) 定时控制器
- EPSON®S1D13521 (宽幅印刷品) 定时控制器
- 具有集成型或软件定时控制器的应用处理器 (OMAP™)

3 说明

TPS65186 器件是一款单芯片电源, 专为为便携式电子阅读器应用中的 E Ink Vizplex 显示屏而设计。此器件支持 9.7 英寸及以上的显示屏尺寸。两个高效 DC-DC 升压转换器生成 ±16V 电压轨。这两个电压轨通过两个电荷泵分别升压至 22V 和 -20V, 从而为 Vizplex 显示屏提供栅极驱动电源。两个跟踪 LDO 生成 ±15V 源级驱动电源, 最高支持 120mA 的输出电流。所有电压轨均可通过 I²C 接口进行调节, 从而适应特定的显示屏要求。

器件信息(1)

器件型号	封装	封装尺寸 (标称值)
TPS65186	VQFN (48)	7.00mm x 7.00mm

(1) 要了解所有可用封装, 请见数据表末尾的可订购产品附录。

典型应用电路原理图

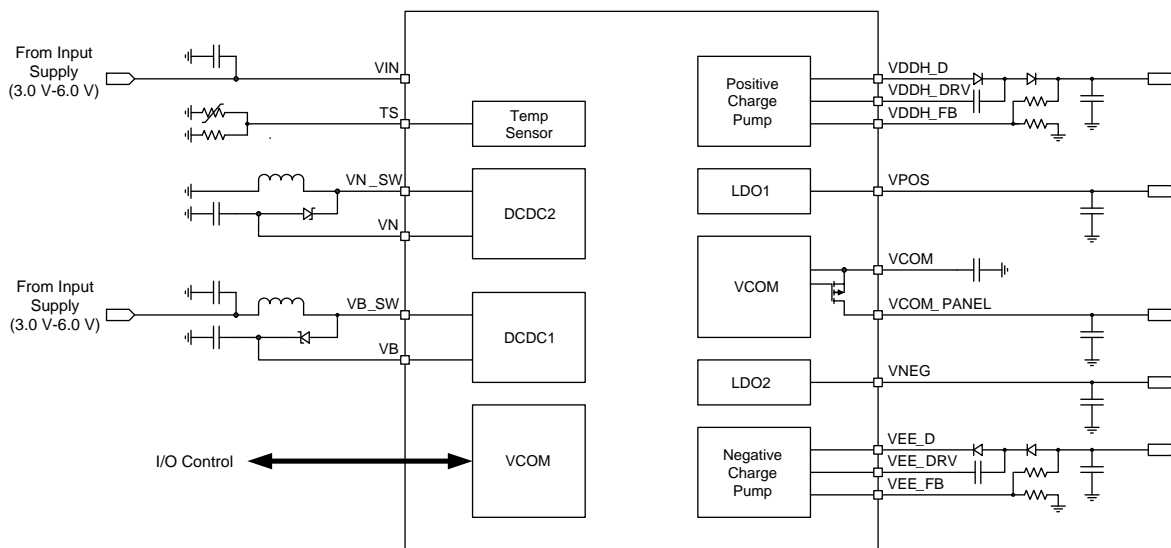

目录

<ul style="list-style-type: none"> 1 特性 1 2 应用 1 3 说明 1 4 修订历史记录 2 5 说明 (续) 3 6 Pin Configuration and Functions 3 7 Specifications 5 <ul style="list-style-type: none"> 7.1 Absolute Maximum Ratings 5 7.2 ESD Ratings 5 7.3 Recommended Operating Conditions 5 7.4 Thermal Information 6 7.5 Electrical Characteristics 6 7.6 Timing Requirements: Data Transmission 10 7.7 Typical Characteristics 12 8 Detailed Description 15 <ul style="list-style-type: none"> 8.1 Overview 15 8.2 Functional Block Diagram 16 8.3 Feature Description 17 	<ul style="list-style-type: none"> 8.4 Device Functional Modes 24 8.5 Programming 26 8.6 Register Maps 27 9 Application and Implementation 44 <ul style="list-style-type: none"> 9.1 Application Information 44 9.2 Typical Application 44 10 Power Supply Recommendations 46 11 Layout 46 <ul style="list-style-type: none"> 11.1 Layout Guidelines 46 11.2 Layout Example 46 12 器件和文档支持 47 <ul style="list-style-type: none"> 12.1 器件支持 47 12.2 社区资源 47 12.3 商标 47 12.4 静电放电警告 47 12.5 Glossary 47 13 机械、封装和可订购信息 47
---	---

4 修订历史记录

注：之前版本的页码可能与当前版本有所不同。

Changes from Original (July 2011) to Revision A	Page
<ul style="list-style-type: none"> • 已添加 ESD 额定值表, 特性 描述部分, 器件功能模式, 应用和 实施部分, 电源相关建议部分, 布局部分, 器件和文 档支持部分以及机械、封装和可订购信息部分 1 	1
<ul style="list-style-type: none"> • Changed R_{OUT} from “TBD” to “5 Ω” 8 	8

5 说明 (续)

该器件通过线性放大器来提供精确的背板偏置电压，并通过串行接口对电压值进行 9 位控制，电压值可调节范围为 0V 至 -5.11V；并且具备灌/拉电流能力，能够适应不同的显示屏条件。TPS65186 支持自动显示屏跳变电压测量，免除了在生产线上手动进行 VCOM 校准的需要。测量结果会储存在非易失性存储器中，成为新的 VCOM 上电默认值。

TPS65186 采用间距为 0.5mm 的 48 引脚 7mm × 7mm² VQFN 封装。

6 Pin Configuration and Functions

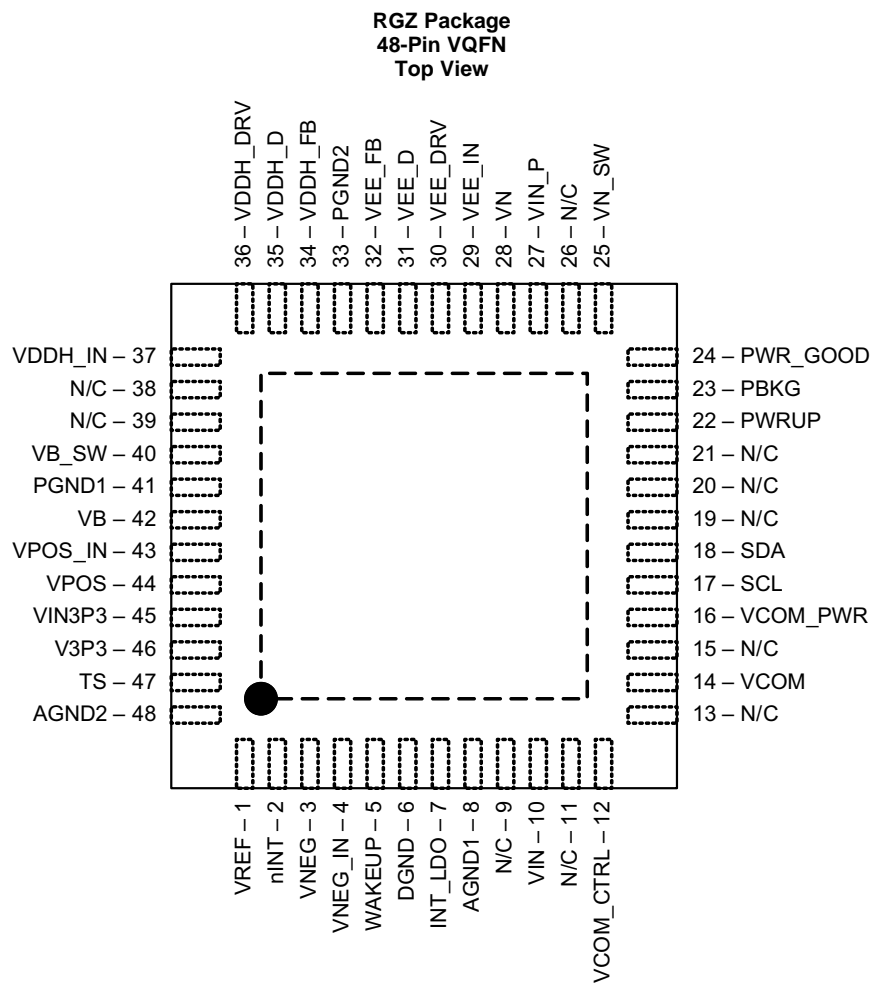

Pin Functions

PIN		I/O	DESCRIPTION
NAME	NO.		
AGND1	8	—	Analog ground for general analog circuitry
AGND2	48	—	Reference point to external thermistor and linearization resistor
DGND	6	—	Digital ground. Connect to ground plane.
INT_LDO	7	O	Filter pin for 2.7-V internal supply
nINT	2	O	Open drain interrupt pin (active low)
N/C	9, 11, 13, 15, 19, 20, 21, 26, 38, 39	—	Not internally connected

Pin Functions (continued)

PIN		I/O	DESCRIPTION
NAME	NO.		
PBKG	23	—	Die substrate. Connect to VN (–16 V) with short, wide trace. Wide copper trace will improve heat dissipation.
PGND1	41	—	Power ground for DCDC1
PGND2	33	—	Power ground for CP1 (VDDH) and CP2 (VEE) charge pumps
PWR_GOOD	24	O	Open-drain power good output pin. Pin is pulled low when one or more rails are disabled or not in regulation. DCDC1, DCDC2, and VCOM have no effect on this pin. ⁽¹⁾
PWRUP	22	I	Power-up pin. Pull this pin high to power up all output rails. ⁽¹⁾
SCL	17	I	Serial interface (I ² C) clock input
SDA	18	I/O	Serial interface (I ² C) data input/output
TS	47	I	Thermistor input pin. Connect a 10-k Ω NTC thermistor and a 43-k Ω linearization resistor between this pin and AGND.
V3P3	46	O	Output pin of 3.3-V power switch
VB	42	I	Feedback pin for boost converter (DCDC1) and supply for VPOS LDO and VDDH charge pump
VB_SW	40	O	Boost converter switch out (DCDC1)
VCOM	14	I	Filter pin for panel common-voltage driver
VCOM_CTRL	12	I	VCOM enable. Pull this pin high to enable the VCOM amplifier. When pin is pulled low and VN is enabled, VCOM discharge is enabled. ⁽²⁾
VCOM_PWR	16	I	Internal supply input pin to VCOM buffer. Connect to the output of DCDC2.
VDDH_D	35	O	Base voltage output pin for positive charge pump (CP1)
VDDH_DRV	36	O	Driver output pin for positive charge pump (CP1)
VDDH_FB	34	I	Feedback pin for positive charge pump (CP1)
VDDH_IN	37	I	Input supply pin for positive charge pump (CP1)
VEE_D	31	I	Base voltage output pin for negative charge pump (CP2)
VEE_DRV	30	O	Driver output pin for negative charge pump (CP2)
VEE_FB	32	I	Feedback pin for negative charge pump (CP2)
VEE_IN	29	I	Input supply pin for negative charge pump (CP2) (VEE)
VIN	10	I	Input power supply to general circuitry
VIN3P3	45	I	Input pin to 3.3-V power switch
VIN_P	27	I	Input power supply to inverting buck-boost converter (DCDC2)
VN	28	I	Feedback pin for inverting buck-boost converter (DCDC2) and supply for VNEG LDO and VEE charge pump
VNEG	3	O	Negative supply output pin for panel source drivers
VNEG_IN	4	I	Input pin for LDO2 (VNEG)
VN_SW	25	O	Inverting buck-boost converter switch out (DCDC2)
VREF	1	O	Filter pin for 2.25-V internal reference to ADC
VPOS	44	O	Positive supply output pin for panel source drivers
VPOS_IN	43	I	Input pin for LDO1 (VPOS)
WAKEUP	5	I	Wake-up pin (active high). Pull this pin high to wake up from sleep mode. IC accepts I ² C commands after WAKEUP pin is pulled high but power rails remain disabled until PWRUP pin is pulled high. ⁽³⁾
PowerPad	—	—	PowerPad, internally connected to PBKG. Connect to VN with short, wide trace. Wide copper trace will improve heat dissipation. PowerPad must not be connected to ground.

(1) There will be 0-ns of deglitch for PWRx.

(2) There will be 62.52- μ s of deglitch for VCOM_CTRL.

(3) There will be 93.75- μ s of deglitch for WAKEUP.

7 Specifications

7.1 Absolute Maximum Ratings

over operating free-air temperature range (unless otherwise noted) ⁽¹⁾⁽²⁾

	MIN	MAX	UNIT
Input voltage at VIN ⁽²⁾ , VIN_P, VIN3P3	-0.3	7	V
Ground pins to system ground	-0.3	0.3	V
Voltage at SDA, SCL, WAKEUP, PWRUP, VCOM_CTRL, VDDH_FB, VEE_FB, PWR_GOOD, nINT	-0.3	3.6	V
Voltage on VB, VB_SW, VPOS_IN, VDDH_IN	-0.3	20	V
Voltage on VN, VEE_IN, VCOM_PWR, VNEG_IN	-20	0.3	V
Voltage from VIN_P to VN_SW	-0.3	30	V
Peak output current	Internally limited		mA
Continuous total power dissipation	2		W
T _J Operating junction temperature	-10	125	°C
T _A Operating ambient temperature ⁽³⁾	-10	85	°C
T _{stg} Storage temperature	-65	150	°C

- (1) Stresses beyond those listed under *Absolute Maximum Ratings* may cause permanent damage to the device. These are stress ratings only, and functional operation of the device at these or any other conditions beyond those indicated under *Recommended Operating Conditions* is not implied. Exposure to absolute maximum rated conditions for extended periods may affect device reliability.
- (2) All voltage values are with respect to network ground terminal.
- (3) TI recommends that copper plane in proper size on board be in contact with die thermal pad to dissipate heat efficiently. Thermal pad is electrically connected to PBKG, which is supposed to be tied to the output of buck-boost converter. Thus wide copper trace in the buck-boost output will help heat dissipated efficiently.

7.2 ESD Ratings

		VALUE	UNIT
V _(ESD) Electrostatic discharge	Human body model (HBM), per ANSI/ESDA/JEDEC JS-001 ⁽¹⁾	±2000	V
	Charged device model (CDM), per JEDEC specification JESD22-C101 ⁽²⁾	±500	

- (1) JEDEC document JEP155 states that 500-V HBM allows safe manufacturing with a standard ESD control process.
- (2) JEDEC document JEP157 states that 250-V CDM allows safe manufacturing with a standard ESD control process.

7.3 Recommended Operating Conditions

over operating free-air temperature range (unless otherwise noted)

	MIN	NOM	MAX	UNIT
Input voltage at VIN, VIN_P, VIN3P3	3	3.7	6	V
Voltage at SDA, SCL, WAKEUP, PWRUP, VCOM_CTRL, VDDH_FB, VEE_FB, PWR_GOOD, nINT	0		3.6	V
T _A Operating ambient temperature	-10		85	°C
T _J Operating junction temperature	-10		125	°C

7.4 Thermal Information

THERMAL METRIC ⁽¹⁾		TPS65186	UNIT
		RGZ [VQFN]	
		48 PINS	
$R_{\theta JA}$	Junction-to-ambient thermal resistance	30	°C/W
$R_{\theta JC(top)}$	Junction-to-case (top) thermal resistance	15.6	°C/W
$R_{\theta JB}$	Junction-to-board thermal resistance	6.6	°C/W
ψ_{JT}	Junction-to-top characterization parameter	0.2	°C/W
ψ_{JB}	Junction-to-board characterization parameter	6.6	°C/W
$R_{\theta JC(bot)}$	Junction-to-case (bottom) thermal resistance	0.9	°C/W

(1) For more information about traditional and new thermal metrics, see the *Semiconductor and IC Package Thermal Metrics* application report, [SPRA953](#).

7.5 Electrical Characteristics

$V_{IN} = 3.7\text{ V}$, $T_A = -10^\circ\text{C}$ to 85°C , Typical values are at $T_A = 25^\circ\text{C}$ (unless otherwise noted)

PARAMETER		TEST CONDITIONS	MIN	TYP	MAX	UNIT
INPUT VOLTAGE						
V_{IN}	Input voltage range		3	3.7	6	V
V_{UVLO}	Undervoltage lockout threshold	V_{IN} falling		2.9		V
V_{HYS}	Undervoltage lockout hysteresis	V_{IN} rising		400		mV
INPUT CURRENT						
I_Q	Operating quiescent current into V_{IN}	Device switching, no load		5.5		mA
I_{STD}	Operating quiescent current into V_{IN}	Device in standby mode		130		μA
I_{SLEEP}	Shutdown current	Device in sleep mode		3.5	10	μA
INTERNAL SUPPLIES						
V_{INT_LDO}	Internal supply			2.7		V
C_{INT_LDO}	Nominal output capacitor	Capacitor tolerance $\pm 10\%$	1	4.7		μF
V_{REF}	Internal supply			2.25		V
C_{REF}	Nominal output capacitor	Capacitor tolerance $\pm 10\%$	3.3	4.7		μF
DCDC1 (POSITIVE BOOST REGULATOR)						
V_{IN}	Input voltage range		3	3.7	6	V
PG	Power good threshold	Fraction of nominal output voltage		90%		
	Power good time-out	Not tested in production		50		ms
V_{OUT}	Output voltage range			16		V
	DC set tolerance		-4.5%		4.5%	
I_{OUT}	Output current				250	mA
$R_{DS(ON)}$	MOSFET ON-resistance	$V_{IN} = 3.7\text{ V}$		350		$\text{m}\Omega$
I_{LIMIT}	Switch current limit			1.5 ⁽¹⁾		A
	Switch current accuracy		-30%		30%	
f_{SW}	Switching frequency			1		MHz
L_{DCDC1}	Inductor			2.2		μH
C_{DCDC1}	Nominal output capacitor	Capacitor tolerance $\pm 10\%$	1	2 × 4.7		μF
ESR	Output capacitor ESR			20		$\text{m}\Omega$

(1) Contact TI for 1-A, 2-A, or 2.5-A option.

Electrical Characteristics (continued)
 $V_{IN} = 3.7\text{ V}$, $T_A = -10^\circ\text{C}$ to 85°C , Typical values are at $T_A = 25^\circ\text{C}$ (unless otherwise noted)

PARAMETER		TEST CONDITIONS	MIN	TYP	MAX	UNIT
DCDC2 (INVERTING BUCK-BOOST REGULATOR)						
V_{IN}	Input voltage range		3	3.7	6	V
PG	Power good threshold	Fraction of nominal output voltage		90%		
	Power good time-out	Not tested in production		50		ms
V_{OUT}	Output voltage range			-16		V
	DC set tolerance		-4.5%		4.5%	
I_{OUT}	Output current				250	mA
$R_{DS(ON)}$	MOSFET ON-resistance	$V_{IN} = 3.7\text{ V}$		350		m Ω
I_{LIMIT}	Switch current limit			1.5 ⁽¹⁾		A
	Switch current accuracy		-30%		30%	
L_{DCDC1}	Inductor			4.7		μH
C_{DCDC1}	Nominal output capacitor	Capacitor tolerance $\pm 10\%$	1	3x4.7		μF
ESR	Capacitor ESR			20		m Ω
LDO1 (VPOS)						
V_{POS_IN}	Input voltage range		15.2	16	16.8	V
PG	Power good threshold	Fraction of nominal output voltage		90%		
	Power good time-out	Not tested in production		50		ms
V_{SET}	Output voltage set value	$V_{IN} = 16\text{ V}$, $V_{SET}[2:0] = 0x3h$ to $0x6h$	14.25	15	15	V
$V_{INTERVAL}$	Output voltage set resolution	$V_{IN} = 16\text{ V}$		250		mV
V_{OUTTOL}	Output tolerance	$V_{SET} = 15\text{ V}$, $I_{LOAD} = 20\text{ mA}$	-1%		1%	
$V_{DROPOUT}$	Dropout voltage	$I_{LOAD} = 120\text{ mA}$			250	mV
$V_{LOADREG}$	Load regulation – DC	$I_{LOAD} = 10\%$ to 90%			1%	
I_{LOAD}	Load current range				120	mA
I_{LIMIT}	Output current limit		120			mA
C_{LDO1}	Nominal output capacitor	Capacitor tolerance $\pm 10\%$	1	4.7		μF
LDO2 (VNEG)						
V_{NEG_IN}	Input voltage range		16.8	16	-15.2	V
PG	Power good threshold	Fraction of nominal output voltage		90%		
	Power good time-out	Not tested in production		50		ms
V_{SET}	Output voltage set value	$V_{IN} = -16\text{ V}$, $V_{SET}[2:0] = 0x3h$ to $0x6h$	-15	-15	-14.25	V
$V_{INTERVAL}$	Output voltage set resolution	$V_{IN} = -16\text{ V}$		250		mV
V_{OUTTOL}	Output tolerance	$V_{SET} = -15\text{ V}$, $I_{LOAD} = -20\text{ mA}$	-1%		1%	
$V_{DROPOUT}$	Dropout voltage	$I_{LOAD} = 120\text{ mA}$			250	mV
$V_{LOADREG}$	Load regulation – DC	$I_{LOAD} = 10\%$ to 90% of $I_{LOAD,MAX}$			1%	
I_{LOAD}	Load current range				120	mA
I_{LIMIT}	Output current limit		120			mA
C_{LDO2}	Nominal output capacitor	Capacitor tolerance $\pm 10\%$	1	4.7		μF

Electrical Characteristics (continued)
 $V_{IN} = 3.7\text{ V}$, $T_A = -10^\circ\text{C}$ to 85°C , Typical values are at $T_A = 25^\circ\text{C}$ (unless otherwise noted)

PARAMETER		TEST CONDITIONS	MIN	TYP	MAX	UNIT
LD01 (POS) AND LDO2 (VNEG) TRACKING						
V_{DIFF}	Difference between VPOS and VNEG	$V_{SET} = \pm 15\text{ V}$, $I_{LOAD} = \pm 20\text{ mA}$, 0°C to 60°C	-50		50	mV
VCOM DRIVER						
I_{VCOM}	Drive current			15		mA
V_{COM}	Allowed operating range	Outside this range VCOM is shut down and VCOMF interrupt is set	-5.5		1	V
	Accuracy	$V_{COM}[8:0] = 0x07Dh$ (-1.25 V), $V_{IN} = 3.4\text{ V}$ to 4.2 V , no load	-0.8%		0.8%	
		$V_{COM}[8:0] = 0x07Dh$ (-1.25 V), $V_{IN} = 3\text{ V}$ to 6 V , no load	-1.5%		1.5%	
	Output voltage range		-5.11		0	V
	Resolution	1LSB		10		mV
	Max number of EEPROM writes	V_{COM} calibration			100	
R_{OUT}	Output impedance	$V_{COM_CTRL} = \text{high}$, $Hi-Z = 0$		5		Ω
R_{IN}	Input impedance, HiZ state	$HiZ = 1$	150			M Ω
C_{VCOM}	Nominal output capacitor	Capacitor tolerance $\pm 10\%$	3.3	4.7		μF
CP1 (VDDH) CHARGE PUMP						
V_{DDH_IN}	Input voltage range		15.2	16	16.8	V
PG	Power good threshold	Fraction of nominal output voltage		90%		
	Power good time-out	Not tested in production		50		ms
V_{FB}	Feedback voltage			0.998		V
	Accuracy	$I_{LOAD} = 2\text{ mA}$	-2%		2%	
V_{DDH_OUT}	Output voltage range	$V_{SET} = 22\text{ V}$, $I_{LOAD} = 2\text{ mA}$	21	22	23	V
I_{LOAD}	Load current range				10	mA
f_{SW}	Switching frequency			560		kHz
C_D	Driver capacitor			10		nF
C_O	Output capacitor		1	2.2		μF
CP2 (VEE) NEGATIVE CHARGE PUMP						
V_{EE_IN}	Input voltage range		16.8	-16	-15.2	V
PG	Power good threshold	Fraction of nominal output voltage		90%		
	Power good time-out	Not tested in production		50		ms
V_{FB}	Feedback voltage			-0.994		V
	Accuracy	$I_{LOAD} = 2\text{ mA}$	-2%		2%	
V_{EE_OUT}	Output voltage range	$V_{SET} = -20\text{ V}$, $I_{LOAD} = 3\text{ mA}$	-21	-20	-19	V
I_{LOAD}	Load current range				12	mA
f_{SW}	Switching frequency			560		kHz
C_D	Driver capacitor			10		nF
C_O	Nominal output capacitor	Capacitor tolerance $\pm 10\%$	1	2.2		μF

Electrical Characteristics (continued)
 $V_{IN} = 3.7\text{ V}$, $T_A = -10^\circ\text{C}$ to 85°C , Typical values are at $T_A = 25^\circ\text{C}$ (unless otherwise noted)

PARAMETER		TEST CONDITIONS	MIN	TYP	MAX	UNIT
VIN3P3 TO V3P3 SWITCH						
$R_{DS(ON)}$	MOSFET ON-resistance	VIN3P3 = 3.3 V, $I_D = 10\text{ mA}$ Over full temperature range		10.5		Ω
		VIN3P3 = 2.7 V, $I_D = 10\text{ mA}$ Over full temperature range		12.3		
R_{DIS}	Discharge impedance to ground	V3P3EN = 0	800	1000	1200	Ω
THERMISTOR MONITOR⁽²⁾						
A_{TMS}	Temperature to voltage ratio	Not tested in production		-0.0161		$V/^\circ\text{C}$
Offset _{TMS}	Offset	Temperature = 0°C		1.575		V
V_{TMS_HOT}	Temp hot trip voltage (T = 50°C)	TEMP_HOT_SET = 0x8C		0.768		V
V_{TMS_COOL}	Temp hot escape voltage (T = 45°C)	TEMP_COOL_SET = 0x82		0.845		V
V_{TMS_MAX}	Maximum input level			2.25		V
R_{NTC_PU}	Internal pullup resistor			7.307		$k\Omega$
R_{LINEAR}	External linearization resistor			43		$k\Omega$
ADC _{RES}	ADC resolution	Not tested in production, 1 bit		16.1		mV
ADC _{DEL}	ADC conversion time	Not tested in production		19		μs
TMST _{TOL}	Accuracy	Not tested in production	-1		1	LSB
LOGIC LEVELS AND TIMING CHARACTERISTICS (SCL, SDA, nINT, PWR_GOOD, PWRUP)						
V_{OL}	Output low threshold level	$I_O = 3\text{ mA}$, sink current (SDA, nINT, PWR_GOOD)			0.4	V
V_{IL}	Input low threshold level				0.4	V
V_{IH}	Input high threshold level		1.2			V
$I_{(bias)}$	Input bias current	$V_{IO} = 1.8\text{ V}$			1	μA
$t_{degitch}$	Deglitch time, WAKEUP pin	Not tested in production		500		μs
	Deglitch time, PWRUP pin	Not tested in production		400		
f_{SCL}	SCL clock frequency				400	kHz
	I ² C slave address	7-bit address			$0 \times 48h^{(3)}$	
OSCILLATOR						
f_{OSC}	Oscillator frequency			9		MHz
	Frequency accuracy	$T_A = -40^\circ\text{C}$ to 85°C	-10%		10%	
THERMAL SHUTDOWN						
T_{SHTDWN}	Thermal trip point			150		$^\circ\text{C}$
	Thermal hysteresis			20		$^\circ\text{C}$

(2) 10-k Ω Murata NCP18XH103F03RB thermistor (1%) in parallel with a linearization resistor (43 k Ω , 1%) are used at TS pin for panel temperature measurement.

(3) Contact TI for alternate address of $0 \times 68h$.

7.6 Timing Requirements: Data Transmission

 $V_{BAT} = 3.6\text{ V} \pm 5\%$, $T_A = 25^\circ\text{C}$, $C_L = 100\text{ pF}$ (unless otherwise noted)

		MIN	NOM	MAX	UNIT
$f_{(SCL)}$	Serial clock frequency	100		400	kHz
$t_{HD;STA}$	Hold time (repeated) START condition. After this period, the first clock pulse is generated.	SCL = 100 kHz	4		μs
		SCL = 400 kHz	600		ns
t_{LOW}	LOW period of the SCL clock	SCL = 100 kHz	4.7		μs
		SCL = 400 kHz	1.3		
t_{HIGH}	HIGH period of the SCL clock	SCL = 100 kHz	4		μs
		SCL = 400 kHz	600		ns
$t_{SU;STA}$	Setup time for a repeated START condition	SCL = 100 kHz	4.7		μs
		SCL = 400 kHz	600		ns
$t_{HD;DAT}$	Data hold time	SCL = 100 kHz	0	3.45	μs
		SCL = 400 kHz	0	900	ns
$t_{SU;DAT}$	Data setup time	SCL = 100 kHz	250		ns
		SCL = 400 kHz	100		
t_r	Rise time of both SDA and SCL signals	SCL = 100 kHz		1000	ns
		SCL = 400 kHz		300	
t_f	Fall time of both SDA and SCL signals	SCL = 100 kHz		300	ns
		SCL = 400 kHz		300	
$t_{SU;STO}$	Setup time for STOP condition	SCL = 100 kHz	4		μs
		SCL = 400 kHz	600		ns
t_{BUF}	Bus Free Time Between Stop and Start Condition	SCL = 100 kHz	4.7		μs
		SCL = 400 kHz	1.3		
t_{SP}	Pulse width of spikes that must be suppressed by the input filter	SCL = 100 kHz	n/a	n/a	ns
		SCL = 400 kHz	0	50	
C_b	Capacitive load for each bus line	SCL = 100 kHz		400	pF
		SCL = 400 kHz		400	

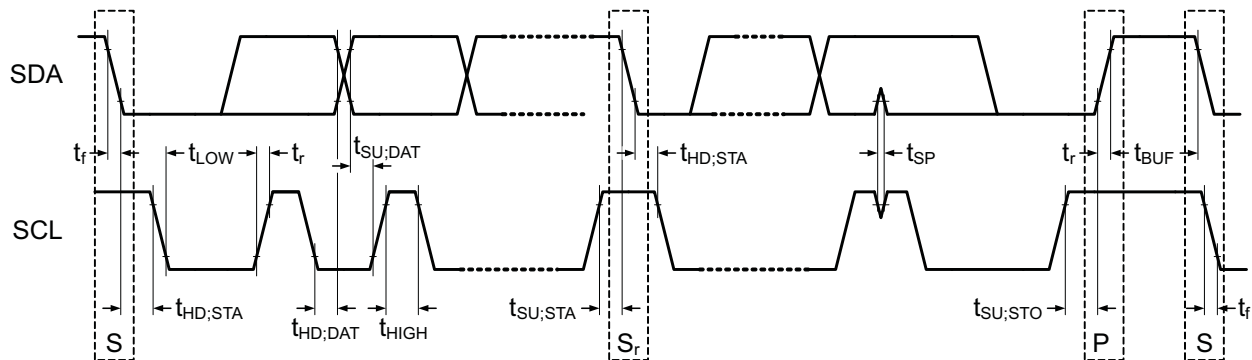
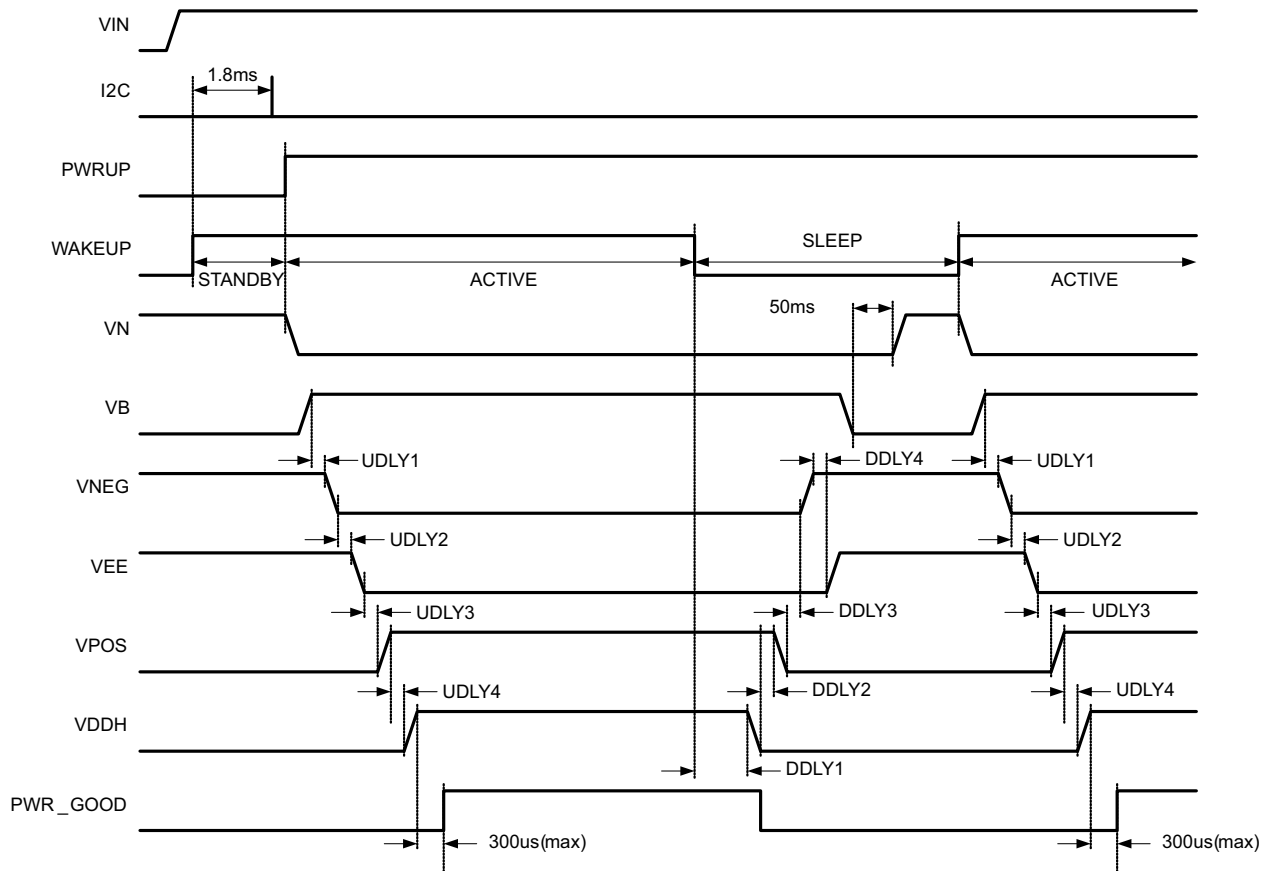

Figure 1. I²C Data Transmission Timing



Minimum delay time between WAKEUP rising edge and IC ready to accept I²C transaction.

In this example, the first power-up sequence is started by pulling the PWRUP pin high (rising edge). Power-down is initiated by pulling the WAKEUP pin low (device enters sleep mode). The second power-up sequence is initiated by pulling the WAKEUP pin high while the PWRUP pin is also high (power up from sleep to active).

Figure 2. Power-Up and Power-Down Timing Diagram

7.7 Typical Characteristics

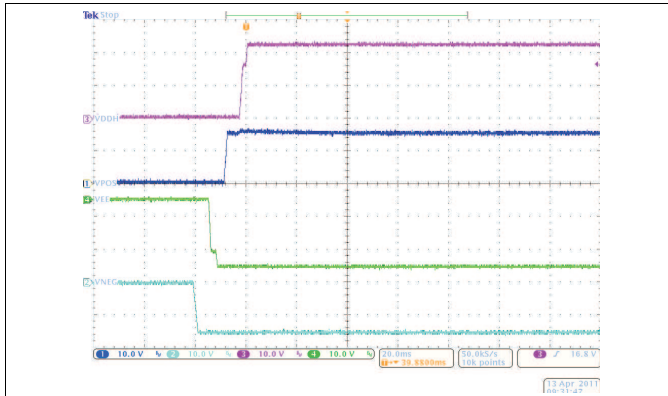

Figure 3. Default Power-Up Sequence

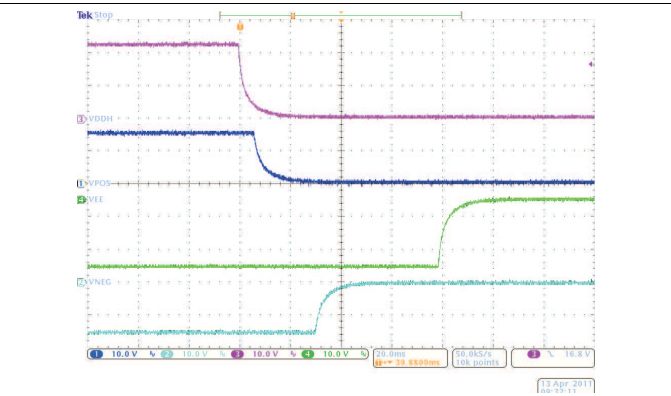
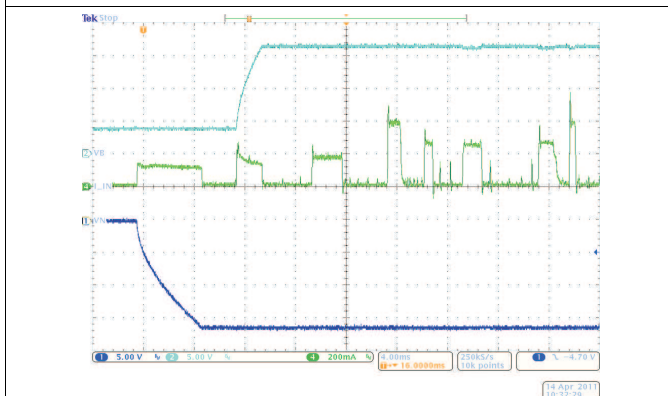
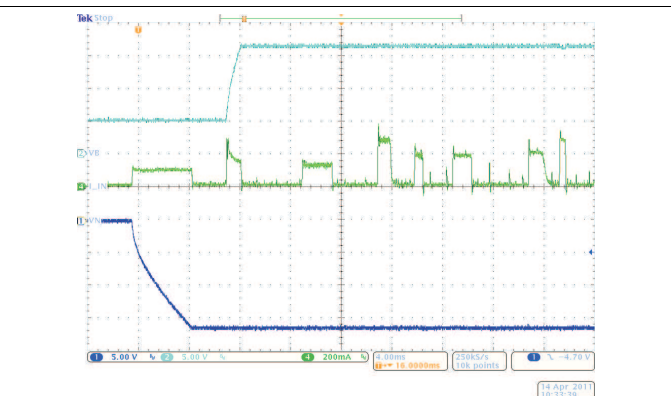

Figure 4. Default Power-Down Sequence



$V_{IN} = 3.7\text{ V}$ $C_{IN} = 100\ \mu\text{F}$

Figure 5. Inrush Current



$V_{IN} = 5\text{ V}$ $C_{IN} = 100\ \mu\text{F}$

Figure 6. Inrush Current

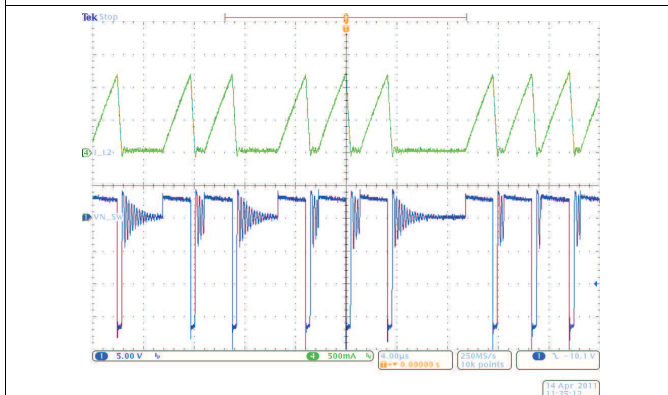

$V_{IN} = 3\text{ V}$ $R_{LOAD, VPOS} = 330\ \Omega$ $R_{LOAD, VNEG} = 330\ \Omega$
No Load on VDDH, VEE

Figure 7. Switching Waveforms, VN

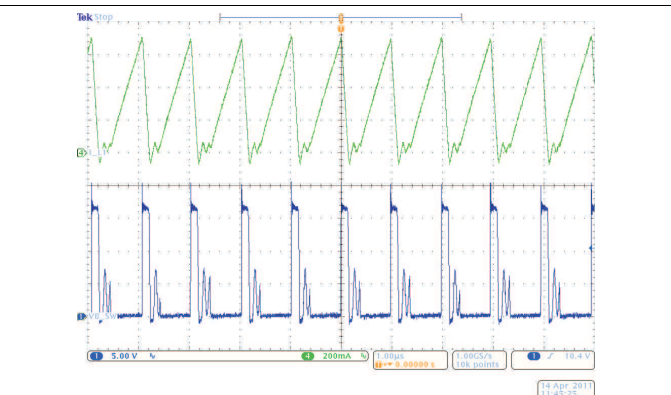

$V_{IN} = 3\text{ V}$ $R_{LOAD, VPOS} = 330\ \Omega$ $R_{LOAD, VNEG} = 330\ \Omega$
No Load on VDDH, VEE

Figure 8. Switching Waveforms, VB

Typical Characteristics (continued)

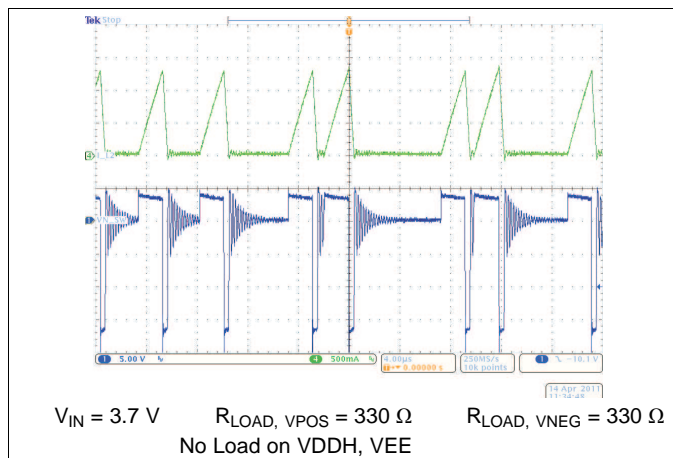

Figure 9. Switching Waveforms, VN

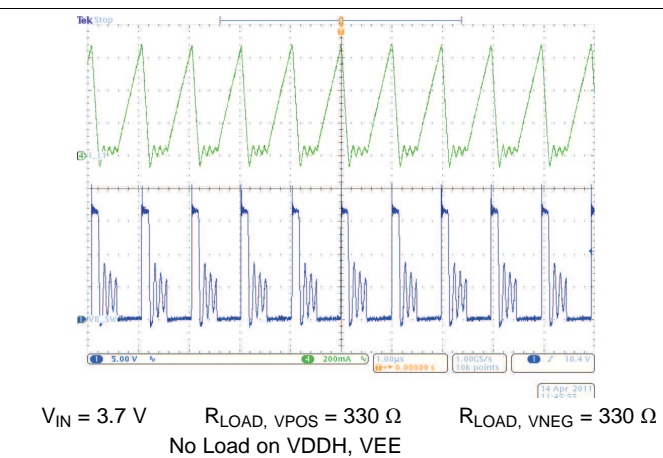

Figure 10. Switching Waveforms, VB

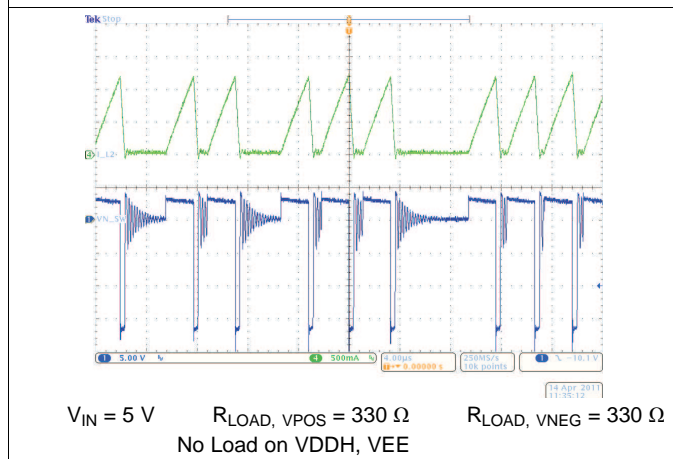

Figure 11. Switching Waveforms, VN

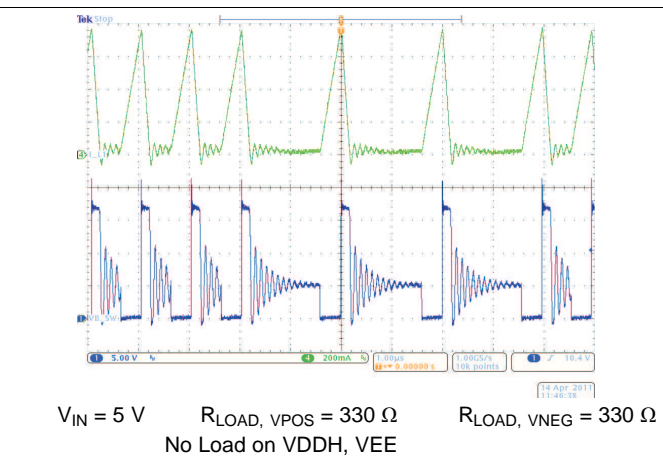

Figure 12. Switching Waveforms, VB

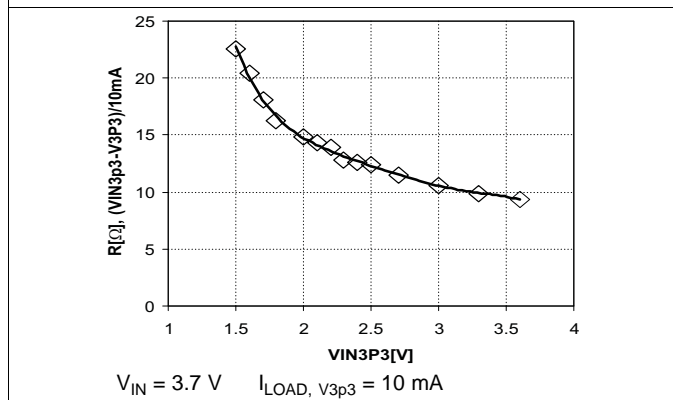

Figure 13. 3p3V Switch Impedance

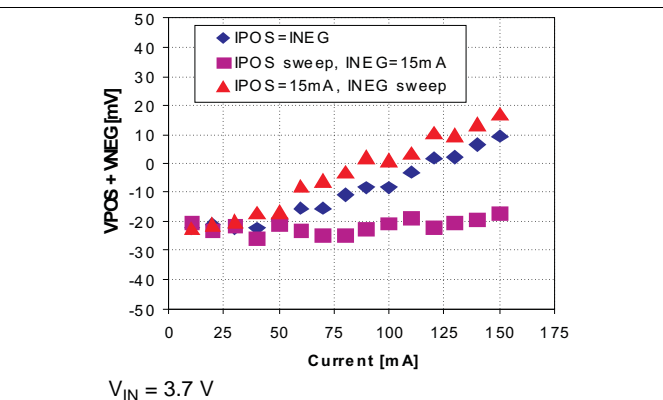

Figure 14. Source Driver Supply Tracking

Typical Characteristics (continued)

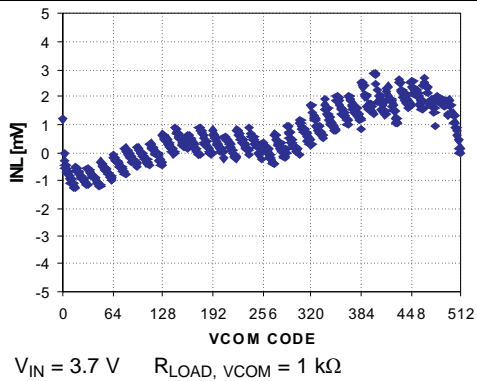

Figure 15. VCOM Integrated Non-Linearity

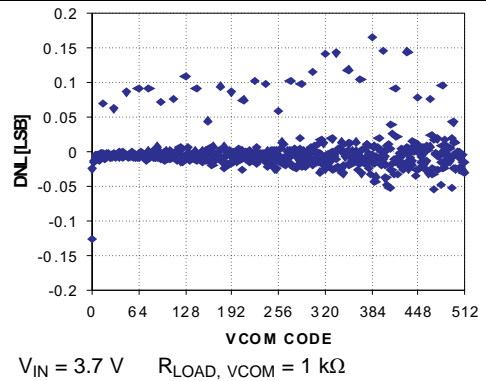

Figure 16. VCOM Differential Non-Linearity

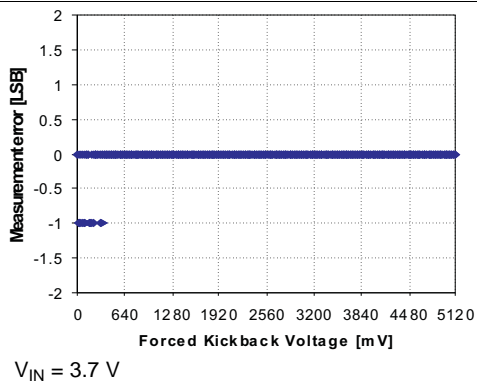

Figure 17. Kickback Voltage Measurement Error

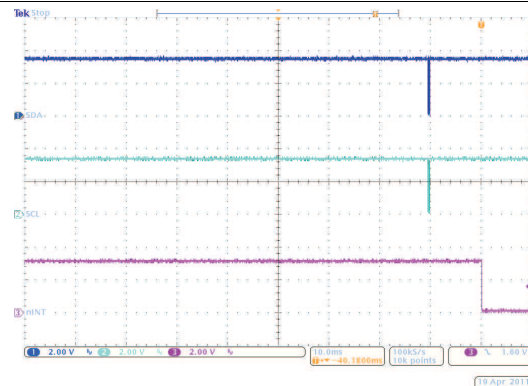

Figure 18. Kickback Voltage Measurement Timing

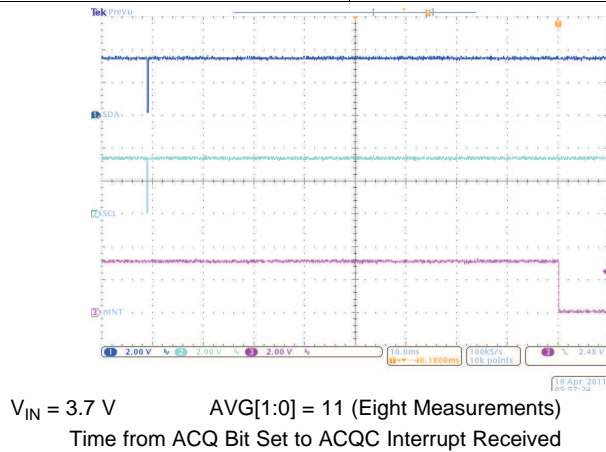

Figure 19. Kickback Voltage Measurement Timing

8 Detailed Description

8.1 Overview

The TPS65186 device provides two adjustable LDOs, inverting buck-boost converter, boost converter, thermistor monitoring, and flexible power-up and power-down sequencing. The system can be supplied by a regulated input voltage ranging from 3 V to 6 V. The device is characterized across a -10°C to 85°C temperature range, best suited for personal electronic applications.

The I²C interface provides comprehensive features for using the TPS65186. All rails can be enabled or disabled. Power-up and power-down sequences can also be programmed through the I²C interface, as well as thermistor configuration and interrupt configuration. Voltage adjustment can also be controlled by the I²C interface.

The adjustable LDOs can supply up to 120 mA of current. The default output voltages for each LDO can be adjusted through the I²C interface. LDO1 (VPOS) and LDO2 (VNEG) track each other in a way that they are of opposite sign but same magnitude. The sum of VLDO1 and VLDO2 is guaranteed to be less than 50 mV.

There are two charge pumps: VDDH and VEE 10 mA and 12 mA respectively. These charge pumps boost the DC-DC boost converters $\pm 16\text{-V}$ rails to provide a gate channel supply.

The power good functionality is open-drain output, if any of the four power rails (CP1, CP2, LDO1, LDO2) are not in regulation, encounters a fault, or is disabled the pin is pulled low. PWR_GOOD remains low if one of the rails is not enabled by the host and only after all rails are in regulation PWR_GOOD is released to Hi-Z state (pulled up by external resistor).

The TPS65186 provides circuitry to bias and measure an external NTC to monitor the display panel temperature in a range from -10°C to 85°C with an accuracy of $\pm 1^{\circ}\text{C}$ from 0°C to 50°C . Temperature measurement are triggered by the controlling host and the last temperature reading is always stored in the TMST_VALUE register. Interrupts are issued when the temperature exceeds the programmable HOT, or drops below the programmable COLD threshold, or when the temperature has changed by more than a user-defined threshold from the baseline value.

This device is offered in a 48-Pin, 0.5-mm Pitch, 7 mm × 7 mm × 0.9 mm (VQFN) RGZ package.

8.2 Functional Block Diagram

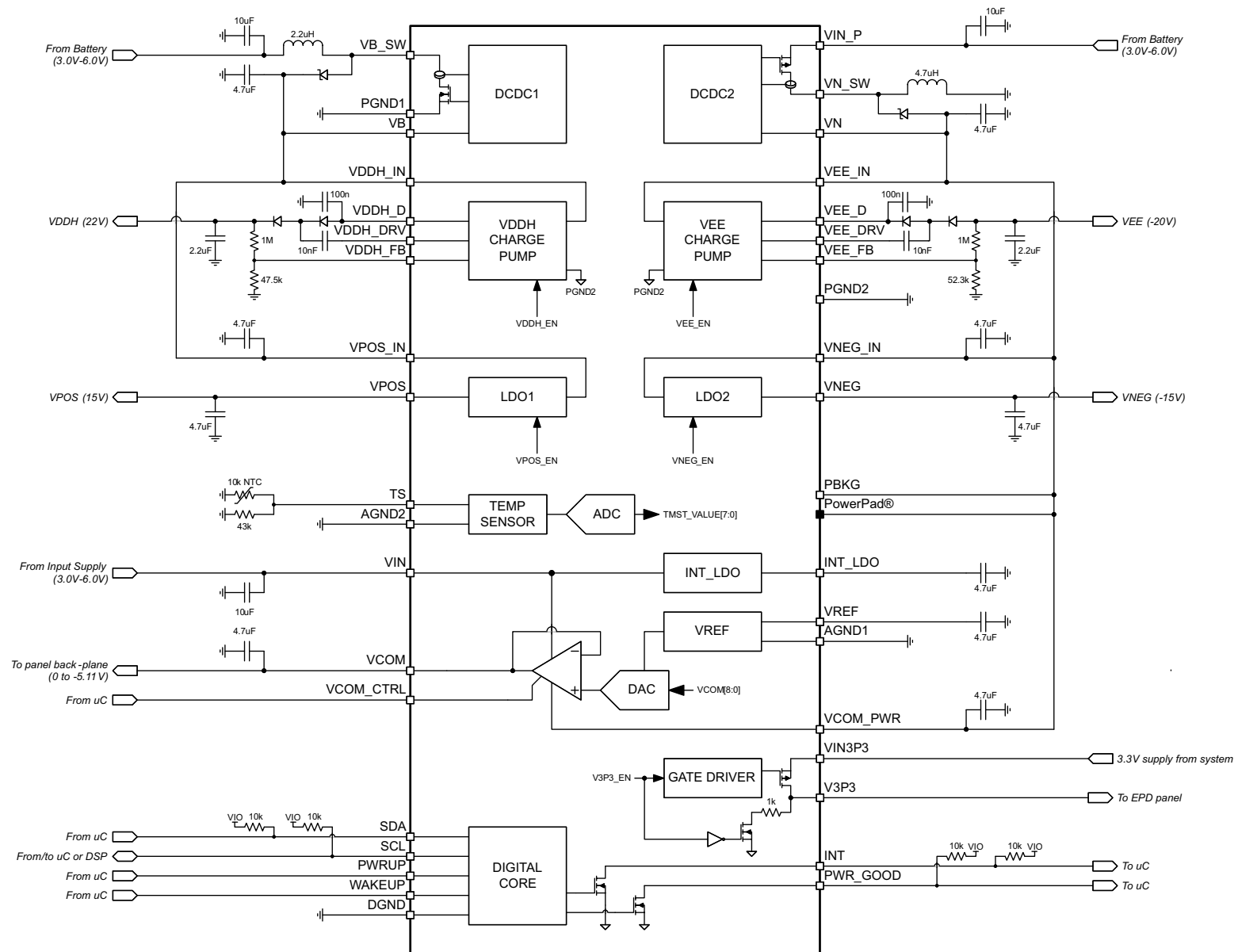

8.3 Feature Description

8.3.1 Wake-Up and Power-Up Sequencing

The power-up and power-down order and timing is defined by user register settings. The default settings support the E Ink Vizplex panel and typically do not need to be changed.

In SLEEP mode the TPS65186 is completely turned off, the I²C registers are reset, and the device does not accept any I²C transaction. Pull the WAKEUP pin high with the PWRUP pin low and the device enters STANDBY mode that enables the I²C interface. Write to the UPSEQ0 register to define the order in which the output rails are enabled at power-up and to the UPSEQ1 registers to define the power-up delays between rails. Finally, set the ACTIVE bit in the ENABLE register to 1 to execute the power-up sequence and bring up all power rails. Alternatively, pull the PWRUP pin high (rising edge).

After the ACTIVE bit has been set, the negative boost converter (VN) is powered up first, followed by the positive boost (VB). The positive boost enable is gated by the internal power-good signal of the negative boost. Once VB is in regulation, it issues an internal power-good signal and after delay time UDLY1 has expired, STROBE1 is issued. The rail assigned to STROBE1 will power up next and after its power-good signal has been asserted and delay time UDLY2 has expired, STROBE2 is issued. The sequence continues until STROBE4 has occurred and the last rail has been enabled.

To power down the device, set the STANDBY bit of the ENABLE register to 1 or pull the PWRUP pin low (falling edge) and the TPS65186 will power down in the order defined by DWNSEQx registers. The delay times DDLY2, DDLY3, and DDLY4 are weighted by a factor of DFCTR which allows the user to space out the power down of the rails to avoid crossing during discharge. DFCTR is located in register DWNSEQ1. The positive boost (VB) is shut down together with the last rail at STROBE4. However, the negative boost (VN) remains up and running for another 50 ms. Then VN is powered down and the device enters STANDBY or SLEEP mode, depending on the WAKEUP pin.

If either the ACTIVE bit is set or the PWRUP pin is pulled high while the device is powering down, the power-down sequence (STROBE1-4) is completed first, followed by a power-up sequence. VB and VN may or may not be powered down and depending on the relative timing of STROBE4 to the new power-up event.

During power-up, if the STANDBY bit is set or the PWRUP pin is pulled low, the power-up sequence is aborted and the power-down sequence starts immediately.

8.3.2 Dependencies Between Rails

Charge pumps, LDOs, and VCOM driver are dependent on the positive and inverting buck-boost converters and several dependencies exist that affect the power-up sequencing. These dependencies are the following:

- Inverting buck-boost (DCDC2) must be in regulation before positive boost (DCDC1) can be enabled. Internally, DCDC1 enable is gated by DCDC2 power good.
- Positive boost (DCDC1) must be in regulation before LDO2 (VNEG) can be enabled. Internally LDO2 enable is gated DCDC1 power good.
- Positive boost (DCDC1) must be in regulation before VCOM can be enabled. Internally VCOM enable is gated by DCDC1 power good.
- Positive boost (DCDC1) must be in regulation before negative charge pump (CP2) can be enabled. Internally CP2 enable is gated by DCDC1 power good.
- Positive boost (DCDC1) must be in regulation before positive charge pump (CP1) can be enabled. Internally CP1 enable is gated by DCDC1 power good.
- LDO2 must be in regulation before LDO1 can be enabled. Internally LDO1 enable is gated by LDO2 power good.

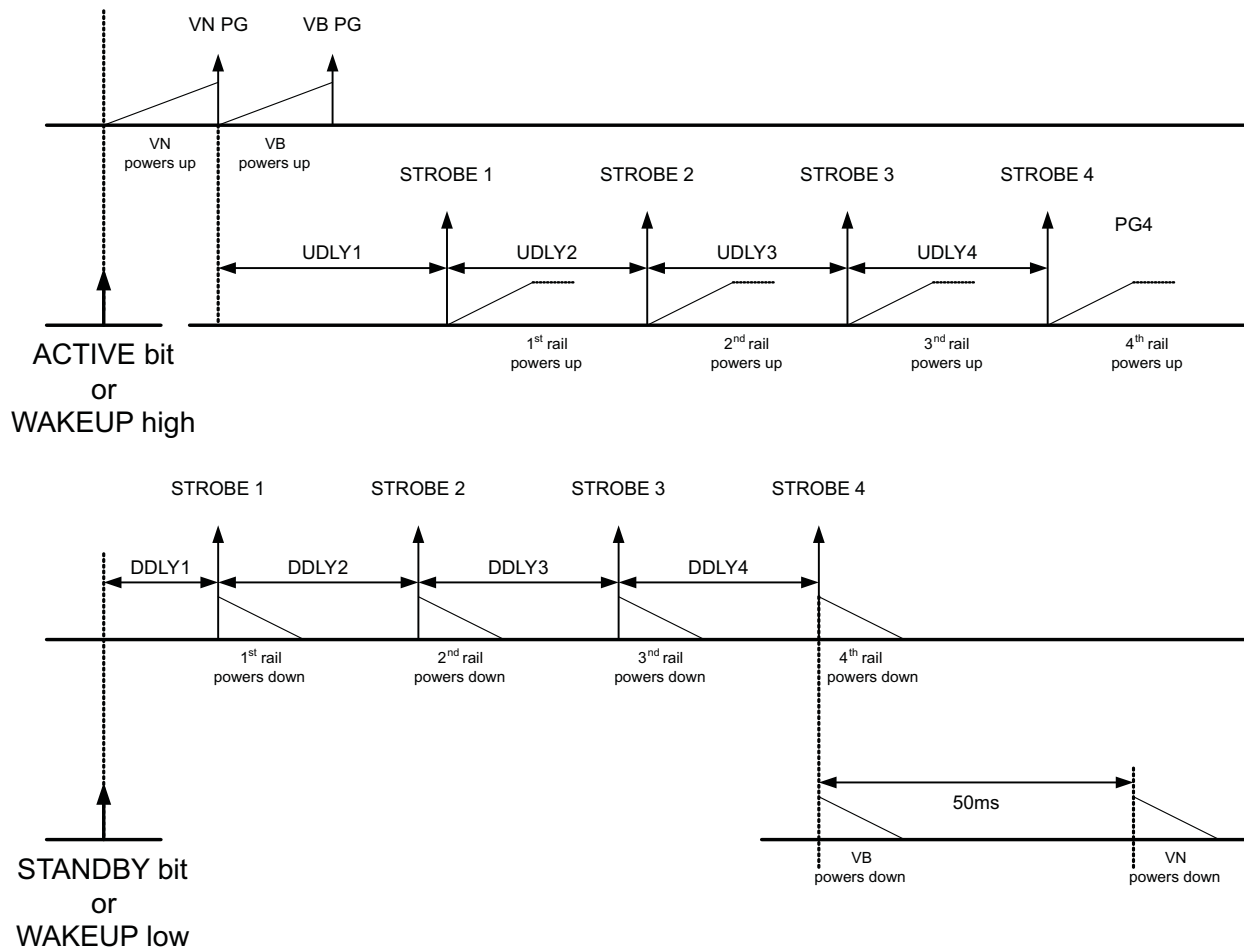
Feature Description (continued)

TOP: Power-up sequence is defined by assigning strobes to individual rails. STROBE1 is the first strobe to occur after ACTIVE bit is set and STROBE4 is the last event in the sequence. Strobes are assigned to rails in UPSEQ0 register and delays between STROBES are defined in UPSEQ1 register.

BOTTOM: Power-down sequence is independent of power-up sequence. Strobes and delay times for power down sequence are set in DWNSSEQ0 and DWNSSEQ1 register.

Figure 20. Power-Up and Power-Down Sequence

8.3.3 Soft Start

TPS65186 supports soft start for all rails, that is, inrush current is limited during startup of DCDC1, DCDC2, LDO1, LDO2, CP1, and CP2. If DCDC1 or DCDC2 are unable to reach power-good status within 50 ms, the corresponding UV flag is set in the interrupt registers, the interrupt pin is pulled low, and the device enters STANDBY mode. LDO1, LDO2, positive and negative charge pumps also have a 50-ms power-good time-out limit. If either rail is unable to power up within 50 ms after it has been enabled, the corresponding UV flag is set and the interrupt pin is pulled low. However, the device will remain in ACTIVE mode in this case.

8.3.4 VPOS/VNEG Supply Tracking

LDO1 (VPOS) and LDO2 (VNEG) track each other in a way that they are of opposite sign but same magnitude. The sum of VLDO1 and VLDO2 is guaranteed to be less than 50 mV.

Feature Description (continued)

8.3.5 V3P3 Power Switch

The integrated power switch is used to cut the 3.3-V supply to the EPD panel and is controlled through the V3P3_EN pin of the ENABLE register. In SLEEP mode the switch is automatically turned off and its output is discharged to ground. The default power-up state is OFF. To turn the switch ON, set the V3P3_ENbit to 1.

8.3.6 VCOM Adjustment

VCOM is the output of a power-amplifier with an output voltage range of 0 V to –5.11 V, adjustable in 10-mV steps. In a typical application VCOM is connected to the VCOM terminal of the EPD panel and the amplifier is controlled through the VCOM_CTRL pin. With VCOM_CTRL high, the amplifier drives the VCOM pin to the voltage specified by the VCOM1 and VCOM2 register.

For ease of design, the VCOM_CTRL pin may also be tied to the battery or IO supply. In this case, VCOM is enabled with STROBE4 during the power-up sequence and disabled on STROBE1 of the power-down sequence. Therefore VCOM is the last rail to be enabled and the first to be disabled.

8.3.6.1 Kick-Back Voltage Measurement

TPS65186 can perform a voltage measurement on the VCOM pin to determine the kick-back voltage of the panel. This allows in-system calibration of VCOM. To perform a kick-back voltage measurement, follow these steps:

- Pull the WAKEUP pin and the PWRUP pin high to enable all output rails.
- Set the Hi-Z bit in the VCOM2 register. This puts the VCOM pin in a high-impedance state.
- Drive the panel with the Null waveform. Refer to E-Ink specification for detail.
- Set the ACQ bit in the VCOM2 register to 1. This starts the measurement routine.
- When the measurement is complete, the ACQC (Acquisition Complete) bit in the INT1 register is set and the nINT pin is pulled low.
- The measurement result is stored in the VCOM[8:0] bits of the VCOM1 and VCOM2 register.

The measurement result is not automatically programmed into nonvolatile memory. Changing the power-up default is described in [Storing the VCOM Power-Up Default Value in Memory](#).

8.3.6.2 Storing the VCOM Power-Up Default Value in Memory

The power-up default value of VCOM can be user-set and programmed into nonvolatile memory. To do so, write the default value to the VCOM[8:0] bits of the VCOM1 and VCOM2 register, then set the PROG bit in VCOM2 register to 1. First, all power rails are shut down, then the VCOM[8:0] value is committed to nonvolatile memory such that it becomes the new power-up default. Once programming is complete, the PRGC bit in the INT1 register is set and the nINT pin is pulled low. To verify that the new value has been saved properly, first write the VCOM[8:0] bits to 0x00h, then pull the WAKEUP pin low. After the WAKEUP pin is pulled back high, read the VCOM[8:0] bits to verify that the new default value is correct.

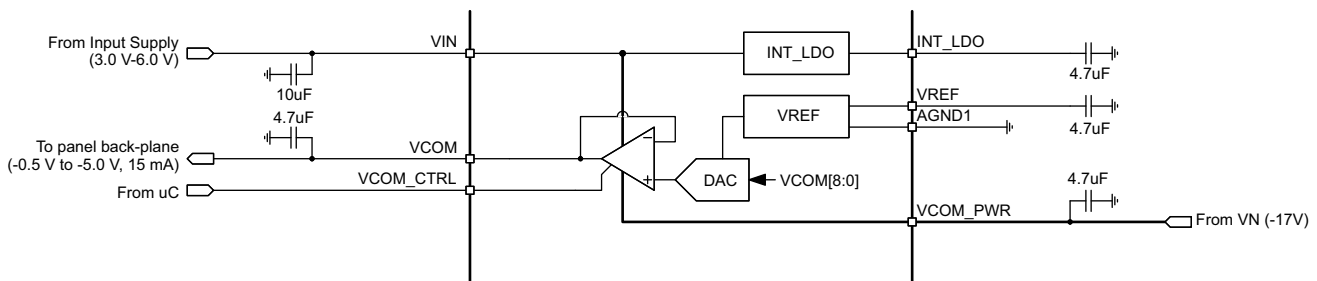

Figure 21. Block Diagram of VCOM Circuit

Feature Description (continued)

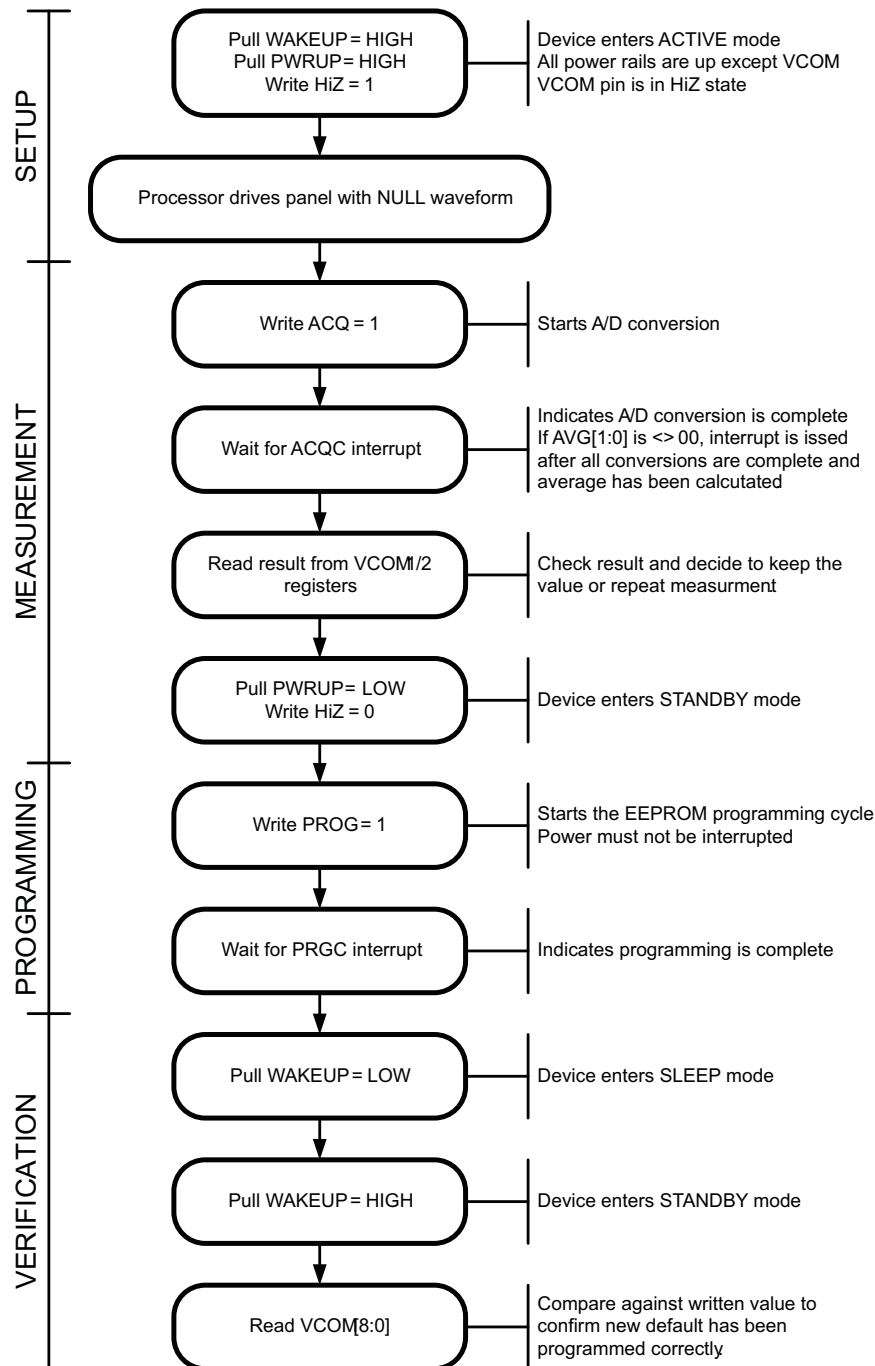

Figure 22. VCOM Calibration Flow

Feature Description (continued)

8.3.7 Fault Handling and Recovery

The TPS65186 monitors input/output voltages and die temperature; the device will take action if operating conditions are outside normal limits when the following are encountered:

- Thermal Shutdown (TSD)
- Positive Boost Undervoltage (VB_UV)
- Inverting Buck-Boost Undervoltage (VN_UV)
- Input Undervoltage Lockout (UVLO)

The TPS65186 shuts down all power rails and enters STANDBY mode. Shutdown follows the order defined by DWNSEQx registers. The exception is VCOM fault which leads to immediate shutdown of all rails. Once a fault is detected, the PWR_GOOD and nINT pins are pulled low and the corresponding interrupt bit is set in the interrupt register. Power rails cannot be re-enabled unless the interrupt bits have been cleared by reading the INT1 and INT2 register. Alternatively, toggling the WAKEUP pin also resets the interrupt bits. As the PWRUP input is edge sensitive, the host must toggle the PWRUP pin to re-enable the rails through GPIO control, that is, it must bring the PWRUP pin low before asserting it again. Alternatively rails can be re-enabled through the I²C interface.

Whenever the TPS65186 encounters undervoltage on VNEG (VNEG_UV), VPOS (VPOS_UV), VEE (VEE_UV), or VDDH (VDDH_UV), rails are not shut down but the PWR_GOOD and nINT is pulled low with the corresponding interrupt bit set. The device remains in ACTIVE mode and recovers automatically once the fault has been removed.

8.3.8 Power Good Pin

The power good pin (PWR_GOOD) is an open-drain output that is pulled high (by an external pullup resistor) when all four power rails (CP1, CP2, LDO1, LDO2) are in regulation and is pulled low if any of the rails encounters a fault or is disabled. PWR_GOOD remains low if one of the rails is not enabled by the host and only after all rails are in regulation PWR_GOOD is released to Hi-Z state (pulled up by external resistor).

8.3.9 Interrupt Pin

The interrupt pin (nINT) is an open-drain output that is pulled low whenever one or more of the INT1 or INT2 bits are set. The nINT pin is released (returns to Hi-Z state) and fault bits are cleared once the register with the set bit has been read by the host. If the fault persists, the nINT pin will be pulled low again after a maximum of 32 μ s.

Interrupt events can be masked by re-setting the corresponding enable bit in the INT_EN1 and INT_EN2 register, that is, the user can determine which events cause the nINT pin to be pulled low. The status of the enable bits affects the nINT pin only and has no effect on any of the protection and monitoring circuits or the INT1/INT2 bits themselves.

Persisting faults such as thermal shutdown can cause the nINT pin to be pulled low for an extended period of time which can keep the host in a loop trying to resolve the interrupt. If this behavior is not desired, set the corresponding mask bit after receiving the interrupt and keep polling the INT1/INT2 register to see when the fault condition has disappeared. After the fault is resolved, unmask the interrupt bit again.

8.3.10 Panel Temperature Monitoring

The TPS65186 provides circuitry to bias and measure an external Negative Temperature Coefficient Resistor (NTC) to monitor the display panel temperature in a range from -10°C to 85°C with an accuracy of $\pm 1^{\circ}\text{C}$ from 0°C to 50°C . Temperature measurement must be triggered by the controlling host and the last temperature reading is always stored in the TMST_VALUE register. Interrupts are issued when the temperature exceeds the programmable HOT, or drops below the programmable COLD threshold, or when the temperature has changed by more than a user-defined threshold from the baseline value. Details are explained under [Hot, Cold, and Temperature-Change Interrupts](#).

Feature Description (continued)

8.3.10.1 NTC Bias Circuit

Figure 23 shows the block diagram of the NTC bias and measurement circuit. The NTC is biased from an internally generated 2.25-V reference voltage through an integrated 7.307-k Ω bias resistor. A 43-k Ω resistor is connected parallel to the NTC to linearize the temperature response curve. The circuit is designed to work with a nominal 10-k Ω NTC and achieves accuracy of $\pm 1^{\circ}\text{C}$ from 0°C to 50°C . The voltage drop across the NTC is digitized by a 10-bit SAR ADC and translated into an 8-bit two's complement by digital per Table 1.

Table 1. ADC Output Value vs Temperature

TEMPERATURE	TMST_VALUE[7:0]
< -10°C	1111 0110
-10°C	1111 0110
-9°C	1111 0111
...	...
-2°C	1111 1110
-1°C	1111 1111
0°C	0000 0000
1°C	0000 0001
2°C	0000 0010
...	...
25°C	0001 1001
...	...
85°C	0101 0101
$> 85^{\circ}\text{C}$	0101 0101

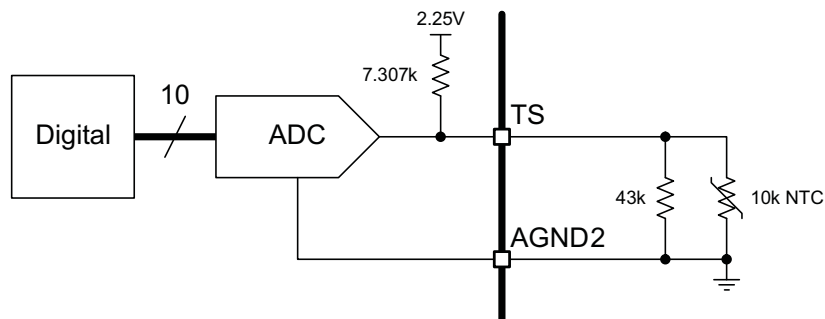

Figure 23. NTC Bias and Measurement Circuit

A temperature measurement is triggered by setting the READ_THERM bit of the TMST1 register to 1. During the A/D conversion the CONV_END bit of the TMST1 register reads 0, otherwise it reads 1. At the end of the A/D conversion the EOC bit in the INT2 register is set and the temperature value is available in the TMST_VALUE register.

8.3.10.2 Hot, Cold, and Temperature-Change Interrupts

Each temperature acquisition is compared against the programmable TMST_HOT and TMST_COLD thresholds and to the baseline temperature, to determine if the display is within allowed operating temperature range and if the temperature has changed by more than a user-defined threshold since the last update. The first temperature reading after the WAKEUP pin has been pulled high automatically becomes the baseline temperature. Any subsequent reading is compared against the baseline temperature. If the difference is equal or greater than the threshold value, an interrupt is issued (DTX bit in register INT1 is set to 1) and the latest value becomes the new baseline. If the difference is less than the threshold value, no action is taken. The threshold value is defined by DT[1:0] bits in the TMST1 register and has a default value of $\pm 2^{\circ}\text{C}$. In summary:

- When the temperature is equal or less than the TMST_COLD[3:0] threshold, the TMST_COLD interrupt bit of the INT1 register is set, and the nINT pin is pulled low.
- When the temperature is greater than TMST_COLD but lower than TMST_HOT, no action is taken.
- When the temperature is equal or greater than the TMST_HOT[3:0] threshold, the TMST_HOT interrupt bit of the INT1 register is set, and the nINT pin is pulled low.
- If the last temperature is different from the baseline temperature by $\pm 2^{\circ}\text{C}$ (default) or more, the DTX interrupt bit of the INT1 register is set. The latest temperature becomes the new baseline temperature. By default the DTX interrupt is disabled, that is, the nINT pin is not pulled low unless the DTX_EN bit was previously set high.
- If the last temperature change is less than $\pm 2^{\circ}\text{C}$ (default), no action is taken.

8.3.10.3 Typical Application of the Temperature Monitor

In a typical application the temperature monitor and interrupts are used in the following manner:

- After the WAKEUP pin has been pulled high, the Application Processor (AP) writes 0x80h to the TMST1 register (address 0x0Dh). This starts the temperature measurement.
- The AP waits for the EOC interrupt. Alternatively the AP can poll the CONV_END bit in register TMST1. This will notify the AP that the A/D conversion is complete and the new temperature reading is available in the TMST_VALUE register (address 0x00h).
- The AP reads the temperature value from the TMST_VALUE register (address 0x00h).
- If the temperature changes by $\pm 2^{\circ}\text{C}$ (default) or more from the first reading, the processor is notified by the DTX interrupt. The A/P may or may not decide to select a different set of waveforms to drive the panel.
- If the temperature is outside the allowed operating range of the panel, the processor is notified by the THOT and TCOLD interrupts, respectively. The processor may or may not decide to continue with the page update.
- When an overtemperature or undertemperature has been detected, the AP must reset the TMST_HOT_EN or TMST_COLD_EN bits, respectively, to avoid the nINT pin to be continuously pulled low. The TMST_HOT and TMST_COLD interrupt bits then must be polled continuously, to determine when the panel temperature recovers to the normal operating range. Once the temperature has recovered, the TMST_HOT_EN or TMST_COLD_EN bits must be set to 1 again and normal operation can resume.

8.4 Device Functional Modes

The TPS65186 has three modes of operation, SLEEP, STANDBY, and ACTIVE. SLEEP mode is the lowest-power mode in which all internal circuitry is turned off. In STANDBY, all power rails are shut down but the device is ready to accept commands through the I²C interface. In ACTIVE mode one or more power rails are enabled.

8.4.1 SLEEP

This is the lowest power mode of operation. All internal circuitry is turned off, registers are reset to default values and the device does not respond to I²C communications. TPS65186 enters SLEEP mode whenever WAKEUP pin is pulled low.

8.4.2 STANDBY

In STANDBY all internal support circuitry is powered up and the device is ready to accept commands through the I²C interface but none of the power rails are enabled. The device enters STANDBY mode when the WAKEUP pin is pulled high and either the PWRUP pin is pulled low or the STANDBY bit is set. The device also enters STANDBY mode if input undervoltage lockout (UVLO), positive boost undervoltage (VB_UV), or inverting buck-boost undervoltage (VN_UV) is detected, thermal shutdown occurs, or the PROG bit is set (see [Figure 22](#))

8.4.3 ACTIVE

The device is in ACTIVE mode when any of the output rails are enabled and no fault condition is present. This is the normal mode of operation while the device is powered up.

8.4.4 Mode Transitions

8.4.4.1 SLEEP → ACTIVE

WAKEUP pin is pulled high with PWRUP pin high. Rails come up in the order defined by the UPSEQx registers (OK to tie WAKEUP and PWRUP pin together).

8.4.4.2 SLEEP → STANDBY

WAKEUP pin is pulled high with PWRUP pin low. Rails will remain powered down.

8.4.4.3 STANDBY → ACTIVE

WAKEUP pin is high and PWRUP pin is pulled high (rising edge) or the ACTIVE bit is set. Output rails will power up in the order defined by the UPSEQx registers.

8.4.4.4 ACTIVE → STANDBY

WAKEUP pin is high and STANDBY bit is set or PWRUP pin is pulled low (falling edge). Rails are shut down in the order defined by DWNSEQx registers. Device also enters STANDBY in the event of thermal shutdown (TSD), undervoltage lockout (UVLO), positive boost or inverting buck-boost undervoltage (UV), VCOM fault (VCOMF), or when the PROG bit is set (see [Figure 22](#)).

8.4.4.5 STANDBY → SLEEP

WAKEUP pin is pulled low while none of the output rails are enabled.

8.4.4.6 ACTIVE → SLEEP

WAKEUP pin is pulled low while at least one output rail is enabled. Rails are shut down in the order defined by DWNSEQx registers.

Device Functional Modes (continued)

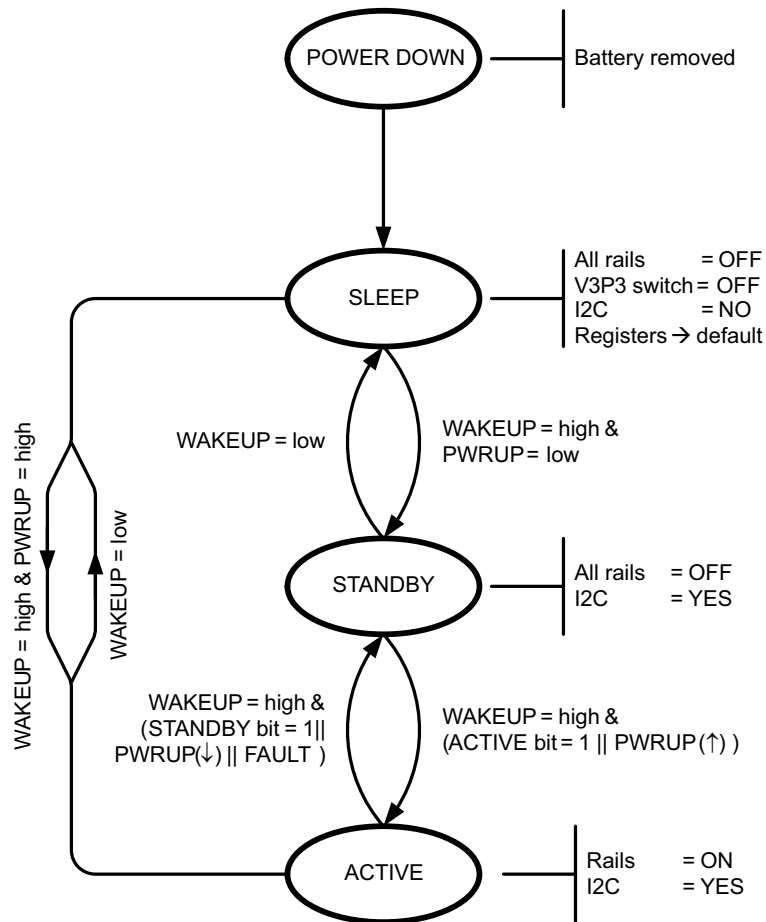

NOTES:
 ||, & = logic OR, and AND.
 (↑), (↓) = rising edge, falling edge
 UVLO = Undervoltage Lockout
 TSD = Thermal Shutdown
 UV = Undervoltage
 FAULT = UVLO || TSD || BOOST UV || VCOM fault

Figure 24. Global State Diagram

8.5 Programming

8.5.1 I²C Bus Operation

The TPS65186 hosts a slave I²C interface that supports data rates up to 400 kbit/s and auto-increment addressing and is compliant to I²C standard 3.0.

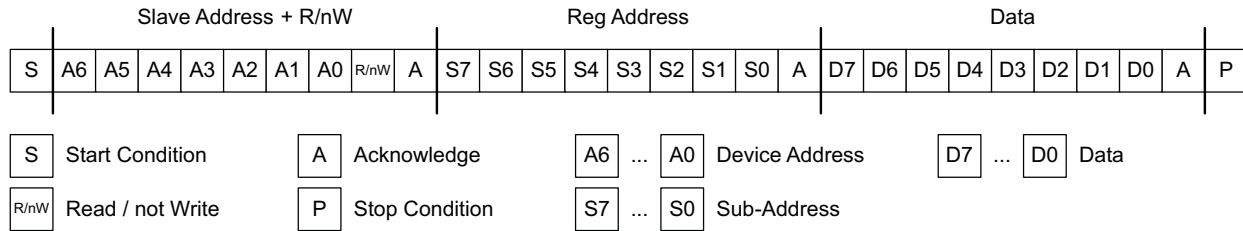
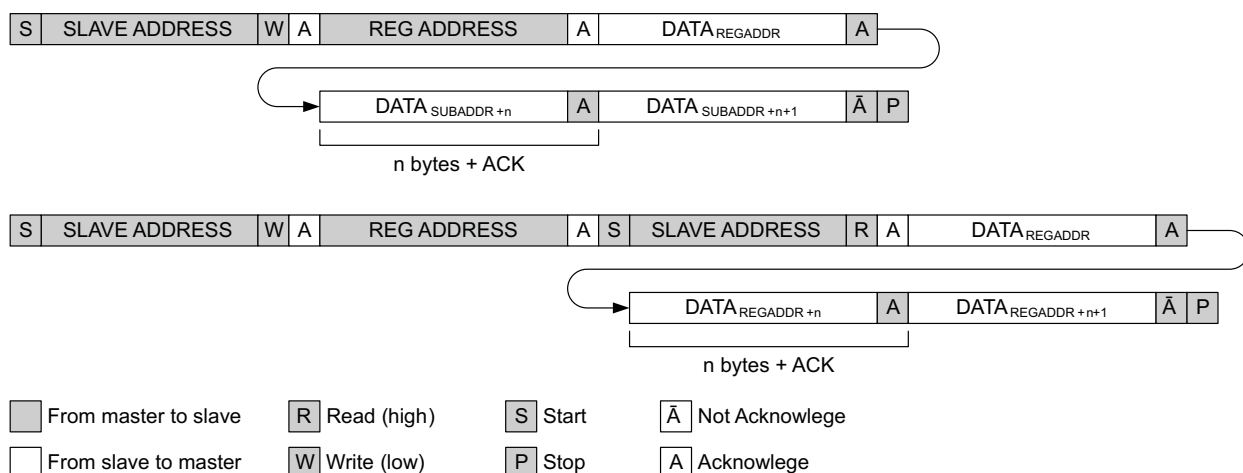

Figure 25. Subaddress in I²C Transmission

The I²C Bus is a communications link between a controller and a series of slave terminals. The link is established using a two-wire bus consisting of a serial clock signal (SCL) and a serial data signal (SDA). The serial clock is sourced from the controller in all cases where the serial data line is bidirectional for data communication between the controller and the slave terminals. Each device has an open drain output to transmit data on the serial data line. An external pullup resistor must be placed on the serial data line to pull the drain output high during data transmission.

Data transmission is initiated with a start bit from the controller as shown in Figure 27. The start condition is recognized when the SDA line transitions from high to low during the high portion of the SCL signal. Upon reception of a start bit, the device will receive serial data on the SDA input and check for valid address and control information. If the appropriate slave address bits are set for the device, then the device will issue an acknowledge pulse and prepare to receive the register address. Depending on the R/nW bit, the next byte received from the master is written to the addressed register (R/nW = 0) or the device responds with 8-bit data from the register (R/nW = 1). Data transmission is completed by either the reception of a stop condition or the reception of the data word sent to the device. A stop condition is recognized as a low to high transition of the SDA input during the high portion of the SCL signal. All other transitions of the SDA line must occur during the low portion of the SCL signal. An acknowledge is issued after the reception of valid address, sub-address and data words. The I²C interfaces will auto-sequence through register addresses, so that multiple data words can be sent for a given I²C transmission. See Figure 26 and Figure 27 for details.



TOP: Master writes data to slave.

BOTTOM: Master reads data from slave.

Figure 26. I²C Data Protocol

Programming (continued)

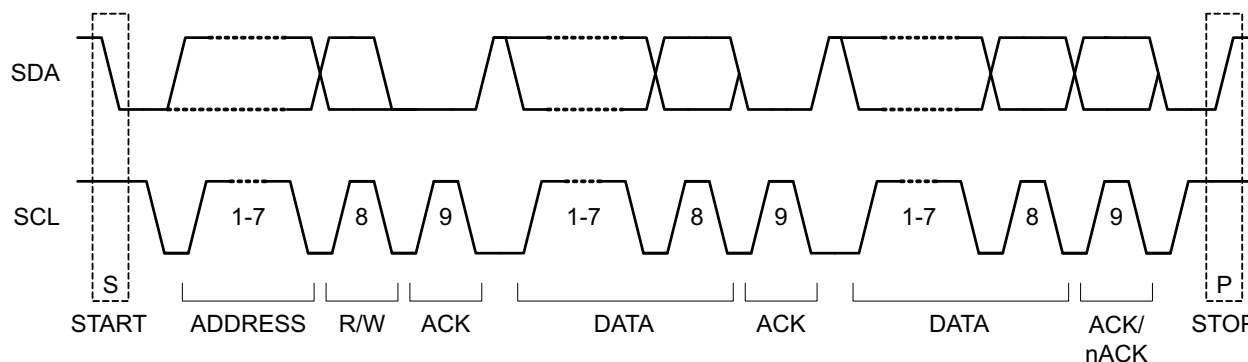

Figure 27. I²C Start/Stop/Acknowledge Protocol

8.6 Register Maps

REGISTER	ADDRESS (HEX)	NAME	DESCRIPTION
0	0x00	TMST_VALUE	Thermistor value read by ADC
1	0x01	ENABLE	Enable/disable bits for regulators
2	0x02	VADJ	VPOS/VNEG voltage adjustment
3	0x03	VCOM1	Voltage settings for VCOM
4	0x04	VCOM2	Voltage settings for VCOM + control
5	0x05	INT_EN1	Interrupt enable group1
6	0x06	INT_EN2	Interrupt enable group2
7	0x07	INT1	Interrupt group1
8	0x08	INT2	Interrupt group2
9	0x09	UPSEQ0	Power-up strobe assignment
10	0x0A	UPSEQ1	Power-up sequence delay times
11	0x0B	DWNSEQ0	Power-down strobe assignment
12	0x0C	DWNSEQ1	Power-down sequence delay times
13	0x0D	TMST1	Thermistor configuration
14	0x0E	TMST2	Thermistor hot temp set
15	0x0F	PG	Power good status each rails
16	0x10	REVID	Device revision ID information

8.6.1 Thermistor Readout (TMST_VALUE)

Address – 0x00h

DATA BIT	D7	D6	D5	D4	D3	D2	D1	D0
FIELD NAME	TMST_VALUE[7:0]							
READ/WRITE	R	R	R	R	R	R	R	R
RESET VALUE	N/A	N/A	N/A	N/A	N/A	N/A	N/A	N/A

FIELD NAME	BIT DEFINITION
TMST_VALUE[7:0]	Temperature read-out 1111 0110 – < -10°C 1111 0110 – -10°C 1111 0111 – -9°C ... 1111 1110 – -2°C 1111 1111 – -1 °C 0000 0000 – 0 °C 0000 0001 – 1°C 0000 0010 – 2°C ... 0001 1001 – 25°C ... 0101 0101 – 85°C 0101 0101 – > 85°C

8.6.2 Enable (ENABLE)

Address – 0x01h

DATA BIT	D7	D6	D5	D4	D3	D2	D1	D0
FIELD NAME	ACTIVE	STANDBY	V3P3_EN	VCOM_EN	VDDH_EN	VPOS_EN	VEE_EN	VNEG_EN
READ/WRITE	R/W	R/W	R/W	R/W	R/W	R/W	R/W	R/W
RESET VALUE	0	0	0	0	0	0	0	0

FIELD NAME	BIT DEFINITION ⁽¹⁾
ACTIVE	STANDBY to ACTIVE transition bit 1 – Transition from STANDBY to ACTIVE mode. Rails power up as defined by UPSEQx registers 0 – no effect NOTE: After transition bit is cleared automatically
STANDBY	STANDBY to ACTIVE transition bit 1 – Transition from STANDBY to ACTIVE mode. Rails power up as defined by DWNSEQx registers 0 – no effect NOTE: After transition bit is cleared automatically. STANDBY bit has priority over AVTIVE.
V3P3_EN	VIN3P3 to V3P3 switch enable 1 – switch is ON 0 – switch is OFF
VCOM_EN	VCOM buffer enable 1 – enabled 0 – disabled
VDDH_EN	VDDH charge pump enable 1 – enabled 0 – disabled
VPOS_EN	VPOS LDO regulator enable 1 – enabled 0 – disabled NOTE: VPOS cannot be enabled before VNEG is enabled.
VEE_EN	VEE charge pump enable 1 – enabled 0 – disabled
VNEG_EN	VNEG LDO regulator enable 1 – enabled 0 – disabled NOTE: When VNEG is disabled VPOS will also be disabled.

(1) Enable bits always reflect actual status of the corresponding rail.

8.6.3 Voltage Adjustment Register (VADJ)

Address – 0x02h

DATA BIT	D7	D6	D5	D4	D3	D2	D1	D0
FIELD NAME	not used	not used	not used	not used	not used	VSET[2:0]		
READ/WRITE	R/W	R/W	R/W	R/W	R	R/W	R/W	R/W
RESET VALUE	0	0	1	0	0	0 ^{E2}	1 ^{E2}	1 ^{E2}

FIELD NAME	BIT DEFINITION
not used	N/A
not used	N/A
not used	N/A
not used	N/A
not used	N/A
VSET[2:0]	VPOS and VNEG voltage setting 000 - not valid 001 - not valid 010 - not valid 011 - ±15.000 V 100 - ±14.750 V 101 - ±14.500 V 110 - ±14.250 V 111 - reserved

8.6.4 VCOM 1 (VCOM1)

Address – 0x03h

DATA BIT	D7	D6	D5	D4	D3	D2	D1	D0
FIELD NAME	VCOM [7:0]							
READ/WRITE	R/W	R/W	R/W	R/W	R/W	R/W	R/W	R/W
RESET VALUE	0 ^{E2}	1 ^{E2}	1 ^{E2}	1 ^{E2}	1	1	0	1

FIELD NAME	BIT DEFINITION
VCOM[7:0]	VCOM voltage, least significant byte. See VCOM 2 (VCOM2) for details.

8.6.5 VCOM 2 (VCOM2)

Address – 0x04h

DATA BIT	D7	D6	D5	D4	D3	D2	D1	D0
FIELD NAME	ACQ	PROG	HiZ	AVG[1:0]		not used	not used	VCOM[8]
READ/WRITE	R/W	R/W	R/W	R/W	R/W	R/W	R/W	R/W
RESET VALUE	0	0	0	0	0	1	0	0 ^{E2}

FIELD NAME	BIT DEFINITION
ACQ	Kick-back voltage acquisition bit 1 – starts kick-back voltage measurement routine 0 – no effect NOTE: After measurement is complete bit is cleared automatically and measurement result is reflected in VCOM[8:0] bits.
PROG	VCOM programming bit 1 – VCOM[8:0] value is committed to nonvolatile memory and becomes new power-up default 0 – no effect NOTE: After programming bit is cleared automatically and TPS65186 will enter STANDBY mode.
HiZ	VCOM HiZ bit 1 – VCOM pin is placed into hi-impedance state to allow VCOM measurement 0 – VCOM amplifier is connected to VCOM pin
AVG[1:0]	Number of acquisitions that is averaged to a single kick-back voltage measurement 00 – 1x 01 – 2x 10 – 4x 11 – 8x NOTE: When the ACQ bit is set, the state machine repeat the A/D conversion of the kick-back voltage AVD[1:0] times and returns a single, averaged, value to VCOM[8:0]
not used	N/A
not used	N/A
VCOM[8:0]	VCOM voltage adjustment $V_{COM} = V_{COM}[8:0] \times -10 \text{ mV}$ in the range from 0 mV to –5.110 V 0x000h – 0 0000 0000 – –0 mV 0x001h – 0 0000 0001 – –10 mV 0x002h – 0 0000 0010 – –20 mV ... 0x07Dh - 0 0111 1101 – –1250 mV ... 0x1FEh – 1 1111 1110 – –5100 mV 0x1FFh – 1 1111 1111 – –5110 mV

TPS65186

ZHCS462A – JULY 2011 – REVISED AUGUST 2015

www.ti.com.cn
8.6.6 Interrupt Enable 1 (INT_EN1)

Address – 0x05h

DATA BIT	D7	D6	D5	D4	D3	D2	D1	D0
FIELD NAME	DTX_EN	TSD_EN	HOT_EN	TMST_HOT_EN	TMST_COLD_EN	UVLO_EN	ACQC_EN	PRGC_EN
READ/WRITE	R	R/W	R/W	R/W	R/W	R/W	R	R
RESET VALUE	0	1	1	1	1	1	1	1

FIELD NAME	BIT DEFINITION ⁽¹⁾
DTX_EN	Panel temperature-change interrupt enable 1 – enabled 0 – disabled
TSD_EN	Thermal shutdown interrupt enable 1 – enabled 0 – disabled
HOT_EN	Thermal shutdown early warning enable 1 – enabled 0 – disabled
TMST_HOT_EN	Thermistor hot interrupt enable 1 – enabled 0 – disabled
TMST_COLD_EN	Thermistor cold interrupt enable 1 – enabled 0 – disabled
UVLO_EN	VIN undervoltage detect interrupt enable 1 – enabled 0 – disabled
ACQC_EN	VCOM acquisition complete interrupt enable 1 – enabled 0 – disabled
PRGC_EN	VCOM programming complete interrupt enable 1 – enabled 0 – disabled

- (1) Enabled means nINT pin is pulled low when interrupt occurs.
Disabled means nINT pin is not pulled low when interrupt occurs.

8.6.7 Interrupt Enable 2 (INT_EN2)

Address – 0x06h

DATA BIT	D7	D6	D5	D4	D3	D2	D1	D0
FIELD NAME	VBUVEN	VDDHUVEN	VNUV_EN	VPOSUVEN	VEEUVEN	VCOMFEN	VNEGUVEN	EOCEN
READ/WRITE	R/W	R/W	R/W	R/W	R/W	R/W	R/W	R/W
RESET VALUE	1	1	1	1	1	1	1	1

FIELD NAME	BIT DEFINITION ⁽¹⁾
VBUVEN	Positive boost converter undervoltage detect interrupt enable 1 – enabled 0 – disabled
VDDHUVEN	VDDH undervoltage detect interrupt enable 1 – enabled 0 – disabled
VNUVEN	Inverting buck-boost converter undervoltage detect interrupt enable 1 – enabled 0 – disabled
VPOSUVEN	VPOS undervoltage detect interrupt enable 1 – enabled 0 – disabled
VEEUVEN	VEE undervoltage detect interrupt enable 1 – enabled 0 – disabled
VCOMFEN	VCOM FAULT interrupt enable 1 – enabled 0 – disabled
VNEGUVEN	VNEG undervoltage detect interrupt enable 1 – enabled 0 – disabled
EOCEN	Temperature ADC end of conversion interrupt enable 1 – enabled 0 – disabled

- (1) Enabled means nINT pin is pulled low when interrupt occurs.
Disabled means nINT pin is not pulled low when interrupt occurs.

TPS65186

ZHCS462A – JULY 2011 – REVISED AUGUST 2015

www.ti.com.cn
8.6.8 Interrupt 1 (INT1)

Address – 0x07h

DATA BIT	D7	D6	D5	D4	D3	D2	D1	D0
FIELD NAME	DTX	TSD	HOT	TMST_HOT	TMST_COLD	UVLO	ACQC	PRGC
READ/WRITE	R	R	R	R	R	R	R	R
RESET VALUE	0	N/A	N/A	N/A	N/A	N/A	0	0

FIELD NAME	BIT DEFINITION
DTX	Panel temperature-change interrupt 1 – temperature has changed by 3 deg or more over previous reading 0 – no significance
TSD	Thermal shutdown interrupt 1 – chip is in overtemperature shutdown 0 – no fault
HOT	Thermal shutdown early warning 1 – chip is approaching overtemperature shutdown 0 – no fault
TMST_HOT	Thermistor hot interrupt 1 – thermistor temperature is equal or greater than TMST_HOT threshold 0 – no fault
TMST_COLD	Thermistor cold interrupt 1 – thermistor temperature is equal or less than TMST_COLD threshold 0 – no fault
UVLO	VIN undervoltage detect interrupt 1 – input voltage is below UVLO threshold 0 – no fault
ACQC	VCOM acquisition complete 1 – VCOM measurement is complete 0 – no significance
PRGC	VCOM programming complete 1 – VCOM programming is complete 0 – no significance

8.6.9 Interrupt 2 (INT2)

Address – 0x08h

DATA BIT	D7	D6	D5	D4	D3	D2	D1	D0
FIELD NAME	VB_UV	VDDH_UV	VN_UV	VPOS_UV	VEE_UV	VCOMF	VNEG_UV	EOC
READ/WRITE	R	R	R	R	R	R	R	R
RESET VALUE	N/A	N/A	N/A	N/A	N/A	N/A	N/A	N/A

FIELD NAME	BIT DEFINITION
VB_UV	Positive boost converter undervoltage detect interrupt 1 – under-voltage on DCDC1 detected 0 – no fault
VDDH_UV	VDDH undervoltage detect interrupt 1 – undervoltage on VDDH charge pump detected 0 – no fault
VN_UV	Inverting buck-boost converter undervoltage detect interrupt 1 – undervoltage on DCDC2 detected 0 – no fault
VPOS_UV	VPOS undervoltage detect interrupt 1 – undervoltage on LDO1(VPOS) detected 0 – no fault
VEE_UV	VEE undervoltage detect interrupt 1 – undervoltage on VEE charge pump detected 0 – no fault
VCOMF	VCOM fault detection 1 – fault on VCOM detected (VCOM is outside normal operating range) 0 – no fault
VNEG_UV	VNEG undervoltage detect interrupt 1 – undervoltage on LDO2(VNEG) detected 0 – no fault
EOC	ADC end of conversion interrupt 1 – ADC conversion is complete (temperature acquisition is complete) 0 – no significance

8.6.10 Power Up Sequence Register 0 (UPSEQ0)

Address – 0x09h

DATA BIT	D7	D6	D5	D4	D3	D2	D1	D0
FIELD NAME	VDDH_UP[1:0]		VPOS_UP[1:0]		VEE_UP[1:0]		VNEG_UP[1:0]	
READ/WRITE	R/W	R/W	R/W	R/W	R/W	R/W	R/W	R/W
RESET VALUE	1 ^{E2}	1 ^{E2}	1 ^{E2}	0 ^{E2}	0 ^{E2}	1 ^{E2}	0 ^{E2}	0 ^{E2}

FIELD NAME	BIT DEFINITION
VDDH_UP[1:0]	VDDH power-up order 00 – power up on STROBE1 01 – power up on STROBE2 10 – power up on STROBE3 11 – power up on STROBE4
VPOS_UP[1:0]	VPOS power-up order 00 – power up on STROBE1 01 – power up on STROBE2 10 – power up on STROBE3 11 – power up on STROBE4
VEE_UP[1:0]	VEE power-up order 00 – power up on STROBE1 01 – power up on STROBE2 10 – power up on STROBE3 11 – power up on STROBE4
VNEG_UP[1:0]	VNEG power-up order 00 – power up on STROBE1 01 – power up on STROBE2 10 – power up on STROBE3 11 – power up on STROBE4

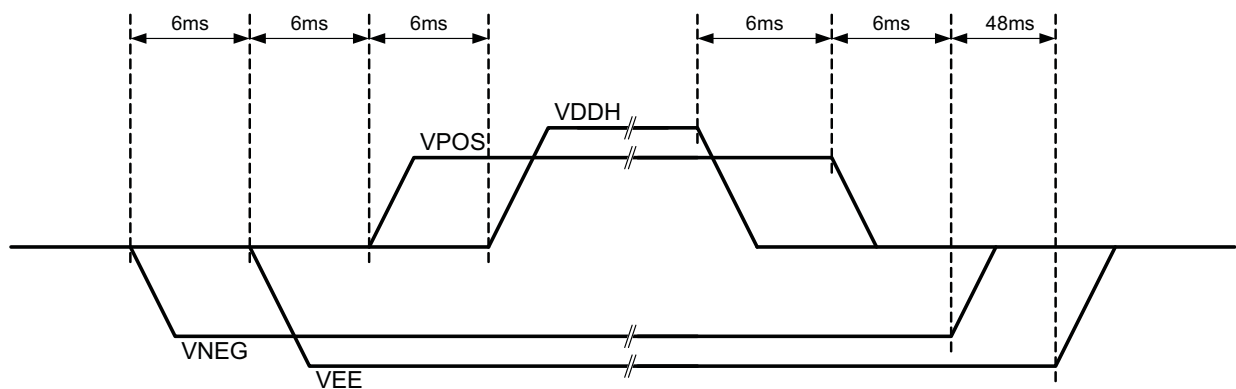
Figure 28. Default Power-Up/Power-Down Sequence

8.6.11 Power Up Sequence Register 1 (UPSEQ1)

Address – 0x0Ah

DATA BIT	D7	D6	D5	D4	D3	D2	D1	D0
FIELD NAME	UDLY4[1:0]		UDLY3[1:0]		UDLY2[1:0]		UDLY1[1:0]	
READ/WRITE	R/W	R/W	R/W	R/W	R/W	R/W	R/W	R/W
RESET VALUE	0 ^{E2}	1 ^{E2}	0 ^{E2}	1 ^{E2}	0 ^{E2}	1 ^{E2}	0 ^{E2}	1 ^{E2}

FIELD NAME	BIT DEFINITION
UDLY4[1:0]	DLY4 delay time set; defines the delay time from STROBE3 to STROBE4 during power up. 00 – 3 ms 01 – 6 ms 10 – 9 ms 11 – 12 ms
UDLY3[1:0]	DLY3 delay time set; defines the delay time from STROBE2 to STROBE3 during power up. 00 – 3 ms 01 – 6 ms 10 – 9 ms 11 – 12 ms
UDLY2[1:0]	DLY2 delay time set; defines the delay time from STROBE1 to STROBE2 during power up. 00 – 3 ms 01 – 6 ms 10 – 9 ms 11 – 12 ms
UDLY1[1:0]	DLY1 delay time set; defines the delay time from VN_PG high to STROBE1 during power up. 00 – 3 ms 01 – 6 ms 10 – 9 ms 11 – 12 ms

TPS65186

ZHCS462A – JULY 2011 – REVISED AUGUST 2015

www.ti.com.cn
8.6.12 Power Down Sequence Register 0 (DWNSEQ0)

Address – 0x0Bh

DATA BIT	D7	D6	D5	D4	D3	D2	D1	D0
FIELD NAME	VDDH_DWN[1:0]		VPOS_DWN[1:0]		VEE_DWN[1:0]		VNEG_DWN[1:0]	
READ/WRITE	R/W	R/W	R/W	R/W	R/W	R/W	R/W	R/W
RESET VALUE	0 ^{E2}	0 ^{E2}	0 ^{E2}	1 ^{E2}	1 ^{E2}	1 ^{E2}	1 ^{E2}	0 ^{E2}

FIELD NAME	BIT DEFINITION
VDDH_DWN[1:0]	VDDH power-down order 00 – power down on STROBE1 01 – power down on STROBE2 10 – power down on STROBE3 11 – power down on STROBE4
VPOS_DWN[1:0]	VPOS power-down order 00 – power down on STROBE1 01 – power down on STROBE2 10 – power down on STROBE3 11 – power down on STROBE4
VEE_DWN[1:0]	VEE power-down order 00 – power down on STROBE1 01 – power down on STROBE2 10 – power down on STROBE3 11 – power down on STROBE4
VNEG_DWN[1:0]	VNEG power-down order 00 – power down on STROBE1 01 – power down on STROBE2 10 – power down on STROBE3 11 – power down on STROBE4

8.6.13 Power Down Sequence Register 1 (DWNSEQ1)

Address – 0x0Ch

DATA BIT	D7	D6	D5	D4	D3	D2	D1	D0
FIELD NAME	DDLY4[1:0]		DDLY3[1:0]		DDLY2[1:0]		DDLY1	DFCTR
READ/WRITE	R/W	R/W	R/W	R/W	R/W	R/W	R/W	R/W
RESET VALUE	1 ^{E2}	1 ^{E2}	1 ^{E2}	0 ^{E2}	0 ^{E2}	0 ^{E2}	0 ^{E2}	0 ^{E2}

FIELD NAME	BIT DEFINITION
DDLY4[1:0]	DLY4 delay time set; defines the delay time from STROBE3 to STROBE4 during power down. 00 – 6 ms 01 – 12 ms 10 – 24 ms 11 – 48 ms
DDLY3[1:0]	DLY3 delay time set; defines the delay time from STROBE2 to STROBE3 during power down. 00 – 6 ms 01 – 12 ms 10 – 24 ms 11 – 48ms
DDLY2[1:0]	DLY2 delay time set; defines the delay time from STROBE1 to STROBE2 during power down. 00 – 6 ms 01 – 12 ms 10 – 24 ms 11 – 48 ms
DDLY1	DLY1 delay time set; defines the delay time from WAKEUP low to STROBE1 during power down. 0 – 3 ms 1 – 6 ms
DFCTR	At power-down delay time DLY2[1:0], DLY3[1:0], DLY4[1:0] are multiplied with DFCTR[1:0] 0 – 1x 1 – 16x

TPS65186

ZHCS462A – JULY 2011 – REVISED AUGUST 2015

www.ti.com.cn
8.6.14 Thermistor Register 1 (TMST1)

Address – 0x0Dh

DATA BIT	D7	D6	D5	D4	D3	D2	D1	D0
FIELD NAME	READ_THERM	not used	CONV_END	not used	not used	not used	DT[1:0]	
READ/WRITE	R/W	R/W	R	R/W	R/W	R/W	R/W	R/W
RESET VALUE	0	0	1	0	0	0	0	0

FIELD NAME	BIT DEFINITION
READ_THERM	Read thermistor value 1 – initiates temperature acquisition 0 – no effect NOTE: Bit is self-cleared after acquisition is completed
not used	N/A
CONV_END	ADC conversion done flag 1 – conversion is finished 0 – conversion is not finished
not used	N/A
not used	N/A
DT[1:0]	Panel temperature-change interrupt threshold 00 – 2°C 01 – 3°C 10 – 4°C 11 – 5°C DTX interrupt is issued when difference between most recent temperature reading and baseline temperature is equal to or greater than threshold value. See Hot, Cold, and Temperature-Change Interrupts for details.

8.6.15 Thermistor Register 2 (TMST2)

Address – 0x0Eh

DATA BIT	D7	D6	D5	D4	D3	D2	D1	D0
FIELD NAME	TMST_COLD[3:0]				TMST_HOT[3:0]			
READ/WRITE	R/W	R/W	R/W	R/W	R/W	R/W	R/W	R/W
RESET VALUE	0	1	1	1	1	0	0	0

FIELD NAME	BIT DEFINITION
TMST_COLD [3:0]	Thermistor COLD threshold 0000 – -7°C 0001 – -6°C 0010 – -5°C 0011 – -4°C 0100 – -3°C 0101 – -2°C 0110 – -1°C 0111 – 0°C 1000 – 1°C 1001 – 2°C 1010 – 3°C 1011 – 4°C 1100 – 5°C 1101 – 6°C 1110 – 7°C 1111 – 8°C NOTE: An interrupt is issued when thermistor temperature is equal or less than COLD threshold
TMST_HOT [3:0]	Thermistor HOT threshold 0000 – 42°C 0001 – 43°C 0010 – 44°C 0011 – 45°C 0100 – 46°C 0101 – 47°C 0110 – 48°C 0111 – 49°C 1000 – 50°C 1001 – 51°C 1010 – 52°C 1011 – 53°C 1100 – 54°C 1101 – 55°C 1110 – 56°C 1111 – 57°C NOTE: An interrupt is issued when thermistor temperature is equal or greater than HOT threshold

TPS65186

ZHCS462A –JULY 2011–REVISED AUGUST 2015

www.ti.com.cn
8.6.16 Power Good Status (PG)

Address – 0x0Fh

DATA BIT	D7	D6	D5	D4	D3	D2	D1	D0
FIELD NAME	VB_PG	VDDH_PG	VN_PG	VPOS_PG	VEE_PG	not used	VNEG_PG	not used
READ/WRITE	R	R	R	R	R	R	R	R
RESET VALUE	0	0	0	0	0	0	0	0

FIELD NAME	BIT DEFINITION ⁽¹⁾
VB_PG	Positive boost converter power good 1 – DCDC1 is in regulation 0 – DCDC1 is not in regulation or turned off
VDDH_PG	VDDH power good 1 – VDDH charge pump is in regulation 0 – VDDH charge pump is not in regulation or turned off
VN_PG	Inverting buck-boost power good 1 – DCDC2 is in regulation 0 – DCDC2 is not in regulation or turned off
VPOS_PG	VPOS power good 1 – LDO1(VPOS) is in regulation 0 – LDO1(VPOS) is not in regulation or turned off
VEE_PG	VEE power good 1 – VEE charge pump is in regulation 0 – VEE charge pump is not in regulation or turned off
not used	N/A
VNEG_PG	VNEG power good 1 – LDO2(VNEG) is in regulation 0 – LDO2(VNEG) is not in regulation or turned off
not used	N/A

(1) PG pin is pulled hi (Hi-Z state) when VDDH_PG = VPOS_PG = VEE_PG = VNEG_PG = 1

8.6.17 Revision and Version Control (REVID)

Address – 0x10h

DATA BIT	D7	D6	D5	D4	D3	D2	D1	D0
FIELD NAME	REVID[7:0]							
READ/WRITE	R	R	R	R	R	R	R	R
RESET VALUE	0	1	0	0	0 ^{E2}	1 ^{E2}	0 ^{E2}	1 ^{E2}

FIELD NAME	BIT DEFINITION
REVID[7:6]	MJREV
REVID[5:4]	MNREV
REVID[3:0]	VERSION
REVID [7:0]	0100 0101 - TPS65186 1p0 0101 0101 – TPS65186 1p1 0110 0101 – TPS65186 1p2

9 Application and Implementation

NOTE

Information in the following applications sections is not part of the TI component specification, and TI does not warrant its accuracy or completeness. TI's customers are responsible for determining suitability of components for their purposes. Customers should validate and test their design implementation to confirm system functionality.

9.1 Application Information

The TPS65186 is used to power display screens in E-book applications, specifically E-Ink Vizplex display, by connecting the screen to the positive and negative charge pump, LDOs 1 and 2, and VCOM rails. The display screens size that can be supported up to 9.7 inches.

9.2 Typical Application

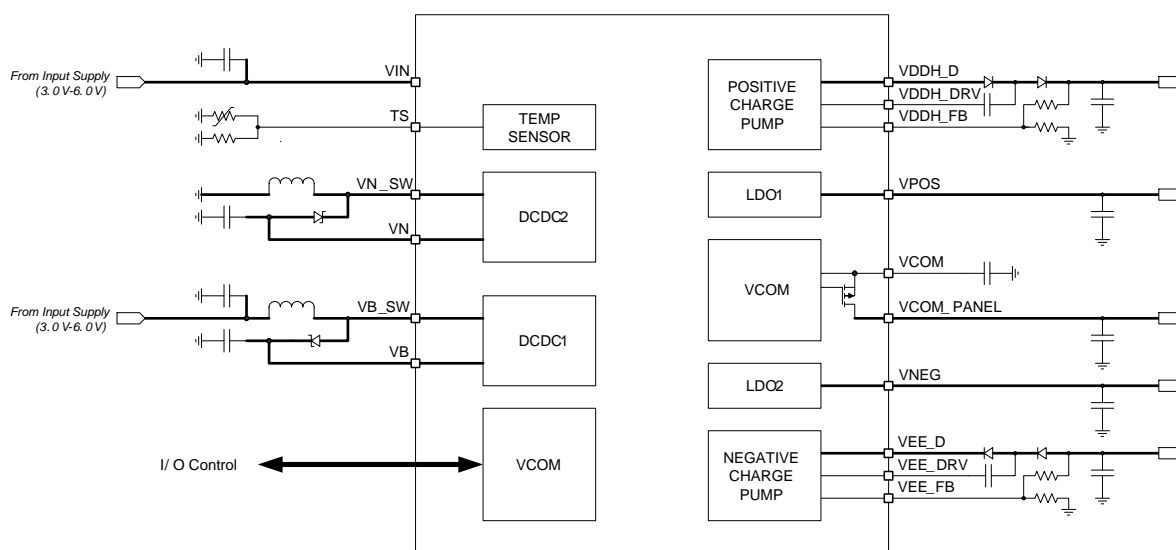

9.2.1 Design Requirements

For this design example, use the parameters listed in [Table 2](#) as the input parameters.

Table 2. Design Parameters

	VOLTAGE	SEQUENCE (STROBE)
VNEG (LDO2)	-15 V	1
VEE (Charge pump 2)	-20 V	2
VPOS (LDO1)	15 V	3
VDDH (Charge pump 1)	22 V	4

9.2.2 Detailed Design Procedure

Table 3. Recommended External Components

PART NUMBER	VALUE	SIZE	MANUFACTURER
INDUCTORS			
LQH44PN4R7MP0	4.7 μ H	4 mm \times 4 mm \times 1.65 mm	Murata
NR4018T4R7M	4.7 μ H	4 mm \times 4 mm \times 1.8 mm	Taiyo Yuden
VLS252015ET-2R2M	2.2 μ H	2 mm \times 2.5 mm \times 1.5 mm	TDK
NR4012T2R2M	2.2 μ H	4 mm \times 4 mm \times 1.2 mm	Taiyo Yuden
CAPACITORS			
GRM21BC81E475KA12L	4.7 μ F, 25 V, X6S	805	Murata
GRM32ER71H475KA88L	4.7 μ F, 50 V, X7R	1210	Murata
All other capacitors	X5R or better	—	—
DIODES			
BAS3010	—	SOD-323	Infineon
MBR130T1	—	SOD-123	ON-Semi
BAV99	—	SOT-23	Fairchild
THERMISTOR			
NCP18XH103F03RB	10 k Ω	603	Murata

9.2.3 Application Curves

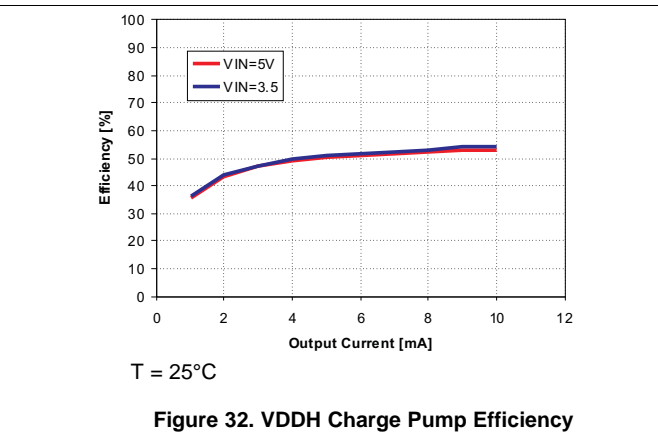
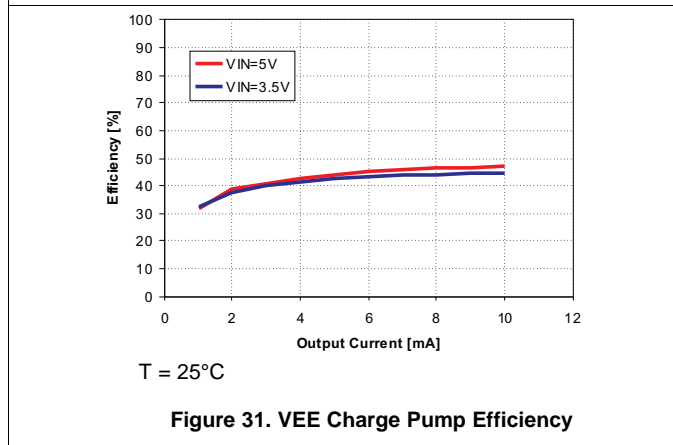
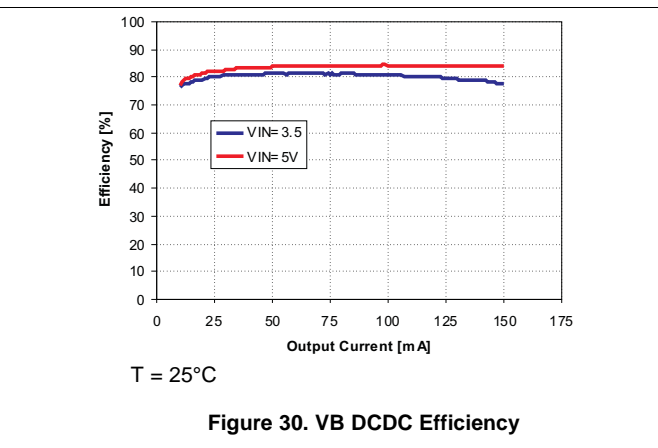
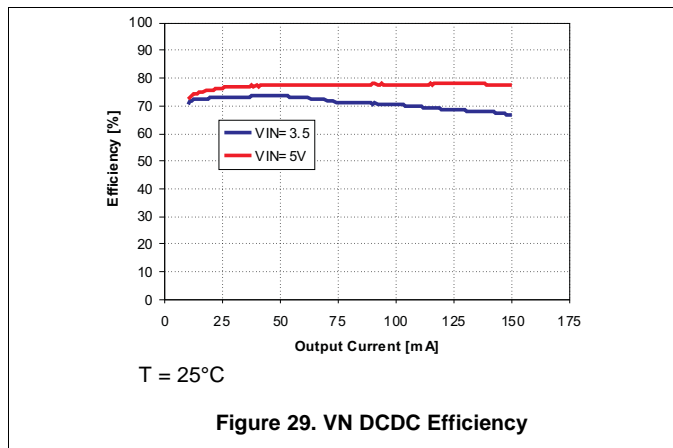

10 Power Supply Recommendations

The device is designed to operate with an input voltage supply range from 3 V to 6 V. This input supply can be from an externally regulated supply. If the input supply is located more than a few inches from the TPS65186, additional bulk capacitance may be required in addition to the ceramic bypass capacitors. An electrolytic capacitor with a value of 10 μF is a typical choice.

11 Layout

11.1 Layout Guidelines

1. PBKG (Die substrate) must connect to VN (-16 V) with short, wide trace. Wide copper trace will improve heat dissipation.
2. PowerPad is internally connected to PBKG and must not be connected to ground, but connected to VN with a short wide copper trace.
3. Inductor traces must be kept on the PCB top layer free of any vias.
4. Feedback traces must be routed away from any potential noise source to avoid coupling.
5. Output caps must be placed immediately at output pin.
6. Vin pins must be bypassed to ground with low ESR ceramic bypass capacitors.

11.2 Layout Example

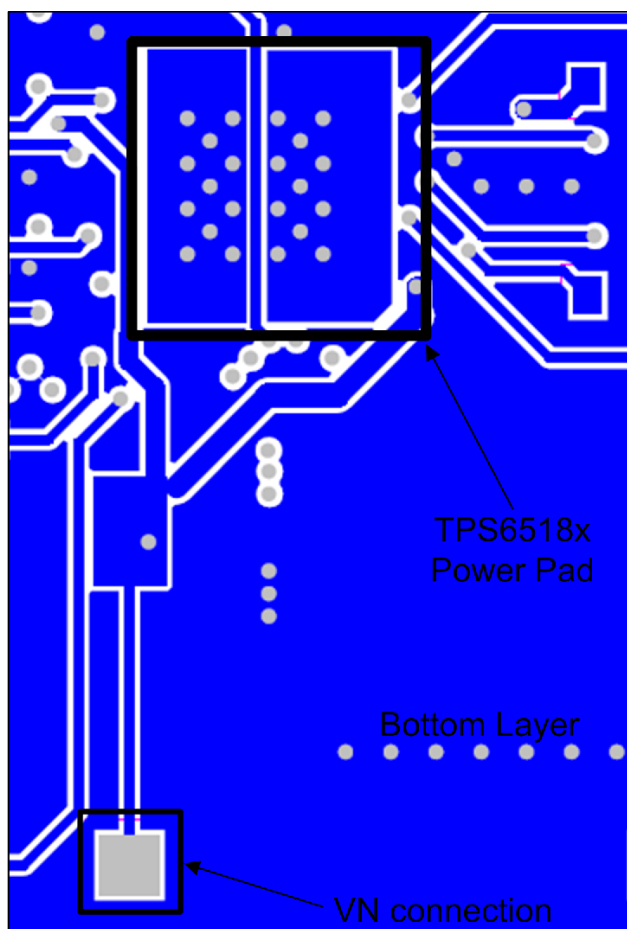

Figure 33. Layout Diagram

12 器件和文档支持

12.1 器件支持

12.1.1 Third-Party Products Disclaimer

TI'S PUBLICATION OF INFORMATION REGARDING THIRD-PARTY PRODUCTS OR SERVICES DOES NOT CONSTITUTE AN ENDORSEMENT REGARDING THE SUITABILITY OF SUCH PRODUCTS OR SERVICES OR A WARRANTY, REPRESENTATION OR ENDORSEMENT OF SUCH PRODUCTS OR SERVICES, EITHER ALONE OR IN COMBINATION WITH ANY TI PRODUCT OR SERVICE.

12.2 社区资源

The following links connect to TI community resources. Linked contents are provided "AS IS" by the respective contributors. They do not constitute TI specifications and do not necessarily reflect TI's views; see TI's [Terms of Use](#).

TI E2E™ Online Community *TI's Engineer-to-Engineer (E2E) Community*. Created to foster collaboration among engineers. At [e2e.ti.com](#), you can ask questions, share knowledge, explore ideas and help solve problems with fellow engineers.

Design Support *TI's Design Support* Quickly find helpful E2E forums along with design support tools and contact information for technical support.

12.3 商标

OMAP, E2E are trademarks of Texas Instruments.

Vizplex is a trademark of E Ink Corporation.

E Ink is a registered trademark of E Ink Corporation.

EPSON is a registered trademark of Seiko Epson Corporation.

12.4 静电放电警告



这些装置包含有限的内置 ESD 保护。存储或装卸时，应将导线一起截短或将装置放置于导电泡棉中，以防止 MOS 门极遭受静电损伤。

12.5 Glossary

SLYZ022 — *TI Glossary*.

This glossary lists and explains terms, acronyms, and definitions.

13 机械、封装和可订购信息

以下页中包括机械、封装和可订购信息。这些信息是针对指定器件可提供的最新数据。这些数据会在无通知且不对本文档进行修订的情况下发生改变。欲获得该数据表的浏览器版本，请查阅左侧的导航栏。

重要声明

德州仪器(TI)及其下属子公司有权根据 JESD46 最新标准,对所提供的产品和服务进行更正、修改、增强、改进或其它更改,并有权根据 JESD48 最新标准中止提供任何产品和服务。客户在下订单前应获取最新的相关信息,并验证这些信息是否完整且是最新的。所有产品的销售都遵循在订单确认时所提供的TI 销售条款与条件。

TI 保证其所销售的组件的性能符合产品销售时 TI 半导体产品销售条件与条款的适用规范。仅在 TI 保证的范围内,且 TI 认为有必要时才会使用测试或其它质量控制技术。除非适用法律做出了硬性规定,否则没有必要对每种组件的所有参数进行测试。

TI 对应用帮助或客户产品设计不承担任何义务。客户应对其使用 TI 组件的产品和应用自行负责。为尽量减小与客户产品和应用相关的风险,客户应提供充分的设计与操作安全措施。

TI 不对任何 TI 专利权、版权、屏蔽作品权或其它与使用了 TI 组件或服务的组合设备、机器或流程相关的 TI 知识产权中授予的直接或隐含权限作出任何保证或解释。TI 所发布的与第三方产品或服务有关的信息,不能构成从 TI 获得使用这些产品或服务的许可、授权、或认可。使用此类信息可能需要获得第三方的专利权或其它知识产权方面的许可,或是 TI 的专利权或其它知识产权方面的许可。

对于 TI 的产品手册或数据表中 TI 信息的重要部分,仅在没有对内容进行任何篡改且带有相关授权、条件、限制和声明的情况下才允许进行复制。TI 对此类篡改过的文件不承担任何责任或义务。复制第三方的信息可能需要服从额外的限制条件。

在转售 TI 组件或服务时,如果对该组件或服务参数的陈述与 TI 标明的参数相比存在差异或虚假成分,则会失去相关 TI 组件或服务的所有明示或暗示授权,且这是不正当的、欺诈性商业行为。TI 对任何此类虚假陈述均不承担任何责任或义务。

客户认可并同意,尽管任何应用相关信息或支持仍可能由 TI 提供,但他们将独立负责满足与其产品及其在应用中使用的 TI 产品相关的所有法律、法规和安全相关要求。客户声明并同意,他们具备制定与实施安全措施所需的全部专业技术和知识,可预见故障的危险后果、监测故障及其后果、降低有可能造成人身伤害的故障的发生机率并采取适当的补救措施。客户将全额赔偿因在此类安全关键应用中使用任何 TI 组件而对 TI 及其代理造成的任何损失。

在某些场合中,为了推进安全相关应用有可能对 TI 组件进行特别的促销。TI 的目标是利用此类组件帮助客户设计和创立其特有的可满足适用的功能安全性标准和要求的终端产品解决方案。尽管如此,此类组件仍然服从这些条款。

TI 组件未获得用于 FDA Class III (或类似的生命攸关医疗设备)的授权许可,除非各方授权官员已经达成了专门管控此类使用的特别协议。

只有那些 TI 特别注明属于军用等级或“增强型塑料”的 TI 组件才是设计或专门用于军事/航空应用或环境的。购买者认可并同意,对并非指定面向军事或航空航天用途的 TI 组件进行军事或航空航天方面的应用,其风险由客户单独承担,并且由客户独立负责满足与此类使用相关的所有法律和法规要求。

TI 已明确指定符合 ISO/TS16949 要求的产品,这些产品主要用于汽车。在任何情况下,因使用非指定产品而无法达到 ISO/TS16949 要求, TI 不承担任何责任。

	产品		应用
数字音频	www.ti.com.cn/audio	通信与电信	www.ti.com.cn/telecom
放大器和线性器件	www.ti.com.cn/amplifiers	计算机及周边	www.ti.com.cn/computer
数据转换器	www.ti.com.cn/dataconverters	消费电子	www.ti.com.cn/consumer-apps
DLP® 产品	www.dlp.com	能源	www.ti.com.cn/energy
DSP - 数字信号处理器	www.ti.com.cn/dsp	工业应用	www.ti.com.cn/industrial
时钟和计时器	www.ti.com.cn/clockandtimers	医疗电子	www.ti.com.cn/medical
接口	www.ti.com.cn/interface	安防应用	www.ti.com.cn/security
逻辑	www.ti.com.cn/logic	汽车电子	www.ti.com.cn/automotive
电源管理	www.ti.com.cn/power	视频和影像	www.ti.com.cn/video
微控制器 (MCU)	www.ti.com.cn/microcontrollers		
RFID 系统	www.ti.com.cn/rfidsys		
OMAP应用处理器	www.ti.com/omap		
无线连通性	www.ti.com.cn/wirelessconnectivity	德州仪器在线技术支持社区	www.deyisupport.com

邮寄地址: 上海市浦东新区世纪大道1568号, 中建大厦32楼邮政编码: 200122
Copyright © 2016, 德州仪器半导体技术(上海)有限公司

PACKAGING INFORMATION

Orderable Device	Status (1)	Package Type	Package Drawing	Pins	Package Qty	Eco Plan (2)	Lead finish/ Ball material (6)	MSL Peak Temp (3)	Op Temp (°C)	Device Marking (4/5)	Samples
TPS65186RGZR	ACTIVE	VQFN	RGZ	48	2500	RoHS & Green	NIPDAU	Level-3-260C-168 HR	-40 to 85	TPS65186	Samples
TPS65186RGZT	ACTIVE	VQFN	RGZ	48	250	RoHS & Green	NIPDAU	Level-3-260C-168 HR	-40 to 85	TPS65186	Samples

(1) The marketing status values are defined as follows:

ACTIVE: Product device recommended for new designs.

LIFEBUY: TI has announced that the device will be discontinued, and a lifetime-buy period is in effect.

NRND: Not recommended for new designs. Device is in production to support existing customers, but TI does not recommend using this part in a new design.

PREVIEW: Device has been announced but is not in production. Samples may or may not be available.

OBSOLETE: TI has discontinued the production of the device.

(2) **RoHS:** TI defines "RoHS" to mean semiconductor products that are compliant with the current EU RoHS requirements for all 10 RoHS substances, including the requirement that RoHS substance do not exceed 0.1% by weight in homogeneous materials. Where designed to be soldered at high temperatures, "RoHS" products are suitable for use in specified lead-free processes. TI may reference these types of products as "Pb-Free".

RoHS Exempt: TI defines "RoHS Exempt" to mean products that contain lead but are compliant with EU RoHS pursuant to a specific EU RoHS exemption.

Green: TI defines "Green" to mean the content of Chlorine (Cl) and Bromine (Br) based flame retardants meet JS709B low halogen requirements of <=1000ppm threshold. Antimony trioxide based flame retardants must also meet the <=1000ppm threshold requirement.

(3) MSL, Peak Temp. - The Moisture Sensitivity Level rating according to the JEDEC industry standard classifications, and peak solder temperature.

(4) There may be additional marking, which relates to the logo, the lot trace code information, or the environmental category on the device.

(5) Multiple Device Markings will be inside parentheses. Only one Device Marking contained in parentheses and separated by a "~" will appear on a device. If a line is indented then it is a continuation of the previous line and the two combined represent the entire Device Marking for that device.

(6) Lead finish/Ball material - Orderable Devices may have multiple material finish options. Finish options are separated by a vertical ruled line. Lead finish/Ball material values may wrap to two lines if the finish value exceeds the maximum column width.

Important Information and Disclaimer:The information provided on this page represents TI's knowledge and belief as of the date that it is provided. TI bases its knowledge and belief on information provided by third parties, and makes no representation or warranty as to the accuracy of such information. Efforts are underway to better integrate information from third parties. TI has taken and continues to take reasonable steps to provide representative and accurate information but may not have conducted destructive testing or chemical analysis on incoming materials and chemicals. TI and TI suppliers consider certain information to be proprietary, and thus CAS numbers and other limited information may not be available for release.

In no event shall TI's liability arising out of such information exceed the total purchase price of the TI part(s) at issue in this document sold by TI to Customer on an annual basis.

TAPE AND REEL INFORMATION

QUADRANT ASSIGNMENTS FOR PIN 1 ORIENTATION IN TAPE

*All dimensions are nominal

Device	Package Type	Package Drawing	Pins	SPQ	Reel Diameter (mm)	Reel Width W1 (mm)	A0 (mm)	B0 (mm)	K0 (mm)	P1 (mm)	W (mm)	Pin1 Quadrant
TPS65186RGZR	VQFN	RGZ	48	2500	330.0	16.4	7.3	7.3	1.1	12.0	16.0	Q2
TPS65186RGZT	VQFN	RGZ	48	250	180.0	16.4	7.3	7.3	1.1	12.0	16.0	Q2

TAPE AND REEL BOX DIMENSIONS

*All dimensions are nominal

Device	Package Type	Package Drawing	Pins	SPQ	Length (mm)	Width (mm)	Height (mm)
TPS65186RGZR	VQFN	RGZ	48	2500	367.0	367.0	38.0
TPS65186RGZT	VQFN	RGZ	48	250	210.0	185.0	35.0

GENERIC PACKAGE VIEW

RGZ 48

VQFN - 1 mm max height

7 x 7, 0.5 mm pitch

PLASTIC QUADFLAT PACK- NO LEAD

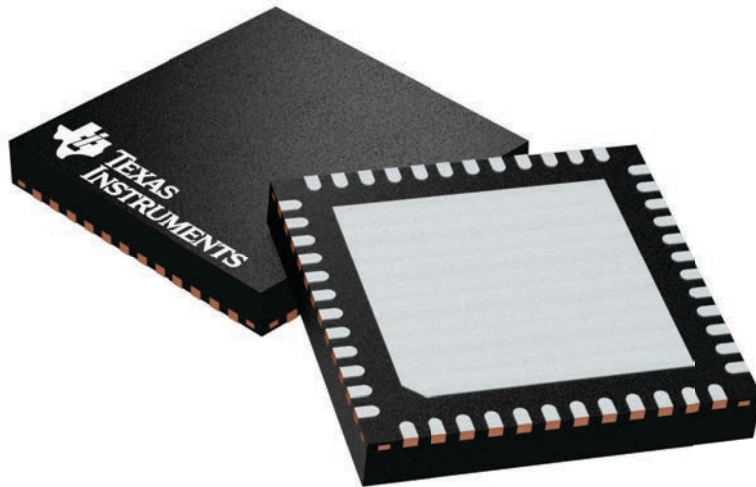

Images above are just a representation of the package family, actual package may vary.
Refer to the product data sheet for package details.

4224671/A

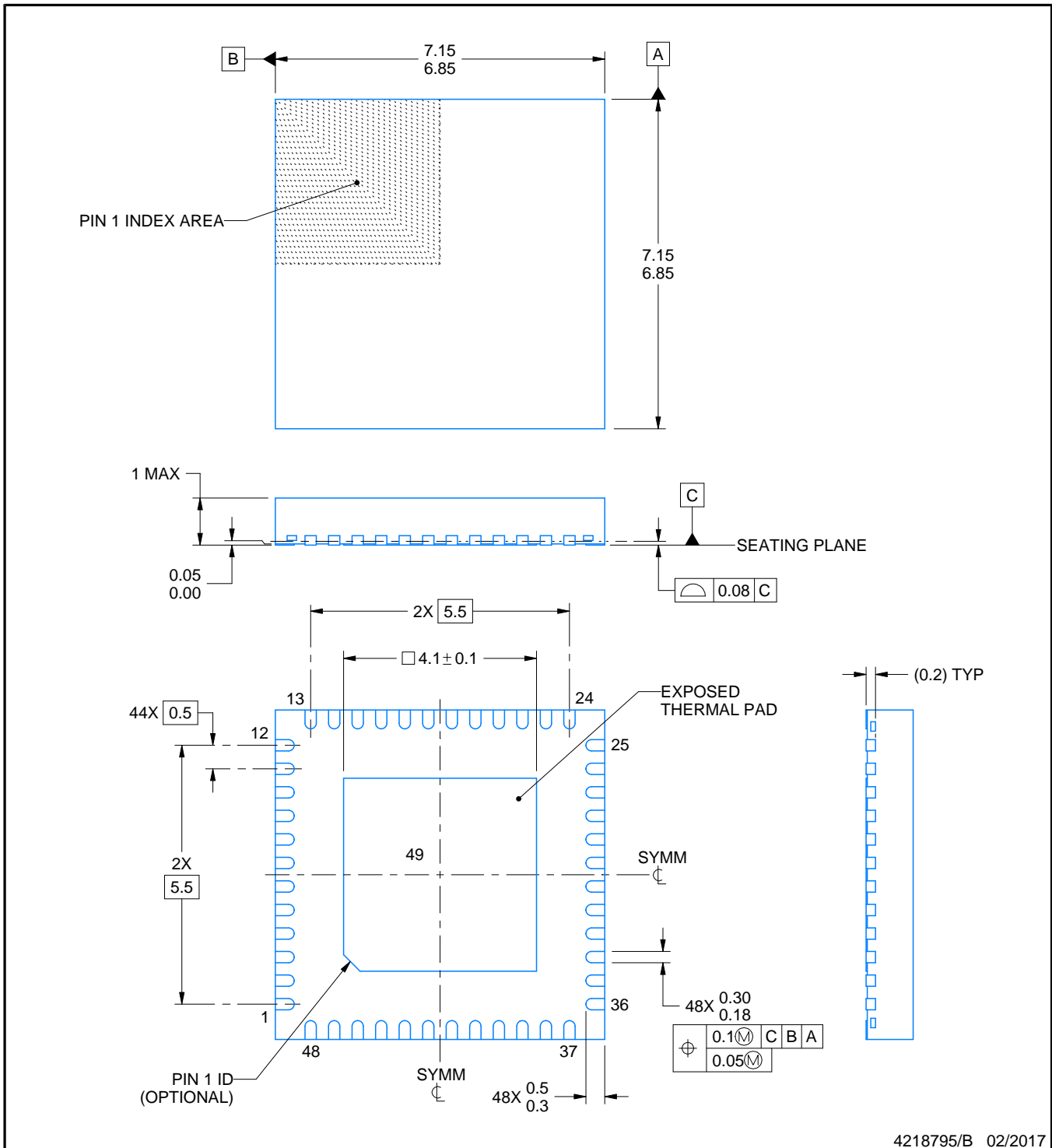
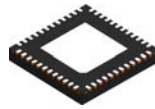

4218795/B 02/2017

NOTES:

1. All linear dimensions are in millimeters. Any dimensions in parenthesis are for reference only. Dimensioning and tolerancing per ASME Y14.5M.
2. This drawing is subject to change without notice.
3. The package thermal pad must be soldered to the printed circuit board for thermal and mechanical performance.

EXAMPLE BOARD LAYOUT

RGZ0048B

VQFN - 1 mm max height

PLASTIC QUAD FLATPACK - NO LEAD

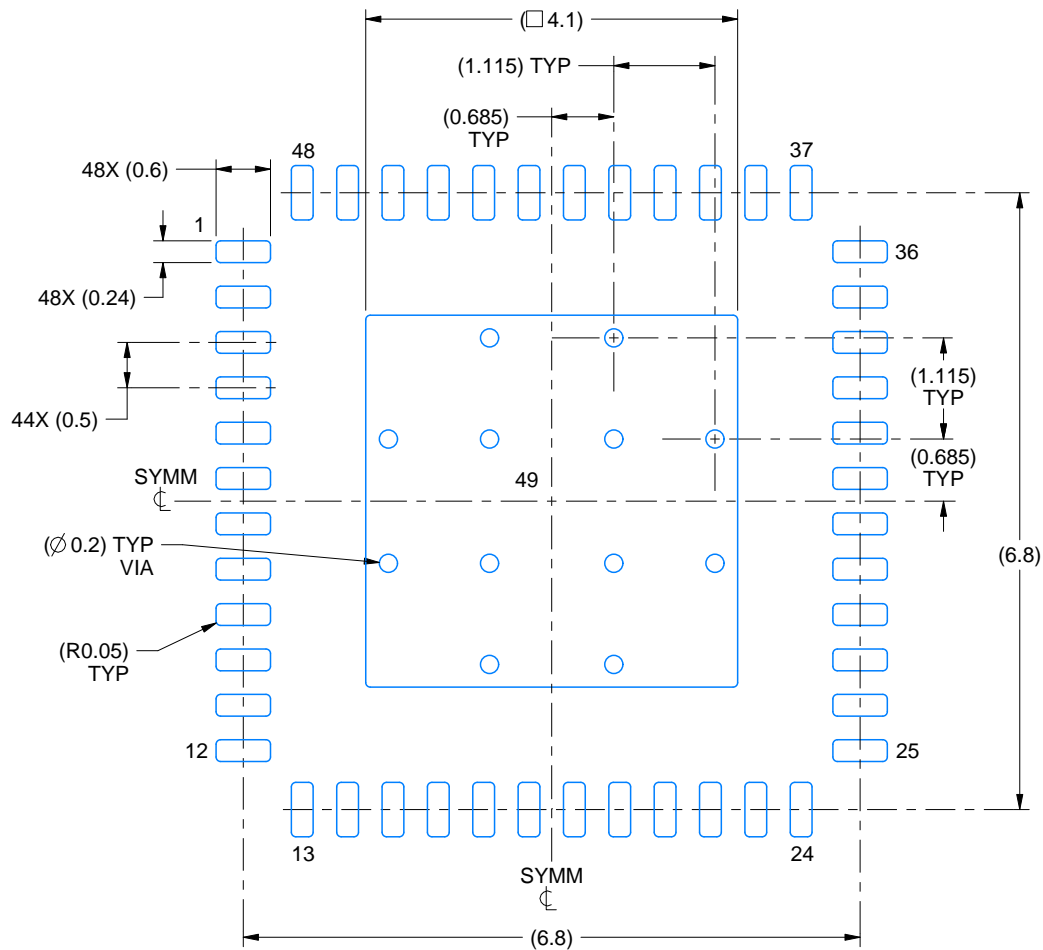

LAND PATTERN EXAMPLE
EXPOSED METAL SHOWN
SCALE:12X

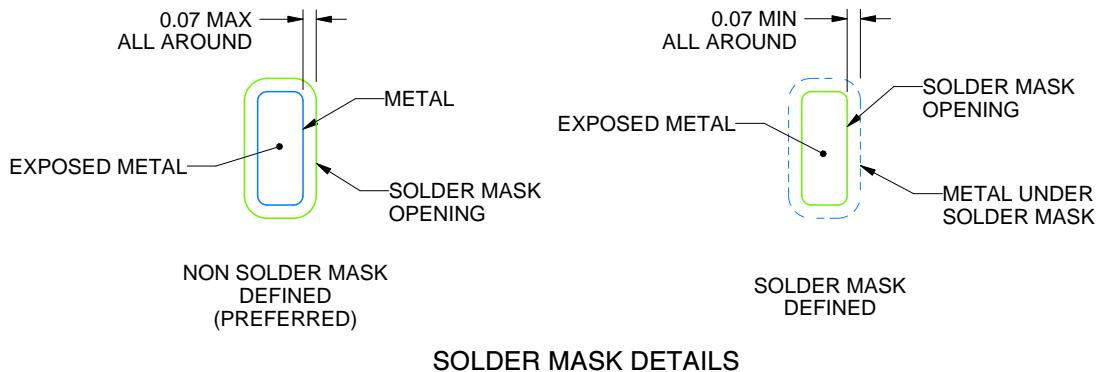

SOLDER MASK DETAILS

4218795/B 02/2017

NOTES: (continued)

4. This package is designed to be soldered to a thermal pad on the board. For more information, see Texas Instruments literature number SLUA271 (www.ti.com/lit/slua271).
5. Vias are optional depending on application, refer to device data sheet. If any vias are implemented, refer to their locations shown on this view. It is recommended that vias under paste be filled, plugged or tented.

EXAMPLE STENCIL DESIGN

RGZ0048B

VQFN - 1 mm max height

PLASTIC QUAD FLATPACK - NO LEAD

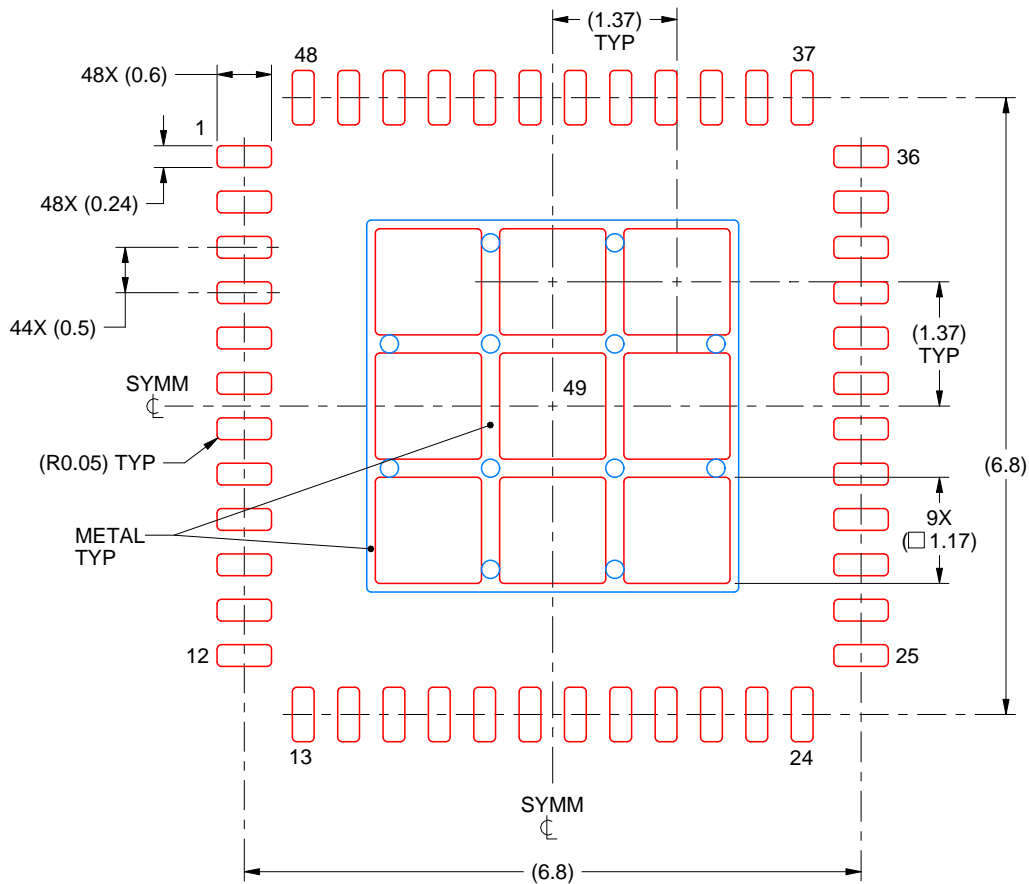

SOLDER PASTE EXAMPLE
 BASED ON 0.125 mm THICK STENCIL

EXPOSED PAD 49
 73% PRINTED SOLDER COVERAGE BY AREA UNDER PACKAGE
 SCALE:12X

4218795/B 02/2017

NOTES: (continued)

- 6. Laser cutting apertures with trapezoidal walls and rounded corners may offer better paste release. IPC-7525 may have alternate design recommendations.

重要声明和免责声明

TI 均以“原样”提供技术性 & 可靠性数据（包括数据表）、设计资源（包括参考设计）、应用或其他设计建议、网络工具、安全信息和其他资源，不保证其中不含任何瑕疵，且不做任何明示或暗示的担保，包括但不限于对适销性、适合某特定用途或不侵犯任何第三方知识产权的暗示担保。

所述资源可供专业开发人员应用 TI 产品进行设计使用。您将对以下行为独自承担全部责任：(1) 针对您的应用选择合适的 TI 产品；(2) 设计、验证并测试您的应用；(3) 确保您的应用满足相应标准以及任何其他安全、安保或其他要求。所述资源如有变更，恕不另行通知。TI 对您使用所述资源的授权仅限于开发资源所涉及 TI 产品的相关应用。除此之外不得复制或展示所述资源，也不提供其它 TI 或任何第三方的知识产权授权许可。如因使用所述资源而产生任何索赔、赔偿、成本、损失及债务等，TI 对此概不负责，并且您须赔偿由此对 TI 及其代表造成的损害。

TI 所提供产品均受 TI 的销售条款 (<http://www.ti.com.cn/zh-cn/legal/termsofsale.html>) 以及 [ti.com.cn](http://www.ti.com.cn) 上或随附 TI 产品提供的其他可适用条款的约束。TI 提供所述资源并不扩展或以其他方式更改 TI 针对 TI 产品所发布的可适用的担保范围或担保免责声明。

邮寄地址：上海市浦东新区世纪大道 1568 号中建大厦 32 楼，邮政编码：200122

Copyright © 2020 德州仪器半导体技术（上海）有限公司

X-ON Electronics

Largest Supplier of Electrical and Electronic Components

Click to view similar products for [Power Management Specialised - PMIC category:](#)

Click to view products by [Texas Instruments manufacturer:](#)

Other Similar products are found below :

[FAN7710VN](#) [SLG7NT4081VTR](#) [SLG7NT4192VTR](#) [AS3729B-BWLM](#) [MB39C831QN-G-EFE2](#) [LV56841PVD-XH](#) [L9781TR](#) [P91E0-15NHGI](#) [S6AE102A0DGN1B200](#) [L9916](#) [AP4306BUKTR-G1](#) [SLG7NT4198V](#) [NCP392CSFCCT1G](#) [LPTM21L-1ABG100I](#) [ISL69234IRAZ-T](#) [ISL69259IRAZ](#) [ISL69228IRAZ](#) [ISL69269IRAZ](#) [TPS53679RSBR](#) [AXP813](#) [FAN53870UC00X](#) [FDMF5085](#) [HPM10-W29A100G](#) [NCV97311MW50R2G](#) [WL2868C-20/TR](#) [TLE9263-3BQX](#) [TLE9263QX](#) [TEA2095T/1J](#) [TEA2017AAT/2Y](#) [TPS650940A0RSKR](#) [LP2998MAX](#) [TPS65177ARHAR](#) [LTC4359HMS8#TRPBF](#) [LTC4417IUF#TRPBF](#) [LTC4357MPMS8#TRPBF](#) [AXP717](#) [SQ24806AQSC](#) [RK805-2](#) [RK809-2](#) [MFS2633AMBA0AD](#) [MFS2613AMDA3AD](#) [MP5496GR-0001-Z](#) [MP5515GU-Z](#) [LTC4357HMS8#TRPBF](#) [LTC4353CMS#TRPBF](#) [AD5522JSVUZ-RL](#) [LTC4352CMS#TRPBF](#) [LTC4417CUF#TRPBF](#) [LTC4359HDCB#TRPBF](#) [LTC4359CMS8#TRPBF](#)