

80mA, 10V, 3.2 μ A Quiescent Current LOW-DROPOUT LINEAR REGULATOR in SC70 or SON 2x2

FEATURES

- **Wide Input Voltage Range: 2.5V to 10V**
- **Low Quiescent Current: 3.2 μ A at 80mA**
- **Stable with any Capacitor > 0.47 μ F**
- **Output Current: 80mA**
- **Dropout Voltage: 415mV at 50mA Load**
- **Available in Fixed 3.3V or Adjustable (1.2V to 8.8V) Versions**
- **Current Limit**
- **SC70-5 and 2mm x 2mm SON-6 Packages**
- **Specified Junction Temperature Range: –40°C to +125°C**
- **For MSP430-Specific Output Voltages, see the [TPS715xx](#)**

APPLICATIONS

- **Ultralow-Power Microcontrollers**
- **Industrial/Automotive Applications**
- **PDA's**
- **Portable, Battery-Powered Equipment**

DESCRIPTION

The TPS714xx low-dropout (LDO) voltage regulators offer the benefits of wide input voltage range, low-dropout voltage, low-power operation, and miniaturized packaging. These devices, which operate over an input range of 2.5V to 10V, are stable with any capacitor \geq 0.47 μ F. The 2.5V to 10V input voltage range, combined with 3.2 μ A quiescent current, makes this device particularly well-suited for two-cell alkaline, and two-cell lithium, and other low quiescent current sensitive battery applications. The low dropout voltage and low quiescent current allow operation at extremely low power levels. Therefore, the devices are ideal for power battery management ICs. Specifically, because the device is enabled as soon as the applied voltage reaches the minimum input voltage, the output is quickly available to power continuously-operating, battery-charging ICs.

The typical PNP pass transistor has been replaced by a PMOS pass element. Because the PMOS pass element behaves as a low-value resistor, the low dropout voltage (typically 415mV at 50mA of load current) is directly proportional to the load current. The quiescent current (3.2 μ A, typical) is stable over the entire range of the output load current (0mA to 80mA).

The TPS714xx is available in a 2mm x 2mm SON-6 package ideal for high power dissipation, or an SC70-5 package ideal for handheld and ultra-portable applications.

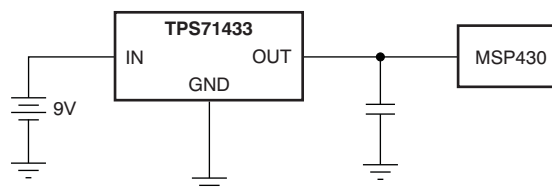
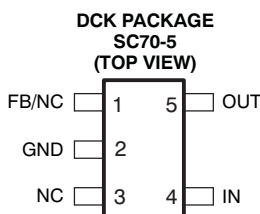
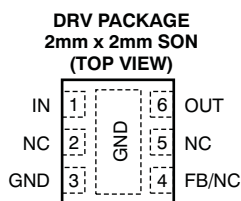

Please be aware that an important notice concerning availability, standard warranty, and use in critical applications of Texas Instruments semiconductor products and disclaimers thereto appears at the end of this data sheet.

All trademarks are the property of their respective owners.



This integrated circuit can be damaged by ESD. Texas Instruments recommends that all integrated circuits be handled with appropriate precautions. Failure to observe proper handling and installation procedures can cause damage.

ESD damage can range from subtle performance degradation to complete device failure. Precision integrated circuits may be more susceptible to damage because very small parametric changes could cause the device not to meet its published specifications.

AVAILABLE OPTIONS⁽¹⁾

PRODUCT	V _{OUT} ⁽²⁾
TPS714xxyyyz	XX is nominal output voltage (for example 33 = 3.3V, 01 = Adjustable) YYY is Package Designator Z is Package Quantity

- (1) For the most current package and ordering information see the Package Option Addendum at the end of this document, or see the TI web site at www.ti.com.
- (2) Custom output voltages are available on a quick-turn basis for prototyping. Production quantities are available; minimum package order quantities apply. Contact factory for details and availability.

ABSOLUTE MAXIMUM RATINGS

Over operating temperature range, unless otherwise noted.⁽¹⁾

PARAMETER	TPS714xx	UNIT
V _{IN} range	–0.3 to +24	V
V _{OUT} range	–0.3 to +9.9	V
V _{FB} range	–0.3 to +4	V
Peak output current	Internally limited	
Continuous total power dissipation	See Power Dissipation Rating table	
Junction temperature range, T _J	–40 to +125	°C
Storage temperature range	–65 to +150	°C
ESD rating	Human body model (HBM)	2 kV
	Charged device model (CDM)	500 V

- (1) Stresses beyond those listed under *Absolute Maximum Ratings* may cause permanent damage to the device. These are stress ratings only, and functional operation of the device at these or any other conditions beyond those indicated is not implied. Exposure to absolute-maximum-rated conditions for extended periods may affect device reliability.

POWER DISSIPATION RATING TABLE

BOARD	PACKAGE	R _{θJA} °C/W	DERATING FACTOR ABOVE T _A = +25°C	T _A ≤ 25°C POWER RATING	T _A = +70°C POWER RATING	T _A = +85°C POWER RATING
High-K ⁽¹⁾	DCK	315	3.18mW/°C	320mW	175mW	100mW
High-K ⁽¹⁾	DRV	65	15.4mW/°C	1.54W	850mW	0.62W

- (1) The JEDEC High-K (2s2p) board design used to derive this data was a 3 inch × 3 inch, multilayer board with 1-ounce internal power and ground planes and 2-ounce copper traces on top and bottom of the board.

ELECTRICAL CHARACTERISTICS

Over the operating junction temperature range ($T_J = -40^\circ\text{C}$ to $+125^\circ\text{C}$), $V_{IN} = V_{OUT(NOM)} + 1\text{V}$, $I_{OUT} = 1\text{mA}$, and $C_{OUT} = 1\mu\text{F}$, unless otherwise noted. The adjustable version is tested with $V_{OUT} = 2.8\text{V}$. Typical values are at $T_J = +25^\circ\text{C}$.

PARAMETER	TEST CONDITIONS	TPS714xx			UNIT	
		MIN	TYP	MAX		
Input voltage range ⁽¹⁾	V_{IN}	$I_{OUT} = 10\text{mA}$	2.5	10	V	
		$I_{OUT} = 80\text{mA}$	3	10		
Output voltage range (TPS71401)	V_{OUT}		V_{FB}	8.8	V	
Internal reference (TPS71401)	V_{FB}		1.12	1.20	1.24	V
Output voltage accuracy ⁽¹⁾	TPS71433 over V_{IN} , I_{OUT} , and Temp $4.3\text{V} < V_{IN} < 10\text{V}$, $1\text{mA} \leq I_{OUT} \leq 80\text{mA}$		3.135	3.3	3.465	V
Output voltage line regulation ⁽¹⁾	$\Delta V_{OUT}/\Delta V_{IN}$ $V_{OUT} + 1\text{V} < V_{IN} \leq 10\text{V}$			5		mV
Load regulation	$\Delta V_{OUT}/\Delta I_{OUT}$ $I_{OUT} = 1\text{mA}$ to 80mA			30		mV
Feedback pin bias current	$I_{FB\ BIAS}$ $I_{OUT} = 0\text{mA}$, $V_{IN} = 3\text{V}$ to 10V , $V_{OUT} = 1.2\text{V}$,			2		nA
Dropout voltage	V_{DO} $I_{OUT} = 80\text{mA}$, $V_{IN} = V_{OUT(NOM)} - 0.1\text{V}$			670	1300	mV
Output current limit	I_{CL} $V_{OUT} = 0\text{V}$			100	1100	mA
Ground pin current	I_{GND}	$T_J = -40^\circ\text{C}$ to $+85^\circ\text{C}$, $1\text{mA} \leq I_{OUT} \leq 80\text{mA}$		3.2	4.2	μA
		$1\text{mA} \leq I_{OUT} \leq 80\text{mA}$		3.2	5.8	
		$V_{IN} = 10\text{V}$, $1\text{mA} \leq I_{OUT} \leq 80\text{mA}$			7.4	
Power-supply ripple rejection	PSRR $f = 100\text{kHz}$, $C_{OUT} = 10\mu\text{F}$			60		dB
Output noise voltage	V_{IN} BW = 200Hz to 100kHz, $C_{OUT} = 10\mu\text{F}$, $I_{OUT} = 50\text{mA}$			575		μVrms

(1) Minimum $V_{IN} = V_{OUT} + V_{DO}$, or the value shown for Input voltage, whichever is greater.

PIN CONFIGURATION

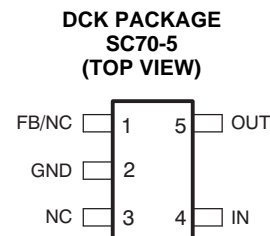
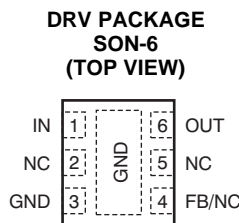

Table 1. Pin Descriptions

TPS714xx					DESCRIPTION
NAME	DCK		DRV		
	FIXED	ADJ.	FIXED	ADJ.	
FB/NC	-	1	-	4	Adjustable version only. This pin is used to set the output voltage.
GND	2	2	3, Pad	3, Pad	Ground
NC	1,3	3	2, 4, 5	2, 5	No connection. May be left open or tied to ground for improved thermal performance.
IN	4	4	1	1	Unregulated input voltage.
OUT	5	5	6	6	Regulated output voltage. Any output capacitor $\geq 0.47\mu\text{F}$ can be used for stability.

FUNCTIONAL BLOCK DIAGRAMS

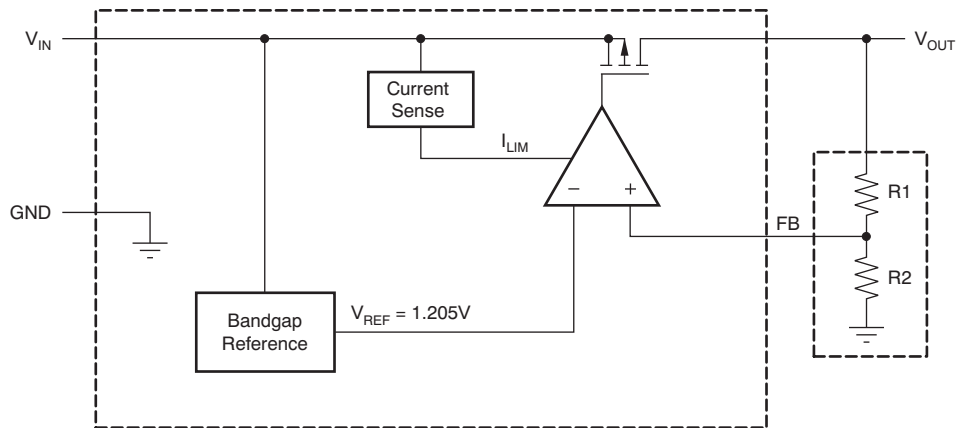

Figure 1. Adjustable Voltage Version

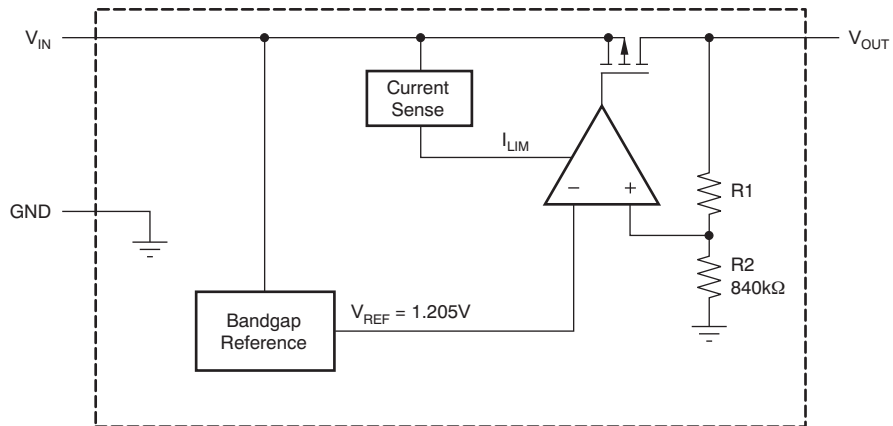

Figure 2. Fixed Voltage Version

TYPICAL CHARACTERISTICS

At $T_A = +25^\circ\text{C}$, unless otherwise noted.

**TPS71433
OUTPUT VOLTAGE
vs
OUTPUT CURRENT**

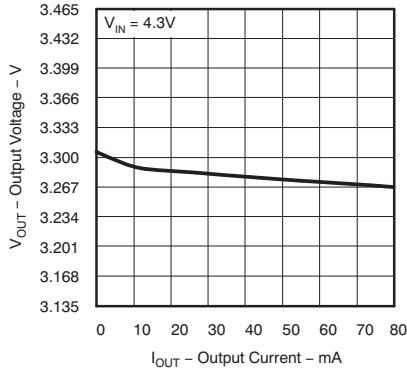

Figure 3.

**TPS71433
OUTPUT VOLTAGE
vs
JUNCTION TEMPERATURE**

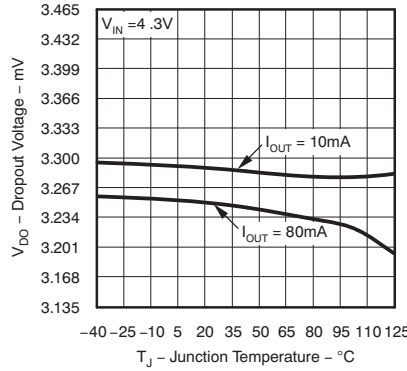

Figure 4.

**TPS71433
QUIESCENT CURRENT
vs
JUNCTION TEMPERATURE**

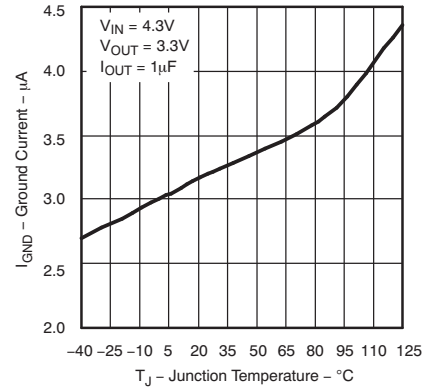

Figure 5.

**TPS71433
OUTPUT SPECTRAL NOISE DENSITY
vs
FREQUENCY**

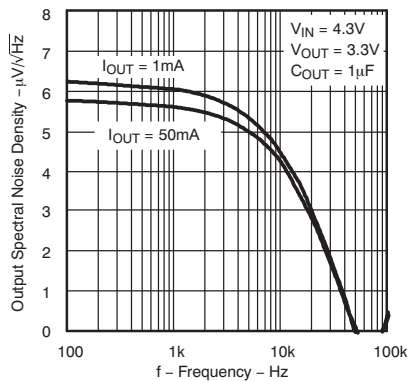

Figure 6.

**TPS71433
OUTPUT IMPEDANCE
vs
FREQUENCY**

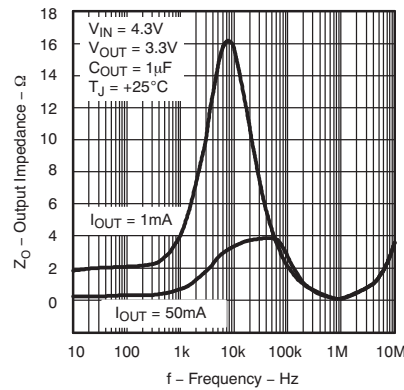

Figure 7.

**TPS71433
DROPOUT VOLTAGE
vs
OUTPUT CURRENT**

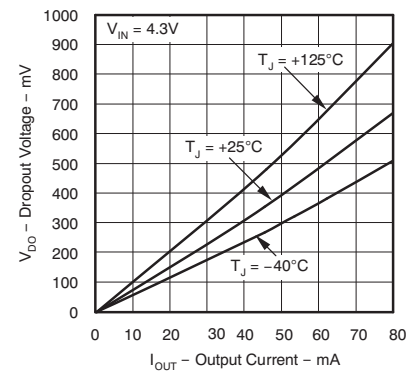

Figure 8.

TYPICAL CHARACTERISTICS (continued)

At $T_A = +25^\circ\text{C}$, unless otherwise noted.

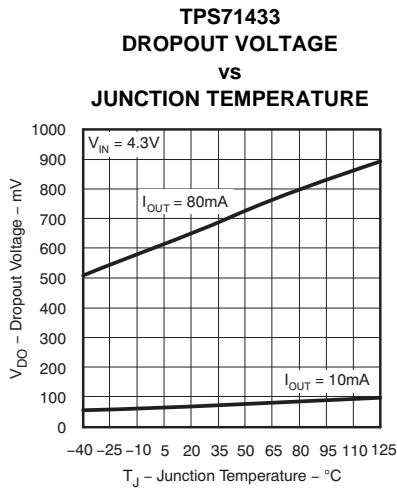

Figure 9.

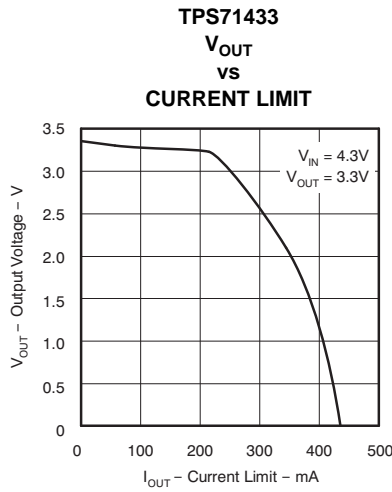

Figure 10.

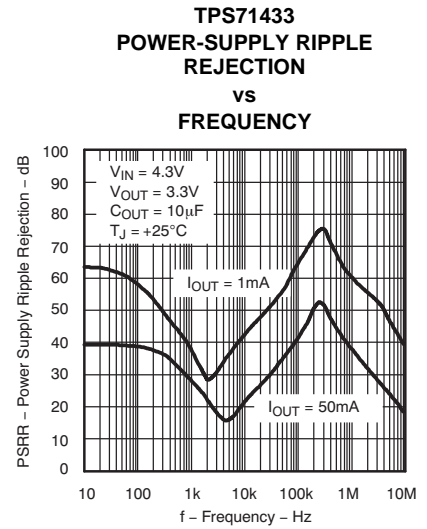

Figure 11.

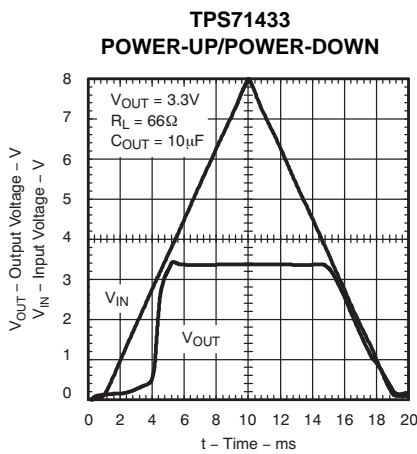

Figure 12.

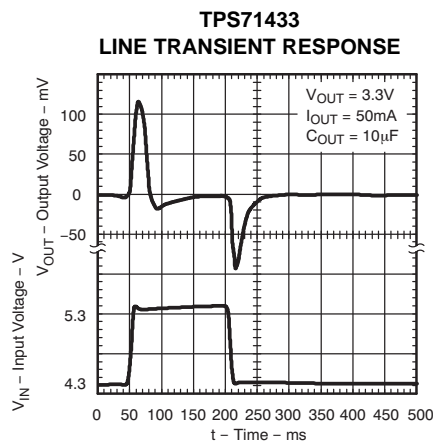

Figure 13.

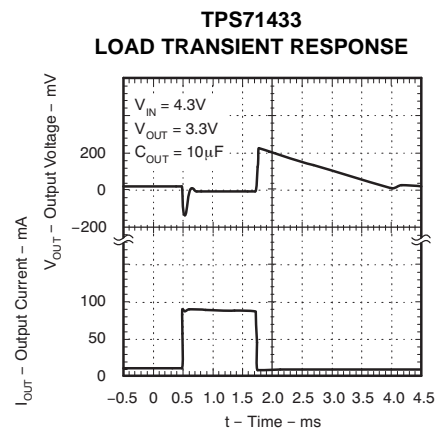

Figure 14.

APPLICATION INFORMATION

The TPS714xx family of LDO regulators has been optimized for ultralow power applications such as the [MSP430](#) microcontroller. Its ultralow supply current maximizes efficiency at light loads, and its high input voltage range makes it suitable for supplies such as unconditioned solar panels.

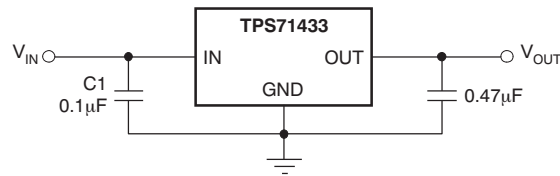

Figure 15. Typical Application Circuit (Fixed Voltage Version)

External Capacitor Requirements

Although not required, a 0.047μF or larger input bypass capacitor, connected between IN and GND and located close to the device, is recommended to improve transient response and noise rejection of the power supply as a whole. A higher-value input capacitor may be necessary if large, fast-rise-time load transients are anticipated and if the device is located several inches from the power source.

The TPS714xx requires an output capacitor connected between OUT and GND to stabilize the internal control loop. Any capacitor (including ceramic and tantalum) that is greater than or equal to 0.47μF properly stabilizes this loop.

Power Dissipation and Junction Temperature

To ensure reliable operation, worst-case junction temperature should not exceed +125°C. This restriction limits the power dissipation that the regulator can manage in any given application. To ensure the junction temperature is within acceptable limits, calculate the maximum allowable dissipation, $P_{D(MAX)}$, and the actual dissipation, P_D , which must be less than or equal to $P_{D(max)}$.

The maximum-power-dissipation limit is determined using [Equation 1](#):

$$P_{D(max)} = \frac{T_{Jmax} - T_A}{R_{\theta JA}}$$

Where:

- T_{Jmax} is the maximum allowable junction temperature.
- $R_{\theta JA}$ is the thermal resistance junction-to-ambient for the package (see the [Power Dissipation Rating](#) table).
- T_A is the ambient temperature.

(1)

The regulator dissipation is calculated using [Equation 2](#):

$$P_D = (V_{IN} - V_{OUT}) \times I_{OUT}$$

(2)

Power dissipation resulting from quiescent current is negligible.

Regulator Protection

The TPS714xx PMOS-pass transistor has a built-in back diode that conducts reverse current when the input voltage drops below the output voltage (for example, during power-down). Current is conducted from the output to the input and is not internally limited. If extended reverse voltage operation is anticipated, external limiting might be appropriate.

The TPS714xx features internal current limiting. During normal operation, the TPS714xx limits output current to approximately 500mA. When current limiting engages, the output voltage scales back linearly until the over-current condition ends. There is no internal thermal shutdown circuit in this device; therefore, care must be taken not to exceed the power dissipation ratings of the package during a fault condition. This device does not have undervoltage lockout; therefore, this constraint should be taken into consideration for specific applications.

Programming the TPS71401 Adjustable LDO Regulator

The output voltage of the TPS71401 adjustable regulator is programmed using an external resistor divider as shown in [Figure 16](#). The output voltage is calculated using [Equation 3](#):

$$V_{OUT} = V_{REF} \times \left(1 + \frac{R1}{R2} \right) \quad (3)$$

where:

$$V_{REF} = 1.20V \text{ typ (the internal reference voltage)}$$

Resistors R1 and R2 should be chosen for approximately a 1.5µA divider current. Lower value resistors can be used for improved noise performance, but the solution consumes more power. Higher resistor values should be avoided because leakage current out of the FB pin across R1/R2 creates an offset voltage that artificially increases the feedback voltage and thus erroneously decreases V_{OUT} . The recommended design procedure is to choose $R2 = 1M\Omega$ to set the divider current at 1.5µA, and then calculate R1 using [Equation 4](#):

$$R1 = \left(\frac{V_{OUT}}{V_{REF}} - 1 \right) \times R2 \quad (4)$$

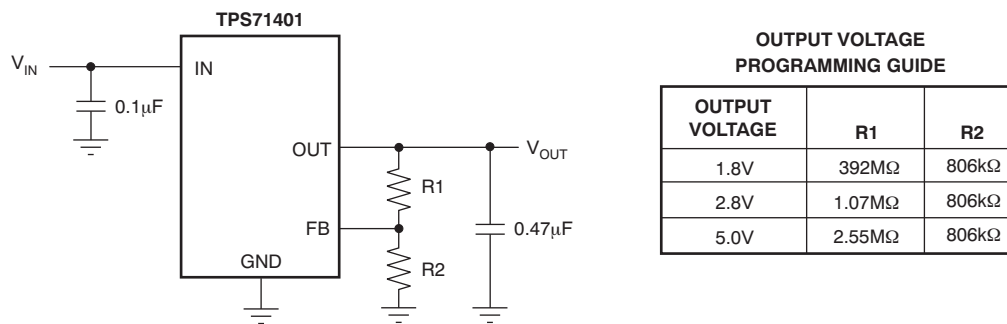

Figure 16. TPS71401 Adjustable LDO Regulator Programming

REVISION HISTORY

NOTE: Page numbers for previous revisions may differ from page numbers in the current version.

Changes from Revision B (December, 2009) to Revision C Page

- Changed *Ground pin current* maximum specifications 3
-

Changes from Revision A (April, 2009) to Revision B Page

- Changed battery type shown in typical circuit illustration 1
 - Changed V_{IN} range absolute maximum rating from +11.5V to +24V 2
-

PACKAGING INFORMATION

Orderable Device	Status (1)	Package Type	Package Drawing	Pins	Package Qty	Eco Plan (2)	Lead finish/ Ball material (6)	MSL Peak Temp (3)	Op Temp (°C)	Device Marking (4/5)	Samples
TPS71401DCKR	ACTIVE	SC70	DCK	5	3000	RoHS & Green	NIPDAUAG	Level-1-260C-UNLIM	-40 to 125	CVG	Samples
TPS71401DCKT	ACTIVE	SC70	DCK	5	250	RoHS & Green	NIPDAUAG	Level-1-260C-UNLIM	-40 to 125	CVG	Samples
TPS71401DRVR	ACTIVE	WSON	DRV	6	3000	RoHS & Green	NIPDAU	Level-1-260C-UNLIM	-40 to 125	CVG	Samples
TPS71401DRVT	ACTIVE	WSON	DRV	6	250	RoHS & Green	NIPDAU	Level-1-260C-UNLIM	-40 to 125	CVG	Samples
TPS71433DCKR	ACTIVE	SC70	DCK	5	3000	RoHS & Green	NIPDAUAG	Level-1-260C-UNLIM	-40 to 125	CVH	Samples
TPS71433DCKT	ACTIVE	SC70	DCK	5	250	RoHS & Green	NIPDAUAG	Level-1-260C-UNLIM	-40 to 125	CVH	Samples
TPS71433DRVR	ACTIVE	WSON	DRV	6	3000	RoHS & Green	NIPDAU	Level-1-260C-UNLIM	-40 to 125	CVH	Samples
TPS71433DRVT	ACTIVE	WSON	DRV	6	250	RoHS & Green	NIPDAU	Level-1-260C-UNLIM	-40 to 125	CVH	Samples

(1) The marketing status values are defined as follows:

ACTIVE: Product device recommended for new designs.

LIFEBUY: TI has announced that the device will be discontinued, and a lifetime-buy period is in effect.

NRND: Not recommended for new designs. Device is in production to support existing customers, but TI does not recommend using this part in a new design.

PREVIEW: Device has been announced but is not in production. Samples may or may not be available.

OBSELETE: TI has discontinued the production of the device.

(2) **RoHS:** TI defines "RoHS" to mean semiconductor products that are compliant with the current EU RoHS requirements for all 10 RoHS substances, including the requirement that RoHS substance do not exceed 0.1% by weight in homogeneous materials. Where designed to be soldered at high temperatures, "RoHS" products are suitable for use in specified lead-free processes. TI may reference these types of products as "Pb-Free".

RoHS Exempt: TI defines "RoHS Exempt" to mean products that contain lead but are compliant with EU RoHS pursuant to a specific EU RoHS exemption.

Green: TI defines "Green" to mean the content of Chlorine (Cl) and Bromine (Br) based flame retardants meet JS709B low halogen requirements of <=1000ppm threshold. Antimony trioxide based flame retardants must also meet the <=1000ppm threshold requirement.

(3) MSL, Peak Temp. - The Moisture Sensitivity Level rating according to the JEDEC industry standard classifications, and peak solder temperature.

(4) There may be additional marking, which relates to the logo, the lot trace code information, or the environmental category on the device.

(5) Multiple Device Markings will be inside parentheses. Only one Device Marking contained in parentheses and separated by a "~" will appear on a device. If a line is indented then it is a continuation of the previous line and the two combined represent the entire Device Marking for that device.

⁽⁶⁾ Lead finish/Ball material - Orderable Devices may have multiple material finish options. Finish options are separated by a vertical ruled line. Lead finish/Ball material values may wrap to two lines if the finish value exceeds the maximum column width.

Important Information and Disclaimer: The information provided on this page represents TI's knowledge and belief as of the date that it is provided. TI bases its knowledge and belief on information provided by third parties, and makes no representation or warranty as to the accuracy of such information. Efforts are underway to better integrate information from third parties. TI has taken and continues to take reasonable steps to provide representative and accurate information but may not have conducted destructive testing or chemical analysis on incoming materials and chemicals. TI and TI suppliers consider certain information to be proprietary, and thus CAS numbers and other limited information may not be available for release.

In no event shall TI's liability arising out of such information exceed the total purchase price of the TI part(s) at issue in this document sold by TI to Customer on an annual basis.

TAPE AND REEL INFORMATION

QUADRANT ASSIGNMENTS FOR PIN 1 ORIENTATION IN TAPE

*All dimensions are nominal

Device	Package Type	Package Drawing	Pins	SPQ	Reel Diameter (mm)	Reel Width W1 (mm)	A0 (mm)	B0 (mm)	K0 (mm)	P1 (mm)	W (mm)	Pin1 Quadrant
TPS71401DCKR	SC70	DCK	5	3000	180.0	8.4	2.41	2.41	1.2	4.0	8.0	Q3
TPS71401DCKT	SC70	DCK	5	250	180.0	8.4	2.41	2.41	1.2	4.0	8.0	Q3
TPS71401DRVR	WS0N	DRV	6	3000	179.0	8.4	2.2	2.2	1.2	4.0	8.0	Q2
TPS71401DRVT	WS0N	DRV	6	250	179.0	8.4	2.2	2.2	1.2	4.0	8.0	Q2
TPS71433DCKR	SC70	DCK	5	3000	180.0	8.4	2.41	2.41	1.2	4.0	8.0	Q3
TPS71433DCKT	SC70	DCK	5	250	180.0	8.4	2.41	2.41	1.2	4.0	8.0	Q3
TPS71433DRVR	WS0N	DRV	6	3000	179.0	8.4	2.2	2.2	1.2	4.0	8.0	Q2
TPS71433DRVT	WS0N	DRV	6	250	179.0	8.4	2.2	2.2	1.2	4.0	8.0	Q2

TAPE AND REEL BOX DIMENSIONS

*All dimensions are nominal

Device	Package Type	Package Drawing	Pins	SPQ	Length (mm)	Width (mm)	Height (mm)
TPS71401DCKR	SC70	DCK	5	3000	183.0	183.0	20.0
TPS71401DCKT	SC70	DCK	5	250	183.0	183.0	20.0
TPS71401DRVR	WSON	DRV	6	3000	200.0	183.0	25.0
TPS71401DRVT	WSON	DRV	6	250	203.0	203.0	35.0
TPS71433DCKR	SC70	DCK	5	3000	183.0	183.0	20.0
TPS71433DCKT	SC70	DCK	5	250	183.0	183.0	20.0
TPS71433DRVR	WSON	DRV	6	3000	200.0	183.0	25.0
TPS71433DRVT	WSON	DRV	6	250	203.0	203.0	35.0

DCK (R-PDSO-G5)

PLASTIC SMALL-OUTLINE PACKAGE



- NOTES:
- A. All linear dimensions are in millimeters.
 - B. This drawing is subject to change without notice.
 - C. Body dimensions do not include mold flash or protrusion. Mold flash and protrusion shall not exceed 0.15 per side.
 - D. Falls within JEDEC MO-203 variation AA.

DCK (R-PDSO-G5)

PLASTIC SMALL OUTLINE



- NOTES:
- A. All linear dimensions are in millimeters.
 - B. This drawing is subject to change without notice.
 - C. Customers should place a note on the circuit board fabrication drawing not to alter the center solder mask defined pad.
 - D. Publication IPC-7351 is recommended for alternate designs.
 - E. Laser cutting apertures with trapezoidal walls and also rounding corners will offer better paste release. Customers should contact their board assembly site for stencil design recommendations. Example stencil design based on a 50% volumetric metal load solder paste. Refer to IPC-7525 for other stencil recommendations.

GENERIC PACKAGE VIEW

DRV 6

WSON - 0.8 mm max height

PLASTIC SMALL OUTLINE - NO LEAD



Images above are just a representation of the package family, actual package may vary.
Refer to the product data sheet for package details.

4206925/F

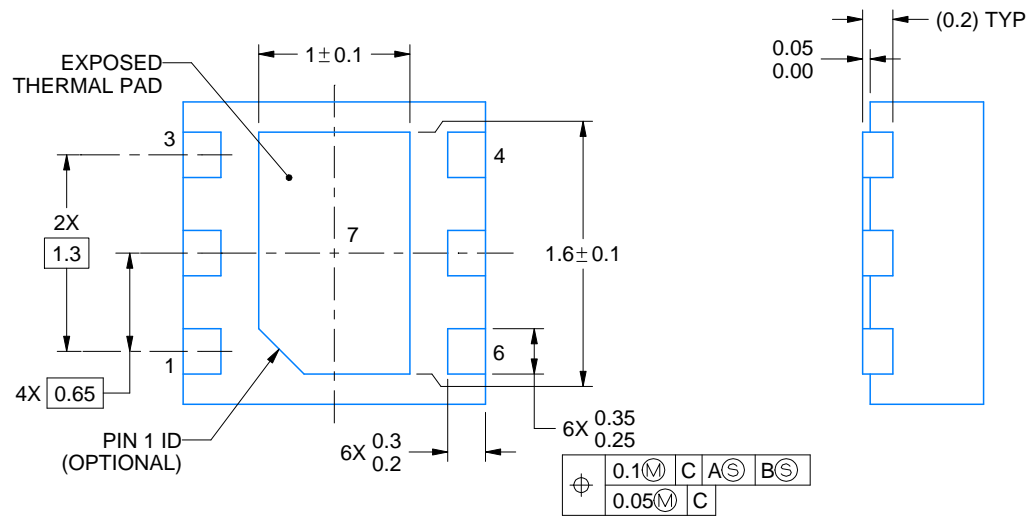
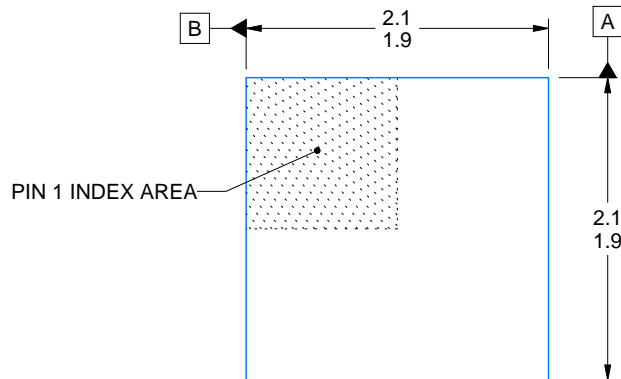
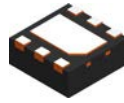

4222173/B 04/2018

NOTES:

1. All linear dimensions are in millimeters. Any dimensions in parenthesis are for reference only. Dimensioning and tolerancing per ASME Y14.5M.
2. This drawing is subject to change without notice.
3. The package thermal pad must be soldered to the printed circuit board for thermal and mechanical performance.

EXAMPLE BOARD LAYOUT

DRV0006A

WSON - 0.8 mm max height

PLASTIC SMALL OUTLINE - NO LEAD

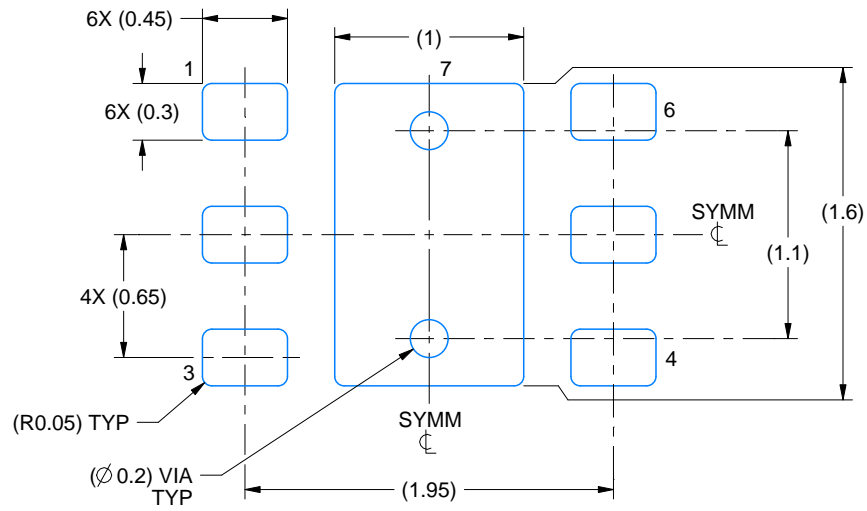

LAND PATTERN EXAMPLE
SCALE:25X

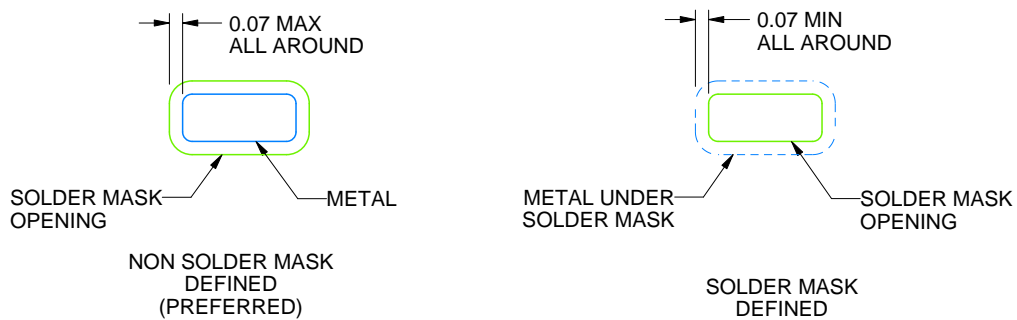

SOLDER MASK DETAILS

4222173/B 04/2018

NOTES: (continued)

4. This package is designed to be soldered to a thermal pad on the board. For more information, see Texas Instruments literature number SLUA271 (www.ti.com/lit/sluea271).
5. Vias are optional depending on application, refer to device data sheet. If some or all are implemented, recommended via locations are shown.

EXAMPLE STENCIL DESIGN

DRV0006A

WSON - 0.8 mm max height

PLASTIC SMALL OUTLINE - NO LEAD



SOLDER PASTE EXAMPLE
BASED ON 0.125 mm THICK STENCIL

EXPOSED PAD #7
88% PRINTED SOLDER COVERAGE BY AREA UNDER PACKAGE
SCALE:30X

4222173/B 04/2018

NOTES: (continued)

6. Laser cutting apertures with trapezoidal walls and rounded corners may offer better paste release. IPC-7525 may have alternate design recommendations.

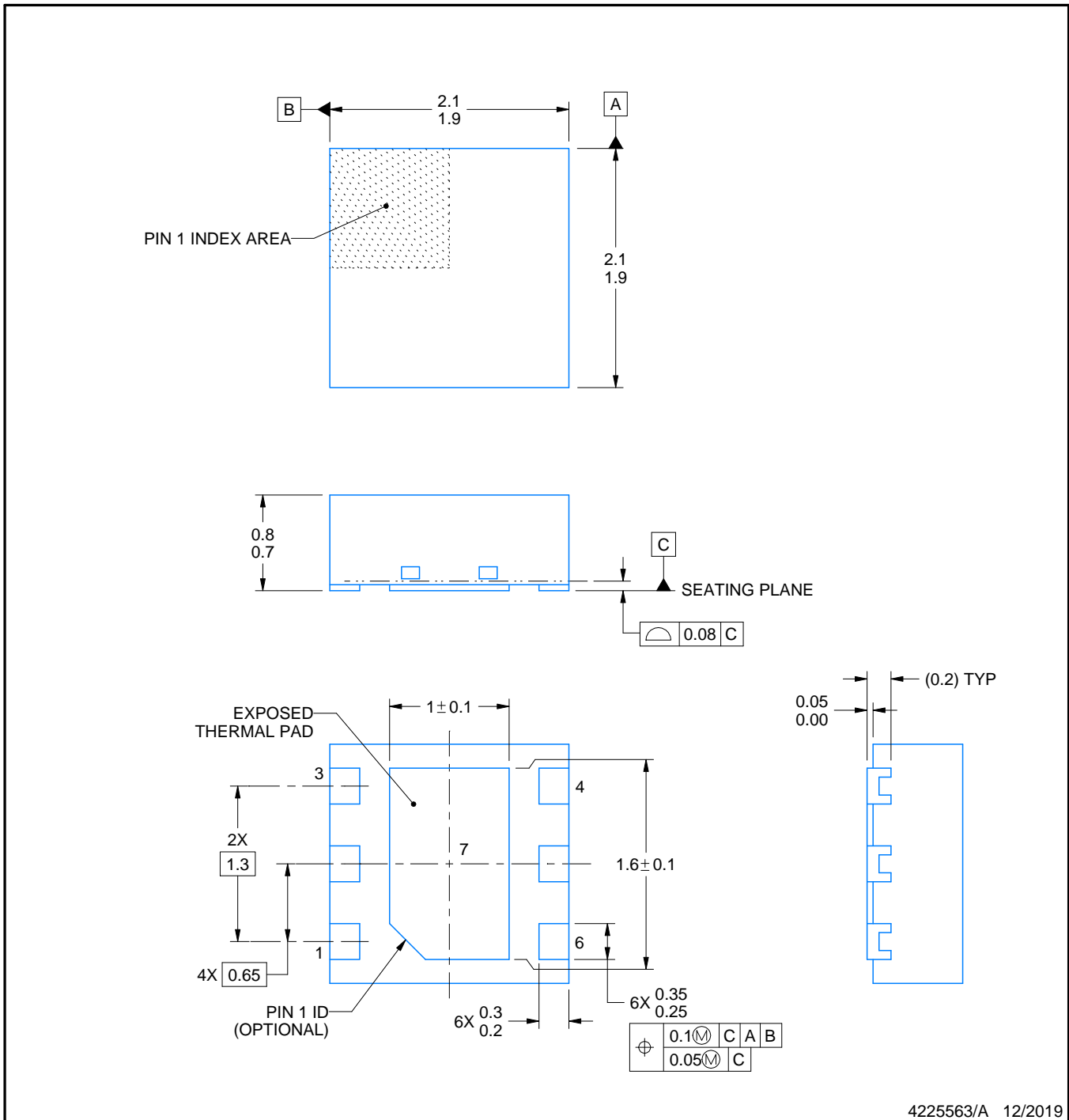
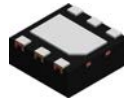

NOTES:

1. All linear dimensions are in millimeters. Any dimensions in parenthesis are for reference only. Dimensioning and tolerancing per ASME Y14.5M.
2. This drawing is subject to change without notice.
3. The package thermal pad must be soldered to the printed circuit board for thermal and mechanical performance.

EXAMPLE BOARD LAYOUT

DRV0006D

WSON - 0.8 mm max height

PLASTIC SMALL OUTLINE - NO LEAD



LAND PATTERN EXAMPLE
EXPOSED METAL SHOWN
SCALE:25X

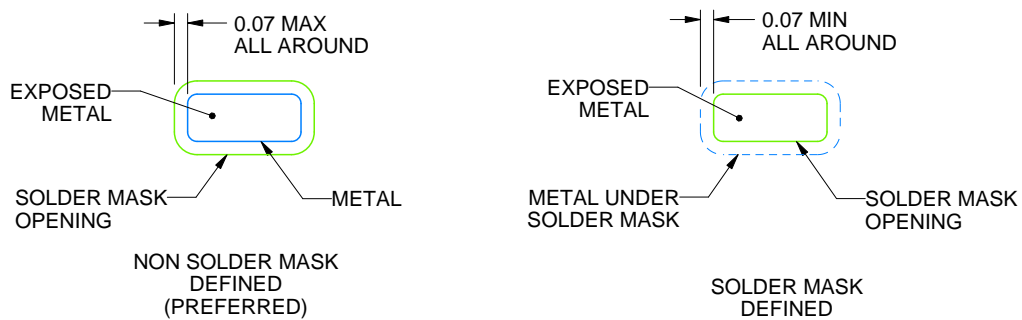

SOLDER MASK DETAILS

4225563/A 12/2019

NOTES: (continued)

- This package is designed to be soldered to a thermal pad on the board. For more information, see Texas Instruments literature number SLUA271 (www.ti.com/lit/sluea271).
- Vias are optional depending on application, refer to device data sheet. If some or all are implemented, recommended via locations are shown.

EXAMPLE STENCIL DESIGN

DRV0006D

WSON - 0.8 mm max height

PLASTIC SMALL OUTLINE - NO LEAD



SOLDER PASTE EXAMPLE
BASED ON 0.125 mm THICK STENCIL

EXPOSED PAD #7
88% PRINTED SOLDER COVERAGE BY AREA UNDER PACKAGE
SCALE:30X

4225563/A 12/2019

NOTES: (continued)

6. Laser cutting apertures with trapezoidal walls and rounded corners may offer better paste release. IPC-7525 may have alternate design recommendations.

IMPORTANT NOTICE AND DISCLAIMER

TI PROVIDES TECHNICAL AND RELIABILITY DATA (INCLUDING DATASHEETS), DESIGN RESOURCES (INCLUDING REFERENCE DESIGNS), APPLICATION OR OTHER DESIGN ADVICE, WEB TOOLS, SAFETY INFORMATION, AND OTHER RESOURCES "AS IS" AND WITH ALL FAULTS, AND DISCLAIMS ALL WARRANTIES, EXPRESS AND IMPLIED, INCLUDING WITHOUT LIMITATION ANY IMPLIED WARRANTIES OF MERCHANTABILITY, FITNESS FOR A PARTICULAR PURPOSE OR NON-INFRINGEMENT OF THIRD PARTY INTELLECTUAL PROPERTY RIGHTS.

These resources are intended for skilled developers designing with TI products. You are solely responsible for (1) selecting the appropriate TI products for your application, (2) designing, validating and testing your application, and (3) ensuring your application meets applicable standards, and any other safety, security, or other requirements. These resources are subject to change without notice. TI grants you permission to use these resources only for development of an application that uses the TI products described in the resource. Other reproduction and display of these resources is prohibited. No license is granted to any other TI intellectual property right or to any third party intellectual property right. TI disclaims responsibility for, and you will fully indemnify TI and its representatives against, any claims, damages, costs, losses, and liabilities arising out of your use of these resources.

TI's products are provided subject to TI's Terms of Sale (www.ti.com/legal/termsofsale.html) or other applicable terms available either on ti.com or provided in conjunction with such TI products. TI's provision of these resources does not expand or otherwise alter TI's applicable warranties or warranty disclaimers for TI products.

Mailing Address: Texas Instruments, Post Office Box 655303, Dallas, Texas 75265
Copyright © 2020, Texas Instruments Incorporated

X-ON Electronics

Largest Supplier of Electrical and Electronic Components

Click to view similar products for [LDO Voltage Regulators](#) category:

Click to view products by [Texas Instruments](#) manufacturer:

Other Similar products are found below :

[AP7363-SP-13](#) [NCV8664CST33T3G](#) [L79M05TL-E](#) [AP7362-HA-7](#) [PT7M8202B12TA5EX](#) [TCR3DF185,LM\(CT](#) [TLF4949EJ](#)
[NCP4687DH15T1G](#) [NCV8703MX30TCG](#) [LP2951CN](#) [NCV4269CPD50R2G](#) [AP7315-25W5-7](#) [NCV47411PAAJR2G](#) [AP2111H-1.2TRG1](#)
[ZLDO1117QK50TC](#) [AZ1117ID-ADJTRG1](#) [NCV4263-2CPD50R2G](#) [NCP114BMX075TCG](#) [MC33269T-3.5G](#) [TLE4471GXT](#) [AP7315-33SA-](#)
[7](#) [NCV4266-2CST33T3G](#) [NCP715SQ15T2G](#) [NCV8623MN-50R2G](#) [NCV563SQ18T1G](#) [NCV8664CDT33RKG](#) [NCV4299CD250R2G](#)
[NCP715MX30TBG](#) [NCV8702MX25TCG](#) [TLE7270-2E](#) [NCV562SQ25T1G](#) [AP2213D-3.3TRG1](#) [AP2202K-2.6TRE1](#)
[NCV8170BMX300TCG](#) [NCV8152MX300180TCG](#) [NCP700CMT45TBG](#) [AP7315-33W5-7](#) [NCP154MX180300TAG](#) [AP2113AMTR-G1](#)
[NJV4104U2-33A-TE1](#) [MP2013AGG-5-P](#) [NCV8775CDT50RKG](#) [NJM2878F3-45-TE1](#) [S-19214B00A-V5T2U7](#) [S-19214B50A-V5T2U7](#) [S-](#)
[19213B50A-V5T2U7](#) [S-19214BC0A-E8T1U7*1](#) [S-19213B00A-V5T2U7](#) [S-19213B33A-V5T2U7](#) [S-19213BC0A-V5T2U7](#)