

TPS92411x 用于对具有低纹波电流的发光二极管 (LED) 进行离线交流线性直接驱动的浮动开关

1 特性

- 通过交流电源驱动 LED 的高性能解决方案
- 用高功率因数、低总谐波失真和低电流纹波简化相位可调光 LED 驱动器的设计
- 适用于功率高达 70W 以上的 LED 光源
- 输入电压范围：7.5V 至 100V
- 可堆叠 100V，2Ω 金属氧化物半导体场效应晶体管 (MOSFET) 构造块
- 受控开关打开和关闭转换最大限度减少了电磁干扰 (EMI)
- 专用于与 TPS92410 或离散线性稳压器配套使用
- 输入欠压保护
- 输出过压保护 (TPS92411P)
- 低 I_Q ：200μA (典型值)

2 应用

- LED 灯和灯泡
- LED 光源
- 射灯

3 说明

TPS92411 是一款在离线 LED 照明应用中使用的 100V 浮动 MOSFET 开关。该器件与能够实现功率因数大于 0.9 的电流稳压器一同使用，从而构建具有低纹波电流的 LED 驱动解决方案。当设计正确时，解决方案性能与基于传统反激式降压或升压的交流/直流 LED 驱动器类似。此方法无需电感器元件，因此减小了尺寸并节约了成本。TPS92411 开关的受控转换式低频操作可产生超低的 EMI。详细操作，请参见 [应用信息](#) 部分中说明。

封装选项包括小外形尺寸晶体管 (SOT)23-5 和 PSOP-8，这使得用户能够针对小尺寸进行优化，或针对高功率进行缩放。利用 PSOP-8 封装，LED 光源的设计有可能高达 70W 或更高。其他特性包括用于监控器件何时具有正常运转所需的足够电压的欠压闭锁 (UVLO) 电路，以及过压保护功能 (TPS92411P)。

器件信息(1)

部件号	封装	封装尺寸 (标称值)
TPS92411, TPS92411P	SOT-23 (5)	2.90mm x 1.60mm
	SO PowerPAD (8)	4.89mm x 3.90mm

(1) 如需了解所有可用封装，请见数据表末尾的可订购产品附录。

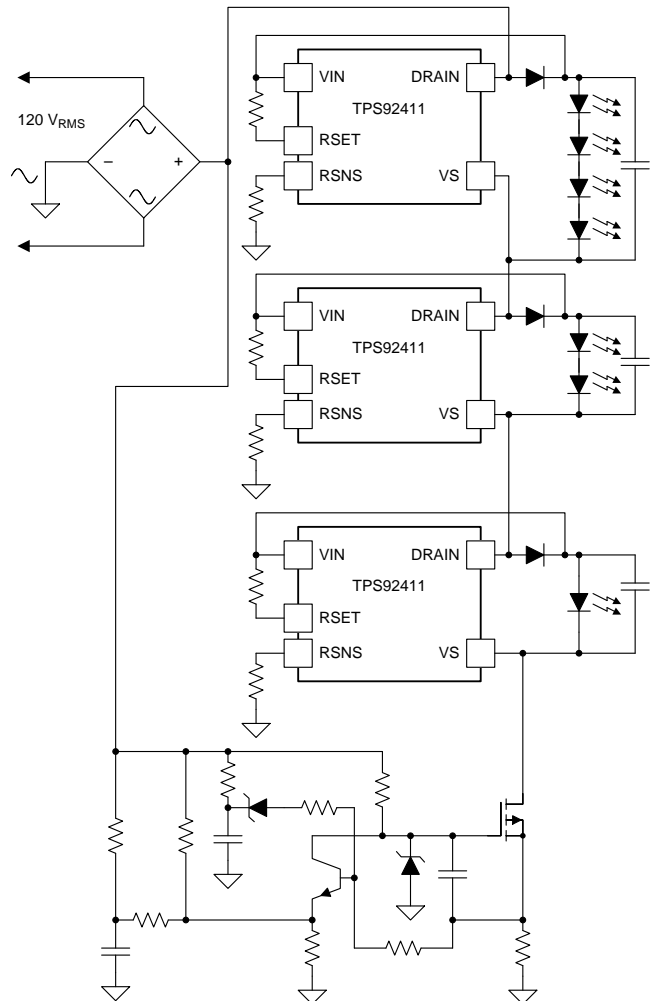

目录

1	特性	1	7.3	Feature Description	9
2	应用	1	7.4	Device Functional Modes	10
3	说明	1	8	Application and Implementation	11
4	修订历史记录	2	8.1	Application Information	11
5	Pin Configuration and Functions	3	8.2	Typical Application	12
6	Specifications	3	9	Power Supply Recommendations	18
6.1	Absolute Maximum Ratings	3	10	Layout	18
6.2	Handling Ratings	3	10.1	Layout Guidelines	18
6.3	Recommended Operating Conditions	4	10.2	Layout Example	18
6.4	Thermal Information	4	11	器件和文档支持	19
6.5	Electrical Characteristics	4	11.1	相关链接	19
6.6	Typical Characteristics	6	11.2	商标	19
7	Detailed Description	8	11.3	静电放电警告	19
7.1	Overview	8	11.4	术语表	19
7.2	Functional Block Diagram	8	12	机械封装和可订购信息	19

4 修订历史记录

Changes from Revision A (May 2014) to Revision B	Page
<ul style="list-style-type: none"> 已添加 添加了引脚配置和功能部分，处理额定值表、特性描述部分，器件功能模式，应用和实施部分，电源相关建议部分，布局部分，器件和文档支持部分以及机械、封装和可订购信息部分 	1

Changes from Original (October 2013) to Revision A	Page
<ul style="list-style-type: none"> Deleted preview designation for DDA package 	3
<ul style="list-style-type: none"> Added availability information for DDA package 	3

5 Pin Configuration and Functions



Pin Functions

NAME	PIN NO.		I/O	DESCRIPTION
	DDA	DBV		
DRAIN	8	4	O	Drain of the internal switch.
N/C	2	—	—	Not internally connected.
N/C	6			
N/C	7			
VIN	1	3	I	Positive power supply for the device.
VS	4	2	I/O	Source of the internal switch. This pin is also the device floating ground.
RSET	3	1	I/O	A resistor connected between the RSET pin and the VIN pin sets the rising threshold to open the switch.
RSNS	5	5	I/O	A resistor connected between the RSNS pin to system ground senses the VS voltage relative to system ground.
Exposed Thermal Pad				Connect to VS pin directly beneath the device.

6 Specifications

6.1 Absolute Maximum Ratings

All voltages are with respect to VS, $-40\text{ }^{\circ}\text{C} < T_J = T_A \leq 150\text{ }^{\circ}\text{C}$. All currents are positive into and negative out of the specified terminal (unless otherwise noted).

		MIN	MAX	UNIT
Supply voltage	VIN	-0.3	105	V
Switch voltage	DRAIN	-0.3	105	
Junction temperature	T_J	-40	165	$^{\circ}\text{C}$

6.2 Handling Ratings

		MIN	MAX	UNIT	
T_{stg}	Storage temperature range	-65	150	$^{\circ}\text{C}$	
$V_{\text{(ESD)}}$	Electrostatic discharge	Human body model (HBM), per ANSI/ESDA/JEDEC JS-001, all pins ⁽¹⁾		1	kV
		Charged device model (CDM), per JEDEC specification JESD22-C101, all pins ⁽²⁾		250	V

(1) JEDEC document JEP155 states that 500-V HBM allows safe manufacturing with a standard ESD control process.

(2) JEDEC document JEP157 states that 250-V CDM allows safe manufacturing with a standard ESD control process.

6.3 Recommended Operating Conditions

Over operating free-air temperature range (unless otherwise noted)

			MIN	TYP	MAX	UNIT
VIN	Input voltage	TPS92411P	7.5		94	V
		TPS92411	7.5		100	
T _J	Operating junction temperature		-40	25	150	°C

6.4 Thermal Information

THERMAL METRIC ⁽¹⁾		TPS92411		UNIT
		DBV	DDA	
		5 PINS	8 PINS	
θ _{JA}	Junction-to-ambient thermal resistance ⁽²⁾	209.8	58.6	°C/W
θ _{JCtop}	Junction-to-case (top) thermal resistance ⁽³⁾	125.2	72	
θ _{JB}	Junction-to-board thermal resistance ⁽⁴⁾	38	39.1	
ψ _{JT}	Junction-to-top characterization parameter ⁽⁵⁾	15.6	21.6	
ψ _{JB}	Junction-to-board characterization parameter ⁽⁶⁾	37.1	39.1	
θ _{JCbot}	Junction-to-case (bottom) thermal resistance ⁽⁷⁾	N/A	15	

- (1) For more information about traditional and new thermal metrics, see the IC Package Thermal Metrics application report, [SPRA953](#).
- (2) The junction-to-ambient thermal resistance under natural convection is obtained in a simulation on a JEDEC-standard, high-K board, as specified in JESD51-7, in an environment described in JESD51-2a.
- (3) The junction-to-case (top) thermal resistance is obtained by simulating a cold plate test on the package top. No specified JEDEC-standard test exists, but a close description can be found in the ANSI SEMI standard G30-88.
- (4) The junction-to-board thermal resistance is obtained by simulating in an environment with a ring cold plate fixture to control the PCB temperature, as described in JESD51-8.
- (5) The junction-to-top characterization parameter, θ_{JT}, estimates the junction temperature of a device in a real system and is extracted from the simulation data for obtaining θ_{JA}, using a procedure described in JESD51-2a (sections 6 and 7).
- (6) The junction-to-board characterization parameter, θ_{JB}, estimates the junction temperature of a device in a real system and is extracted from the simulation data for obtaining θ_{JA}, using a procedure described in JESD51-2a (sections 6 and 7).
- (7) The junction-to-case (bottom) thermal resistance is obtained by simulating a cold plate test on the exposed (power) pad. No specific JEDEC standard test exists, but a close description can be found in the ANSI SEMI standard G30-88.

6.5 Electrical Characteristics

 Unless otherwise specified $-40\text{ °C} \leq T_J = T_A \leq 150\text{ °C}$, $(V_{VIN} - V_{VS}) = 30\text{ V}$, $R_{RSET} = R_{RSNS} = \text{Open}$, all voltages are with respect to VS.

PARAMETER		TEST CONDITIONS	MIN	TYP	MAX	UNIT
INPUT SUPPLY (VIN)						
V _{IN(ovp)}	Input overvoltage protection	TPS92411P	Rising threshold	95	100	V
			Falling threshold		96	
			Hysteresis		4	
I _Q	Bias current			200	400	μA
V _{IN(uvlo)}	Input undervoltage lockout		Rising threshold	6.5	7	V
V _{IN(hys)}	Input UVLO hysteresis			370		mV
SWITCH CONTROL (RSNS, RSET)						
I _{RSNS}	RSNS threshold current		-3.3	-4	-4.9	μA
V _{RSNS_OS}	RSNS offset voltage		165	210	255	mV
V _{RSET}	RSET threshold voltage		1.2	1.25	1.3	V
I _{RSET}	RSET current	I _{RSNS} = -20 μA, (V _{RSET} - V _{VS}) = 1.5 V	-9.3	-10	-10.7	μA
		I _{RSNS} = -40 μA, (V _{RSET} - V _{VS}) = 1.5 V	-19	-20	-21	
		I _{RSNS} = -100 μA, (V _{RSET} - V _{VS}) = 1.5 V	-47.9	-50	-52.1	
SWITCH (DRAIN, VS)						
R _{DS(on)}	On-resistance	I _{DRAIN} = 100 mA, T _J = 25°C	1	2	2.5	Ω

Electrical Characteristics (接下页)

Unless otherwise specified $-40\text{ }^{\circ}\text{C} \leq T_J = T_A \leq 150\text{ }^{\circ}\text{C}$, $(V_{VIN} - V_{VS}) = 30\text{ V}$, $R_{RSET} = R_{RSNS} = \text{Open}$, all voltages are with respect to VS.

PARAMETER		TEST CONDITIONS	MIN	TYP	MAX	UNIT
$dv/dt_{(ON)}$	Switch ON slew rate	$(V_{DRAIN} - V_{VS})$ falling 36 V to 4 V, $I_{SW} = 100\text{ mA}$		1		V/ μ s
$dv/dt_{(OFF)}$	Switch OFF slew rate	$(V_{DRAIN} - V_{VS}) =$ rising 4 V to 36 V, $I_{SW} = 100\text{ mA}$		0.5		

6.6 Typical Characteristics

Unless otherwise stated, $-40\text{ }^{\circ}\text{C} \leq T_A = T_J \leq 150\text{ }^{\circ}\text{C}$, $(V_{VIN} - V_{VS}) = 30\text{ V}$, all voltages are with respect to VS.

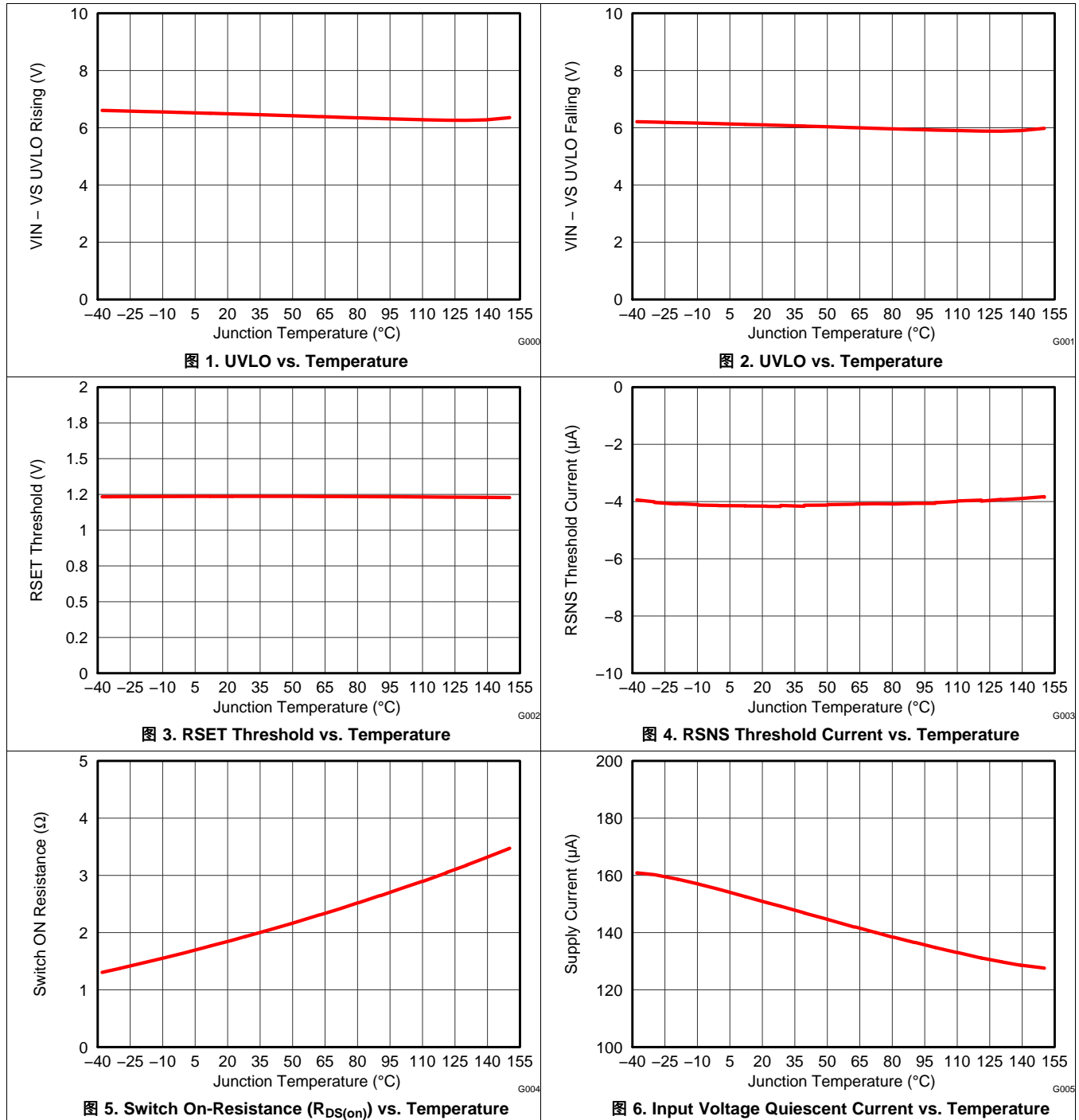

Typical Characteristics (接下页)

Unless otherwise stated, $-40\text{ }^{\circ}\text{C} \leq T_A = T_J \leq 150\text{ }^{\circ}\text{C}$, $(V_{VIN} - V_{VS}) = 30\text{ V}$, all voltages are with respect to VS.

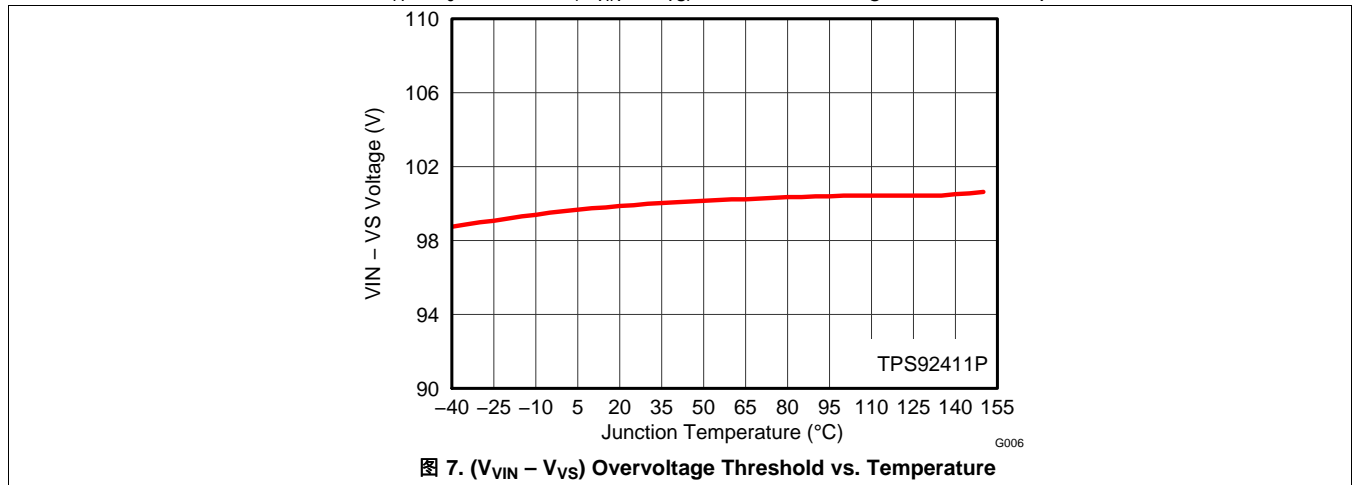

7 Detailed Description

7.1 Overview

The TPS92411 is an advanced, floating driver specifically designed for use with a linear regulator in low-power offline LED lighting applications. It integrates an on-board 100-V MOSFET switch to shunt LED current as the line transitions. As the line transitions through the cycle, the device monitors critical nodes for zero cross at which time the internal switch is either opened or shorted to steer the current through or away from the LED stack. The TPS92411 does not directly control output power or LED current, it just directs current to the LED stack or bypasses the LED stack.

7.2 Functional Block Diagram



图 8. TPS92411 Block Diagram

Functional Block Diagram (接下页)

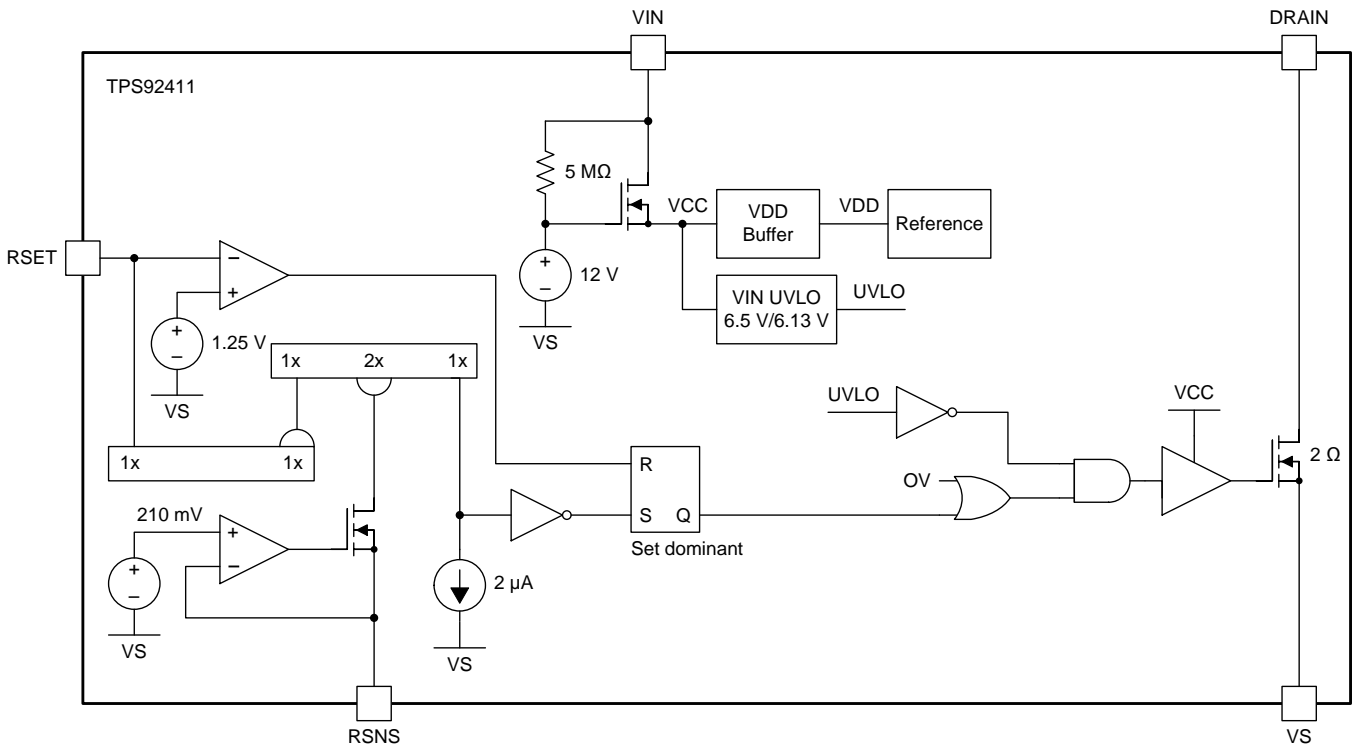

图 9. TPS92411P Block Diagram

7.3 Feature Description

7.3.1 Overvoltage Protection (OVP)

Overvoltage protection (OVP) in the TPS92411P version protects the device as well as the LEDs and storage capacitor. The OVP is set at approximately 100 V ($V_{VIN} - V_{VS}$) and closes the internal switch when the threshold voltage is reached. For this reason LED stack voltages of 94 V or less are recommended. Higher voltages can be used with the TPS92411 version but tolerances must be considered to ensure that the 105 V absolute maximum rating is not exceeded.

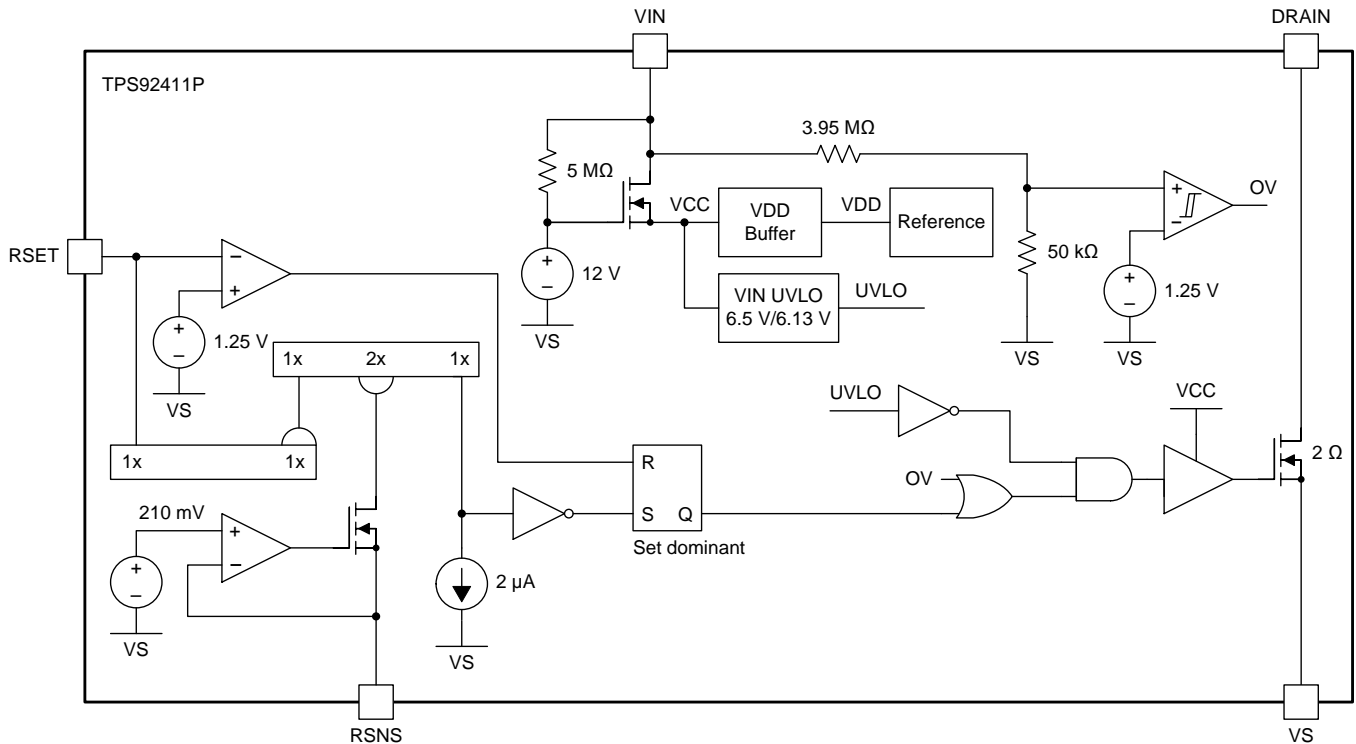
7.3.2 Input Undervoltage Lockout (UVLO)

The TPS92411 includes input UVLO. The UVLO prevents the device from operation until the VIN pin voltage with respect to VS exceeds 6.5 V and ensures the device behaves properly when enabled.

7.3.3 LED Capacitor

A capacitor is required across each LED stack to provide current to the LEDs during the switch ON time. Refer to the available calculator software (SLVC516 for 120-V applications or SLVC517 for 230-V applications) for calculating the minimum value required for any particular application. The software calculates the minimum value required for a particular application, but best performance is achieved by using as much capacitance as possible given size and cost constraints. These design tools also calculate a minimum value for any given current ripple percent or flicker index desired for the particular application.

7.3.4 Blocking Diode

A blocking diode is required between the drain of the switch (DRAIN) and the anode of the LED stack. This prevents the LED capacitor from discharging through the switch during the switch ON time instead allowing it to discharge through the LED stack. This diode should be rated for 200 V reverse voltage and capable of forward currents as high as the average linear regulator current setting.

7.4 Device Functional Modes

The TPS92411P has 4 functional modes while the TPS92411 has 3:

7.4.1 Input UVLO

As described in the previous section the device and internal switch will remain off until VIN is 6.5V or greater with respect to VS.

7.4.2 Operating with Internal Switch ON

After the device crosses the UVLO threshold the internal switch will turn on and remain on until the voltage at the VIN pin exceeds the threshold voltage set by the RSET resistor.

7.4.3 Operating with Internal Switch OFF

When the RSET threshold voltage is exceeded on the VIN pin the internal switch will turn off forcing all the current to flow through the LEDs and charge the LED capacitor. The switch will remain off until the VS pin drops below the threshold voltage set by RSNS or an overvoltage event occurs (TPS92411P only).

7.4.4 Overvoltage Operation (TPS92411P)

If an LED fails open or a string voltage exceeding the OVP level is used the device will enter OVP operation. The internal switch will close and remain closed until the VIN voltage with respect to the VS pin drops low enough to engage normal operation again.

8 Application and Implementation

8.1 Application Information

The TPS92411 is an advanced, floating driver specifically designed for use with a linear regulator in low-power offline LED lighting applications. It integrates an on-board 100-V MOSFET switch to shunt LED current as the line transitions. As the line transitions through the cycle, the device monitors critical nodes for zero cross at which time the internal switch is either opened or shorted to steer the current through or away from the LED stack. Use the following design procedure to select components for the TPS92411. The following calculators may also be used to select components for the TPS92411:

- [SLVC579](#) for 120-V applications using the TPS92410
- [SLVC580](#) for 230-V applications using the TPS92410
- [SLVC516](#) for 120-V applications using a discrete linear regulator
- [SLVC517](#) for 230-V applications using a discrete linear regulator

PSpice and TINA-TI models are also available. The following are typical applications using the TPS92411 for both 120-V and 230-V applications using a discrete linear regulator.

8.2 Typical Application

8.2.1 120-VAC, Phase Dimmable 11.5-W Input with Discrete Linear Regulator



图 10. 120-VAC, Phase Dimmable 11.5-W Input with Discrete Linear Regulator

8.2.1.1 Design Requirements

For the 120-V application shown in [图 10](#) the highest efficiency is obtained by using a high-voltage total LED stack to reduce losses in the linear regulator FET. The best current sharing efficiency between stacks can be achieved by using the lowest voltage stack at the bottom and making each stack voltage above 2 times the voltage of the stack below it. In this example 20-V LEDs are used. This effectively gives the lowest stack a total of 20 V, the middle stack a total of 40 V, and the upper stack a total of 80 V. The RSNS resistor is used to set a

Typical Application (接下页)

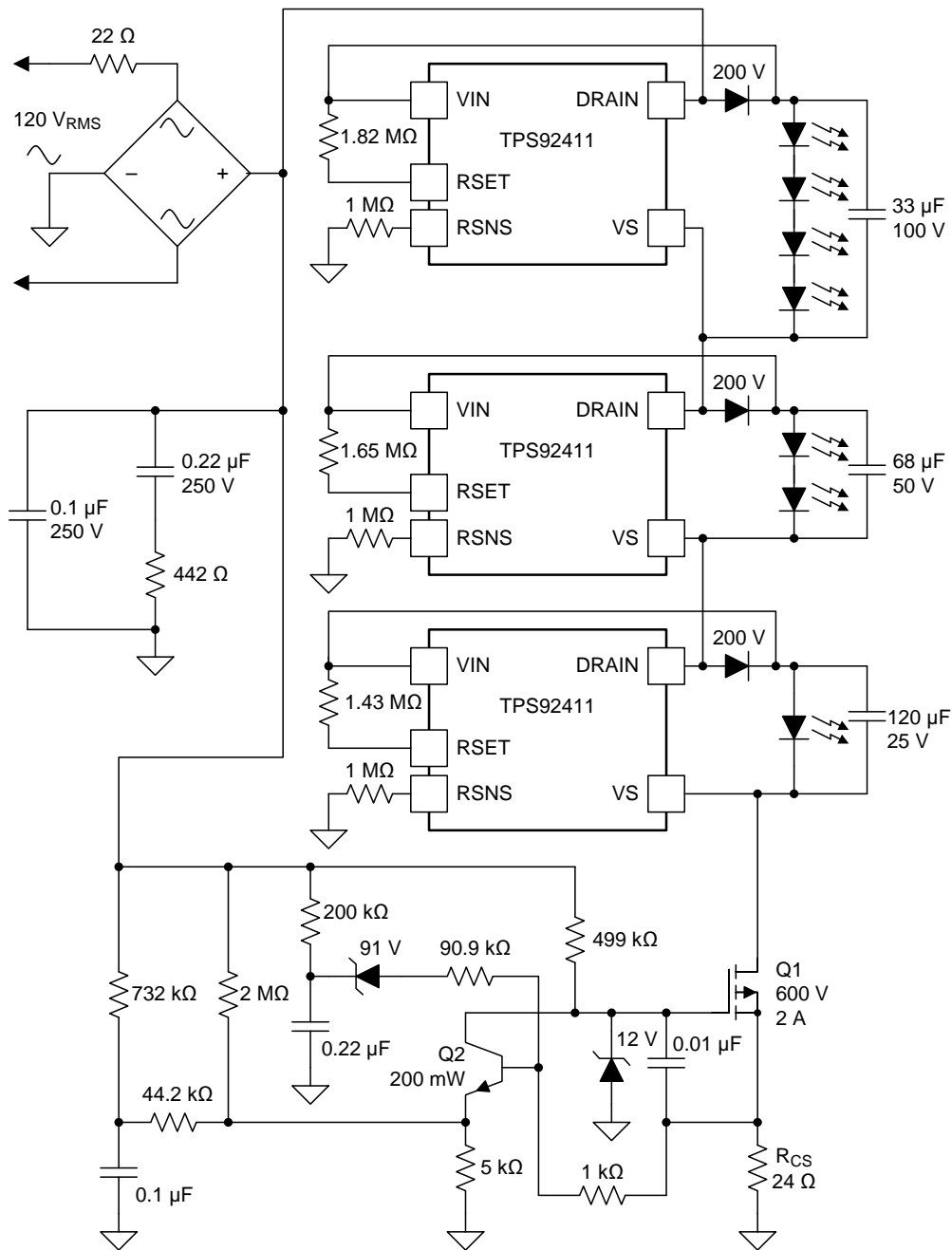
low voltage point so that when the VS pin voltage falls below this threshold (either from the AC line falling or a higher voltage stack switch above it turning OFF) the TPS92411 switch turns ON and bypasses the LEDs. During the ON-time, the LEDs are supplied current from the capacitor. The RSET voltage is used to set a threshold to detect when the input voltage crosses this threshold it turns OFF the switch and allows the LEDs to conduct current from the line and charge the bypass capacitor.

8.2.1.2 Detailed Design Procedure

- Set V_{RSNS} for all three TPS92411 devices at 4 V
- Set V_{RSET} for the bottom stack at 26 V (20 V stack plus 6 V headroom)
- Set V_{RSET} for the middle stack at 46 V (40 V stack plus 6 V headroom)
- Set V_{RSET} for the top stack at 86 V (80 V stack plus 6 V headroom)

Switching order as the rectified AC line voltage increases is shown in 表 1. 图 11 illustrates when each switch turns ON or OFF.

8.2.1.2.1 Setting the Switching Thresholds (RSNS, RSET)

The TPS92411 features two threshold settings to allow for proper LED control. The first setting determines when the internal switch turns off and allows current to charge the capacitor and flow through the LEDs. The second setting determines when the switch turns on to shunt the LEDs and allow the capacitor to supply current. The lower switch turn-on threshold (V_{SNS}) should be set first using a resistor (R_{RSNS}) from the RSNS pin to system ground. For best efficiency set this threshold between 4 V and 6 V. Then the upper switch turn-off threshold (V_{VS}) can be set using a resistor (R_{RSET}) from the RSET pin to the VIN pin. Set this threshold approximately 6 V to 10 V above the LED stack voltage (V_{LED}). The RSET threshold should be greater than the LED stack voltage plus the value of the RSNS threshold to prevent errant switching. These thresholds can be set with resistance calculated using 公式 1 and 公式 2.

$$R_{RSNS} = \frac{V_{SNS} + 0.21V}{|I_{RSNS}|} \quad (1)$$

$$R_{RSET} = \frac{(V_{LED} - 1.24V) \times 2 \times R_{RSNS}}{V_{VS} + 0.21V} \quad (2)$$

表 1. Switching Order on Rising Edge of Rectified 120-VAC ⁽¹⁾⁽²⁾

STACK		
TOP 80-V	MIDDLE 40-V	BOTTOM 20-V
0	0	0
0	0	1
0	1	0
0	1	1
1	0	0
1	0	1
1	1	0
1	1	1

(1) 0 denotes switch ON and LEDs bypassed and supplied by the capacitor.

(2) 1 denotes switch OFF and LEDs conducting from the line, capacitor charging up.



图 11. Switching Order on Rectified 120-VAC Waveform

The linear regulator in 图 11 generates a current sense RMS voltage of approximately 2.3 V. The linear regulator RMS current is equal to the input current drawn from the AC line. For example, for a 11.5-W input power system the input current should be approximately 0.095 A and a 24-Ω resistor should be chosen for RCS. Other input power levels (P_{IN}) can be obtained using 公式 3.

$$R_{CS} = \frac{120 V_{RMS} \times 2.3 V_{RMS}}{P_{IN}} \tag{3}$$

8.2.1.3 Application Curve

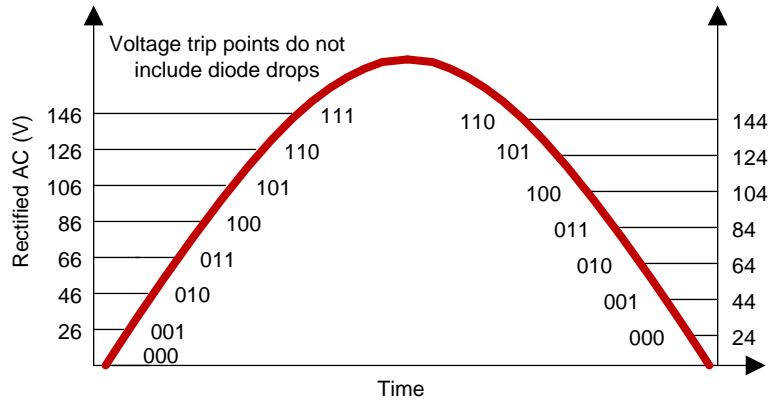

图 12. Power Factor vs. Input Voltage

below this threshold (either from the AC line falling or a higher voltage stack switch above it turning OFF) the TPS92411 switch turns ON and bypasses the LEDs. During the ON-time, the capacitor supplies current to the LEDs. The RSET voltage threshold for a 230-V application is generally set to approximately 8 V to 12 V above the LED stack voltage connected across the TPS92411 (for an RSNS voltage of 6 V). This threshold is higher than in the typical 120-V application to allow more headroom.

8.2.2.2 Detailed Design Procedure

- Set V_{RSNS} for all three TPS92411 devices at 6 V
- Set V_{RSET} for the bottom stack at 49 V (40 V stack plus 9 V headroom)
- Set V_{RSET} for the middle stack at 89 V (80 V stack plus 9 V headroom)
- Set V_{RSET} for the top stack at 169 V (160 V stack plus 9 V headroom)

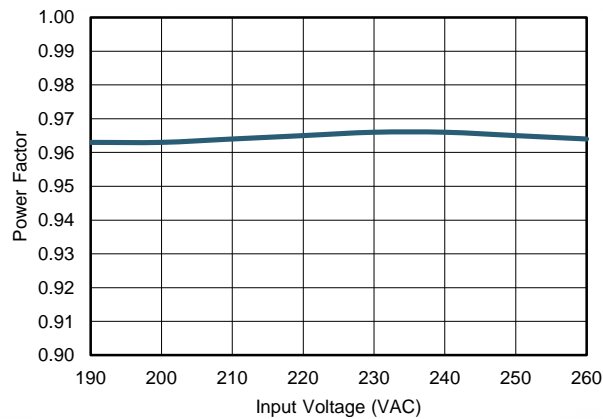
Switching order as the rectified AC line voltage increases is shown in 表 2. 图 14 illustrates when each switch turns ON or OFF.

表 2. Switching Order on Rising Edge of the Rectified 230-VAC Waveform⁽¹⁾⁽²⁾

STACK		
TOP 160-V	MIDDLE 80-V	BOTTOM 40-V
0	0	0
0	0	1
0	1	0
0	1	1
1	0	0
1	0	1
1	1	0
1	1	1

(1) 0 denotes switch ON and LEDs bypassed and supplied by the capacitor.

(2) 1 denotes switch OFF and LEDs conducting from the line, capacitor charging up.



图 14. Switching Order on Rising Edge of the Rectified 230-VAC Waveform

The linear regulator in 图 14 generates a current sense RMS voltage of 2.44 V. The linear regulator RMS current is equal to the input current drawn from the AC line. For example, for a 16-W input power system the input current should be approximately 0.07 A and a 34.8-Ω resistor should be chosen for R_{CS} . Other input power levels (P_{IN}) can be calculated using 公式 4.

$$R_{CS} = \frac{230 V_{RMS} \times 2.44 V_{RMS}}{P_{IN}} \quad (4)$$

8.2.2.3 Application Curve

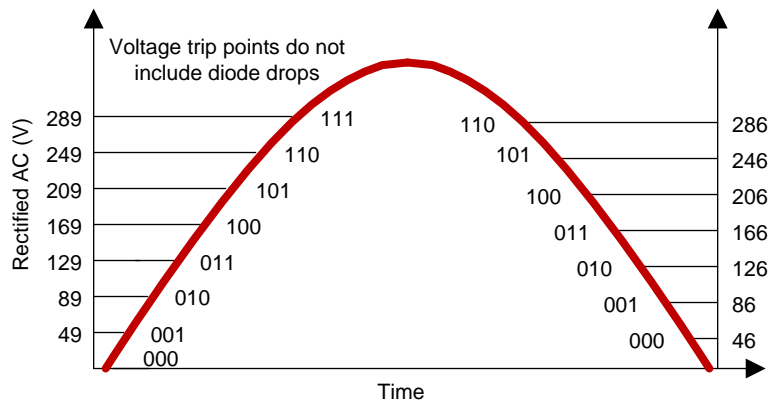

图 15. Power Factor Input Voltage

9 Power Supply Recommendations

For testing purposes any benchtop adjustable AC power supply with a power rating higher than what is required by the circuit is suitable. An example would be an Hewlett Packard 6811B or equivalent. An isolated supply is recommended for safety purposes.

10 Layout

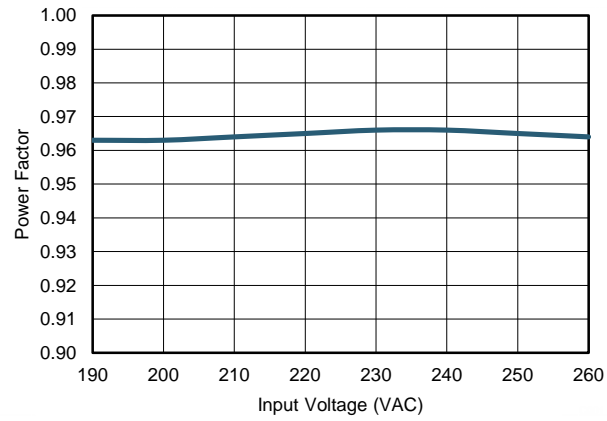
10.1 Layout Guidelines

The TPS92411 allows for a simple layout, however some considerations should be taken. The RSET resistor should be connected directly between the RSET pin and VIN pin as close to the device as possible. The trace between the resistor and the RSET pin should be as short as possible. The trace from the RSNS pin to the RSNS resistor should also be as short as possible to minimize parasitic capacitances. The blocking diode should be placed between the DRAIN pin and the VIN pin and also located close to the device. Placement of the LED capacitor may depend on the physical design of the application, however it should be placed as close to the TPS92411 as the design allows to minimize parasitic inductances.

10.2 Layout Example



图 16. Recommended Component Placement (DBV)



图 17. Recommended Component Placement (DDA)

11 器件和文档支持

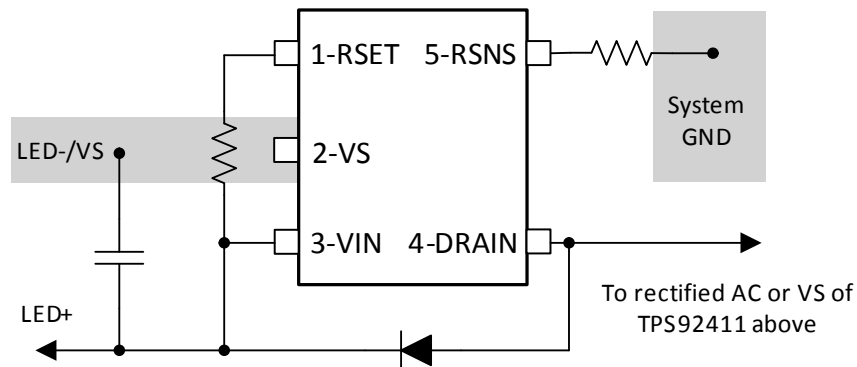
11.1 相关链接

以下表格列出了快速访问链接。范围包括技术文档、支持与社区资源、工具和软件，并且可以快速访问样片或购买链接。

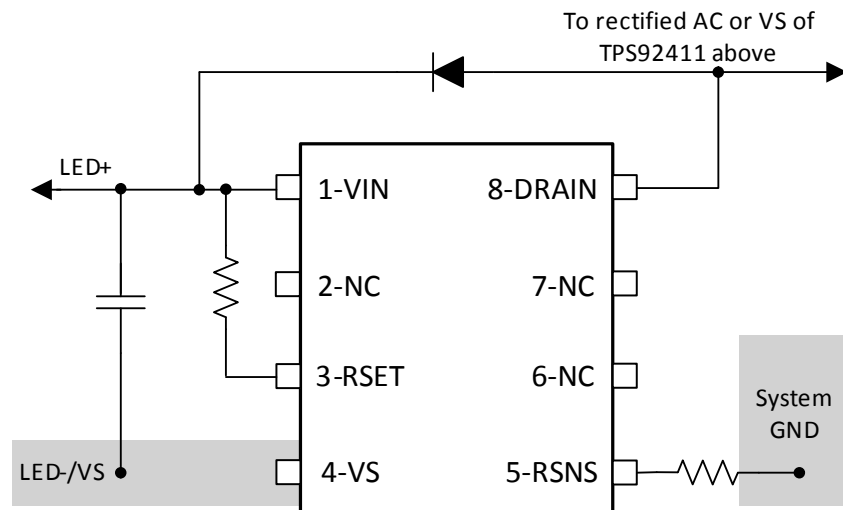
表 3. 相关链接

部件	产品文件夹	样片与购买	技术文档	工具与软件	支持与社区
TPS92411	请单击此处	请单击此处	请单击此处	请单击此处	请单击此处
TPS92411P	请单击此处	请单击此处	请单击此处	请单击此处	请单击此处

11.2 商标

All trademarks are the property of their respective owners.

11.3 静电放电警告



这些装置包含有限的内置 ESD 保护。存储或装卸时，应将导线一起截短或将装置放置于导电泡棉中，以防止 MOS 门极遭受静电损伤。

11.4 术语表

[SLYZ022](#) — TI 术语表。

这份术语表列出并解释术语、首字母缩略词和定义。

12 机械封装和可订购信息

以下页中包括机械封装和可订购信息。这些信息是针对指定器件可提供的最新数据。这些数据会在无通知且不对本文档进行修订的情况下发生改变。欲获得该数据表的浏览器版本，请查阅左侧的导航栏。

PACKAGING INFORMATION

Orderable Device	Status (1)	Package Type	Package Drawing	Pins	Package Qty	Eco Plan (2)	Lead finish/ Ball material (6)	MSL Peak Temp (3)	Op Temp (°C)	Device Marking (4/5)	Samples
TPS92411DBVR	ACTIVE	SOT-23	DBV	5	3000	RoHS & Green	NIPDAU	Level-1-260C-UNLIM	-40 to 150	PB9Q	Samples
TPS92411DBVT	ACTIVE	SOT-23	DBV	5	250	RoHS & Green	NIPDAU	Level-1-260C-UNLIM	-40 to 150	PB9Q	Samples
TPS92411DDA	ACTIVE	SO PowerPAD	DDA	8	75	RoHS & Green	NIPDAUAG	Level-2-260C-1 YEAR	-40 to 150	92411	Samples
TPS92411DDAR	ACTIVE	SO PowerPAD	DDA	8	2500	RoHS & Green	NIPDAUAG	Level-2-260C-1 YEAR	-40 to 150	92411	Samples
TPS92411PDBVR	ACTIVE	SOT-23	DBV	5	3000	RoHS & Green	NIPDAU	Level-1-260C-UNLIM	-40 to 150	PB8Q	Samples
TPS92411PDBVT	ACTIVE	SOT-23	DBV	5	250	RoHS & Green	NIPDAU	Level-1-260C-UNLIM	-40 to 150	PB8Q	Samples
TPS92411PDDA	ACTIVE	SO PowerPAD	DDA	8	75	RoHS & Green	NIPDAUAG	Level-2-260C-1 YEAR	-40 to 150	92411P	Samples
TPS92411PDDAR	ACTIVE	SO PowerPAD	DDA	8	2500	RoHS & Green	NIPDAUAG	Level-2-260C-1 YEAR	-40 to 150	92411P	Samples

(1) The marketing status values are defined as follows:

ACTIVE: Product device recommended for new designs.

LIFEBUY: TI has announced that the device will be discontinued, and a lifetime-buy period is in effect.

NRND: Not recommended for new designs. Device is in production to support existing customers, but TI does not recommend using this part in a new design.

PREVIEW: Device has been announced but is not in production. Samples may or may not be available.

OBSOLETE: TI has discontinued the production of the device.

(2) **RoHS:** TI defines "RoHS" to mean semiconductor products that are compliant with the current EU RoHS requirements for all 10 RoHS substances, including the requirement that RoHS substance do not exceed 0.1% by weight in homogeneous materials. Where designed to be soldered at high temperatures, "RoHS" products are suitable for use in specified lead-free processes. TI may reference these types of products as "Pb-Free".

RoHS Exempt: TI defines "RoHS Exempt" to mean products that contain lead but are compliant with EU RoHS pursuant to a specific EU RoHS exemption.

Green: TI defines "Green" to mean the content of Chlorine (Cl) and Bromine (Br) based flame retardants meet JS709B low halogen requirements of <=1000ppm threshold. Antimony trioxide based flame retardants must also meet the <=1000ppm threshold requirement.

(3) MSL, Peak Temp. - The Moisture Sensitivity Level rating according to the JEDEC industry standard classifications, and peak solder temperature.

(4) There may be additional marking, which relates to the logo, the lot trace code information, or the environmental category on the device.

(5) Multiple Device Markings will be inside parentheses. Only one Device Marking contained in parentheses and separated by a "~" will appear on a device. If a line is indented then it is a continuation of the previous line and the two combined represent the entire Device Marking for that device.

⁽⁶⁾ Lead finish/Ball material - Orderable Devices may have multiple material finish options. Finish options are separated by a vertical ruled line. Lead finish/Ball material values may wrap to two lines if the finish value exceeds the maximum column width.

Important Information and Disclaimer: The information provided on this page represents TI's knowledge and belief as of the date that it is provided. TI bases its knowledge and belief on information provided by third parties, and makes no representation or warranty as to the accuracy of such information. Efforts are underway to better integrate information from third parties. TI has taken and continues to take reasonable steps to provide representative and accurate information but may not have conducted destructive testing or chemical analysis on incoming materials and chemicals. TI and TI suppliers consider certain information to be proprietary, and thus CAS numbers and other limited information may not be available for release.

In no event shall TI's liability arising out of such information exceed the total purchase price of the TI part(s) at issue in this document sold by TI to Customer on an annual basis.

TAPE AND REEL INFORMATION

QUADRANT ASSIGNMENTS FOR PIN 1 ORIENTATION IN TAPE

*All dimensions are nominal

Device	Package Type	Package Drawing	Pins	SPQ	Reel Diameter (mm)	Reel Width W1 (mm)	A0 (mm)	B0 (mm)	K0 (mm)	P1 (mm)	W (mm)	Pin1 Quadrant
TPS92411DBVR	SOT-23	DBV	5	3000	178.0	9.0	3.23	3.17	1.37	4.0	8.0	Q3
TPS92411DBVT	SOT-23	DBV	5	250	178.0	9.0	3.23	3.17	1.37	4.0	8.0	Q3
TPS92411DDAR	SO Power PAD	DDA	8	2500	330.0	12.8	6.4	5.2	2.1	8.0	12.0	Q1
TPS92411PDBVR	SOT-23	DBV	5	3000	178.0	9.0	3.23	3.17	1.37	4.0	8.0	Q3
TPS92411PDBVT	SOT-23	DBV	5	250	178.0	9.0	3.23	3.17	1.37	4.0	8.0	Q3
TPS92411PDDAR	SO Power PAD	DDA	8	2500	330.0	12.8	6.4	5.2	2.1	8.0	12.0	Q1

TAPE AND REEL BOX DIMENSIONS

*All dimensions are nominal

Device	Package Type	Package Drawing	Pins	SPQ	Length (mm)	Width (mm)	Height (mm)
TPS92411DBVR	SOT-23	DBV	5	3000	180.0	180.0	18.0
TPS92411DBVT	SOT-23	DBV	5	250	180.0	180.0	18.0
TPS92411DDAR	SO PowerPAD	DDA	8	2500	366.0	364.0	50.0
TPS92411PDBVR	SOT-23	DBV	5	3000	180.0	180.0	18.0
TPS92411PDBVT	SOT-23	DBV	5	250	180.0	180.0	18.0
TPS92411PDDAR	SO PowerPAD	DDA	8	2500	366.0	364.0	50.0

TUBE

*All dimensions are nominal

Device	Package Name	Package Type	Pins	SPQ	L (mm)	W (mm)	T (μm)	B (mm)
TPS92411DDA	DDA	HSOIC	8	75	517	7.87	635	4.25
TPS92411PDDA	DDA	HSOIC	8	75	517	7.87	635	4.25



DBV0005A

PACKAGE OUTLINE

SOT-23 - 1.45 mm max height

SMALL OUTLINE TRANSISTOR

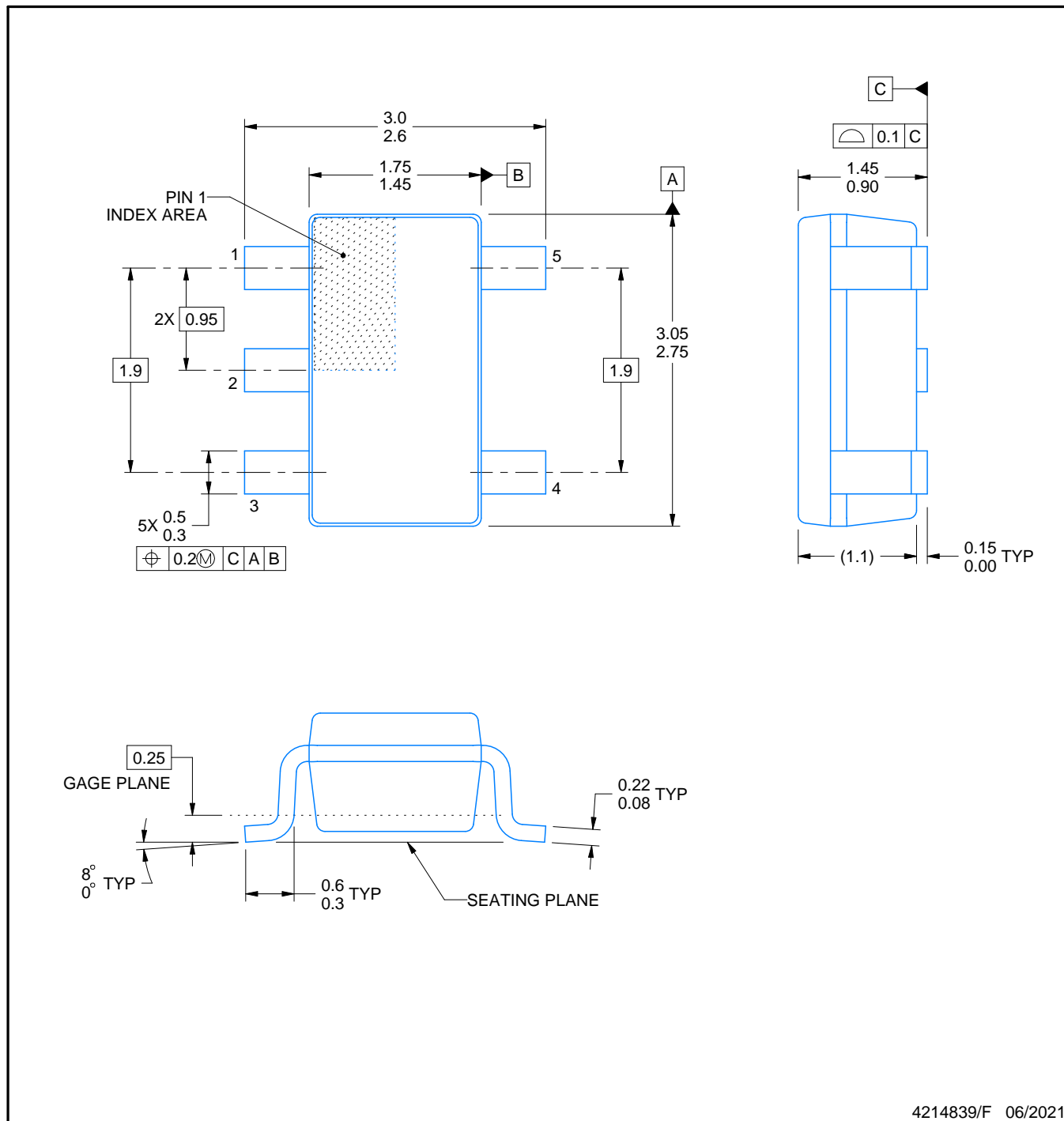

4214839/F 06/2021

NOTES:

1. All linear dimensions are in millimeters. Any dimensions in parenthesis are for reference only. Dimensioning and tolerancing per ASME Y14.5M.
2. This drawing is subject to change without notice.
3. Reference JEDEC MO-178.
4. Body dimensions do not include mold flash, protrusions, or gate burrs. Mold flash, protrusions, or gate burrs shall not exceed 0.25 mm per side.

EXAMPLE BOARD LAYOUT

DBV0005A

SOT-23 - 1.45 mm max height

SMALL OUTLINE TRANSISTOR



LAND PATTERN EXAMPLE
EXPOSED METAL SHOWN
SCALE:15X



SOLDER MASK DETAILS

4214839/F 06/2021

NOTES: (continued)

- 5. Publication IPC-7351 may have alternate designs.
- 6. Solder mask tolerances between and around signal pads can vary based on board fabrication site.

EXAMPLE STENCIL DESIGN

DBV0005A

SOT-23 - 1.45 mm max height

SMALL OUTLINE TRANSISTOR



SOLDER PASTE EXAMPLE
BASED ON 0.125 mm THICK STENCIL
SCALE:15X

4214839/F 06/2021

NOTES: (continued)

7. Laser cutting apertures with trapezoidal walls and rounded corners may offer better paste release. IPC-7525 may have alternate design recommendations.
8. Board assembly site may have different recommendations for stencil design.



Images above are just a representation of the package family, actual package may vary.
Refer to the product data sheet for package details.

DDA (R-PDSO-G8)

PowerPAD™ PLASTIC SMALL-OUTLINE



- NOTES:
- A. All linear dimensions are in millimeters. Dimensioning and tolerancing per ASME Y14.5-1994.
 - B. This drawing is subject to change without notice.
 - C. Body dimensions do not include mold flash or protrusion not to exceed 0,15.
 - D. This package is designed to be soldered to a thermal pad on the board. Refer to Technical Brief, PowerPad Thermally Enhanced Package, Texas Instruments Literature No. SLMA002 for information regarding recommended board layout. This document is available at www.ti.com <<http://www.ti.com>>.
 - E. See the additional figure in the Product Data Sheet for details regarding the exposed thermal pad features and dimensions.
 - F. This package complies to JEDEC MS-012 variation BA

PowerPAD is a trademark of Texas Instruments.

DDA (R-PDSO-G8)

PowerPAD™ PLASTIC SMALL OUTLINE

THERMAL INFORMATION

This PowerPAD™ package incorporates an exposed thermal pad that is designed to be attached to a printed circuit board (PCB). The thermal pad must be soldered directly to the PCB. After soldering, the PCB can be used as a heatsink. In addition, through the use of thermal vias, the thermal pad can be attached directly to the appropriate copper plane shown in the electrical schematic for the device, or alternatively, can be attached to a special heatsink structure designed into the PCB. This design optimizes the heat transfer from the integrated circuit (IC).

For additional information on the PowerPAD package and how to take advantage of its heat dissipating abilities, refer to Technical Brief, PowerPAD Thermally Enhanced Package, Texas Instruments Literature No. SLMA002 and Application Brief, PowerPAD Made Easy, Texas Instruments Literature No. SLMA004. Both documents are available at www.ti.com.

The exposed thermal pad dimensions for this package are shown in the following illustration.



Exposed Thermal Pad Dimensions

4206322-6/L 05/12

NOTE: A. All linear dimensions are in millimeters

PowerPAD is a trademark of Texas Instruments



- NOTES:
- A. All linear dimensions are in millimeters.
 - B. This drawing is subject to change without notice.
 - C. Publication IPC-7351 is recommended for alternate designs.
 - D. This package is designed to be soldered to a thermal pad on the board. Refer to Technical Brief, PowerPad Thermally Enhanced Package, Texas Instruments Literature No. SLMA002, SLMA004, and also the Product Data Sheets for specific thermal information, via requirements, and recommended board layout. These documents are available at www.ti.com <<http://www.ti.com>>. Publication IPC-7351 is recommended for alternate designs.
 - E. Laser cutting apertures with trapezoidal walls and also rounding corners will offer better paste release. Customers should contact their board assembly site for stencil design recommendations. Example stencil design based on a 50% volumetric metal load solder paste. Refer to IPC-7525 for other stencil recommendations.
 - F. Customers should contact their board fabrication site for solder mask tolerances between and around signal pads.

PowerPAD is a trademark of Texas Instruments.

重要声明和免责声明

TI“按原样”提供技术和可靠性数据（包括数据表）、设计资源（包括参考设计）、应用或其他设计建议、网络工具、安全信息和其他资源，不保证没有瑕疵且不做任何明示或暗示的担保，包括但不限于对适销性、某特定用途方面的适用性或不侵犯任何第三方知识产权的暗示担保。

这些资源可供使用 TI 产品进行设计的熟练开发人员使用。您将自行承担以下全部责任：(1) 针对您的应用选择合适的 TI 产品，(2) 设计、验证并测试您的应用，(3) 确保您的应用满足相应标准以及任何其他功能安全、信息安全、监管或其他要求。

这些资源如有变更，恕不另行通知。TI 授权您仅可将这些资源用于研发本资源所述的 TI 产品的应用。严禁对这些资源进行其他复制或展示。您无权使用任何其他 TI 知识产权或任何第三方知识产权。您应全额赔偿因在这些资源的使用中对 TI 及其代表造成的任何索赔、损害、成本、损失和债务，TI 对此概不负责。

TI 提供的产品受 [TI 的销售条款](#) 或 [ti.com](#) 上其他适用条款/TI 产品随附的其他适用条款的约束。TI 提供这些资源并不会扩展或以其他方式更改 TI 针对 TI 产品发布的适用的担保或担保免责声明。

TI 反对并拒绝您可能提出的任何其他或不同的条款。

邮寄地址：Texas Instruments, Post Office Box 655303, Dallas, Texas 75265

Copyright © 2022，德州仪器 (TI) 公司

X-ON Electronics

Largest Supplier of Electrical and Electronic Components

Click to view similar products for [LED Lighting Drivers](#) category:

Click to view products by [Texas Instruments](#) manufacturer:

Other Similar products are found below :

[LV5235V-MPB-H](#) [AP5726WUG-7](#) [IS31BL3228B-UTLS2-TR](#) [IS31BL3506B-TTLS2-TR](#) [AP5725FDCG-7](#) [AP5726FDCG-7](#) [SLG7NT4082V](#)
[SLG7NT4082VTR](#) [AP5725WUG-7](#) [BD1604MVV-E2](#) [MAX16840ATB+](#) [CAT4004BHU2-GT3](#) [TLE4242EJ](#) [IS31LT3172-GRLS4-TR](#)
[IS32LT3174-GRLA3-TR](#) [ZXLD1374QESTTC](#) [NCV78825DQ0R2G](#) [MP4425AGQB-P](#) [MP3367GR-P](#) [MPQ3369GR-P](#) [MPQ7220GF-AEC1-P](#)
[MP3362GJ-Z](#) [DIO5662ST6](#) [IS31BL3508A-TTLS2-TR](#) [DIO5661TST6](#) [NJW4617DL3-TE1](#) [BD2802GU-E2](#) [BD6583MUV-E2](#)
[NCV7693DB0R2G](#) [LV52207NXA-VH](#) [NCL30076AADR2G](#) [NCL30486B2DR2G](#) [NCL30488B4DR2G](#) [NCV78763MW4AR2G](#)
[BD18353EFV-ME2](#) [A6217KLJTR-T](#) [LT3761EMSE#TRPBF](#) [TLD2132-1EP](#) [TLD2331-3EP](#) [MPM6010GQV-AEC1-Z](#) [MPQ4425MGQB-](#)
[AEC1-Z](#) [MPQ3326GR-AEC1-Z](#) [MPQ7230GLE-AEC1-Z](#) [MP2341GTL-Z](#) [BCR602](#) [IS31FL3236-TQLS2-TR](#) [TLD700216ESXUMA1](#)
[LM3405AXMYX/NOPB](#) [LM36273YFFR](#) [MP46885DN-LF-Z](#)