

# TPSM8A28、TPSM8A29 具有差分遥感功能的 2.7V 至 16V 输入、12A、15A 降压电源模块

## 1 特性

- TPSM8A28：输入电压范围为 3V 至 16V，电流高达 12A
- TPSM8A29：输入电压范围为 4V 至 16V，电流高达 15A
- 输入范围为 2.7V 至 16V 时，外部偏压范围为 4.75 V 至 5.3 V
- 输出电压范围：0.6V 至 5.5V
- 集成 MOSFET、电感器和基本无源器件
- 在 D-CAP3™ 控制模式下可提供快速负载阶跃响应
- 支持所有陶瓷输出电容器
- 0.6V 基准电压，±1% 容差（在 -40°C 至 +125°C 的结温范围内）
- 可选 FCCM 或自动跳跃 Eco-mode™ 可实现较高的轻负载效率
- 通过 R<sub>TRIP</sub> 实现可编程电流限制
- 引脚可选开关频率：600kHz、800kHz、1MHz
- 可实现高输出精度的差分遥感功能
- 可编程软启动时间
- 外部基准输入，用于跟踪
- 预偏置启动功能
- 开漏电源正常状态输出
- 在发生 OC 和 UV 故障时进入断续模式，在发生 OV 故障时进入闭锁模式
- 6.5mm × 7.5mm × 4.0mm，RDG 封装
- 完全符合 RoHS 标准，无需豁免

## 2 应用

- 数据中心交换机
- 核心路由器
- 单板计算机
- 光学模块

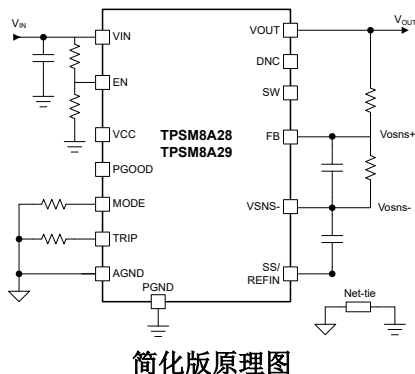

## 3 说明

TPSM8A28 和 TPSM8A29 降压电源模块具有小尺寸和高效。此模块系列包含集成电感器和基本无源器件，不需要外部补偿，可更大程度地减小解决方案尺寸。

特性包括差分遥感功能、高性能集成 MOSFET、高精度 0.6V 电压基准、D-CAP3™ 控制模式、可选跳跃模式和可编程软启动。

TPSM8A28 和 TPSM8A29 无铅、完全符合 RoHS 标准，无需豁免。

### 器件信息

器件型号	封装 <sup>(1)</sup>	封装尺寸 (标称值)
TPSM8A28	B3QFN-RDG	6.5mm × 7.5mm
TPSM8A29	B3QFN-RDG	6.5mm × 7.5mm

(1) 如需了解所有可用封装，请参阅数据表末尾的可订购产品附录。

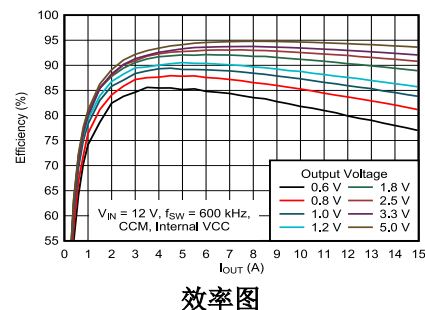

## Table of Contents

<b>1 特性</b> .....	1	8.1 Application Information.....	22
<b>2 应用</b> .....	1	8.2 Typical Application.....	22
<b>3 说明</b> .....	1	<b>9 Power Supply Recommendations</b> .....	33
<b>4 Revision History</b> .....	2	<b>10 Layout</b> .....	34
<b>5 Pin Configuration and Functions</b> .....	3	10.1 Layout Guidelines.....	34
<b>6 Specifications</b> .....	4	10.2 Layout Example.....	34
6.1 Absolute Maximum Ratings.....	4	10.3 EMI.....	35
6.2 ESD Ratings.....	4	<b>11 Device and Documentation Support</b> .....	37
6.3 Recommended Operating Conditions.....	4	11.1 Device Support.....	37
6.4 Thermal Information.....	5	11.2 Documentation Support.....	37
6.5 Electrical Characteristics.....	5	11.3 接收文档更新通知.....	37
6.6 Typical Characteristics.....	8	11.4 支持资源.....	37
<b>7 Detailed Description</b> .....	9	11.5 Trademarks.....	37
7.1 Overview.....	9	11.6 Electrostatic Discharge Caution.....	37
7.2 Functional Block Diagram.....	9	11.7 术语表.....	37
7.3 Feature Description.....	10	<b>12 Mechanical, Packaging, and Orderable Information</b> .....	38
7.4 Device Functional Modes.....	18		
<b>8 Application and Implementation</b> .....	22		

## 4 Revision History

注：以前版本的页码可能与当前版本的页码不同

Changes from Revision * (August 2021) to Revision A (November 2021)	Page
• 将 TPSM8A29 从“预告信息”更改为“量产数据”并添加了 TPSM8A28.....	1

## 5 Pin Configuration and Functions



图 5-1. 25-Pin B3QFN RDG Package (Top View)



图 5-2. 25-Pin B3QFN RDG Package (Bottom View)

表 5-1. Pin Functions

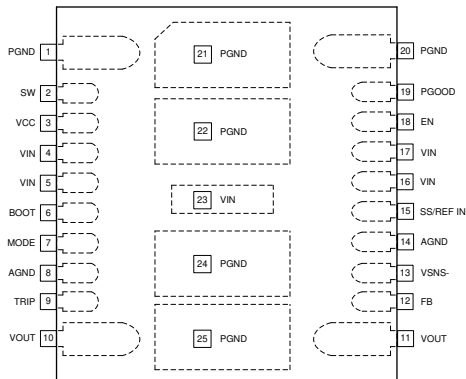
PIN		TYPE <sup>(1)</sup>	DESCRIPTION
NAME	NO.		
PGND	1, 20, 21, 22, 24, 25	G	Power ground of internal low-side MOSFET
SW	2	O	Output switching terminal of the power converter. No external connection needed. Do not connect.
VCC	3	I/O	Internal 4.5-V LDO output. Float or connect to an external power supply between 4.75 V and 5.3 V to save the power losses on the internal LDO. The voltage source on this pin powers both the internal circuitry and gate driver. A 1- $\mu$ F bypass capacitor is built in. No external bypass capacitors are required.
VIN	4, 5, 16, 17, 23	P	Power-supply input pins for the integrated power MOSFET pair and the internal LDO. Place the decoupling input capacitors from the VIN pins to PGND pins as close as possible.
BOOT	6	I/O	Supply rail for the high-side gate driver. A boot capacitor is integrated inside module. No external connection is needed. Do not connect.
MODE	7	I	The MODE pin sets Forced continuous-conduction mode (FCCM) or Skip-mode operation. It also selects the operating frequency by connecting a resistor from the MODE pin to AGND pin. $\pm 1\%$ tolerance resistor is recommended. See 表 7-1 for details.
AGND	8, 14	G	Ground pin. Reference point for the internal control circuits
TRIP	9	I/O	Current limit setting pin. Connect a resistor to AGND to set the current limit trip point. $\pm 1\%$ tolerance resistor is highly recommended. See 节 7.3.9 for details on the OCL setting.
VOUT	10, 11	O	These pins are connected to the output terminal of inductor. Connect these pins to output bypass capacitors.
FB	12	I	Output voltage feedback input. A resistor divider from the $V_{OUT}$ to VSNS - (tapped to FB pin) sets the output voltage.
VSNS -	13	I	The return connection for a remote voltage sensing configuration. It is also used as ground for the internal reference. Short to AGND for a single-end sense configuration.
SS/REFIN	15	I/O	Dual-function pin. Soft-start function: Connecting a capacitor to the VSNS - pin programs the soft-start time. Minimum soft-start time (1.5 ms) is fixed internally. REFIN function: The device always looks at the voltage on this SS/REFIN pin as the reference for the control loop. The internal reference voltage can be overridden by an external DC voltage source on this pin for tracking application.
EN	18	I	Enable pin. The enable pin turns the DC/DC switching converter on or off. Floating the EN pin before start-up disables the converter. The recommended operating condition for EN pin is maximum 5.5 V. Do not connect the EN pin to the VIN pin directly.
PGOOD	19	O	Open-drain power-good status signal. When the FB voltage moves outside the specified limits, PGOOD goes low after a 2- $\mu$ s delay.

(1) I = Input, O = Output, P = Supply, G = Ground

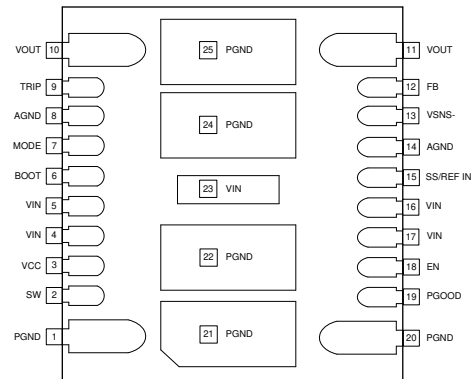
## 6 Specifications

### 6.1 Absolute Maximum Ratings

over operating free-air temperature range (unless otherwise noted)<sup>(1)</sup>

		MIN	MAX	UNIT	
Input voltage <sup>(2)</sup>	VIN	- 0.3	18	V	
	SW	DC	- 0.3		18
		Transient < 10 ns	- 3.0		22
		Transient < 2 ns	- 3.0		22
	BOOT	- 0.3	24		
	VSNS -	- 0.3	+0.3		
	TRIP, MODE, SS/REFIN, FB, EN	- 0.3	6		
Output voltage	PGOOD	- 0.3	6		
	VCC	- 0.3	6		
Mechanical shock	Mil-STD-883H, Method 2002.5, 1 msec, 1/2 sine, mounted		500	G	
Mechanical vibration	Mil-STD-883H, Method 2007.3, 20 to 2000 Hz		20	G	
Operating junction temperature, T <sub>J</sub>		- 40	125	°C	
Storage temperature, T <sub>stg</sub>		- 55	150	°C	

- (1) Operation outside the *Absolute Maximum Ratings* may cause permanent device damage. *Absolute Maximum Ratings* do not imply functional operation of the device at these or any other conditions beyond those listed under *Recommended Operating Conditions*. If used outside the *Recommended Operating Conditions* but within the *Absolute Maximum Ratings*, the device may not be fully functional, and this may affect device reliability, functionality, performance, and shorten the device lifetime.
- (2) All voltages are with respect to network ground terminal.

### 6.2 ESD Ratings

			VALUE	UNIT
V <sub>(ESD)</sub>	Electrostatic discharge	Human-body model (HBM), per ANSI/ESDA/JEDEC JS-001 <sup>(1)</sup>	±2000	V
		Charged-device model (CDM), per ANSI/ESDA/JEDEC JS-002 <sup>(2)</sup>	±500	

- (1) JEDEC document JEP155 states that 500-V HBM allows safe manufacturing with a standard ESD control process. Manufacturing with less than 500-V HBM is possible with the necessary precautions.
- (2) JEDEC document JEP157 states that 250-V CDM allows safe manufacturing with a standard ESD control process.

### 6.3 Recommended Operating Conditions

over operating free-air temperature range (unless otherwise noted)

		MIN	MAX	UNIT
Input voltage	VIN with valid external bias on VCC	2.7	16	V
	VIN with internal LDO, TPSM8A28	3.0	16	
	VIN with internal LDO, TPSM8A29	4.0	16	
	External reference to SS/REFIN	0.5	1.2	
	External bias range for VCC	4.75	5.3	
	VIN to enable the converter with internal LDO	3.3		
	TRIP, MODE, FB, EN	- 0.1	5.5	
	VSNS - (refer to AGND)	- 50	50	mV
Output voltage	PGOOD	- 0.1	5.5	V
	VCC	4.5	5.3	
Input current	PGOOD	0	10	mA
Junction temperature, T <sub>J</sub>	Operating junction temperature	- 40	125	°C

## 6.4 Thermal Information

THERMAL METRIC <sup>(1)</sup>		TPSM8A28 TPSM8A29		UNIT
		RDG (B3QFN)		
		25 PINS		
R <sub>θJA</sub>	Junction-to-ambient thermal resistance	21.6		°C/W
R <sub>θJC(top)</sub>	Junction-to-case (top) thermal resistance	7.5		°C/W
R <sub>θJB</sub>	Junction-to-board thermal resistance	13.0		°C/W

(1) For more information about traditional and new thermal metrics, see the [Semiconductor and IC Package Thermal Metrics Application Report](#).

## 6.5 Electrical Characteristics

T<sub>J</sub> = -40°C to +125°C, V<sub>CC</sub> = Internal 4.5V LDO, both TPSM8A29 and TPSM8A28 (unless otherwise noted)

PARAMETER		TEST CONDITIONS	MIN	TYP	MAX	UNIT
<b>SUPPLY CURRENT</b>						
I <sub>Q_VIN</sub>	V <sub>IN</sub> operating nonswitching supply current	V <sub>EN</sub> = 2 V, V <sub>FB</sub> = 0.65 V, V <sub>IN</sub> = 12 V, no external bias on the VCC pin		680	850	μA
I <sub>SD_VIN</sub>	V <sub>IN</sub> shutdown supply current	V <sub>EN</sub> = 0 V, V <sub>IN</sub> = 12 V, no external bias on the VCC pin		9.5	20	μA
I <sub>Q_VCC</sub>	VCC quiescent current	T <sub>J</sub> = 25°C, V <sub>EN</sub> = 2 V, V <sub>FB</sub> = 0.65 V, V <sub>IN</sub> = 5 V, 5.0 V external bias on the VCC pin		680	820	μA
I <sub>SD_VCC</sub>	VCC shutdown current	T <sub>J</sub> = 25°C, V <sub>EN</sub> = 0 V, V <sub>IN</sub> = 0 V, 5.0 V external bias on the VCC pin		75	85	μA
<b>REFERENCE VOLTAGE</b>						
V <sub>INTREF</sub>	Internal REF voltage	T <sub>J</sub> = 25°C		600		mV
	Internal REF voltage tolerance	T <sub>J</sub> = 0°C to 70°C	597		603	mV
	Internal REF voltage tolerance	T <sub>J</sub> = -40°C to 125°C	594		606	mV
I <sub>FB</sub>	FB input current	V <sub>FB</sub> = V <sub>INTREF</sub>		50	100	nA
<b>OUTPUT DISCHARGE</b>						
R <sub>Dischg</sub>	Output discharge resistance	V <sub>IN</sub> = 12 V, VCC = internal LDO, V <sub>sw</sub> = 0.5 V, power conversion disabled		70		Ω
<b>SWITCHING FREQUENCY</b>						
f <sub>sw</sub>	VO switching frequency, FCCM operation	V <sub>IN</sub> = 12 V, V <sub>OUT</sub> = 1.2 V, R <sub>MODE</sub> = 0 Ω to AGND	490	620	750	kHz
		V <sub>IN</sub> = 12 V, V <sub>OUT</sub> = 1.2 V, R <sub>MODE</sub> = 30.1 kΩ to AGND	720	800	880	
		V <sub>IN</sub> = 12 V, V <sub>OUT</sub> = 1.2 V, R <sub>MODE</sub> = 60.4 kΩ to AGND	840	1000	1250	
t <sub>ON(min)</sub>	Minimum on time	T <sub>J</sub> = 25°C <sup>(1)</sup>		70	85	ns
t <sub>OFF(min)</sub>	Minimum off time	T <sub>J</sub> = 25°C, HS FET gate falling to rising <sup>(1)</sup>			220	ns
<b>ENABLE</b>						
V <sub>ENH</sub>	EN enable threshold voltage (rising)		1.17	1.22	1.27	V
V <sub>ENL</sub>	EN disable threshold voltage (falling)		0.97	1.02	1.07	V
V <sub>ENHYST</sub>	EN hysteresis voltage			0.2		V
V <sub>ENLEAK</sub>	EN input leakage current	V <sub>EN</sub> = V		0.5	5	μA
	EN internal pulldown resistance	EN pin to AGND. EN floating disables the converter.		6500		kΩ
<b>INTERNAL VCC LDO</b>						
VCC	Internal LDO output voltage	V <sub>IN</sub> = 12 V, I <sub>LOAD</sub> = 2 mA	4.32	4.5	4.68	V

## 6.5 Electrical Characteristics (continued)

$T_J = -40^\circ\text{C}$  to  $+125^\circ\text{C}$ , VCC = Internal 4.5V LDO, both TPSM8A29 and TPSM8A28 (unless otherwise noted)

PARAMETER		TEST CONDITIONS	MIN	TYP	MAX	UNIT
VCC <sub>UVLO</sub>	VCC undervoltage-lockout (UVLO) threshold voltage	VCC rising	2.80	2.87	2.94	V
		VCC falling	2.62	2.7	2.77	V
VCC <sub>UVLO</sub>	VCC undervoltage-lockout (UVLO) threshold voltage	VCC hysteresis		0.17		V
VCC <sub>DO</sub>	LDO low-droop dropout voltage	V <sub>IN</sub> = 3.0 V, I <sub>VCC_LOAD</sub> = 2 mA, T <sub>J</sub> = 25°C		62	75	mV
	LDO overcurrent limit	All VINs, all temperature		105	158	mA
<b>STARTUP</b>						
t <sub>SS</sub>	Soft-start time	V <sub>O</sub> rising from 0 V to 95% of final setpoint, C <sub>SS/REFIN</sub> = open	1	1.5		ms
	SS/REFIN sourcing current	V <sub>SS/REFIN</sub> = 0 V		36		μA
	SS/REFIN sinking current	V <sub>SS/REFIN</sub> = 1 V		12		μA
	EN to first switching delay, internal LDO	The delay from EN goes high to the first SW rising edge with internal LDO configuration. CVCC = 2.2 μF. CSS/REFIN = 220 nF		0.93	2	ms
	EN to first switching delay, external VCC bias	The delay from EN goes high to the first SW rising edge with external VCC bias configuration. VCC bias must reach regulation before EN ramp up. CSS/REFIN = 220 nF.		550	900	μs
<b>PGOOD COMPARATOR</b>						
V <sub>PGTH</sub>	PGOOD threshold	FB rising, PGOOD low to high	89%	92.5%	95%	
		FB rising, PGOOD high to low	113%	116%	119%	
		FB falling, PGOOD high to low	77%	80%	83%	
V <sub>PGTH</sub>	OOB (out-of-bounds) threshold	FB rising, PGOOD stays high	103%	105.5%	108%	
I <sub>PG</sub>	PGOOD sink current	V <sub>PGOOD</sub> = 0.4 V, V <sub>IN</sub> = 12 V, VCC = Internal LDO			25	mA
I <sub>PG</sub>	PGOOD low-level output voltage	I <sub>PGOOD</sub> = 5.5 mA, V <sub>IN</sub> = 12 V, VCC = internal LDO			400	mV
t <sub>PG_delay</sub>	PGOOD delay time	Delay for PGOOD from low to high		1.0	1.4	ms
		Delay for PGOOD from high to low		0.5	5	μs
I <sub>PG_lkg</sub>	PGOOD leakage current when pulled high	T <sub>J</sub> = 25°C, V <sub>PGOOD</sub> = 3.3 V, V <sub>FB</sub> = V <sub>INTREF</sub>			5	μA
	PGOOD clamp low-level output voltage	V <sub>IN</sub> = 0 V, VCC = 0 V, V <sub>EN</sub> = 0 V, PGOOD pulled up to 3.3 V through a 100-kΩ resistor		710	850	mV
		V <sub>IN</sub> = 0 V, VCC = 0 V, V <sub>EN</sub> = 0 V, PGOOD pulled up to 3.3 V through a 10-kΩ resistor		850	1000	mV
	Minimum VCC for valid PGOOD output				1.5	V
<b>OVERCURRENT PROTECTION</b>						
R <sub>TRIP</sub>	TRIP pin resistance range	TPSM8A28	4.02		14.7	kΩ
R <sub>TRIP</sub>	TRIP pin resistance range	TPSM8A29	0		14.7	kΩ
I <sub>OCL</sub>	Current limit threshold, TPSM8A29 only	Valley current on LS FET, 0 kΩ ≤ R <sub>TRIP</sub> ≤ 3.3 kΩ TPSM8A29 only	14.8	18.4	21.7	A
I <sub>OCL</sub>	Current limit threshold	Valley current on LS FET, R <sub>TRIP</sub> = 4.02 kΩ	12.0	14.2	16.3	A
I <sub>OCL</sub>	Current limit threshold	Valley current on LS FET, R <sub>TRIP</sub> = 4.99 kΩ	9.9	12.0	14.1	A
I <sub>OCL</sub>	Current limit threshold	Valley current on LS FET, R <sub>TRIP</sub> = 10 kΩ	3.9	6.0	8.1	A
K <sub>OCL</sub>	K <sub>OCL</sub> for R <sub>TRIP</sub> equation			60000		A Ω
I <sub>NOCL</sub>	Negative current limit threshold	All VINs	-12	-10	-8	A

## 6.5 Electrical Characteristics (continued)

$T_J = -40^\circ\text{C}$  to  $+125^\circ\text{C}$ ,  $V_{CC} =$  Internal 4.5V LDO, both TPSM8A29 and TPSM8A28 (unless otherwise noted)

PARAMETER		TEST CONDITIONS	MIN	TYP	MAX	UNIT
$I_{ZC}$	Zero-cross detection current threshold, open loop	$V_{IN} = 12\text{ V}$ , $V_{CC} =$ Internal LDO		400		mA
<b>UVLO</b>						
$V_{INUVLO}$	$V_{IN}$ UVLO threshold voltage	Rising	2.1	2.4	2.7	V
		Falling	1.55	1.85	2.15	V
$V_{OVP}$	Overshoot-protection (OVP) threshold voltage		113%	116%	119%	
<b>THERMAL SHUTDOWN</b>						
$T_{SDN}$	Thermal shutdown threshold <sup>(1)</sup>	Temperature rising		165		$^\circ\text{C}$
	Thermal shutdown hysteresis <sup>(1)</sup>			30		$^\circ\text{C}$

(1) Specified by design. Not production tested.

## 6.6 Typical Characteristics



图 6-1. Efficiency vs Output Current, 12 V<sub>IN</sub>, 600 KHz, Skip Mode, Internal VCC LDO



图 6-2. Efficiency vs Output Current, 12 V<sub>IN</sub>, 600 KHz, FCCM, Internal VCC LDO

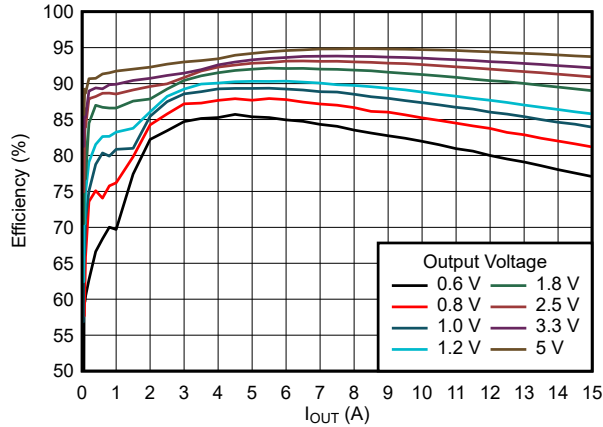

图 6-3. SOA, 12 V 1V<sub>out\_IN</sub>, 600 KHz, FCCM, Internal VCC LDO

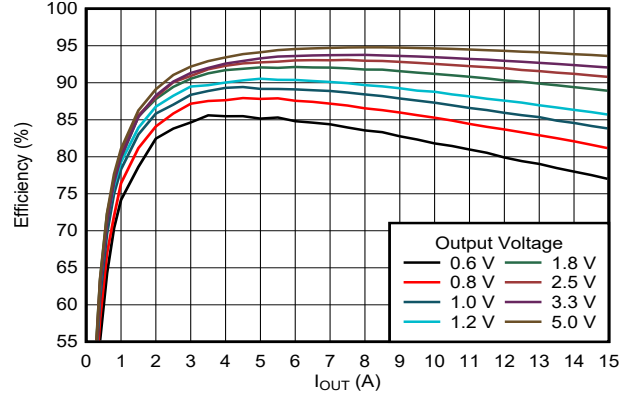

图 6-4. SOA, 12 V 3.3V<sub>out\_IN</sub>, 600 KHz, FCCM, Internal VCC LDO

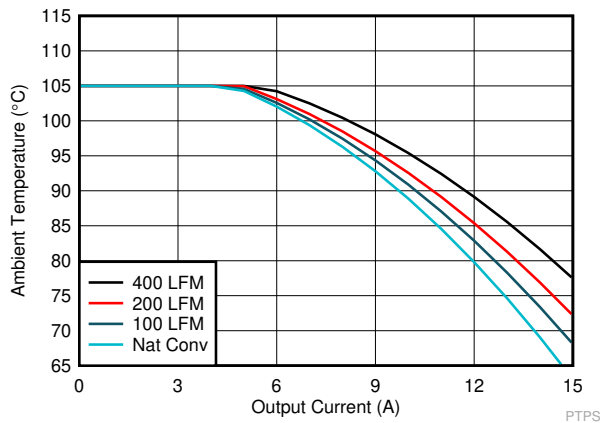

图 6-5. SOA, 12 V 5.0V<sub>out\_IN</sub>, 600 KHz, FCCM, Internal VCC LDO

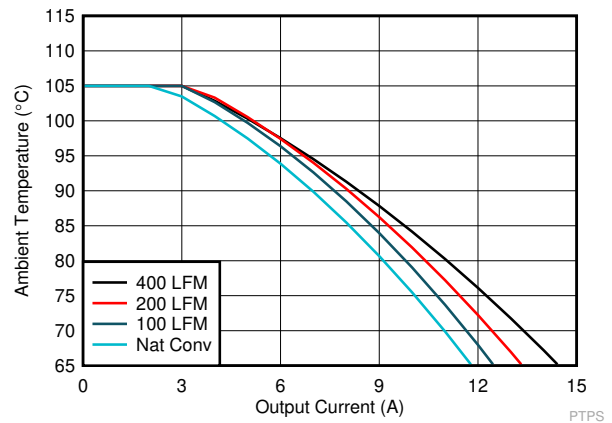

图 6-6. SOA, 5Vin 1.0V<sub>out\_IN</sub>, 600 KHz, FCCM, Internal VCC LDO

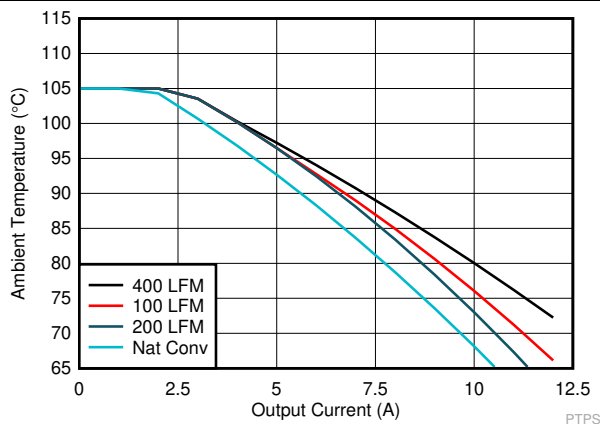

## 7 Detailed Description

### 7.1 Overview

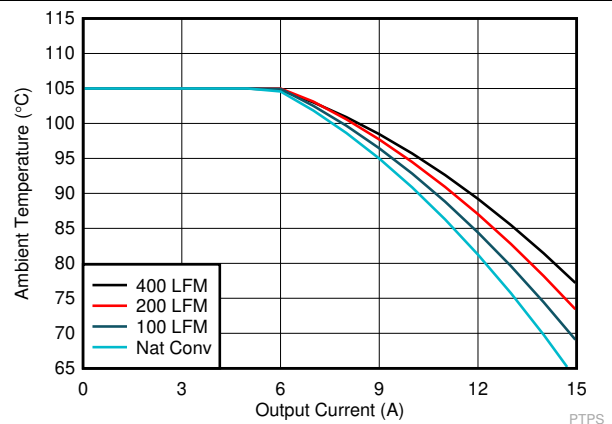
The TPSM8A28 and TPSM8A29 power modules feature high efficiency and small footprint. These devices are suitable for low voltage point-of-load applications up to 15 A. The conversion input voltage ranges from 2.7 V to 16 V, and the external VCC input voltage ranges from 4.75 V to 5.3 V, and output voltage ranges from 0.6 V to 5.5 V. These power modules use D-CAP3™ mode control combined with adaptive on-time architecture. The D-CAP3™ mode uses emulated current information to control the modulation and tracks the preset switching frequency over a wide range of input and output voltages. Advantages of this control scheme is that it does not require a phase-compensation network outside, which makes the device easy-to-use and also allows low external component count. Further advantage of this control scheme is that it supports stable operation with all low-ESR output capacitors (such as ceramic capacitor and low-ESR polymer capacitor). It also adjusts switching frequency as needed during load-step transient.

### 7.2 Functional Block Diagram

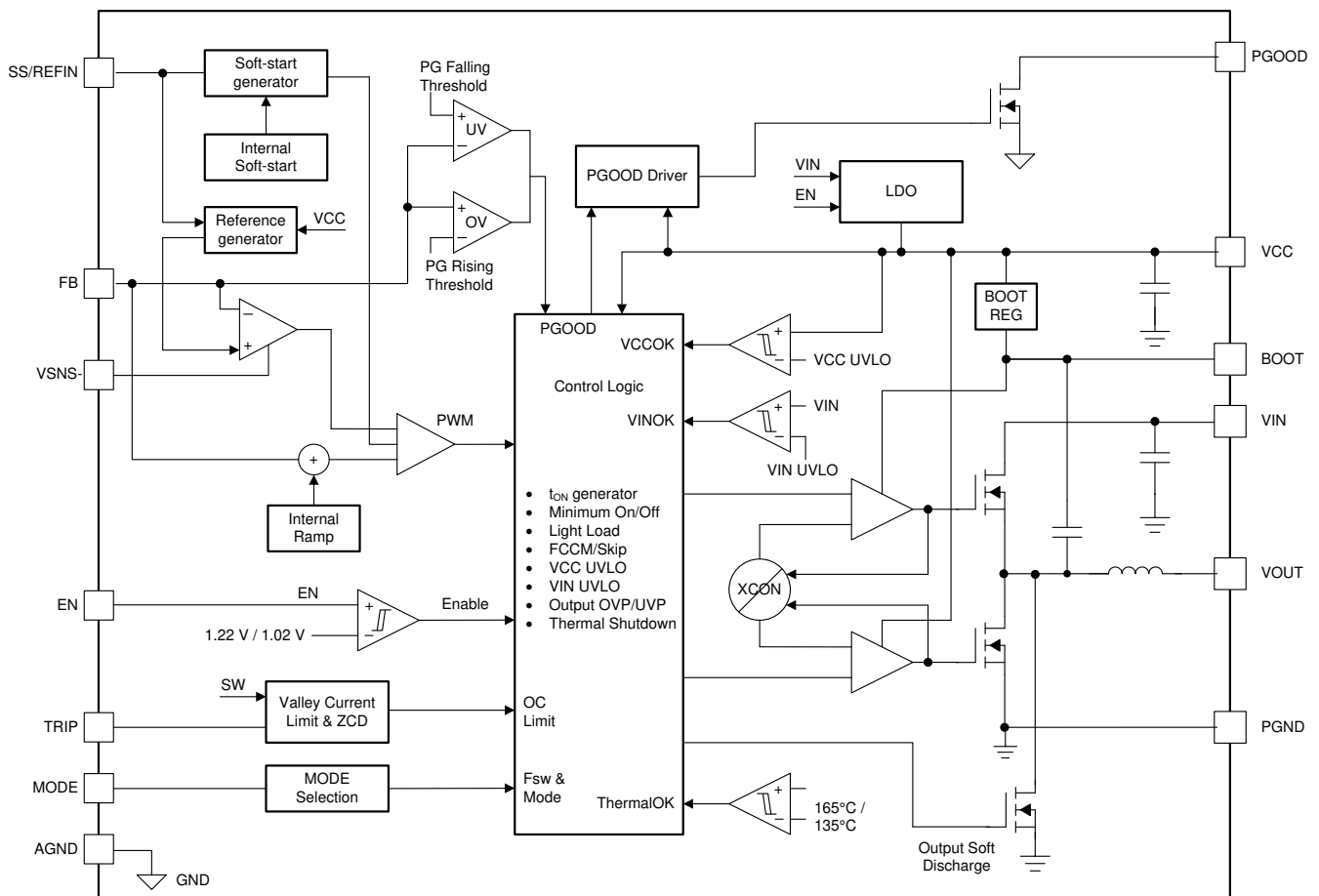

## 7.3 Feature Description

### 7.3.1 Internal VCC LDO and Using External Bias on VCC Pin

The TPSM8A28 and TPSM8A29 power modules have internal 4.5-V LDO that takes input from VIN rail and output to VCC. When the  $V_{IN}$  voltage rises above the  $V_{IN_{UVLO}}$  rising threshold, and the EN voltage rises above the enable threshold (typically 1.22 V), the internal LDO is enabled and starts regulating output voltage on the VCC pin. The VCC voltage provides the bias voltage for the internal analog circuitry and also provides the supply voltage for the gate drives.

The VCC pin has an internal bypass capacitor integrated inside the module and does not require external bypassing. An external bias that is above the output voltage of the internal LDO can override the internal LDO. This enhances the efficiency of the converter because the VCC current now runs off this external bias instead of the internal linear regulator.

The VCC UVLO circuit monitors the VCC pin voltage and disables the whole converter when VCC falls below the VCC UVLO falling threshold. Maintaining a stable and clean VCC voltage is required for a smooth operation of the device.

The following are considerations when using an external bias on the VCC pin:

- When the external bias is applied on the VCC pin early enough (for example, before EN signal comes in), the internal LDO is always forced off and the internal analog circuits has a stable power supply rail at their power enable.
- (Not recommended) If the external bias is applied on the VCC pin late (for example, after EN signal comes in), any power-up and power-down sequencing can be applied as long as there is no excess current pulled out of the VCC pin. It is important to understand that an external discharge path on the VCC pin, which can pull a current higher than the current limit of the internal LDO from the VCC pin, can potentially turn off VCC LDO thereby shutting down the converter output.
- A good power-up sequence is when at least the VIN UVLO rising threshold or EN rising threshold is satisfied later than the VCC UVLO rising threshold. For example, VIN applied first, then the external bias applied, and then EN signal goes high.

### 7.3.2 Enable

When the EN pin voltage rises above the enable threshold voltage (typically 1.22 V) and VIN rises above the VIN UVLO rising threshold, the device enters its internal power-up sequence. The EN to first switching delay is specified in the Start-Up section in the Electrical Characteristics table.

When using the internal VCC LDO, the internal power-up sequence includes three sequential steps. During the first period, the VCC voltage is charged up on the VCC bypass capacitor by a 11-mA current source. The length of this VCC LDO start-up time varies with the capacitance on the VCC pin. However, if  $V_{IN}$  voltage ramps up very slowly, the VCC LDO output voltage is limited by the  $V_{IN}$  voltage level, so the VCC LDO start-up time can be extended longer. Since the VCC LDO start-up time is relatively long, the internal  $V_{INTREF}$  build-up happens and finishes during this period. Once the VCC voltage crosses above the VCC UVLO rising threshold (typically 2.87 V), the device moves to the second step, power-on delay. The MODE pin setting detection, SS/REFIN pin detection, and control loop initialization are finished within this 285- $\mu$ s delay. The soft-start ramp starts when the 285- $\mu$ s power-on delay finishes. During the soft-start ramp power stage, switching does not happen until the SS/REFIN pin voltage reaches 50 mV. This introduces a SS delay, which varies with the external capacitance on the SS/REFIN pin.

**图 7-1** shows an example where the VIN UVLO rising threshold is satisfied earlier than the EN rising threshold. In this scenario, the VCC UVLO rising threshold becomes the gating signal to start the internal power-up sequence, and the sequence between VIN and EN does not matter.

When using an external bias on the VCC pin, the internal power-up sequence still includes three sequential steps. The first period is much shorter since the VCC voltage is built up already. A 100- $\mu$ s period allows the internal references start up and stabilize. This 100- $\mu$ s period includes not only the 0.6-V  $V_{INTREF}$ , but also all of the other reference voltages for various functions. The device then moves to the second step, power-on delay. The MODE pin setting detection, SS/REFIN pin detection, and control loop initialization are finished within this

285- $\mu$ s delay. The soft-start ramp starts when the 285- $\mu$ s power-on delay finishes. During the soft-start ramp power stage, switching does not happen until the SS/REFIN pin voltage reaches 50 mV. This introduced a SS delay, which varies with the external capacitance on the SS/REFIN pin.

图 7-2 shows an example where both the VIN UVLO rising threshold and EN rising threshold are satisfied later than the VCC UVLO rising threshold. In this scenario, the VIN UVLO rising threshold or EN rising threshold, whichever is satisfied later, becomes the gating signal to start the internal power-up sequence.



图 7-1. Internal Power-up Sequence Using Internal LDO



图 7-2. Internal Power-up Sequence Using External Bias

The EN pin has an internal filter to avoid unexpected ON or OFF due to small glitches. The time constant of this RC filter is 5  $\mu$ s. For example, when applying a 3.3-V voltage source on the EN pin, which jumps from 0 V to 3.3 V with ideal rising edge, the internal EN signal reaches 2.086 V after 5  $\mu$ s, which is 63.2% of applied 3.3-V voltage level.

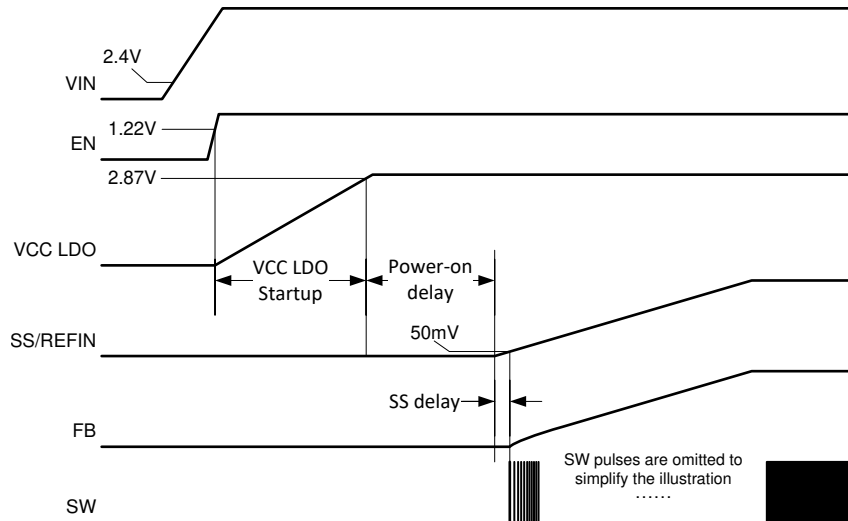
A internal pulldown resistor is implemented between the EN pin and AGND pin. To avoid impact to the EN rising/falling threshold, this internal pulldown resistor is set to 6.5 M $\Omega$ . With this pulldown resistor, floating the EN pin before start-up keeps the device under disabled state. During nominal operation when the power stage switches, this large internal pulldown resistor may not have enough noise immunity to hold the EN pin low.

The recommended operating condition for EN pin is maximum 5.5 V. *Do not* connect the EN pin to the VIN pin directly.

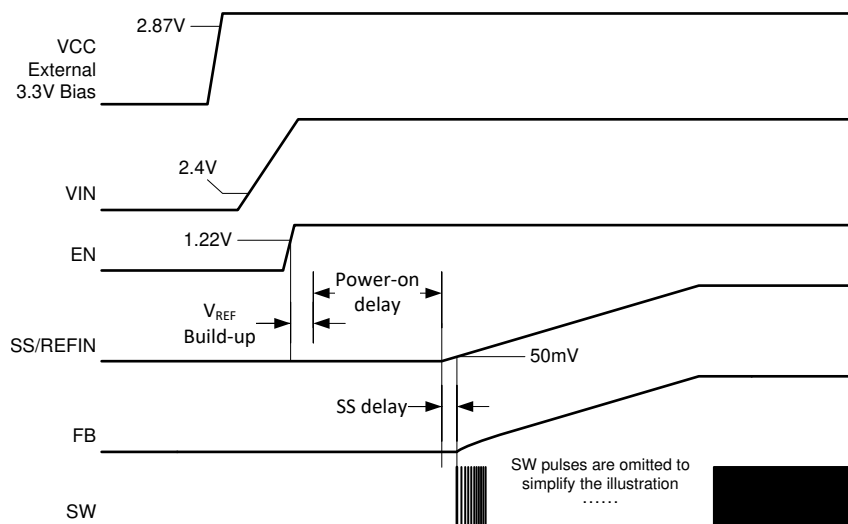
### 7.3.3 Output Voltage Setting

The output voltage is programmed by the voltage divider resistors,  $R_{FB\_HS}$  and  $R_{FB\_LS}$ . Connect  $R_{FB\_HS}$  between the FB pin and the positive node of the load, and connect  $R_{FB\_LS}$  between the FB pin and the VSNS – pin. The recommended  $R_{FB\_LS}$  value is 10 k $\Omega$ , ranging from 1 k $\Omega$  to 20 k $\Omega$ . Determine  $R_{FB\_HS}$  by using [方程式 1](#).

$$R_{FB\_HS} = \frac{V_O - V_{INTREF}}{V_{INTREF}} \times R_{FB\_LS} \quad (1)$$

The FB accuracy is determined by two elements. The first element is the accuracy of the internal 600-mV reference, which is applied to the SS/REFIN pin unless an external  $V_{REF}$  is applied. Both TPSM8A28 and TPSM8A29 offer  $\pm 0.5\%$   $V_{INTREF}$  accuracy from a 0°C to 85°C temperature range, and  $\pm 1.0\%$   $V_{INTREF}$  accuracy from a -40°C to 125°C temperature range. The second element is the SS/REFIN-to-FB accuracy, which tells the user how accurately the control loop regulates the FB node to the SS/REFIN pin. The TPSM8A29 offers  $\pm 0.6\%$  SS/REFIN-to-FB accuracy from a -40°C to 125°C temperature range. For example, when operating from a 0°C to 85°C temperature range, the total FB accuracy is  $\pm 1.1\%$ , which includes the impact from the chip junction temperature and also the variation from part to part.

To improve the overall  $V_{OUT}$  accuracy, using  $\pm 1\%$  accuracy or better resistor for FB voltage divider is highly recommended.

Regardless of remote sensing or single-end sensing connection, the FB voltage divider,  $R_{FB\_HS}$  and  $R_{FB\_LS}$ , must be always placed as close as possible to the device.

#### 7.3.3.1 Remote Sense

The TPSM8A28 and TPSM8A29 modules feature remote sense function through the FB and VSNS – pins. Remote sense function compensates a potential voltage drop on the PCB traces, helping maintain  $V_{OUT}$  tolerance under steady state operation and load transient event. Connecting the FB voltage divider resistors to the remote location allows sensing of the output voltage at a remote location. The connections from the FB voltage divider resistors to the remote location must be a pair of PCB traces with at least 12-mil trace width, and must implement Kelvin sensing across a high bypass capacitor of 0.1  $\mu$ F or higher. The ground connection of the remote sensing signal must be connected to the VSNS – pin. The  $V_{OUT}$  connection of the remote sensing signal must be connected to the feedback resistor divider with the lower feedback resistor,  $R_{FB\_LS}$ , terminated at the VSNS – pin. To maintain stable output voltage and minimize the ripple, the pair of remote sensing lines must stay away from any noise sources such as inductor and SW nodes, or high frequency clock lines. It is recommended to shield the pair of remote sensing lines with ground planes above and below.

Single-ended  $V_O$  sensing is often used for local sensing. For this configuration, connect the higher FB resistor,  $R_{FB\_HS}$ , to a high-frequency local bypass capacitor of 0.1  $\mu$ F or higher, and short VSNS – to AGND.

The recommended VSNS – operating range (refer to AGND pin) is - 50 mV to +50 mV.

### 7.3.4 Internal Fixed Soft Start and External Adjustable Soft Start

The TPSM8A28 and TPSM8A29 power modules allow both internal fixed soft start and external adjustable soft start. The internal soft-start time is 1.5 ms. The soft-start time can be increased by adding a soft-start (SS) capacitor between the SS/REFIN and VSNS – pins. The total SS capacitor value can be determined by [方程式 2](#). The device follows the longer SS ramp among the internal SS time and the SS time determined by the external SS capacitors.

The device does not require a capacitor from the SS/REFIN pin to AGND, so it is not recommended to place a capacitor from the SS/REFIN pin to AGND. If both  $C_{SS/REFIN\text{-to-VSNS-}}$  and  $C_{SS/REFIN\text{-to-AGND}}$  capacitors exist, place  $C_{SS/REFIN\text{-to-VSNS-}}$  more closely to the shortest trace back to the VSNS – pin.

The SS/REFIN pin is discharged internally during the internal power-on delay to make sure the soft-start ramp always starts from zero.

$$C_{SS}(\text{nF}) = \frac{t_{SS}(\text{ms}) \times 36(\mu\text{A})}{V_{\text{INTREF}}(\text{V})} \quad (2)$$

### 7.3.5 External REFIN for Output Voltage Tracking

The TPSM8A28 and TPSM8A29 provide analog input pin (SS/REFIN) to accept an external reference (that is, a DC voltage source). The device always looks at the voltage on this SS/REFIN pin as the reference for the control loop. When an external voltage reference is applied between the SS/REFIN pin and VSNS - pin, it acts as the reference voltage, so the FB voltage follows this external voltage reference exactly. The same  $\pm 0.6\%$  SS/REFIN-to-FB accuracy from a  $-40^{\circ}\text{C}$  to  $125^{\circ}\text{C}$  temperature range applies here too.

In the middle of internal power-on delay, a detection circuit senses the voltage on the SS/REFIN pin to tell whether an active DC voltage source is applied. Before the detection happens, the SS/REFIN pin tries to discharge any energy on the SS/REFIN capacitors through an internal  $120\text{-}\Omega$  resistor to AGND, lasting  $125\ \mu\text{s}$ . Then, within a  $32\text{-}\mu\text{s}$  window, the detection circuit compares the SS/REFIN pin voltage with an internal reference equal to  $89\%$  of  $V_{\text{INTREF}}$ . This discharge operation makes sure a SS capacitor with left-over energy is not wrongly detected as a voltage reference. If the external voltage reference failed to supply sufficient current and hold a voltage level higher than  $89\%$  of  $V_{\text{INTREF}}$ , the SS/REFIN detection circuit provides a wrong detection result.

If the detection result is that the SS/REFIN pin voltage holds higher than  $89\%$  of  $V_{\text{INTREF}}$ , which tells an active DC voltage source is used as external reference, the device always uses the SS/REFIN pin voltage instead of the internal  $V_{\text{INTREF}}$  as the reference for PGOOD threshold,  $V_{\text{OUT}}$  OVP, and  $V_{\text{OUT}}$  UVP threshold. On this configuration, since the SS/REFIN pin senses a DC voltage and no soft-start ramp on this pin, the internal fixed soft start is used for start-up. Once the internal soft-start ramp finishes, the power-good signal becomes high after a  $1.06\text{-ms}$  internal delay. The whole internal soft-start ramp takes  $2\ \text{ms}$  to finish because the soft-start ramp goes beyond  $V_{\text{INTREF}}$ .

If the detection result is that SS/REFIN pin voltage falls below  $89\%$  of  $V_{\text{INTREF}}$ , which tells no external reference is connected, the device first uses the internal fixed  $V_{\text{INTREF}}$  as the reference for PGOOD threshold,  $V_{\text{OUT}}$  OVP, and  $V_{\text{OUT}}$  UVP threshold. On this configuration, given the SS/REFIN pin sees a soft-start ramp on this pin, the slower ramp amongst the internal fixed soft start and the external soft start determines the start-up of FB. Once both the internal and external soft-start ramp finishes, the power-good signal becomes high after a  $1.06\text{-ms}$  internal delay. The whole internal soft-start ramp takes  $2\ \text{ms}$  to finish. The external soft-start done signal goes high when FB reaches a threshold equal to  $V_{\text{INTREF}} - 50\ \text{mV}$ . The device waits for the PGOOD status transition from low to high, then starts using the SS/REFIN pin voltage instead of the internal  $V_{\text{INTREF}}$  as the reference for PGOOD threshold,  $V_{\text{OUT}}$  OVP, and  $V_{\text{OUT}}$  UVP threshold.

On this external REFIN configuration, applying a stabilized DC external reference to SS/REFIN pin before the EN high signal is recommended. During the internal power-on delay, the external reference must be capable of holding the SS/REFIN pin equal to or higher than  $89\%$  of  $V_{\text{INTREF}}$ , so that the device can correctly detect the external reference and choose the right thresholds for power good,  $V_{\text{OUT}}$  OVP, and  $V_{\text{OUT}}$  UVP. After the power-good status transits from low to high, the external reference can be set in a range of  $0.5\ \text{V}$  to  $1.2\ \text{V}$ . To overdrive the SS/REFIN pin during nominal operation, the external reference has to be able to sink more than  $36\text{-}\mu\text{A}$  current if the external reference is lower than the internal  $V_{\text{INTREF}}$ , or source more than  $12\text{-}\mu\text{A}$  current if the external reference is higher than the internal  $V_{\text{INTREF}}$ . When driving the SS/REFIN pin by an external reference through a resistor divider, the resistance of the divider must be low enough to provide the sinking or sourcing current capability.

If the external voltage source must transition up and down between any two voltage levels, the slew rate must be no more than  $1\ \text{mV}/\mu\text{s}$ .

### 7.3.6 Frequency and Operation Mode Selection

The TPSM8A29 provides forced CCM operation for tight output ripple applications and auto-skip Eco-mode for high light-load efficiency. The TPSM8A29 allows users to select the switching frequency and operation mode by connecting a resistor from the MODE pin to the AGND pin. 表 7-1 lists the resistor values for the switching

frequency and operation mode selection. TI recommends  $\pm 1\%$  tolerance resistors with a typical temperature coefficient of  $\pm 100$  ppm/ $^{\circ}\text{C}$ .

The MODE state is set and latched during the internal power-on delay period. Changing the MODE pin resistance after the power-on delay does not change the status of the device. The internal circuit sets the MODE pin status to 600 kHz / Skip mode if the MODE pin is left open during the power-on delay period.

To make sure the internal circuit detects the desired option correctly, *do not* place any capacitor on the MODE pin.

**表 7-1. MODE Pin Selection**

MODE PIN CONNECTIONS	OPERATION MODE UNDER LIGHT LOAD	SWITCHING FREQUENCY ( $f_{\text{sw}}$ ) (kHz)
Short to VCC	Skip-mode	600
243-k $\Omega$ $\pm 10\%$ to AGND	Skip-mode	800
121-k $\Omega$ $\pm 10\%$ to AGND	Skip-mode	1000
60.4-k $\Omega$ $\pm 10\%$ to AGND	Forced CCM	1000
30.1-k $\Omega$ $\pm 10\%$ to AGND	Forced CCM	800
Short to AGND	Forced CCM	600

### 7.3.7 D-CAP3™ Control

The TPSM8A28 and TPSM8A29 use D-CAP3™ mode control to achieve fast load transient while maintaining the ease-of-use feature. The D-CAP3™ control architecture includes an internal ripple generation network, enabling the use of very low ESR output capacitors such as multi-layered ceramic capacitors (MLCC) and low-ESR polymer capacitors. No external current sensing network or voltage compensators are required with D-CAP3™ control architecture. The role of the internal ripple generation network is to emulate the ripple component of the inductor current information and then combine it with the voltage feedback signal to regulate the loop operation. The amplitude of the ramp is determined by  $V_{\text{IN}}$ ,  $V_{\text{OUT}}$ , operating frequency, and the R-C time-constant of the internal ramp circuit. At different switching frequency settings (see 表 7-1), the R-C time-constant varies to maintain a relatively constant ramp amplitude. Also, the device uses internal circuitry to cancel the DC offset caused by the injected ramp, and significantly reduce the DC offset caused by the output ripple voltage, especially under light-load condition.

For any control topologies supporting no external compensation design, there is a minimum range, maximum range, or both, of the output filter it can support. The output filter used is a low-pass L-C circuit. This L-C filter has double pole that is described in 方程式 3.

$$f_p = \frac{1}{2 \times \pi \times \sqrt{L_{\text{OUT}} \times C_{\text{OUT}}}} \quad (3)$$

At low frequencies, the overall loop gain is set by the output set-point resistor divider network and the internal gain. The low frequency L-C double pole has a 180-degree drop in phase. At the output filter frequency, the gain rolls off at a  $-40$  dB per decade rate and the phase drops rapidly. The internal ripple generation network introduces a high-frequency zero that reduces the gain roll off from  $-40$  dB to  $-20$  dB per decade and increases the phase by 90 degrees per decade above the zero frequency.

The inductor and capacitor selected for the output filter must be such that the double pole of 方程式 3 is located no higher than 1/30th of operating frequency. Choose very small output capacitance leads to relatively high frequency L-C double pole, which allows the overall loop gain to stay high until the L-C double frequency. Make sure the zero from the internal ripple generation network has relatively high frequency as well. The loop with very small output capacitance can have too high of crossover frequency, which is not desired. Use 表 7-2 to help locate the internal zero based on the selected switching frequency.

**表 7-2. Locating the Zero**

SWITCHING FREQUENCIES ( $f_{sw}$ ) (kHz)	ZERO ( $f_z$ ) LOCATION (kHz)
600	84.5
800	84.5
1000	106

In general, where reasonable (or smaller) output capacitance is desired, the output ripple requirement and load transient requirement can be used to determine the necessary output capacitance for stable operation.

$$f_p = \frac{1}{2 \times \pi \times \sqrt{L_{OUT} \times C_{OUT}}} = f_z \quad (4)$$

For the maximum output capacitance recommendation, select the inductor and capacitor values so that the L-C double pole frequency is no less than 1/100th of the operating frequency. With this starting point, verify the small signal response on the board using the following one criteria:

- Phase margin at the loop crossover is greater than 50 degrees

The actual maximum output capacitance can go higher as long as the phase margin is greater than 50 degrees. However, small signal measurement (bode plot) must be done to confirm the design.

If MLCC is used, consider the derating characteristics to determine the final output capacitance for the design. For example, when using an MLCC with specifications of 10  $\mu$ F, X5R, and 6.3 V, the derating by DC bias and AC bias are 80% and 50%, respectively. The effective derating is the product of these two factors, which in this case is 40% and 4  $\mu$ F. Consult with capacitor manufacturers for specific characteristics of the capacitors to be used in the system/applications.

For higher output voltage at or above 2 V, additional phase boost can be required in order to secure sufficient phase margin due to phase delay/loss for higher output voltage (large on time ( $t_{ON}$ )) setting in a fixed on-time topology based operation. A feedforward capacitor placed in parallel with  $R_{FB\_HS}$  was found to be very effective to boost the phase margin at loop crossover. Refer to [Optimizing Transient Response of Internally Compensated dc-dc Converters With Feedforward Capacitor Application Report](#) for details.

Besides boosting the phase, a feedforward capacitor feeds more  $V_{OUT}$  node information into the FB node by the AC coupling. This feedforward during load transient event enables the control loop a faster response to  $V_{OUT}$  deviation. However, this feedforward during steady state operation also feeds more  $V_{OUT}$  ripple and noise into FB. High ripple and noise on FB usually leads to more jitter, or even double pulse behavior. To determine the final feedforward capacitor value, impacts to phase margin, load transient performance, and ripple and noise on FB must be all considered. Using Frequency Analysis equipment to measure the crossover frequency and the phase margin is recommended.

### 7.3.8 Low-Side FET Zero-Crossing

A zero-crossing circuit is used to perform the zero inductor-current detection during Skip-mode operation. The function compensates the inherent offset voltage of the Z-C comparator and delay time of the Z-C detection circuit. The zero-crossing threshold is set to a positive value to avoid negative inductor current. As a result, the TPSM8A28 and TPSM8A29 power modules deliver better light-load efficiency.

### 7.3.9 Current Sense and Positive Overcurrent Protection

For a buck converter, during the on time of the high-side FET, the switch current increases at a linear rate determined by the following:

- input voltage
- output voltage
- the on time
- the output inductor value

During the on time of the low-side FET, this current decreases linearly. The average value of the switch current equals to the load current.

The output overcurrent limit (OCL) is implemented using a cycle-by-cycle valley current detect control circuit. The inductor current is monitored during the on time of the low-side FET by measuring the low-side FET drain-to-source current. If the measured drain-to-source current of the low-side FET is above the current limit threshold, the low-side FET stays ON until the current level becomes lower than the current limit threshold. This type of behavior reduces the average output current sourced by the device. During an overcurrent condition, the current to the load exceeds the current to the output capacitors. Thus, the output voltage tends to decrease. Eventually, when the output voltage falls below the undervoltage-protection threshold (80%), the UVP comparator detects it and shuts down the device after a wait time of 68  $\mu$ s. The device then enters a hiccup sleep period for approximately 14 ms. After this waiting period, the device attempts to start up again/remains latched off state (both high-side and low-side FETs are latched off) until a reset of VIN or a re-toggling on the EN pin. 图 7-3 shows the cycle-by-cycle valley current limit behavior as well as the wait time before the device shuts down.

If an OCL condition happens during start-up, the device still has cycle-by-cycle current limit based on low-side valley current. After soft start is finished, the UV event, which is caused by the OC event, shuts down the device and enters Hiccup mode with a wait time of 68  $\mu$ s.

The resistor,  $R_{TRIP}$ , connected from the TRIP pin to AGND sets current limit threshold.  $\pm 1\%$  tolerance resistor is highly recommended because a worse tolerance resistor provides less accurate OCL threshold.

To protect the device from unexpected connection on the TRIP pin, an internal fixed OCL clamp is implemented. This internal OCL clamp limits the maximum valley current on LS FET when TRIP pin has too small resistance to AGND, or is accidentally shorted to ground.

$$R_{TRIP} = \frac{6 \times 10^4}{I_{OCLIM} - \frac{1}{2} \times \frac{(V_{IN} - V_O) \times V_O}{V_{IN}} \times \frac{1}{L \times f_{SW}}} = \frac{K_{OCL}}{I_{OCLIM} - \frac{1}{2} \times \frac{(V_{IN} - V_O) \times V_O}{V_{IN}} \times \frac{1}{L \times f_{SW}}} \quad (5)$$

where

- $I_{OCLIM}$  is overcurrent limit threshold for load current in A
- $R_{TRIP}$  is TRIP resistor value in  $\Omega$
- $V_{IN}$  is input voltage value in V
- $V_O$  is output voltage value in V
- L is output inductor value in  $\mu$ H
- $f_{SW}$  is switching frequency in MHz



图 7-3. Overcurrent Protection



### 7.3.10 Low-Side FET Negative Current Limit

The device has a fixed, cycle-by-cycle negative current limit. Similar with the positive overcurrent limit, the inductor current is monitored during the on time of the low-side FET. To prevent too large negative current flowing through low-side FET, when the low-side FET detects  $-10\text{-A}$  current (typical threshold), the device turns off low-side FET and then turns on high-side FET for a proper on time (determined by  $V_{IN}/V_{O}/f_{SW}$ ). After high-side FET on time expires, the low-side FET turns on again.

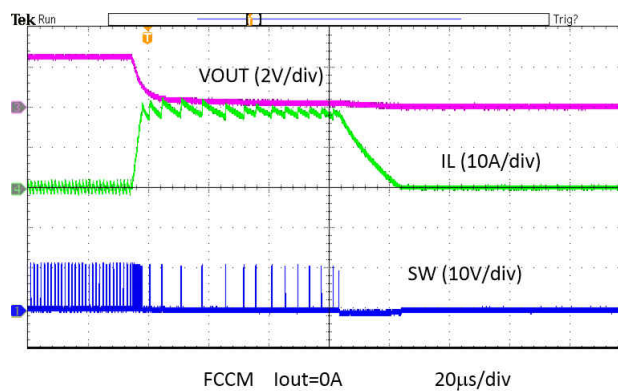
The device must not trigger the  $-10\text{-A}$  negative current limit threshold during nominal operation, unless a too small inductor value is chosen or the inductor becomes saturated. This negative current limit is used to discharge output capacitors during an output OVP or an OOB event. See [节 7.3.12](#) and [节 7.3.13](#) for details.

### 7.3.11 Power Good

TPSM8A28 and TPSM8A29 have power-good output that output high when the converter output voltage is within specification. The power-good output is an open-drain output and must be pulled up to VCC pin or an external voltage source ( $< 5.5\text{ V}$ ) through a pullup resistor (typically  $30.1\text{ k}\Omega$ ). The recommended power-good pullup resistor value is  $1\text{ k}\Omega$  to  $100\text{ k}\Omega$ .

Once both the internal and external soft-start ramp finishes, the power-good signal becomes high after a  $1.06\text{-ms}$  internal delay. The whole internal soft-start ramp takes  $2\text{ ms}$  to finish. The external soft-start done signal goes high when FB reaches a threshold equal to  $V_{INTREF} - 50\text{ mV}$ . If the FB voltage drops to  $80\%$  of the  $V_{INTREF}$  voltage or exceeds  $116\%$  of the  $V_{INTREF}$  voltage, the power-good signal latches low after a  $2\text{-}\mu\text{s}$  internal delay. The power-good signal can only be pulled high again after re-toggling EN or a reset of VIN.

If the input supply fails to power up the device, for example VIN and VCC both stays at zero volts, the power-good pin clamps low by itself when this pin is pulled up through an external resistor.

Once the VCC voltage level rises above the minimum VCC threshold for valid PGOOD output (maximum  $1.5\text{ V}$ ), internal power-good circuit is enabled to hold the PGOOD pin to the default status. By default, PGOOD is pulled low and this low-level output voltage is no more than  $400\text{ mV}$  with  $5.5\text{-mA}$  sinking current. The power-good function is fully activated after the soft-start operation is completed.

### 7.3.12 Overvoltage and Undervoltage Protection

The TPSM8A28 and TPSM8A29 devices monitor a resistor-divided feedback voltage to detect overvoltage and undervoltage events. When the FB voltage becomes lower than  $80\%$  of the  $V_{INTREF}$  voltage, the UVP comparator detects and an internal UVP delay counter begins counting. After the  $68\text{-}\mu\text{s}$  UVP delay time, the device enters Hiccup mode and re-starts with a sleep time of  $14\text{ ms}$ . The UVP function enables after the soft-start period is complete.

When the FB voltage becomes higher than  $116\%$  of the  $V_{INTREF}$  voltage, the OVP comparator detects and the circuit latches OFF the high-side MOSFET driver and turns on the low-side MOSFET until reaching a negative current limit  $I_{NOCL}$ . Upon reaching the negative current limit, the low-side FET is turned off, and the high-side FET is turned on again for a proper on time (determined by  $V_{IN}/V_{O}/f_{SW}$ ). The device operates in this cycle until the output voltage is pulled lower than the UVP threshold voltage for  $68\text{ }\mu\text{s}$ . After the  $68\text{-}\mu\text{s}$  UVP delay time, both the high-side FET and the low-side FET are latched OFF. The fault is cleared with a reset of VIN or by retoggling the EN pin.

During the  $68\text{-}\mu\text{s}$  UVP delay time, if output voltage becomes higher than the UV threshold, thus it is not qualified for the UV event, the timer is reset to zero. When the output voltage triggers the UV threshold again, the timer of the  $68\text{ }\mu\text{s}$  re-starts.

### 7.3.13 Out-Of-Bounds (OOB) Operation

TPSM8A28 and TPSM8A29 devices have out-of-bounds (OOB) overvoltage protection that protects the output load at a much lower overvoltage threshold of  $5\%$  above the  $V_{INTREF}$  voltage. OOB protection does not trigger an overvoltage fault, so the device is on non-latch mode after an OOB event. OOB protection operates as an early no-fault overvoltage-protection mechanism. During the OOB operation, the controller operates in forced CCM mode. Turning on the low-side FET beyond the zero inductor current quickly discharges the output capacitor

thus helps the output voltage to fall quickly towards the setpoint. During the operation, the cycle-by-cycle negative current limit is also activated for the safe operation of the internal FETs.

### 7.3.14 Output Voltage Discharge

When the device is disabled through EN, it enables the output voltage discharge mode. This mode forces both high-side and low-side FETs to latch off, but turns on the discharge FET, which is connected from SW to PGND, to discharge the output voltage. Once the FB voltage drops below 100 mV, the discharge FET is turned off.

The output voltage discharge mode is activated by any of below fault events:

- EN pin goes low to disable the converter.
- Thermal shutdown (OTP) is triggered.
- VCC UVLO (falling) is triggered.
- VIN UVLO (falling) is triggered.

### 7.3.15 UVLO Protection

The device monitors the voltage on both the VIN and the VCC pins. If the VCC pin voltage is lower than the VCC<sub>UVLO</sub> falling threshold voltage, the device shuts off. If the VCC voltage increases beyond the VCC<sub>UVLO</sub> rising threshold voltage, the device turns back on. VCC UVLO is a non-latch protection.

When the VIN pin voltage is lower than the VIN<sub>UVLO</sub> falling threshold voltage but the VCC pin voltage is still higher than the VCC<sub>UVLO</sub> rising threshold voltage, the device stops switching and discharges SS/REFIN pin. Once the VIN voltage increases beyond the VIN<sub>UVLO</sub> rising threshold voltage, the device re-initiates the soft start and switches again. VIN UVLO is a non-latch protection.

### 7.3.16 Thermal Shutdown

The device monitors internal junction temperature. If the temperature exceeds the threshold value (typically 165°C), the device stops switching and discharges the SS/REFIN pin. When the temperature falls approximately 30°C below the threshold value, the device turns back on with a re-initiated soft start. Thermal shutdown is a non-latch protection.

## 7.4 Device Functional Modes

### 7.4.1 Auto-Skip Eco-Mode Light Load Operation

While the MODE pin is pulled to VCC directly or connected to AGND pin through a resistor larger than 121 k $\Omega$ , the device automatically reduces the switching frequency at light-load conditions to maintain high efficiency. This section describes the operation in detail.

As the output current decreases from heavy load condition, the inductor current also decreases until the rippled valley of the inductor current touches zero level. Zero level is the boundary between the continuous-conduction and discontinuous-conduction modes. The synchronous MOSFET turns off when this zero inductor current is detected. As the load current decreases further, the converter runs into discontinuous-conduction mode (DCM). The on time is maintained to a level approximately the same as during continuous-conduction mode operation so that discharging the output capacitor with a smaller load current to the level of the reference voltage requires more time. The transition point to the light-load operation  $I_{OUT(LL)}$  (for example: the threshold between continuous- and discontinuous-conduction mode) is calculated as shown in [方程式 6](#).

$$I_{OUT(LL)} = \frac{1}{2 \times L \times f_{SW}} \times \frac{(V_{IN} - V_{OUT}) \times V_{OUT}}{V_{IN}} \quad (6)$$

where

- $f_{SW}$  is the switching frequency

Using only ceramic capacitors is recommended for Skip mode.

### 7.4.2 Forced Continuous-Conduction Mode

When the MODE pin is tied to the AGND pin through a resistor less than 60.4 k $\Omega$ , the controller operates in continuous conduction mode (CCM) during light-load conditions. During CCM, the switching frequency maintained to an almost constant level over the entire load range, which is suitable for applications requiring tight control of the switching frequency.

### 7.4.3 Powering the Device From a 12-V Bus

Both TPSM8A28 and TPSM8A29 can be powered by a single 12-V bus. In this configuration, the internal LDO is powered by a 12-V bus and generates a 4.5-V output to bias the internal analog circuitry and also powers up the gate drives. The VIN range under this configuration for TPSM8A29 is 4 V to 16 V for up to 15-A load current. VIN range for TPSM8A28 is 3 V to 16 V for up to 12 A. 图 7-4 shows an example for this single VIN configuration.

VIN and EN are the two signals to enable the part. For a start-up sequence, any sequence between the VIN and EN signals can power the device up correctly.



图 7-4. Single VIN Configuration With 12-V Bus

### 7.4.4 Powering the Device From a 5.0-V Bus

The TPSM8A29 can deliver up to a 15-A load current when powering from a 5-V bus, 12 A for TPSM8A28. To make sure the internal analog circuitry and the gate drives are powered up properly, the VCC pin must be shorted to the VIN pins with a low impedance trace. A trace with at least 24-mil width is recommended. Due to the maximum rating limit on the VCC pin, the VIN input range under this configuration is 4.75 V to 5.3 V. The input voltage must stay higher than both VIN UVLO and VCC UVLO, otherwise the device shuts down immediately. 图 7-5 shows an example for this single VIN configuration.

VIN and EN are the two signals to enable the part. For start-up sequence, any sequence between the VIN and EN signals can power the device up correctly.

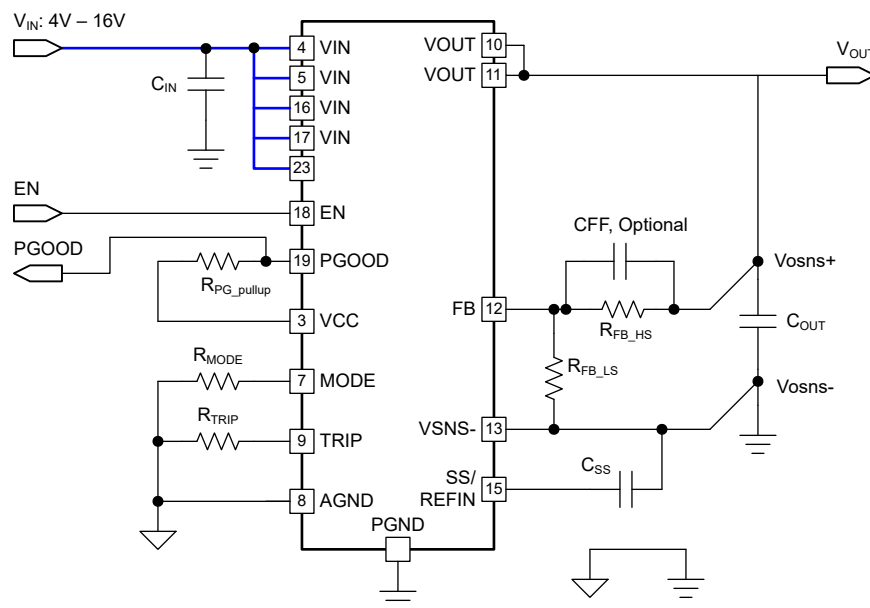
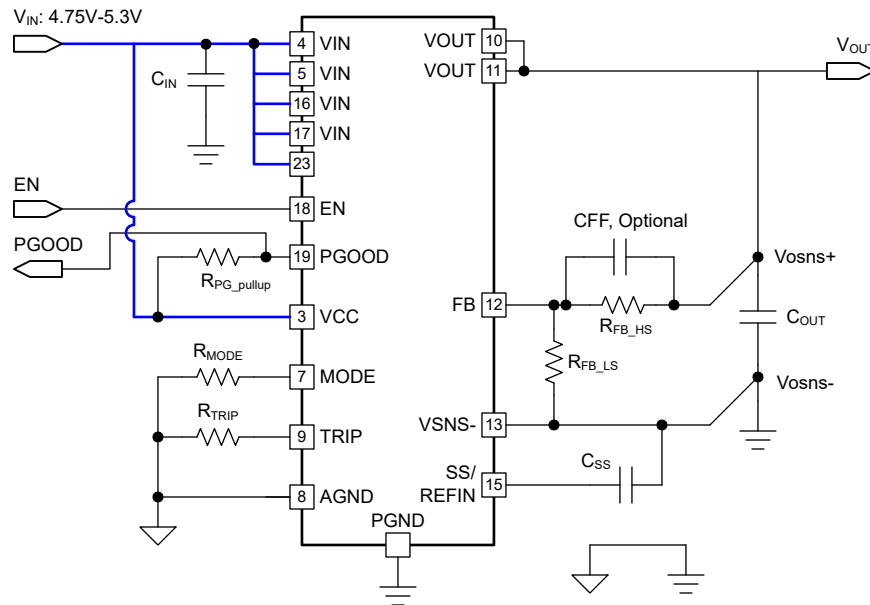

**图 7-5. Single VIN Configuration With 5.0-V Bus**

### 7.4.5 Powering the Device From a Split-Rail Configuration

The TPSM8A28 and TPSM8A29 devices can be configured to split-rail by using an independent power supply that applies a valid bias on to VCC pin. Connecting a valid VCC bias to the VCC pin overrides the internal LDO, thus saves power loss on that linear regulator and helps to improve overall system level efficiency. 5.0-V rail is the common choice as VCC bias. With a stable VCC bias, the VIN input range under this configuration can be as low as 2.7 V and up to 16 V for both TPSM8A28 and TPSM8A29.

图 7-6 shows an example for this split rail configuration.

The VCC external bias current during nominal operation varies with the bias voltage level and also the operating frequency. For example, by setting the device to Skip mode, the VCC pins decreases current draw from the external bias when the frequency decreases under light-load condition. The typical VCC external bias current under FCCM operation is listed in the Electrical Characteristics table to help the user prepare the capacity of the external bias.

Under split rail configuration, VIN, VCC bias, and EN are the signals to enable the part. For start-up sequence, it is recommended that at least one of VIN UVLO rising threshold and EN rising threshold is satisfied later than VCC UVLO rising threshold. A practical start-up sequence example is: VIN applied first, then the external bias applied, and then EN signal goes high.

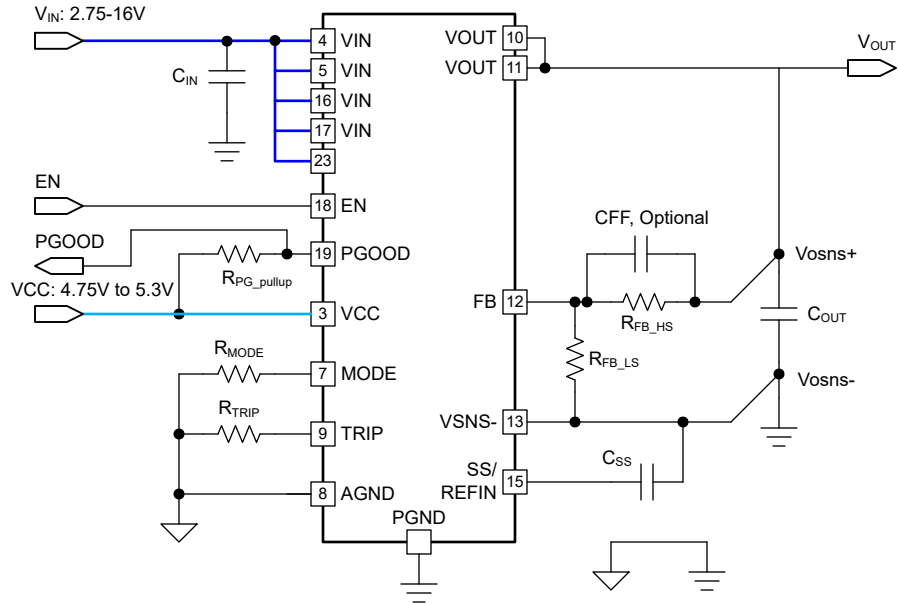

**图 7-6. Split Rail Configuration With External VCC Bias**

## 8 Application and Implementation

### 备注

以下应用部分中的信息不属于 TI 器件规格的范围，TI 不担保其准确性和完整性。TI 的客户应负责确定器件是否适用于其应用。客户应验证并测试其设计，以确保系统功能。

### 8.1 Application Information

The TPSM8A28 and TPSM8A29 power modules feature an integrated power inductor and some basic passives. The devices are small and highly efficient, suitable for low output voltage point-of-load applications up to 15 A. These devices features proprietary D-CAP3™ mode control combined with adaptive on-time architecture. This combination builds modern low-duty-ratio and ultra-fast load-step-response DC/DC converters in an ideal fashion. The output voltage ranges from 0.6 V to 5.5 V. The conversion input voltage ranges from 2.7 V to 16 V, and the VCC input voltage ranges from 4.75 V to 5.3 V. The D-CAP3™ control mode uses emulated current information to control the modulation. An advantage of this control scheme is that it does not require an external phase-compensation network, which makes the device easy to use and also allows for a low external component count. Another advantage of this control scheme is that it supports stable operation with all low-ESR output capacitors (such as ceramic capacitor and low-ESR polymer capacitor). Adaptive on-time control tracks the preset switching frequency over a wide range of input and output voltages while increasing switching frequency as needed during a load-step transient.

### 8.2 Typical Application

The schematic shows a typical application for the TPSM8A29. This example describes the design procedure of converting an input voltage range of 9.6 V to 14.4 V to a 1-V output, up to 15-A load current.



图 8-1. Application Circuit Diagram

## 8.2.1 Design Requirements

This design uses the parameters listed in 表 8-1. A switching frequency of 600 kHz was chosen to maximize efficiency. See 表 7-1 for all switching frequency and operating mode configurations.

**表 8-1. Design Example Specifications**

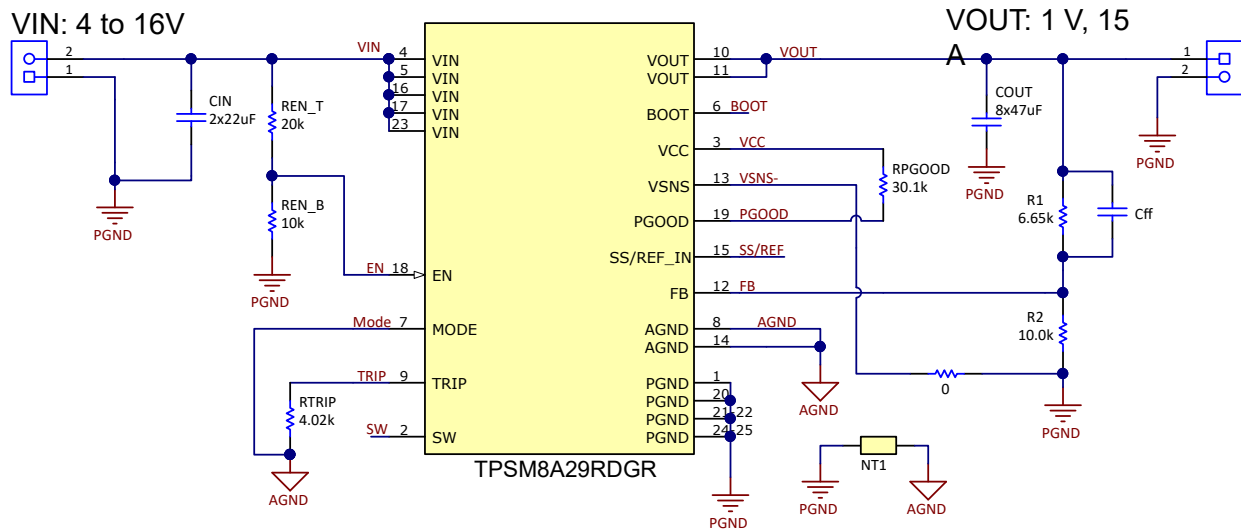
DESIGN PARAMETER	CONDITION	MIN	TYP	MAX	UNIT
V <sub>IN</sub>	Voltage range	9.6	12	14.4	V
V <sub>OUT</sub>	Output voltage		1.0		V
I <sub>LOAD</sub>	Output load current			15	A
V <sub>RIPPLE</sub>	Output voltage ripple	V <sub>IN</sub> = 12 V, I <sub>OUT</sub> = 15 A			mV <sub>PP</sub>
V <sub>TRANS</sub>	Output voltage undershoot and overshoot after load step	I <sub>OUT</sub> = 50% to 100% step, 5 A/μs slew rate			mV
I <sub>OVER</sub>	Output overcurrent		15		A
t <sub>SS</sub>	Soft-start time		1.5		ms
f <sub>SW</sub>	Switching frequency		600		kHz
	Operating mode		FCCM		
T <sub>A</sub>	Operating temperature		25		°C

## 8.2.2 Detailed Design Procedure

The external component selection is a simple process using D-CAP3™ mode. Select the external components using the following steps.

### 8.2.2.1 Output Voltage Setting Point

The output voltage is programmed by the voltage-divider resistors, R1 and R2, shown in 方程式 7. Connect R1 between the FB pin and the output, and connect R2 between the FB pin and VSNS -. The recommended R2 value is 10 kΩ, but it can also be set to another value between the range of 1 kΩ to 20 kΩ. Determine R1 by using 方程式 7. For 1.0 V<sub>OUT</sub>, a value of 6.65 kΩ is chosen.

$$R1 = \frac{V_{OUT} - V_{INTREF}}{V_{INTREF}} \times R2 = \frac{1V - 0.6V}{0.6V} \times 10k\Omega = 6.65k\Omega \quad (7)$$

### 8.2.2.2 Choose the Inductor

An optimized 0.6-μH inductor is integrated inside the module.

### 8.2.2.3 Set the Current Limit (TRIP)

The R<sub>TRIP</sub> resistor sets the valley current limit. 方程式 8 calculates the recommended current limit target. 方程式 9 calculates the R<sub>TRIP</sub> resistor to set the current limit. The typical valley current limit target is 15.0 A, and the closest standard value for R<sub>TRIP</sub> is 4.02 kΩ.

$$I_{LIMVALLEY} = I_{OUT} - \frac{1}{2} \times \frac{(V_{IN(MIN)} - V_{OUT}) \times V_{OUT}}{0.6\mu H \times V_{IN(MIN)} \times f_{sw}} = 15A - \frac{1}{2} \times \frac{(9.6V - 1V) \times 1V}{0.6\mu H \times 9.6V \times 600kHz} = 13.756A \quad (8)$$

$$R_{TRIP} = \frac{60000}{I_{LIMVALLEY}} = \frac{60000}{15A} = 4.0k\Omega \quad (9)$$

With the current limit set, 方程式 10 calculates the typical maximum output current at current limit. 方程式 11 calculates the typical peak current at current limit. For worst case calculations, the tolerance of the inductance (20%) and the current limit must be included.

$$I_{OUTLIM} = I_{LIMVALLEY} - \frac{1}{2} \times \frac{(V_{IN(MIN)} - V_{OUT}) \times V_{OUT}}{0.6\mu H \times V_{IN(MIN)} \times f_{sw}} = 15A - \frac{1}{2} \times \frac{(9.6V - 1V) \times 1V}{0.6\mu H \times 9.6V \times 600kHz} = 16.24A \quad (10)$$

$$I_{L(\text{PEAK})} = I_{\text{LIMVALLEY}} - \frac{1}{2} \times \frac{(V_{\text{IN}(\text{MAX})} - V_{\text{OUT}}) \times V_{\text{OUT}}}{0.6 \mu\text{H} \times V_{\text{IN}(\text{MAX})} \times f_{\text{sw}}} = 15 \text{ A} - \frac{1}{2} \times \frac{(14.4 \text{ V} - 1 \text{ V}) \times 1 \text{ V}}{0.6 \mu\text{H} \times 14.4 \text{ V} \times 600 \text{ kHz}} = 16.29 \text{ A} \quad (11)$$

### 8.2.2.4 Choose the Output Capacitor

There are three considerations for selecting the value of the output capacitor.

1. Stability
2. Steady state output voltage ripple
3. Regulator transient response to a change load current

First, the minimum output capacitance must be calculated based on these three requirements. 方程式 12 calculates the minimum capacitance to keep the LC double pole below 1/30th the  $f_{\text{sw}}$  to meet stability requirements. This requirement helps to keep the LC double pole close to the internal zero.

$$C_{\text{OUT\_STABILITY}} > \left(\frac{30}{2\pi \times f_{\text{sw}}}\right)^2 \times \frac{1}{0.6 \mu\text{H}} = \left(\frac{30}{2\pi \times 600 \text{ kHz}}\right)^2 \times \frac{1}{0.6 \mu\text{H}} = 105.5 \mu\text{F} \quad (12)$$

$$C_{\text{OUT\_RIPPLE}} > \frac{\left(\frac{V_{\text{IN}(\text{MAX})} - V_{\text{out}}}{V_{\text{IN}(\text{MAX})}}\right) \times \left(\frac{V_{\text{out}}}{0.6 \mu\text{H} \times f_{\text{sw}}}\right)}{8 \times V_{\text{ripple}} \times f_{\text{sw}}} = \frac{\left(\frac{14.4 \text{ V} - 1 \text{ V}}{14.4 \text{ V}}\right) \times \left(\frac{1 \text{ V}}{0.6 \mu\text{H} \times 600 \text{ kHz}}\right)}{8 \times 10 \text{ mV} \times 600 \text{ kHz}} = 53.8 \mu\text{F} \quad (13)$$

方程式 13 calculates the minimum capacitance to meet the steady state output voltage ripple requirement of 10 mV. This calculation is for FCCM operation and does not include the portion of the output voltage ripple caused by the ESR or ESL of the output capacitors. 方程式 14 and 方程式 15 calculate the minimum capacitance to meet the transient response requirement of  $\pm 50$  mV for a 7.5-A step. These equations calculate the necessary output capacitance to hold the output voltage steady while the inductor current ramps up or ramps down after a load step.

$$C_{\text{OUT\_UNDERSHOOT}} > \frac{0.6 \mu\text{H} \times I_{\text{STEP}}^2 \times \left(\frac{V_{\text{out}}}{V_{\text{IN}(\text{MIN})} \times f_{\text{sw}} + t_{\text{off}}}\right)}{2 \times V_{\text{TRANS}} \times V_{\text{OUT}} \times \left(\frac{V_{\text{IN}(\text{MIN})} - V_{\text{OUT}}}{V_{\text{IN}(\text{MIN})} \times f_{\text{sw}} - t_{\text{off}}}\right)} = \frac{0.6 \mu\text{H} \times 7.5^2 \times \left(\frac{1 \text{ V}}{9.6 \text{ V} \times 600 \text{ kHz} + 220 \text{ ns}}\right)}{2 \times 50 \text{ mV} \times 1 \text{ V} \times \left(\frac{9.6 \text{ V} - 1 \text{ V}}{9.6 \text{ V} \times 600 \text{ kHz} - 220 \text{ ns}}\right)} \quad (14)$$

$$= 104.4 \mu\text{F}$$

$$C_{\text{OUT\_OVERSHOOT}} > \frac{0.6 \mu\text{H} \times I_{\text{STEP}}^2}{2 \times V_{\text{TRANS}} \times V_{\text{OUT}}} = \frac{0.6 \mu\text{H} \times 7.5^2}{2 \times 50 \text{ mV} \times 1 \text{ V}} = 337.5 \mu\text{F} \quad (15)$$

The output capacitance needed to meet the overshoot requirement is the highest value, so this sets the required minimum output capacitance for this example. Stability requirements can also limit the maximum output capacitance. 方程式 16 calculates the recommended maximum output capacitance. This calculation keeps the LC double pole above 1/100th the  $f_{\text{sw}}$ . It can be possible to use more output capacitance but the stability must be checked through a bode plot or transient response measurement. The selected output capacitance is  $8 \times 47\text{-}\mu\text{F}$  ceramic capacitors. When using ceramic capacitors, the capacitance must be derated due to DC and AC bias effects. The selected capacitors derate to approximately 95% of their nominal value giving an effective total capacitance of approximately 357  $\mu\text{F}$ . This effective capacitance meets the minimum and maximum requirements.

$$C_{\text{OUT\_STABILITY}} < \left(\frac{50}{\pi \times f_{\text{sw}}}\right)^2 \times \frac{1}{0.6 \mu\text{H}} = \left(\frac{50}{\pi \times 600 \text{ kHz}}\right)^2 \times \frac{1}{0.6 \mu\text{H}} = 1172.7 \mu\text{F} \quad (16)$$

This application uses all ceramic capacitors so the effects of ESR on the ripple and transient were ignored. If using non-ceramic capacitors, as a starting point, the ESR must be below the values calculated in 方程式 17 to meet the ripple requirement and 方程式 18 to meet the transient requirement. For more accurate calculations or if using mixed output capacitors, the impedance of the output capacitors must be used to determine if the ripple and transient requirements can be met.



$$R_{ESR\_RIPPLE} < \frac{V_{RIPPLE}}{\left(\frac{V_{IN(MAX)} - V_{out}}{V_{IN(MAX)}}\right) \times \left(\frac{V_{out}}{0.6 \mu\text{H} \times f_{sw}}\right)} = \frac{10 \text{ mV}}{\left(\frac{14.4 \text{ V} - 1 \text{ V}}{14.4 \text{ V}}\right) \times \left(\frac{1 \text{ V}}{0.6 \mu\text{H} \times 600 \text{ kHz}}\right)} = 3.86 \text{ m}\Omega \quad (17)$$

$$R_{ESR\_TRANS} < \frac{V_{TRANS}}{I_{STEP}} = \frac{50 \text{ mV}}{7.5 \text{ A}} = 6.67 \text{ m}\Omega \quad (18)$$

### 8.2.2.5 Choose the Input Capacitors ( $C_{IN}$ )

The device requires input bypass capacitors between the VIN and PGND pins to bypass the power stage. The bypass capacitors must be placed as close as possible to the pins of the IC as the layout will allow. At least 10- $\mu\text{F}$  of ceramic capacitance is required. Two 0.1- $\mu\text{F}$  and one 1-nF capacitors are integrated inside to the module package, eliminating the need for typical high frequency bypass capacitors. However, they can be used if desired. The high frequency bypass capacitors minimizes high frequency voltage overshoot across the power-stage. The ceramic capacitors must be high-quality dielectric of X6S or better for their high capacitance-to-volume ratio and stable characteristics across temperature. In addition to this, more bulk capacitance can be needed on the input depending on the application to minimize variations on the input voltage during transient conditions.

The input capacitance required to meet a specific input ripple target can be calculated with [方程式 19](#). A recommended target input voltage ripple is 5% the minimum input voltage, 480 mV in this example. The calculated input capacitance is 4.86  $\mu\text{F}$ , and the minimum input capacitance of 10  $\mu\text{F}$  exceeds this. This example meets these two requirements with 2  $\times$  22- $\mu\text{F}$  ceramic capacitors. An input capacitor must be used on both sides of the module during layout, close to pins 5 and 16.

$$C_{IN} > \frac{V_{out} \times I_{out} \times \left(1 - \frac{V_{out}}{V_{IN(MIN)}}\right)}{f_{sw} \times V_{IN(MIN)} \times V_{IN\_RIPPLE}} = \frac{1 \text{ V} \times 15 \text{ A} \times \left(1 - \frac{1 \text{ V}}{9.6 \text{ V}}\right)}{600 \text{ kHz} \times 9.6 \text{ V} \times 480 \text{ mV}} = 4.86 \mu\text{F} \quad (19)$$

The capacitor must also have an RMS current rating greater than the maximum input RMS current in the application. The input RMS current the input capacitors must support is calculated by [方程式 20](#) and is 4.588 A in this example. The ceramic input capacitors have a current rating greater than this.

$$I_{CIN(RMS)} = \sqrt{\frac{V_{out}}{V_{IN(MIN)}} \times \left( \left(\frac{V_{IN(MIN)} - V_{out}}{V_{IN(MIN)}}\right) \times I_{OUT}^2 + \frac{\left(\left(\frac{V_{IN(MIN)} - V_{out}}{V_{IN(MIN)}}\right) \times \left(\frac{V_{out}}{0.6 \mu\text{H} \times f_{sw}}\right)\right)^2}{12} \right)} = \quad (20)$$

$$I_{CIN(RMS)} = \sqrt{\frac{1 \text{ V}}{9.6 \text{ V}} \times \left( \left(\frac{9.6 \text{ V} - 1 \text{ V}}{9.6 \text{ V}}\right) \times 15 \text{ A}^2 + \frac{\left(\left(\frac{9.6 \text{ V} - 1 \text{ V}}{9.6 \text{ V}}\right) \times \left(\frac{1 \text{ V}}{0.6 \mu\text{H} \times 600 \text{ kHz}}\right)\right)^2}{12} \right)} = 4.588 \text{ A} \quad (21)$$

For applications requiring bulk capacitance on the input, such as ones with low input voltage and high current, the selection process in [this article](#) is recommended.

### 8.2.2.6 Soft-Start Capacitor (SS/REFIN Pin)

The capacitor placed on the SS/REFIN pin can be used to extend the soft-start time past the internal 1.5-ms soft start. The required external capacitance can be calculated with [方程式 2](#). The module incorporates a 1-nF capacitor between the SS/REFIN pin and VSNS-. This example uses a minimum default soft-start time of 1.5 ms.

### 8.2.2.7 EN Pin Resistor Divider

A resistor divider on the EN pin can be used to increase the input voltage the converter begins its startup sequence. To set the start voltage, first select the bottom resistor ( $R_{EN\_B}$ ). The recommended value is between 1 k $\Omega$  and 100 k $\Omega$ . There is an internal pulldown resistance with a nominal value of 6 M $\Omega$ . This must be included for the most accurate calculations. This is especially important when the bottom resistor is a higher value, near

100 k $\Omega$ . This example uses a 10-k $\Omega$  resistor and this combined with the internal resistance in parallel results in an equivalent bottom resistance of 9.98 k $\Omega$ . The top resistor value for the target start voltage is calculated with 方程式 22. In this example, the nearest standard value of 20 k $\Omega$  is selected for R<sub>EN\_T</sub>. When selecting a start voltage in a wide input range application, be cautious that the EN pin absolute maximum voltage of 6 V is not exceeded.

$$R_{EN\_T} = \frac{R_{EN\_B} \times V_{start}}{V_{ENH}} - R_{EN\_B} = \frac{10 \text{ k}\Omega \times 3.7 \text{ V}}{1.22 \text{ V}} - 10 \text{ k}\Omega = 20 \text{ k}\Omega \quad (22)$$

The start and stop voltages with the selected EN resistor divider can be calculated with 方程式 23 and 方程式 24, respectively.

$$V_{start} = V_{ENH} \times \frac{R_{EN\_T} + R_{EN\_B}}{R_{EN\_B}} = 1.22 \text{ V} \times \frac{20 \text{ k}\Omega + 10 \text{ k}\Omega}{10 \text{ k}\Omega} = 3.66 \text{ V} \quad (23)$$

$$V_{stop} = V_{ENL} \times \frac{R_{EN\_T} + R_{EN\_B}}{R_{EN\_B}} = 1.02 \text{ V} \times \frac{20 \text{ k}\Omega + 10 \text{ k}\Omega}{10 \text{ k}\Omega} = 3.06 \text{ V} \quad (24)$$

### 8.2.2.8 VCC Bypass Capacitor

A 1.0- $\mu$ F bypass capacitor is integrated inside the module. No external bypass is required.

### 8.2.2.9 BOOT Capacitor

A 0.1- $\mu$ F boot capacitor is integrated inside the module, no additional boot capacitor is necessary.

### 8.2.2.10 PGOOD Pullup Resistor

The PGOOD pin is open-drain so a pullup resistor is required when using this pin. The recommended value is between 1 k $\Omega$  and 100 k $\Omega$ .

## 8.2.3 Application Curves

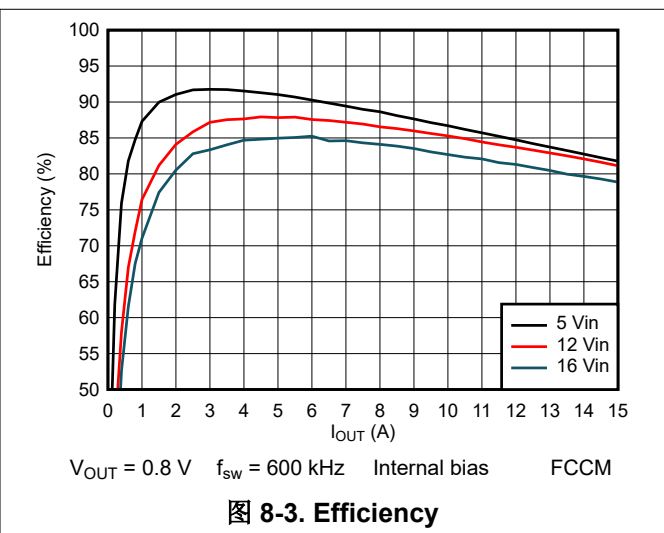
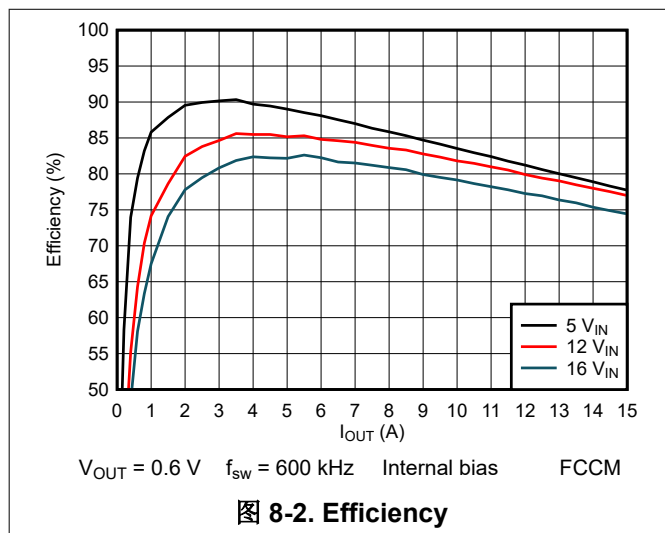

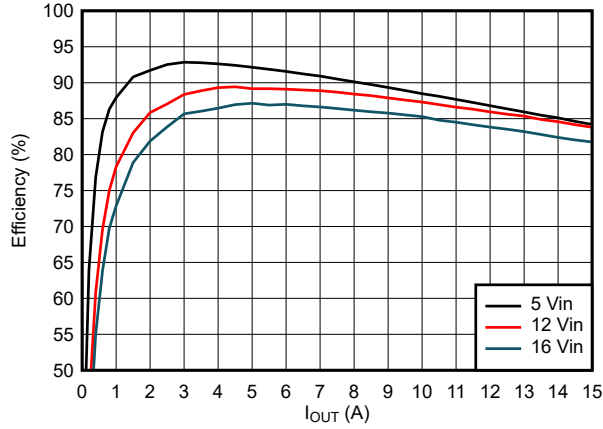

$V_{OUT} = 1.0\text{ V}$   $f_{sw} = 600\text{ kHz}$  Internal bias FCCM

图 8-4. Efficiency

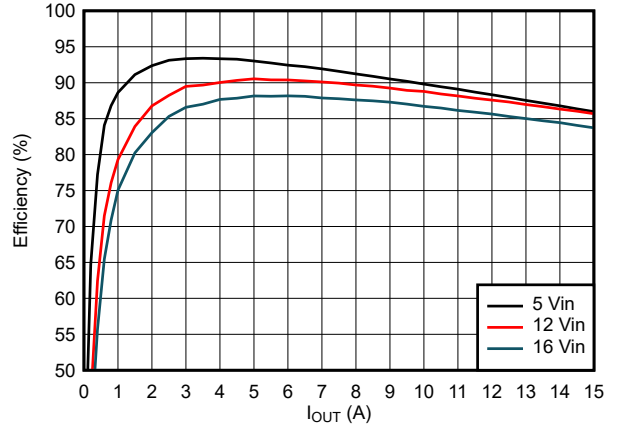

$V_{OUT} = 1.2\text{ V}$   $f_{sw} = 600\text{ kHz}$  Internal bias FCCM

图 8-5. Efficiency

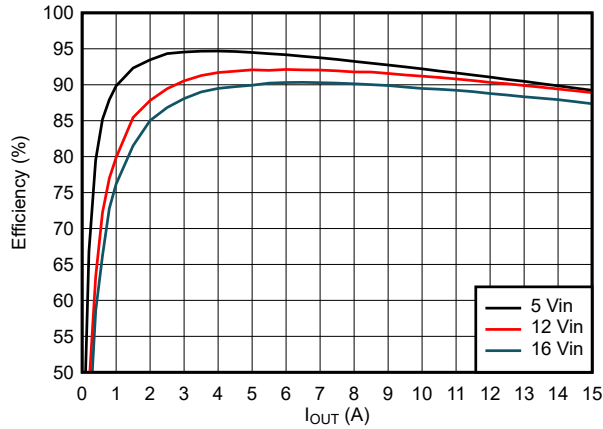

$V_{OUT} = 1.8\text{ V}$   $f_{sw} = 600\text{ kHz}$  Internal bias FCCM

图 8-6. Efficiency

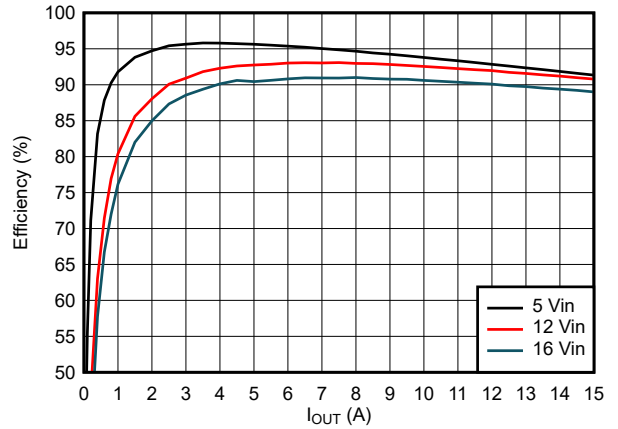

$V_{OUT} = 2.5\text{ V}$   $f_{sw} = 600\text{ kHz}$  Internal bias FCCM

图 8-7. Efficiency

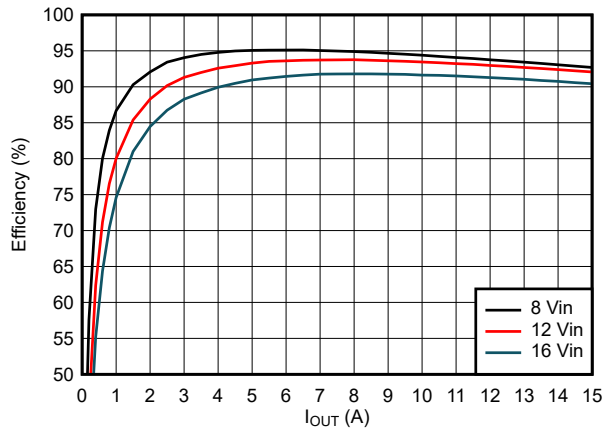

$V_{OUT} = 3.3\text{ V}$   $f_{sw} = 600\text{ kHz}$  Internal bias FCCM

图 8-8. Efficiency

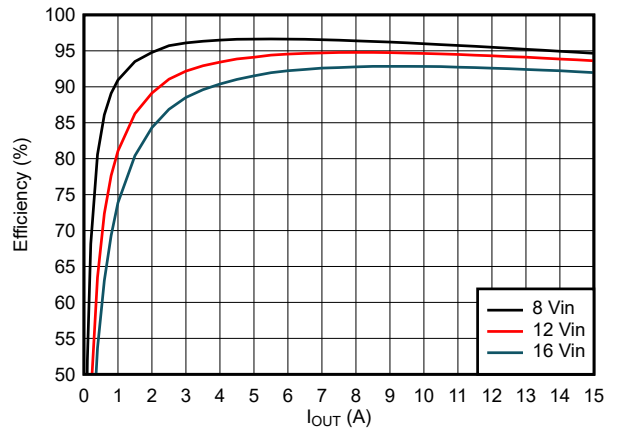

$V_{OUT} = 5\text{ V}$   $f_{sw} = 600\text{ kHz}$  Internal bias FCCM

图 8-9. Efficiency

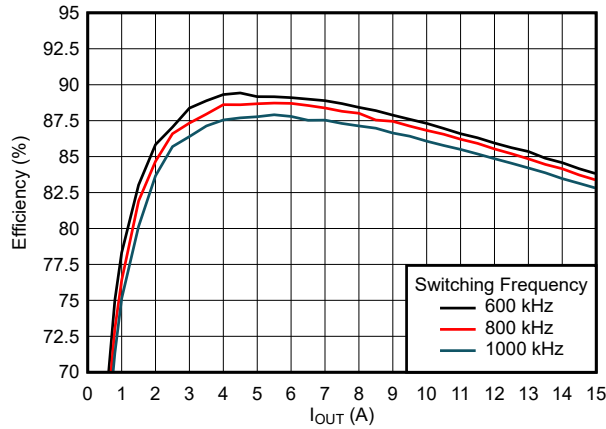

$V_{IN} = 12\text{ V}$   $V_{OUT} = 1\text{ V}$  Internal bias FCCM

图 8-10. Efficiency

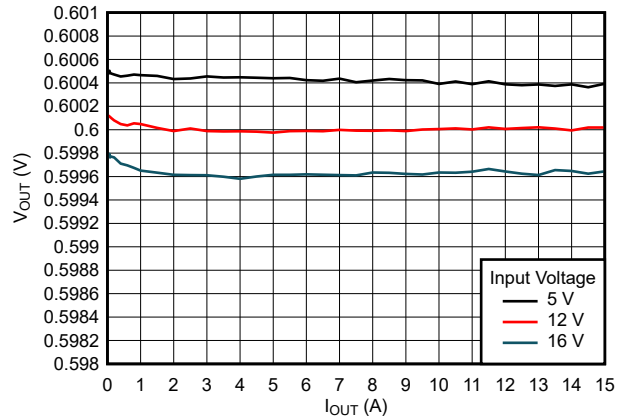

$V_{OUT} = 0.6\text{ V}$   $f_{SW} = 600\text{ kHz}$  Internal bias FCCM

图 8-11. Load Regulation

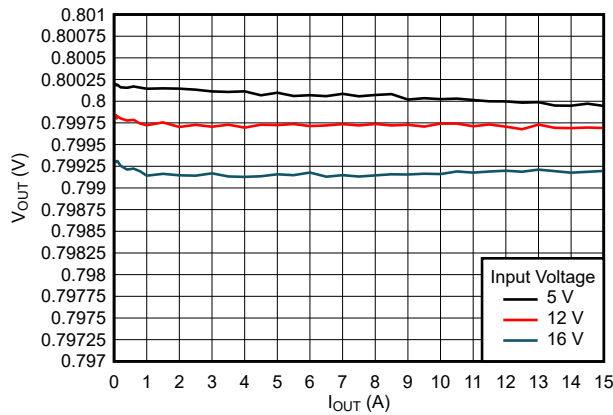

$V_{OUT} = 0.8\text{ V}$   $f_{SW} = 600\text{ kHz}$  Internal bias FCCM

图 8-12. Load Regulation

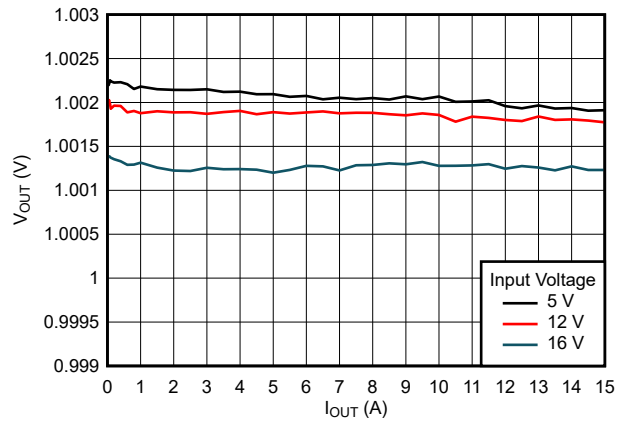

$V_{OUT} = 1.0\text{ V}$   $f_{SW} = 600\text{ kHz}$  Internal bias FCCM

图 8-13. Load Regulation

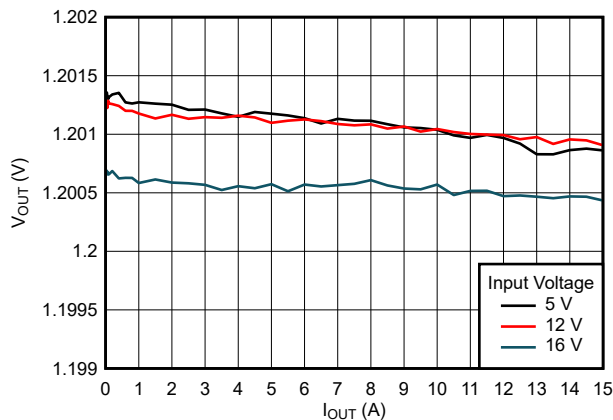

$V_{OUT} = 1.2\text{ V}$   $f_{SW} = 600\text{ kHz}$  Internal bias FCCM

图 8-14. Load Regulation

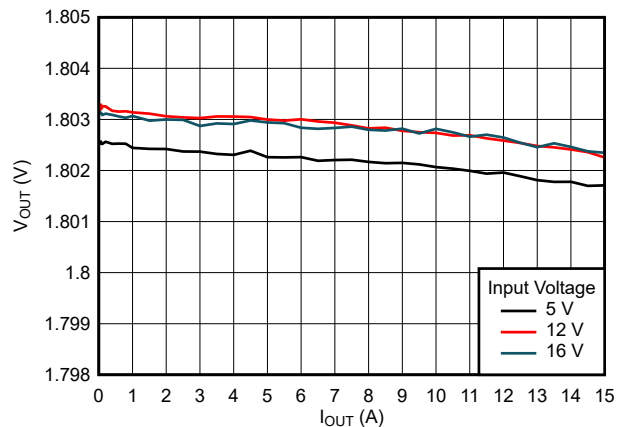

$V_{OUT} = 1.8\text{ V}$   $f_{SW} = 600\text{ kHz}$  Internal bias FCCM

图 8-15. Load Regulation



图 8-16. Load Regulation



图 8-17. Load Regulation

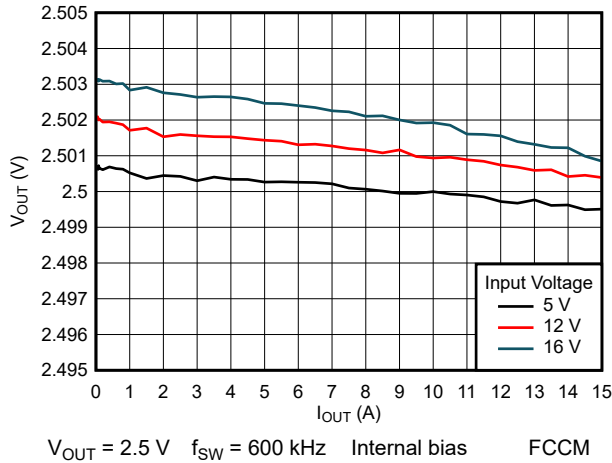

图 8-18. Load Regulation

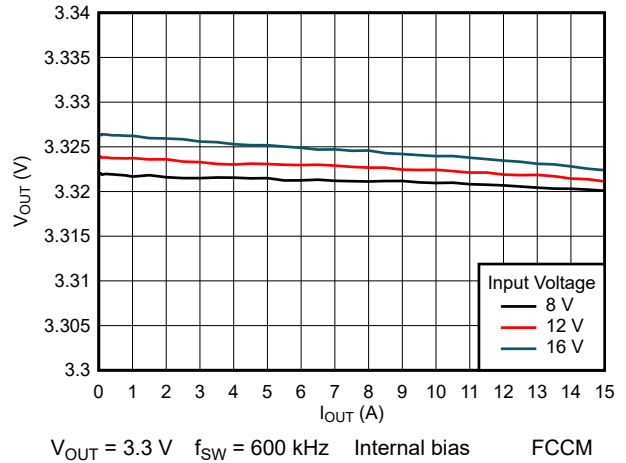

图 8-19. Line Regulation

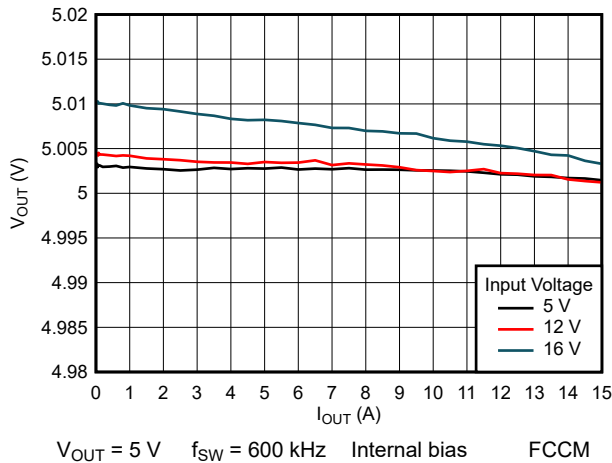

图 8-20. Switching Frequency

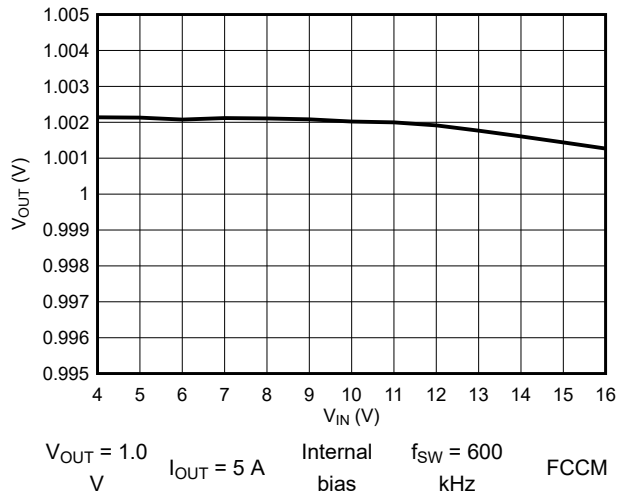

图 8-21. Switching Frequency

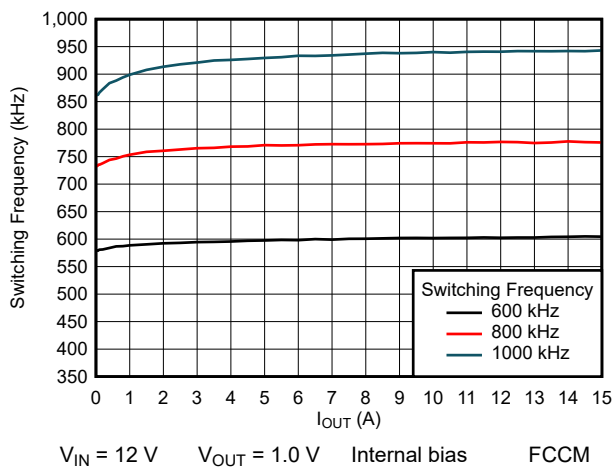

图 8-22. Switching Frequency

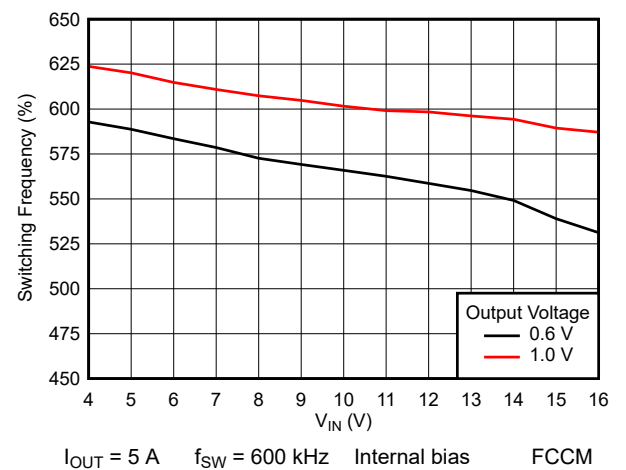

图 8-23. Switching Frequency

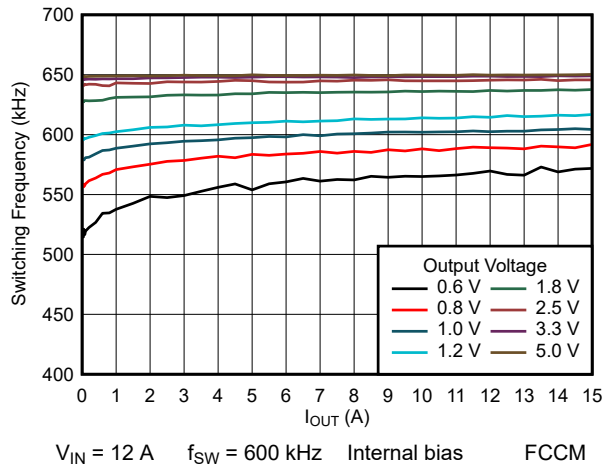

图 8-24. Switching Frequency

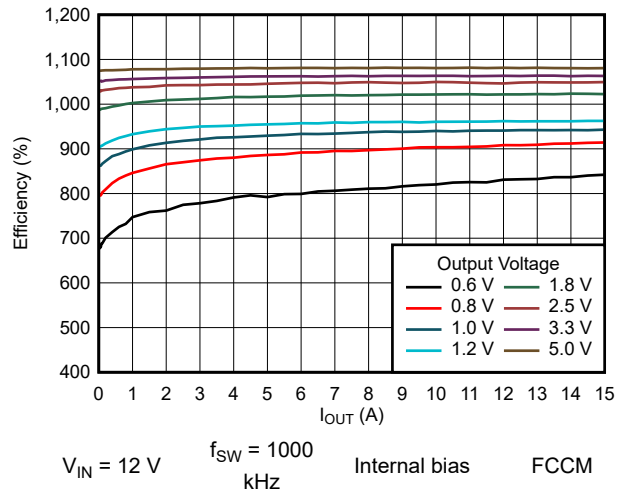

图 8-25. Switching Frequency

In the following images, all measurements taken with  $V_{IN} = 12\text{ V}$ ,  $V_{OUT} = 1\text{ V}$ ,  $f_{SW} = 600\text{ kHz}$ , internal bias,  $T_{AMB} = 25^\circ\text{C}$

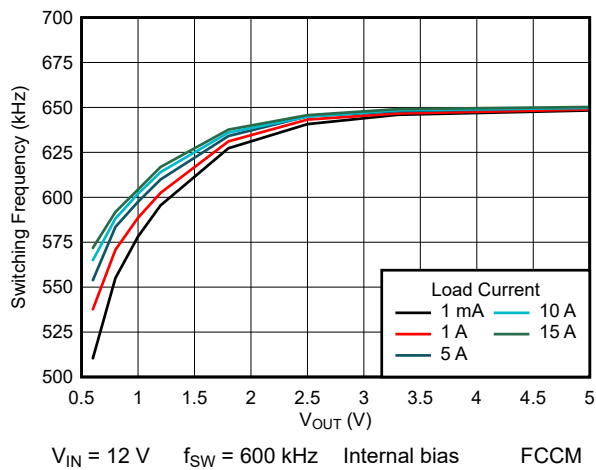

图 8-26. Output Voltage Ripple,  $V_{RIPPLE} = 6.4\text{ mV}$

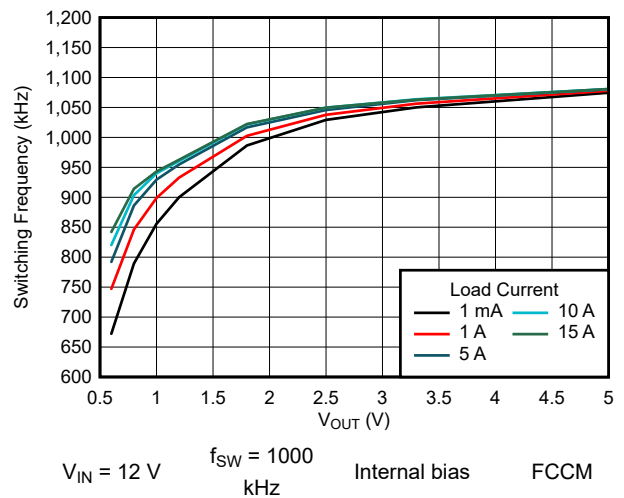

图 8-27. Output Voltage Ripple,  $V_{RIPPLE} = 7.6\text{ mV}$

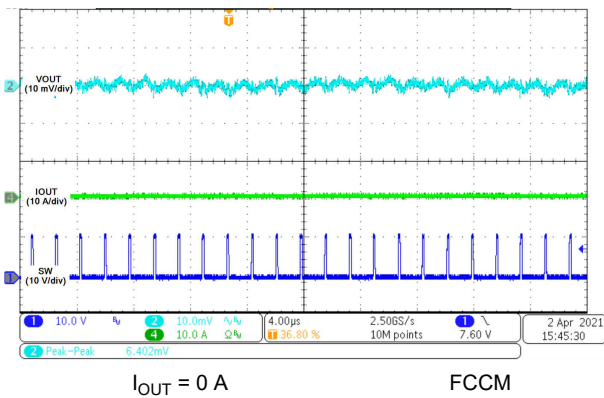

图 8-28. Output Voltage Ripple,  $V_{RIPPLE} = 20.3 \text{ mV}$

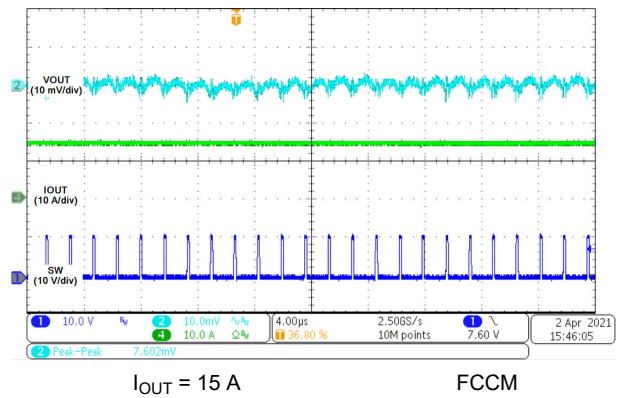

图 8-29. Output Voltage Ripple,  $V_{RIPPLE} = 10.4 \text{ mV}$

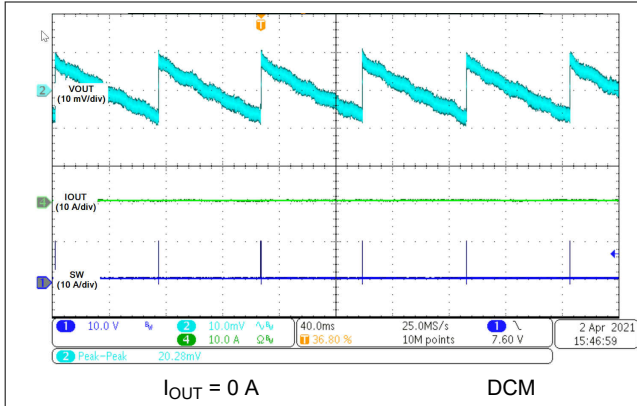

图 8-30. Output Voltage Ripple,  $V_{RIPPLE} = 8.8 \text{ mV}$

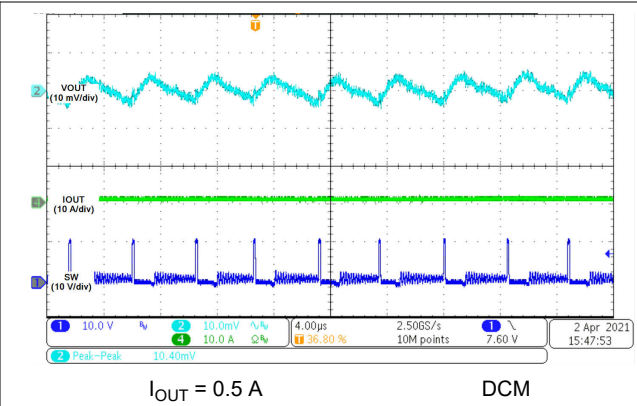

图 8-31. Startup Through  $V_{IN}$  (Enable Floating)

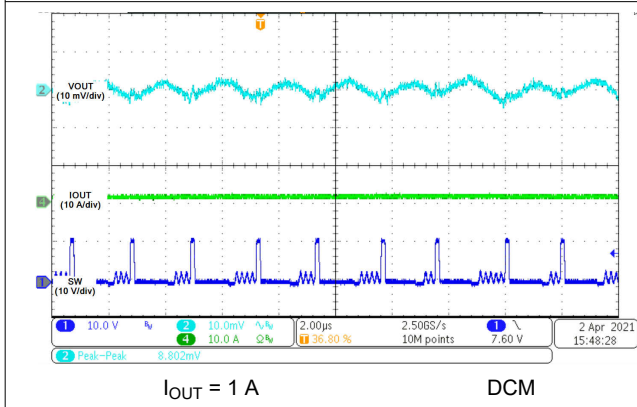

图 8-32. Startup Through  $V_{IN}$  (Enable Floating)

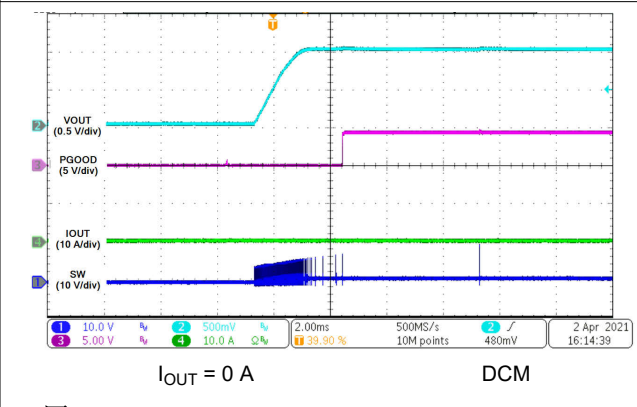

图 8-33. Startup Through Enable

**TPSM8A28, TPSM8A29**

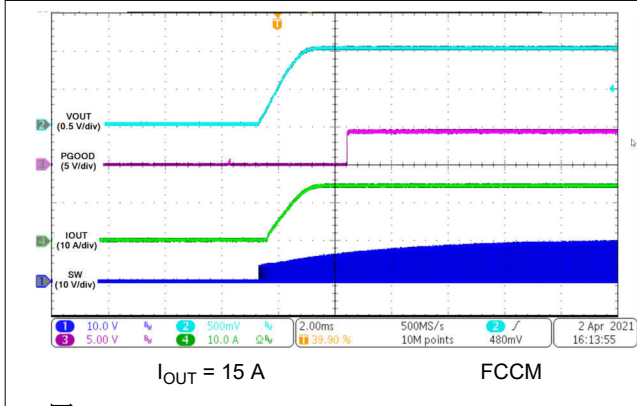
ZHCS007A - AUGUST 2021 - REVISED NOVEMBER 2021

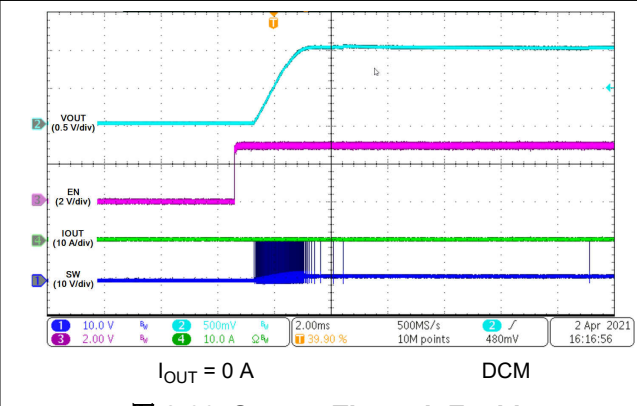
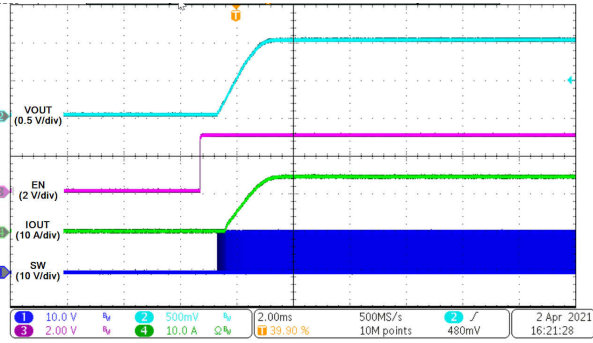

$I_{OUT} = 15\text{ A}$  FCCM

**图 8-34. Startup Through Enable**

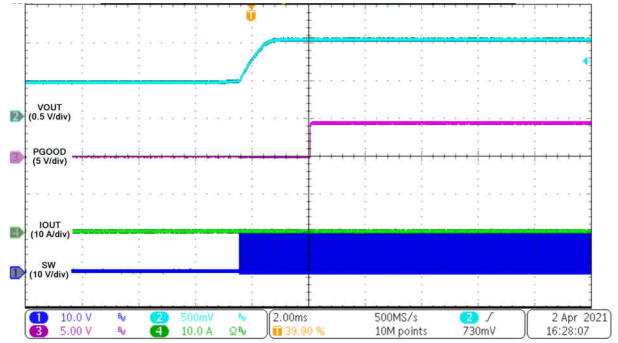

$I_{OUT} = 0\text{ A}$  FCCM

**图 8-35. Startup Through Enable into Prebiased Load**

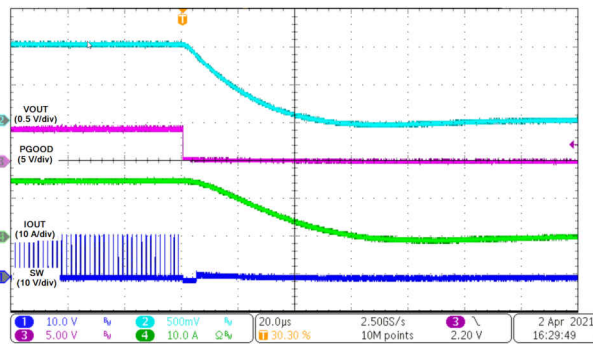

$I_{OUT} = 15\text{ A}$  FCCM

**图 8-36. Shutdown Through Enable**

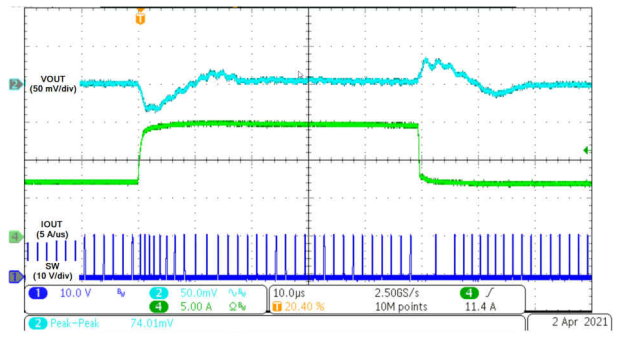

$I_{STEP} = 7.5\text{ A} - 15\text{ A} - 7.5\text{ A}$   $5\text{ A}/\mu\text{s}$

**图 8-37. Transient Response,  $V_{PP} = 74\text{ mV}$**



## 9 Power Supply Recommendations

The devices are designed to operate from a wide input voltage supply range between 2.7 V and 16 V when the VCC pin is powered by an external bias ranging from 4.75 V to 5.3 V. Both input supplies (VIN and VCC bias) must be well regulated. Proper bypassing of input supplies (VIN and VCC bias) is also critical for noise performance, as are PCB layout and grounding scheme. See the recommendations in [节 10](#).

## 10 Layout

### 10.1 Layout Guidelines

Before beginning a design using one of the devices, consider the following:

- Place the input and output capacitors on the top side of the PCB. In order to shield and isolate the small signal traces from noisy power lines, insert at least one solid ground inner plane.
- At least thirteen PGND vias are required to be placed as close as possible to the PGND pins (pins 1, 20, 21, 22, 24, and 25). This minimizes parasitic impedance and also lowers thermal resistance.
- Always place the feedback resistors near the device to minimize the FB trace distance, no matter single-end sensing or remote sensing.
  - For remote sensing, the connections from the FB voltage divider resistors to the remote location should be a pair of PCB traces with at least 12-mil trace width, and should implement Kelvin sensing across a high bypass capacitor of 0.1  $\mu$ F or higher. The ground connection of the remote sensing signal must be connected to the VSNS – pin. The  $V_{OUT}$  connection of the remote sensing signal must be connected to the feedback resistor divider with the lower feedback resistor terminated at the VSNS – pin. To maintain stable output voltage and minimize the ripple, the pair of remote sensing lines should stay away from any noise sources such as inductor and SW nodes, or high frequency clock lines. And it is recommended to shield the pair of remote sensing lines with ground planes above and below.
  - For single-end sensing, connect the higher FB resistor to a high-frequency local bypass capacitor of 0.1- $\mu$ F or higher, and short VSNS – to AGND with shortest trace.
- Pin 8 (AGND pin) must be connected to a solid PGND plane at a single point. Use the common AGND via to connect the TRIP and MODE resistors to the inner ground plane if applicable. Pin 14 is also an AGND pin, and is connected internally to pin 8. No external connection between pins 8 and 14 is required, however, pin 8 must be used as the AGND connection.
- See [Figure 10-1](#) for the layout recommendation.

### 10.2 Layout Example



图 10-1. Recommended Layout Top Side



图 10-2. Recommended Layout Bottom Side

#### 10.2.1 Thermal Performance on the TI EVM

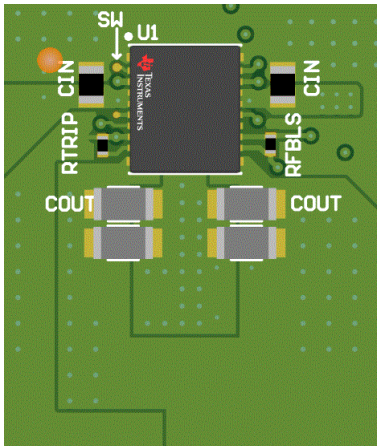
Test conditions:  $f_{SW} = 600$  kHz,  $V_{IN} = 12$  V,  $V_{OUT} = 1$  V,  $I_{OUT} = 15$  A,  $C_{OUT} = 8 \times 47$   $\mu$ F (1206/6.3V/X7R), IC: 82.5°C

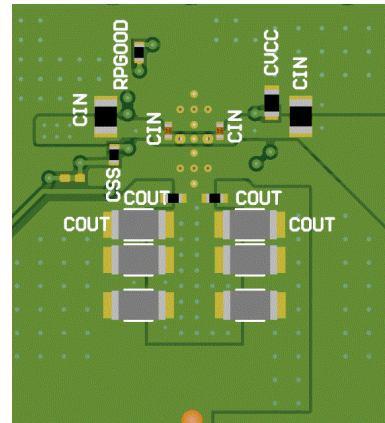

图 10-3. Thermal Image at 25°C Ambient, 12 Vin, 1 Vout, 15 A, 600 kHz

Test conditions:

$f_{SW} = 600 \text{ kHz}$ ,  $V_{IN} = 12 \text{ V}$ ,  $V_{OUT} = 5 \text{ V}$ ,  $I_{OUT} = 12 \text{ A}$ ,  $C_{OUT} = 8 \times 47 \mu\text{F}$  (1206/6.3V/X7R)

IC: 88.7°C

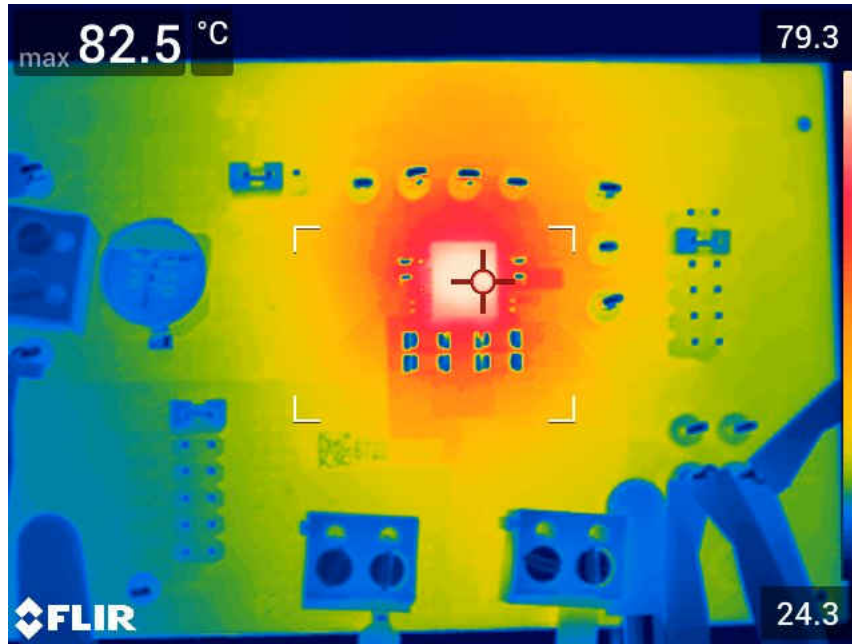

图 10-4. Thermal Image at 25°C Ambient, 12 Vin, 5 Vout, 12 A, 600 kHz

### 10.3 EMI

The TPSM8A28 and TPSM8A29 are compliant with EN55011 Class-A radiated emissions. [Figure 11-1](#) and [Figure 11-2](#) show examples of radiated emissions plots. The graphs include the plots of the antenna in the horizontal and vertical positions.

**TPSM8A28, TPSM8A29**

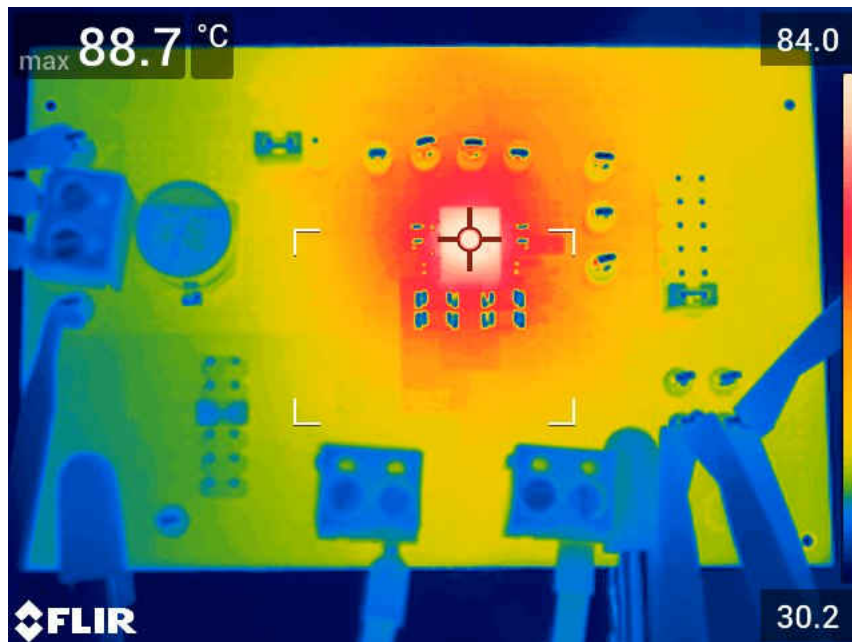
ZHCS007A - AUGUST 2021 - REVISED NOVEMBER 2021

The EMI plots were measured using the standard TPSM8A29EVM with Ferrite 61 type beads on the input wire.

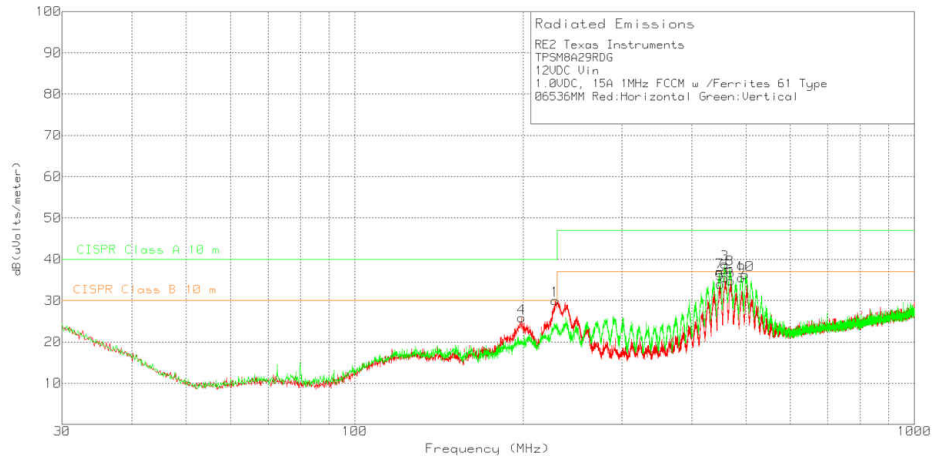

**图 10-5. Radiated Emissions 12-V Input, 1.0-V Outputs, 15-A/Output Load**

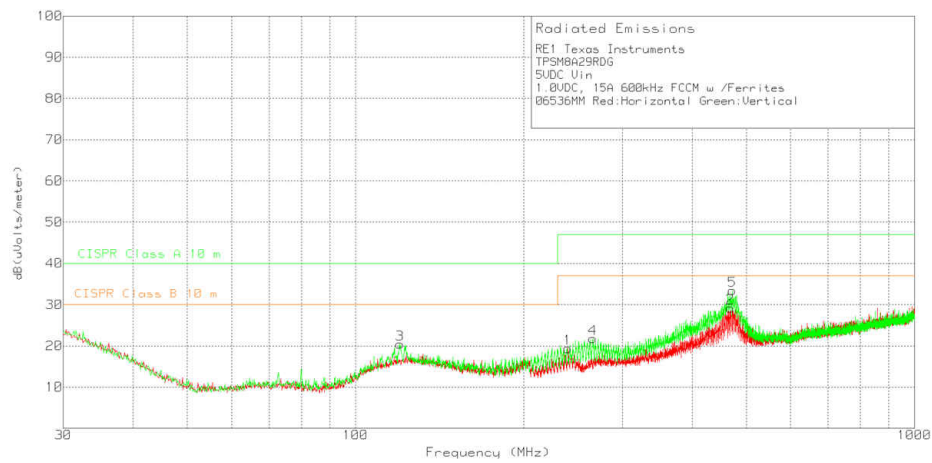

**图 10-6. Radiated Emissions 5-V Input, 1-V Output, 15-A/Output Load**

## 11 Device and Documentation Support

### 11.1 Device Support

#### 11.1.1 第三方产品免责声明

TI 发布的与第三方产品或服务有关的信息，不能构成与此类产品或服务或保修的适用性有关的认可，不能构成此类产品或服务单独或与任何 TI 产品或服务一起的表示或认可。

### 11.2 Documentation Support

#### 11.2.1 Related Documentation

[Optimizing Transient Response of Internally Compensated dc-dc Converters With Feedforward Capacitor Application Report](#)

### 11.3 接收文档更新通知

要接收文档更新通知，请导航至 [ti.com](http://ti.com) 上的器件产品文件夹。点击 [订阅更新](#) 进行注册，即可每周接收产品信息更改摘要。有关更改的详细信息，请查看任何已修订文档中包含的修订历史记录。

### 11.4 支持资源

[TI E2E™ 支持论坛](#) 是工程师的重要参考资料，可直接从专家获得快速、经过验证的解答和设计帮助。搜索现有解答或提出自己的问题可获得所需的快速设计帮助。

链接的内容由各个贡献者“按原样”提供。这些内容并不构成 TI 技术规范，并且不一定反映 TI 的观点；请参阅 TI 的 [《使用条款》](#)。

### 11.5 Trademarks

D-CAP3™ and Eco-mode™ are trademarks of TI.

TI E2E™ is a trademark of Texas Instruments.

所有商标均为其各自所有者的财产。

### 11.6 Electrostatic Discharge Caution



This integrated circuit can be damaged by ESD. Texas Instruments recommends that all integrated circuits be handled with appropriate precautions. Failure to observe proper handling and installation procedures can cause damage.

ESD damage can range from subtle performance degradation to complete device failure. Precision integrated circuits may be more susceptible to damage because very small parametric changes could cause the device not to meet its published specifications.

### 11.7 术语表

[TI 术语表](#) 本术语表列出并解释了术语、首字母缩略词和定义。

## **12 Mechanical, Packaging, and Orderable Information**

The following pages include mechanical, packaging, and orderable information. This information is the most current data available for the designated devices. This data is subject to change without notice and revision of this document. For browser-based versions of this data sheet, refer to the left-hand navigation.

**PACKAGING INFORMATION**

Orderable Device	Status (1)	Package Type	Package Drawing	Pins	Package Qty	Eco Plan (2)	Lead finish/ Ball material (6)	MSL Peak Temp (3)	Op Temp (°C)	Device Marking (4/5)	Samples
TPSM8A28RDGR	ACTIVE	B3QFN	RDG	25	1000	RoHS & Green	NIPDAU	Level-3-250C-168 HR	-40 to 125	TPSM8A28	<a href="#">Samples</a>
TPSM8A29RDGR	ACTIVE	B3QFN	RDG	25	1000	RoHS & Green	NIPDAU	Level-3-250C-168 HR	-40 to 125	TPSM8A29	<a href="#">Samples</a>

(1) The marketing status values are defined as follows:

**ACTIVE:** Product device recommended for new designs.

**LIFEBUY:** TI has announced that the device will be discontinued, and a lifetime-buy period is in effect.

**NRND:** Not recommended for new designs. Device is in production to support existing customers, but TI does not recommend using this part in a new design.

**PREVIEW:** Device has been announced but is not in production. Samples may or may not be available.

**OBSOLETE:** TI has discontinued the production of the device.

(2) **RoHS:** TI defines "RoHS" to mean semiconductor products that are compliant with the current EU RoHS requirements for all 10 RoHS substances, including the requirement that RoHS substance do not exceed 0.1% by weight in homogeneous materials. Where designed to be soldered at high temperatures, "RoHS" products are suitable for use in specified lead-free processes. TI may reference these types of products as "Pb-Free".

**RoHS Exempt:** TI defines "RoHS Exempt" to mean products that contain lead but are compliant with EU RoHS pursuant to a specific EU RoHS exemption.

**Green:** TI defines "Green" to mean the content of Chlorine (Cl) and Bromine (Br) based flame retardants meet JS709B low halogen requirements of <=1000ppm threshold. Antimony trioxide based flame retardants must also meet the <=1000ppm threshold requirement.

(3) MSL, Peak Temp. - The Moisture Sensitivity Level rating according to the JEDEC industry standard classifications, and peak solder temperature.

(4) There may be additional marking, which relates to the logo, the lot trace code information, or the environmental category on the device.

(5) Multiple Device Markings will be inside parentheses. Only one Device Marking contained in parentheses and separated by a "~" will appear on a device. If a line is indented then it is a continuation of the previous line and the two combined represent the entire Device Marking for that device.

(6) Lead finish/Ball material - Orderable Devices may have multiple material finish options. Finish options are separated by a vertical ruled line. Lead finish/Ball material values may wrap to two lines if the finish value exceeds the maximum column width.

**Important Information and Disclaimer:**The information provided on this page represents TI's knowledge and belief as of the date that it is provided. TI bases its knowledge and belief on information provided by third parties, and makes no representation or warranty as to the accuracy of such information. Efforts are underway to better integrate information from third parties. TI has taken and continues to take reasonable steps to provide representative and accurate information but may not have conducted destructive testing or chemical analysis on incoming materials and chemicals. TI and TI suppliers consider certain information to be proprietary, and thus CAS numbers and other limited information may not be available for release.

In no event shall TI's liability arising out of such information exceed the total purchase price of the TI part(s) at issue in this document sold by TI to Customer on an annual basis.





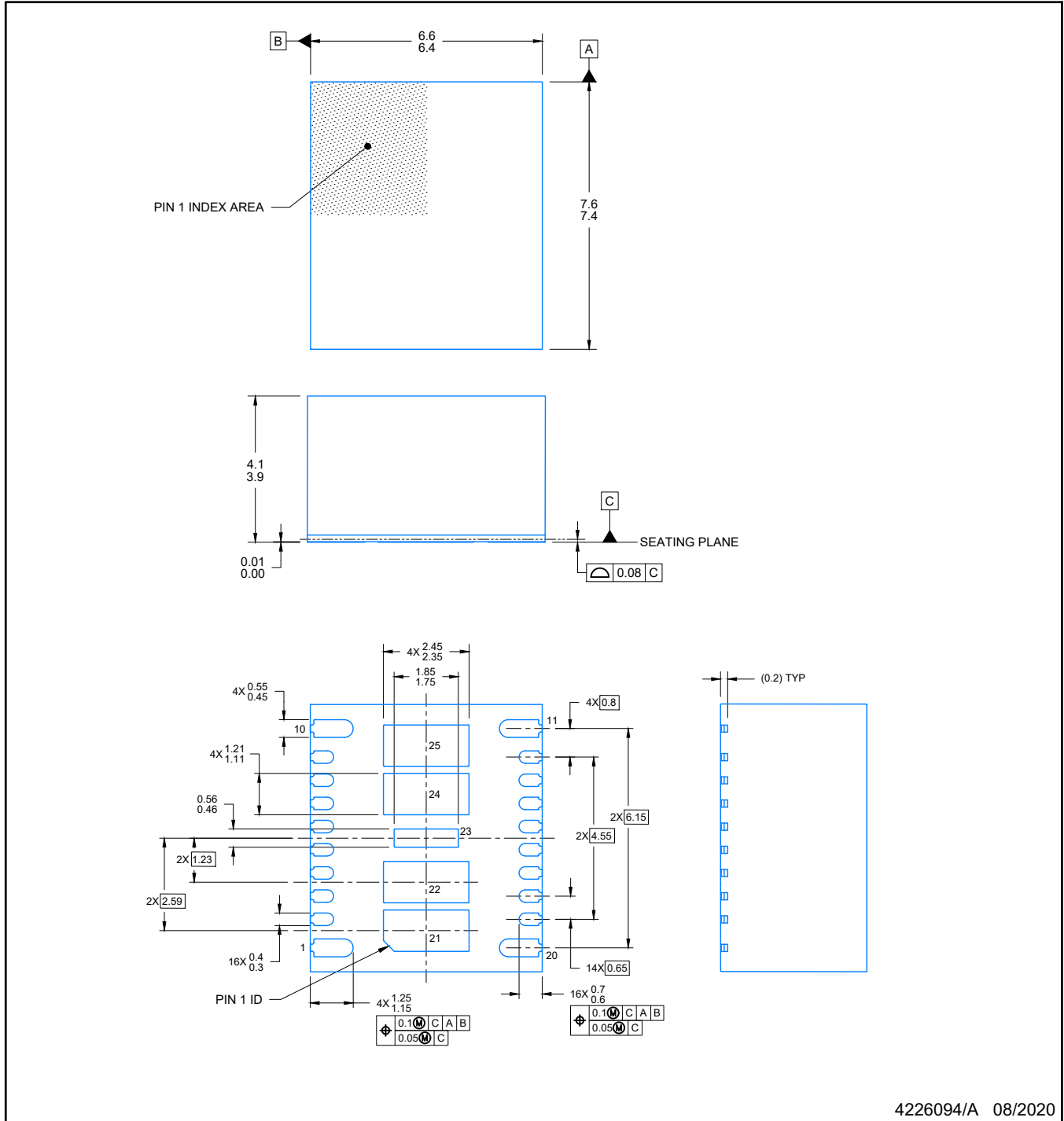

4226094/A 08/2020

NOTES:

1. All linear dimensions are in millimeters. Any dimensions in parenthesis are for reference only. Dimensioning and tolerancing per ASME Y14.5M.
2. This drawing is subject to change without notice.
3. The package thermal pad must be soldered to the printed circuit board for optimal thermal and mechanical performance.

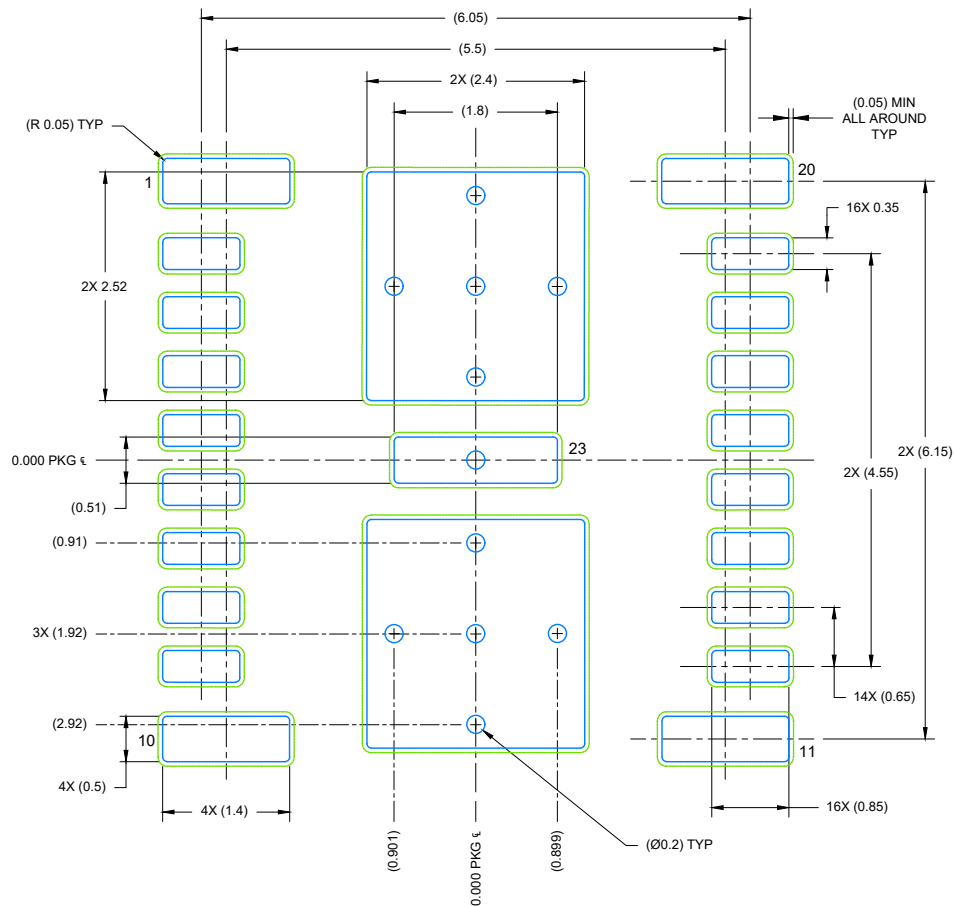

LAND PATTERN EXAMPLE  
EXPOSED METAL SHOWN  
SCALE: 12X

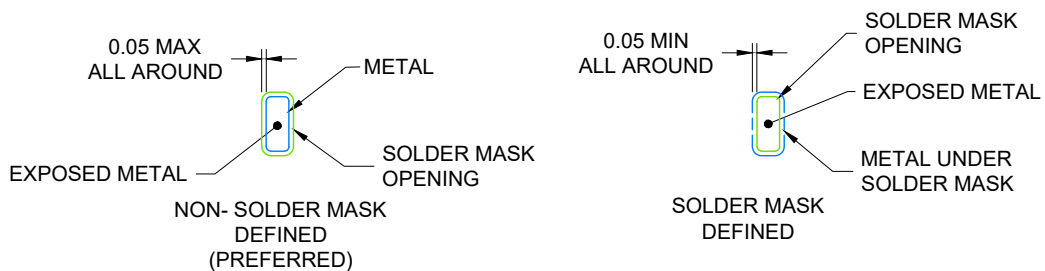

SOLDER MASK DETAILS

4226094/A 08/2020

NOTES: (continued)

4. This package is designed to be soldered to a thermal pad on the board. For more information, see Texas Instruments literature number SLUA271 ([www.ti.com/lit/slua271](http://www.ti.com/lit/slua271)).
5. Vias are optional depending on application, refer to device data sheet. If any vias are implemented, refer to their locations shown on this view. It is recommended that vias under paste be filled, plugged or tented.

# EXAMPLE STENCIL DESIGN

RDG0025A

B3QFN - 4.1 mm max height

PLASTIC QUAD FLAT PACK- NO LEAD

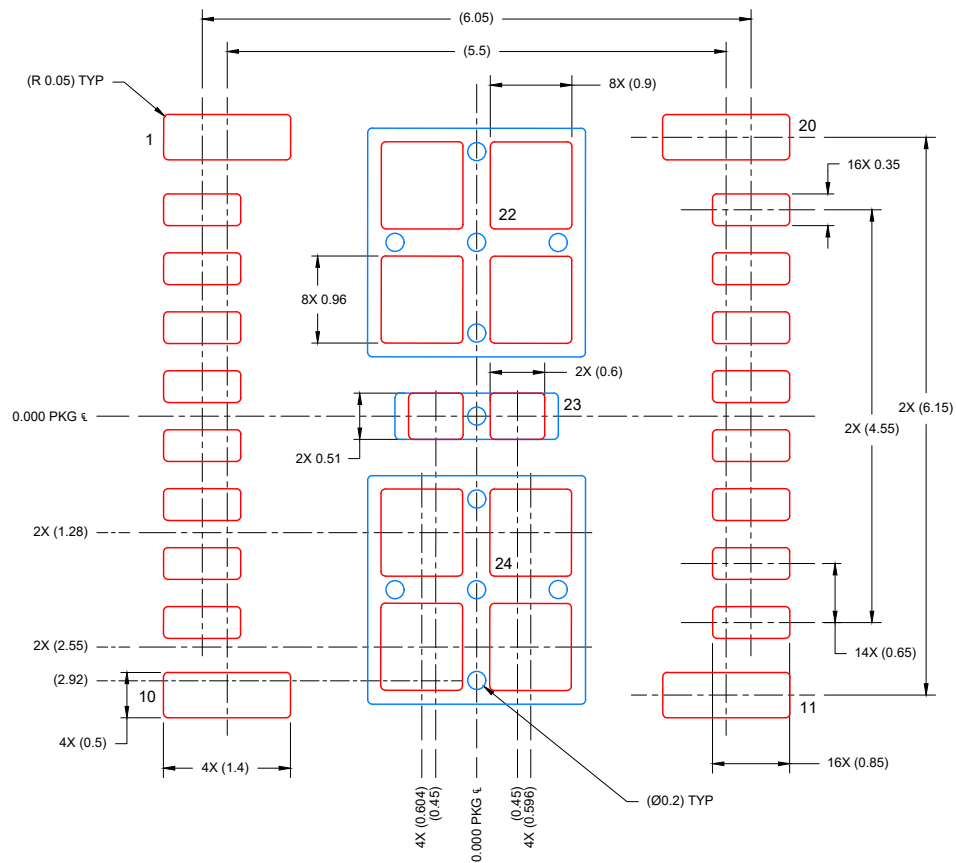

**SOLDER PASTE EXAMPLE**  
BASED ON 0.1 mm THICK STENCIL

**SOLDER COVERAGE:**

PIN 21 & 22 : 57%  
PIN 23 : 67%  
PIN 24 & 25 : 57%

SCALE: 15X

4226094/A 08/2020

NOTES: (continued)

6. Laser cutting apertures with trapezoidal walls and rounded corners may offer better paste release. IPC-7525 may have alternate design recommendations.

## 重要声明和免责声明

TI“按原样”提供技术和可靠性数据（包括数据表）、设计资源（包括参考设计）、应用或其他设计建议、网络工具、安全信息和其他资源，不保证没有瑕疵且不做任何明示或暗示的担保，包括但不限于对适销性、某特定用途方面的适用性或不侵犯任何第三方知识产权的暗示担保。

这些资源可供使用 TI 产品进行设计的熟练开发人员使用。您将自行承担以下全部责任：(1) 针对您的应用选择合适的 TI 产品，(2) 设计、验证并测试您的应用，(3) 确保您的应用满足相应标准以及任何其他功能安全、信息安全、监管或其他要求。

这些资源如有变更，恕不另行通知。TI 授权您仅可将这些资源用于研发本资源所述的 TI 产品的应用。严禁对这些资源进行其他复制或展示。您无权使用任何其他 TI 知识产权或任何第三方知识产权。您应全额赔偿因在这些资源的使用中对 TI 及其代表造成的任何索赔、损害、成本、损失和债务，TI 对此概不负责。

TI 提供的产品受 [TI 的销售条款](#) 或 [ti.com](#) 上其他适用条款/TI 产品随附的其他适用条款的约束。TI 提供这些资源并不会扩展或以其他方式更改 TI 针对 TI 产品发布的适用的担保或担保免责声明。

TI 反对并拒绝您可能提出的任何其他或不同的条款。

邮寄地址：Texas Instruments, Post Office Box 655303, Dallas, Texas 75265

Copyright © 2022，德州仪器 (TI) 公司

## X-ON Electronics

Largest Supplier of Electrical and Electronic Components

*Click to view similar products for [Switching Voltage Regulators](#) category:*

*Click to view products by [Texas Instruments](#) manufacturer:*

Other Similar products are found below :

[FAN53610AUC33X](#) [FAN53611AUC123X](#) [EN6310QA](#) [160215](#) [R3](#) [KE177614](#) [FAN53611AUC12X](#) [MAX809TTR](#) [NCV891234MW50R2G](#)  
[AST1S31PUR](#) [NCP81203PMNTXG](#) [NCP81208MNTXG](#) [PCA9412AUKZ](#) [NCP81109GMNTXG](#) [NCP3235MNTXG](#) [NCP81109JMNTXG](#)  
[NCP81241MNTXG](#) [NTE7223](#) [NTE7222](#) [NTE7224](#) [L6986FTR](#) [MPQ4481GU-AEC1-P](#) [MP8756GD-P](#) [MPQ2171GJ-P](#) [MPQ2171GJ-AEC1-P](#)  
[N JW4153U2-A-TE2](#) [MP2171GJ-P](#) [MP28160GC-Z](#) [XDPE132G5CG000XUMA1](#) [LM60440AQRPKRQ1](#) [MP5461GC-P](#) [IW673-20](#)  
[NCV896530MWATXG](#) [MPQ4409GQBE-AEC1-P](#) [S-19903DA-A8T1U7](#) [S-19903CA-A6T8U7](#) [S-19903CA-S8T1U7](#) [S-19902BA-A6T8U7](#)  
[S-19902CA-A6T8U7](#) [S-19902AA-A6T8U7](#) [S-19903AA-A6T8U7](#) [S-19902AA-S8T1U7](#) [S-19902BA-A8T1U7](#) [AU8310](#)  
[LMR23615QDRRRQ1](#) [LMR33630APAQRN XRQ1](#) [LMR33630APCQRN XRQ1](#) [LMR36503R5RPER](#) [LMR36503RFRPER](#)  
[LMR36503RS3QRPERQ1](#)