

Features

- Floating high-side driver in bootstrap operation to 600V
- Drives two N-channel MOSFETs or IGBTs in high-side/low-side configuration
- Outputs tolerant to negative transients
- Wide low-side gate driver and logic supply: 10V to 20V
- Logic inputs CMOS and TTL compatible (down to 3.3V)
- Schmitt triggered logic inputs with internal pull down
- Undervoltage lockout for V_{CC}
- Space-saving SOIC-8 package available
- Extended temperature range: -40°C to +125°C

Applications

- DC-DC Converters
- AC-DC Inverters
- Motor Controls
- Class D Power Amplifiers

Typical Application

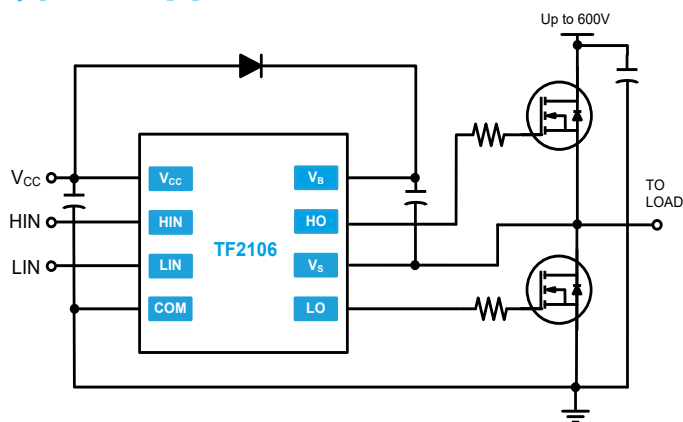

Description

The TF2106 is a high voltage, high speed gate driver capable of driving N-channel MOSFETs and IGBTs in a high-side/low-side configuration. TF Semiconductor's high voltage process enables the TF2106's high-side to switch to 600V in a bootstrap operation. The 50ns (max) propagation delay matching between the high and the low side drivers allows high frequency switching.

The TF2106 logic inputs are compatible with standard TTL and CMOS levels (down to 3.3V) for easy interfacing with controlling devices. The driver outputs feature high pulse current buffers designed for minimum driver cross conduction. The low-side gate driver and logic share a common ground

The TF2106 is available in a space-saving 8-pin SOIC package and a 8-pin PDIP; the operating temperature extends from -40°C to +125°C.





SOIC-8(N)



PDIP-8

Ordering Information

Year Year Week Week

PART NUMBER	PACKAGE	PACK / Qty	MARK
TF2106-TAU	SOIC-8(N)	Tube / 100	 YYWW TF2106 Lot ID
TF2106-TAH	SOIC-8(N)	T & R / 2500	 YYWW TF2106 Lot ID
TF2106-3AS	PDIP-8	Tube / 50	 YYWW TF2106 Lot ID

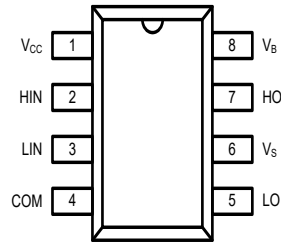

Top View: PDIP-8, SOIC-8

TF2106

Pin Descriptions

PIN NAME	PIN DESCRIPTION
HIN	Logic input for high-side gate driver output (HO), in phase
LIN	Logic input for low-side gate driver output (LO), in phase
V _B	High-side floating supply
HO	High-side gate drive output
V _S	High-side floating supply return
V _{CC}	Low-side and logic fixed supply
LO	Low-side gate drive output
COM	Low-side return
NC	"No connect" pin

Functional Block Diagram

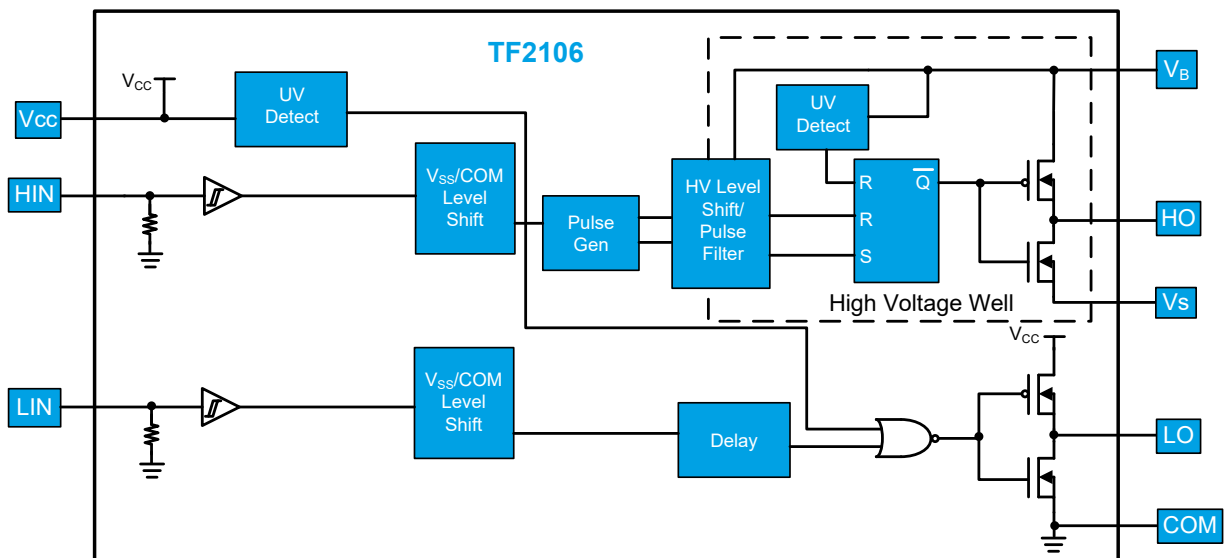

Absolute Maximum Ratings *(NOTE1)*

V_B - High side floating supply voltage.....-0.3V to +624V
 V_S - High side floating supply offset voltage... V_B -24V to V_B +0.3V
 V_{HO} - High side floating output voltage..... V_S -0.3V to V_B +0.3V
 dV_S / dt - Offset supply voltage transient.....50 V/ns

V_{CC} - Low side and logic fixed supply voltage.....-0.3V to +24V
 V_{LO} - Low side output voltage.....-0.3V to V_{CC} +0.3V
 V_{IN} - Logic input voltage (HIN and LIN)... -0.3V to V_{CC} +0.3V

NOTE1 Stresses beyond those listed under "Absolute Maximum Ratings" may cause permanent damage to the device. These are stress ratings only, and functional operation of the device at these or any other conditions beyond those indicated in the operational sections of the specifications is not implied. Exposure to absolute maximum rating conditions for extended periods may affect device reliability.

P_D - Package power dissipation at $T_A \leq 25^\circ\text{C}$
 SOIC-8.....0.625W
 PDIP-8.....1.0W

SOIC-8 Thermal Resistance (NOTE2)
 θ_{JC}45 $^\circ\text{C}/\text{W}$
 θ_{JA}200 $^\circ\text{C}/\text{W}$

PDIP-8 Thermal Resistance (NOTE2)
 θ_{JC}35 $^\circ\text{C}/\text{W}$
 θ_{JA}125 $^\circ\text{C}/\text{W}$

T_J - Junction operating temperature+150 $^\circ\text{C}$
 T_L - Lead temperature (soldering, 10s) +300 $^\circ\text{C}$
 T_{stg} - Storage temperature range-55 $^\circ\text{C}$ to +150 $^\circ\text{C}$

NOTE2 When mounted on a standard JEDEC 2-layer FR-4 board.

Recommended Operating Conditions

Symbol	Parameter	MIN	TYP	MAX	Unit
V_B	High side floating supply absolute voltage	$V_S + 10$		$V_S + 20$	V
V_S	High side floating supply offset voltage	NOTE3		600	V
V_{HO}	High side floating output voltage	V_S		V_B	V
V_{CC}	Low side and logic fixed supply voltage	10		20	V
V_{LO}	Low side output voltage	0		V_{CC}	V
V_{IN}	Logic input voltage (HIN and LIN)	0		5	V
T_A	Ambient temperature	-40		125	$^\circ\text{C}$

NOTE3 Logic operational for $V_S = -5$ to +600V.

DC Electrical Characteristics (NOTE4)

$V_{BIAS} (V_{CC}, V_{BS}) = 15V, T_A = 25^\circ C$, unless otherwise specified.

Symbol	Parameter	Conditions	MIN	TYP	MAX	Unit
V_{IH}	Logic "1" input voltage	$V_{CC} = 10V$ to $20V$	2.5			V
V_{IL}	Logic "0" input voltage	$V_{CC} = 10V$ to $20V$			0.6	V
V_{OH}	High level output voltage, $V_{BIAS} - V_O$	$I_O = 2mA$		0.05	0.2	V
V_{OL}	Low level output voltage, V_O	$I_O = 2mA$		0.02	0.1	V
I_{LK}	Offset supply leakage current	$V_B = V_S = 600V$			50	μA
I_{BSQ}	Quiescent V_{BS} supply current	$V_{IN} = 0V$ or $5V$	20	75	130	μA
I_{CCQ}	Quiescent V_{CC} supply current	$V_{IN} = 0V$ or $5V$	60	120	180	μA
I_{IN+}	Logic "1" input bias current	$V_{IN} = 5V$		5	20	μA
I_{IN-}	Logic "0" input bias current	$V_{IN} = 0V$			2	μA
V_{CCUV+}	V_{CC} supply under-voltage positive going threshold		8	8.9	9.8	V
V_{CCUV-}	V_{CC} supply under-voltage negative going threshold		7.4	8.2	9	V
V_{BSUV+}	V_{BS} supply under-voltage positive going threshold		8	8.9	9.8	V
V_{BSUV-}	V_{BS} supply under-voltage negative going threshold		7.4	8.2	9	V
V_{UVLOH}	Undervoltage lockout hysteresis		0.3	0.7		V
I_{O+}	Output high short circuit pulsed current	$V_O = 0V, V_{IN} = \text{Logic "1"}, PW \leq 10 \mu s$	130	290		mA
I_{O-}	Output low short circuit pulsed current	$V_O = 15V, V_{IN} = \text{Logic "0"}, PW \leq 10 \mu s$	270	600		mA

AC Electrical Characteristics

$V_{BIAS} (V_{CC}, V_{BS}) = 15V, T_A = 25^\circ C$, and $C_L = 1000pF$, unless otherwise specified.

Symbol	Parameter	Conditions	MIN	TYP	MAX	Unit
t_{ON}	Turn-on propagation delay	$V_S = 0V$		220	300	ns
t_{OFF}	Turn-off propagation delay	$V_S = 0V$ or $600V$		200	280	ns
t_r	Turn-on rise time			100	220	ns
t_f	Turn-off fall time	$V_S = 0V$		35	80	ns
t_{DM}	Delay matching				30	ns

NOTE4 The V_{IH} , V_{IL} , and I_{IN} parameters are referenced to COM. The V_O and I_O parameters are referenced to COM and are applicable to the respective output pins: HO and LO.

Timing Waveforms

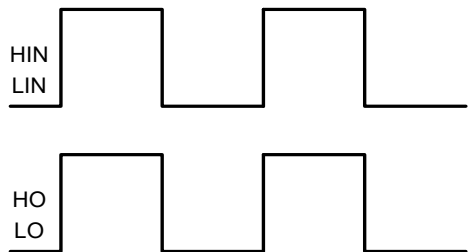

Figure 1. Input / Output Timing Diagram

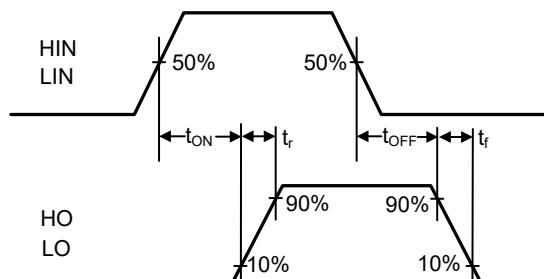

Figure 2. Switching Time Waveform Definitions

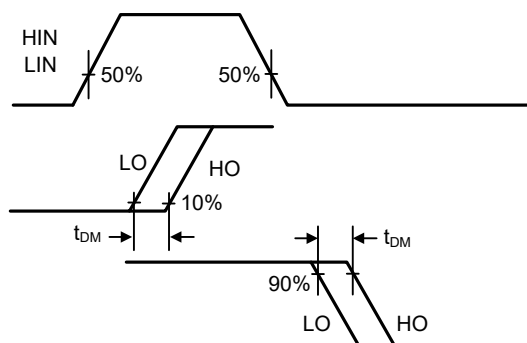

Figure 3. Delay Matching Waveform Definitions

Typical Characteristics

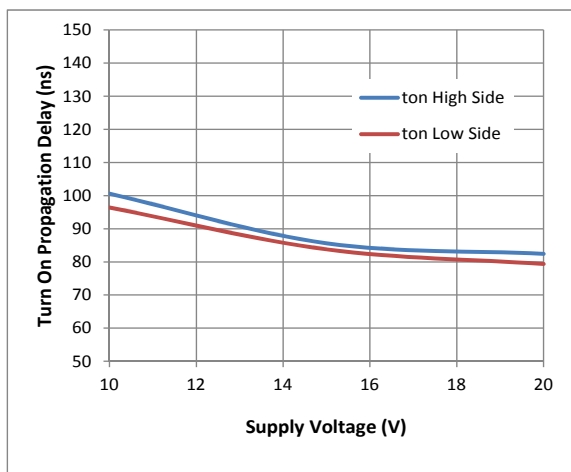

Figure 4. Turn-on Propagation Delay vs. Supply Voltage

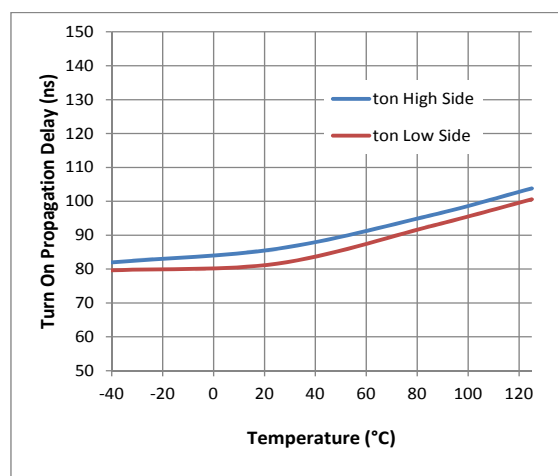

Figure 5. Turn-on Propagation Delay vs. Temperature

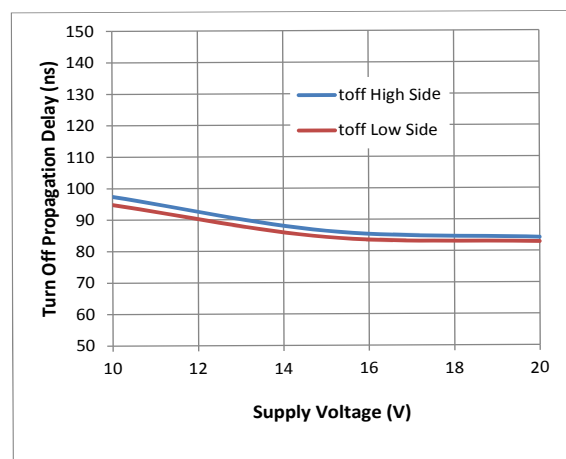

Figure 6. Turn-off Propagation Delay vs. Supply Voltage

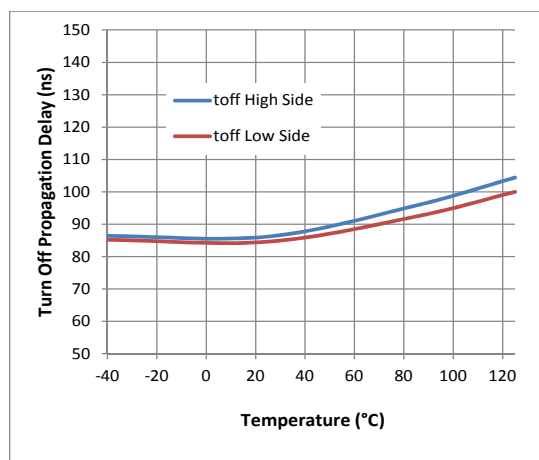

Figure 7. Turn-off Propagation Delay vs. Temperature

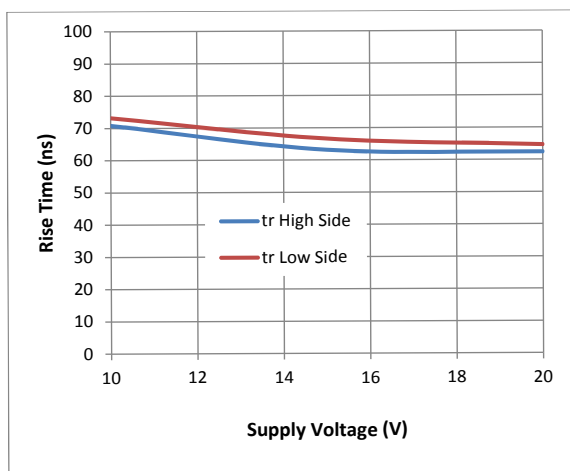

Figure 8. Rise Time vs. Supply Voltage

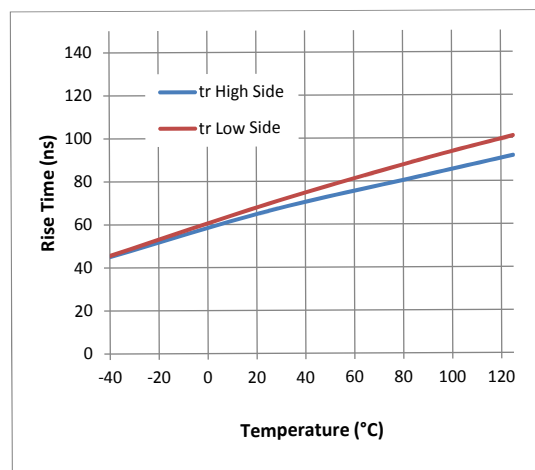

Figure 9. Rise Time vs. Temperature

Typical Characteristics, cont'd

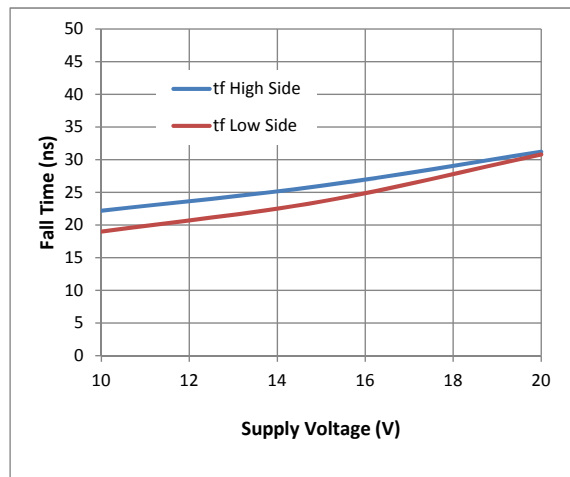

Figure 10. Fall Time vs. Supply Voltage

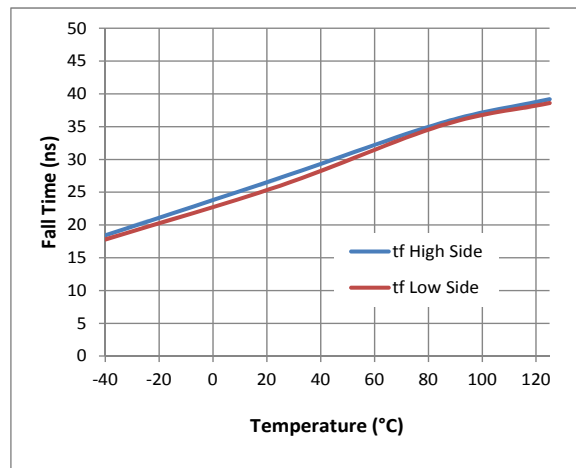

Figure 11. Fall Time vs. Temperature

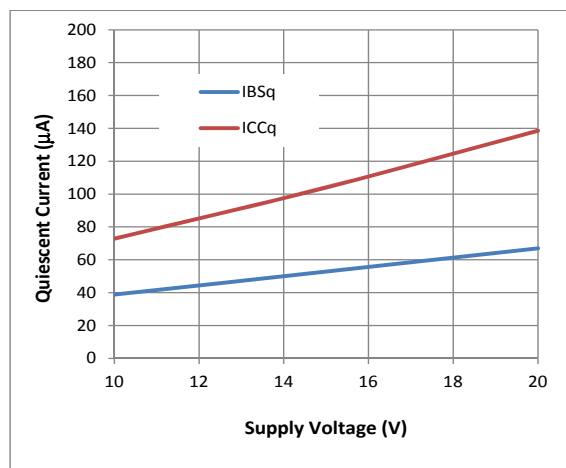

Figure 12. Quiescent Current vs. Supply Voltage

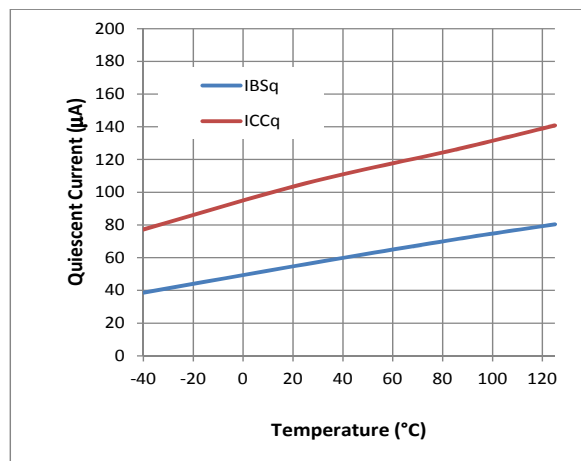

Figure 13. Quiescent Current vs. Temperature

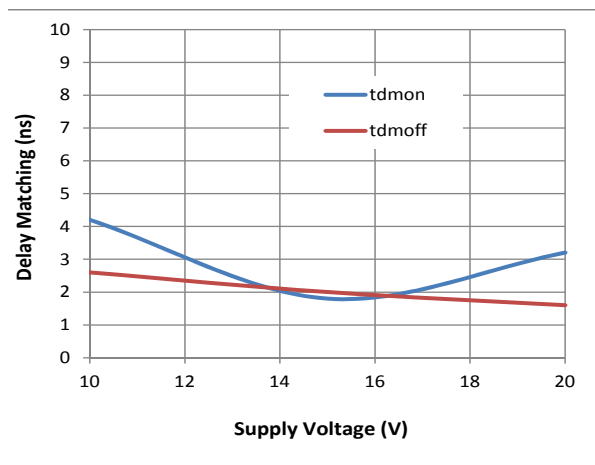

Figure 14. Delay Matching vs. Supply Voltage

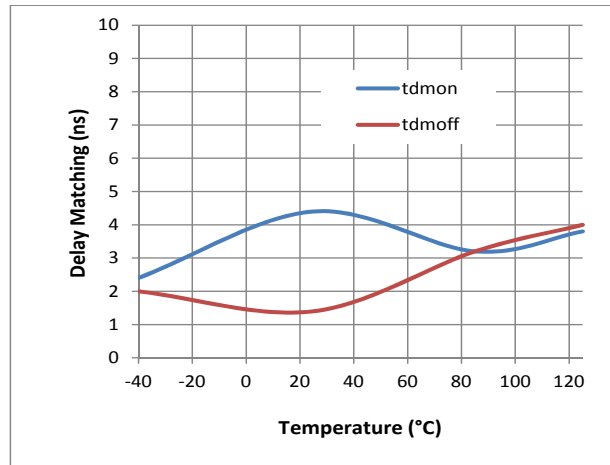

Figure 15. Delay Matching vs. Temperature

Typical Characteristics, cont'd

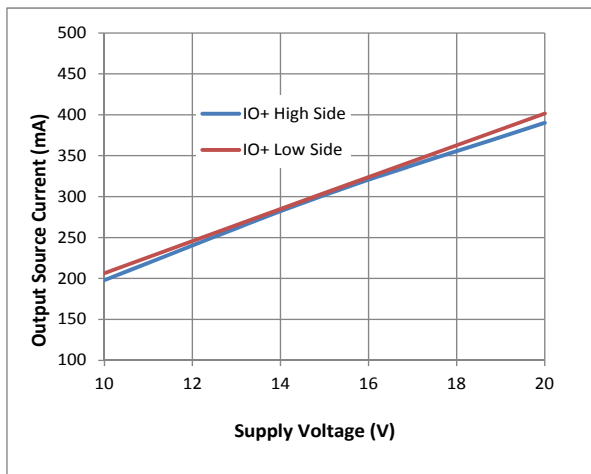

Figure 16. Output Source Current vs. Supply Voltage

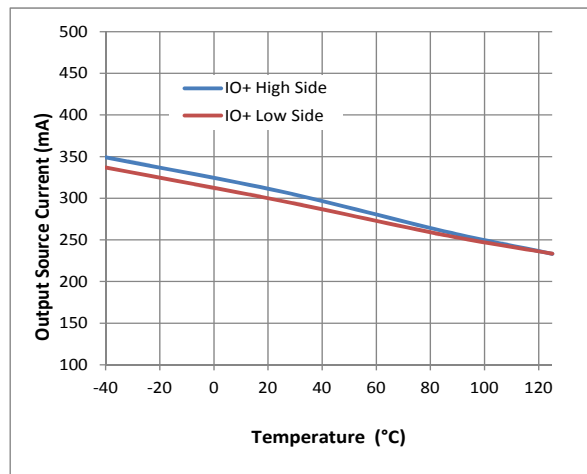

Figure 17. Output Source Current vs. Temperature

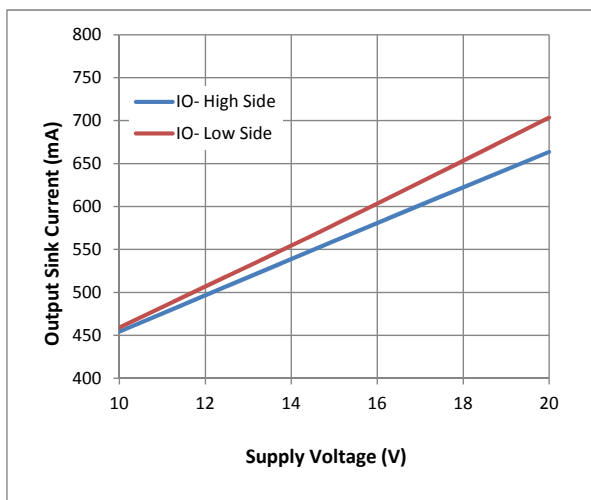

Figure 18. Output Sink Current vs. Supply Voltage

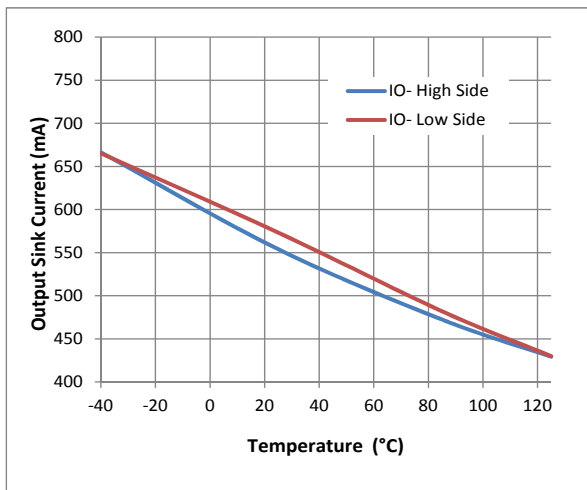

Figure 19. Output Sink Current vs. Temperature

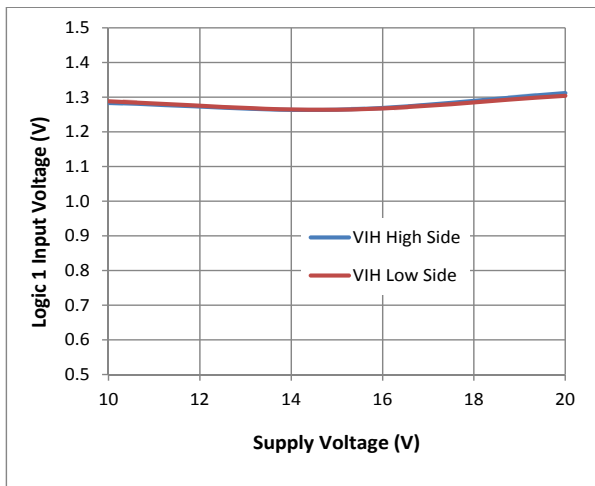

Figure 20. Logic 1 Input Voltage vs. Supply Voltage

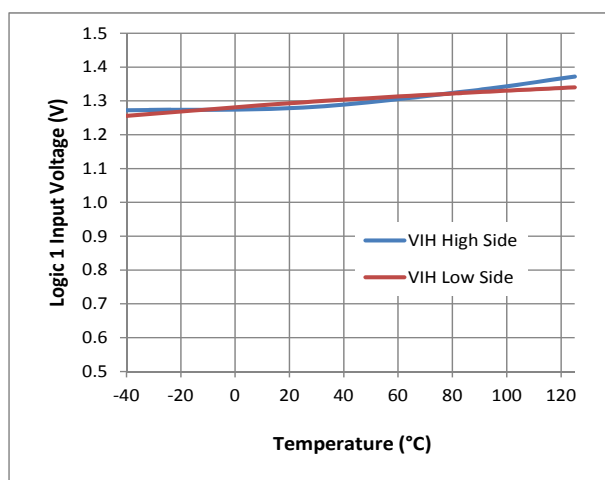

Figure 21. Logic 1 Input Voltage vs. Temperature

Typical Characteristics, cont'd

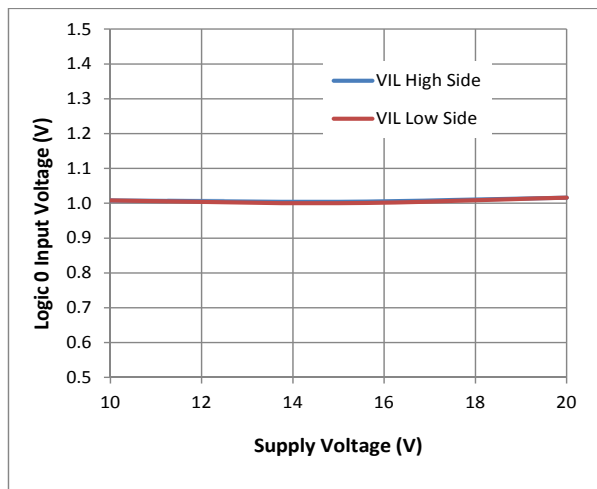

Figure 22. Logic 0 Input Voltage vs. Supply Voltage

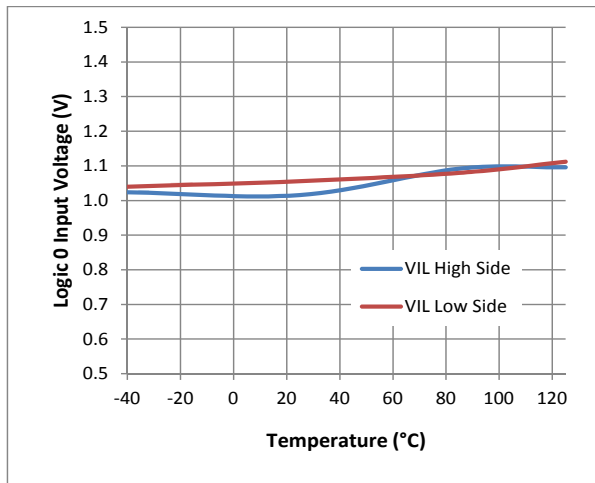

Figure 23. Logic 0 Input Voltage vs. Temperature

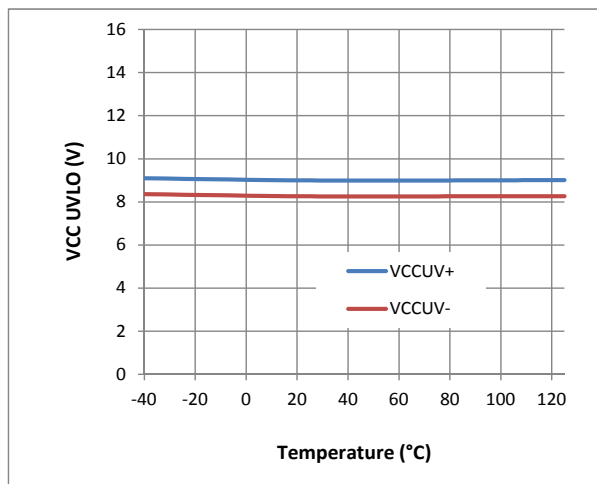

Figure 24. V_{CC} UVLO vs. Temperature

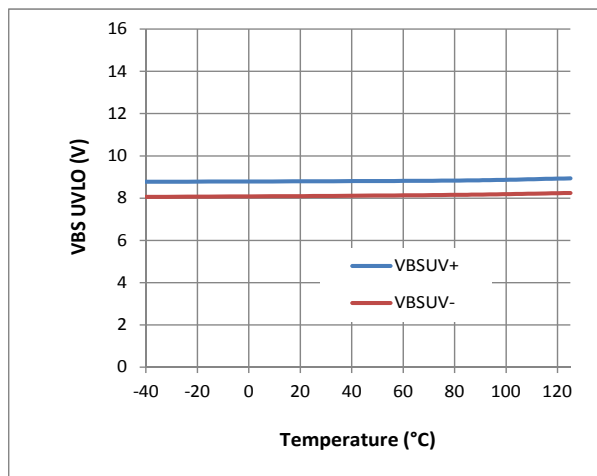

Figure 25. V_{BS} UVLO vs. Temperature

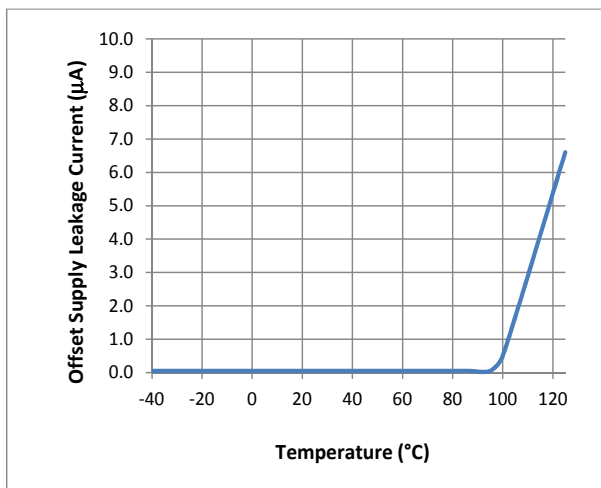

Figure 26. Offset Supply Leakage Current Temperature

Operation

Halfbridge Configuration

A common configuration used for the TF2106 is a half-bridge (see fig. 28). In a half-bridge configuration the source of the high-side MOSFET (Q_H) and the drain of the low-side MOSFET (Q_L) are connected. That line (V_S) is both the return for the high side in the gate driver IC as well as the output of the half-bridge. When Q_H is on and Q_L is off, V_S swings to high voltage, and when Q_H is off and Q_L is on, V_S swings to GND. Hence the output switches from GND to high voltage at the frequency of HIN and LIN, this line drives a transformer for a power supply, or a coil on a motor.

In this half-bridge configuration, high voltage DC is input to the MOSFETs, and converted to a high voltage switching signal to output to load (fig 28). The MOSFETs operate in saturation mode and an important function of the gate driver is to turn on the MOSFET quickly to minimize switching losses from the linear region of the MOSFET (turn on and turn off); the TF2106 has a typical rise/fall time of 100ns/35ns into a 1nF load.

Another important function of the gate driver IC in the half-bridge configuration is to convert the logic signals of control (TF2106 operates at logic 3.3V), to a voltage level and current capacity to drive the gate of the MOSFET and IGBT; this requires driving large currents initially to turn on/turn off the MOSFET quickly. Also the floating well of the high-side allows high voltage operation in the bootstrap operation.

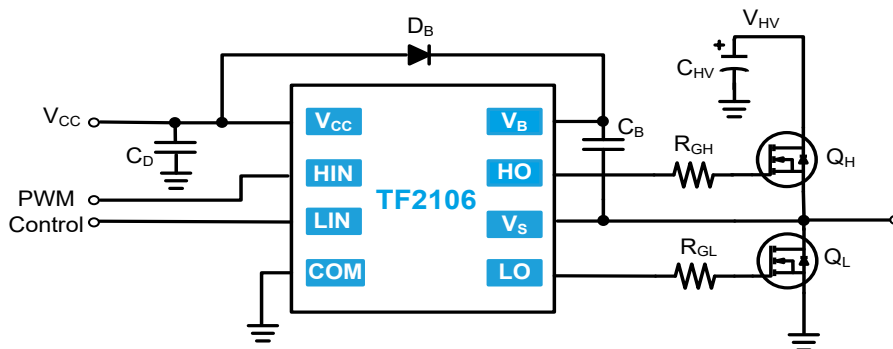

Figure 28. TF2106 in a half-bridge configuration

Bootstrap Operation

The supply for the TF2106 High Side is provided by the bootstrap capacitor C_B (see fig 29). In the half-bridge configuration, V_S swings from 0V to V_{HV} depending on the PWM input of the IC. When V_S is 0V, V_{BS} will go below V_{CC} and V_{CC} will charge C_B . When HO goes high, V_S swings to V_{HV} , and V_{BS} remains at V_{CC} minus a diode drop (D_B) due to the voltage on C_B . This is the supply for the high side gate driver and allows the gate driver to function with the floating well (V_S) at the high voltage.

When considering the **value of the bootstrap capacitor C_B** , it is important that it is sized to provide enough energy to quickly drive the gate of Q_H . Values of 1 μ F to 10 μ F are recommended, exact value depending on gate capacitance, and the noise in application. It is key to use a low ESR capacitor that is close to the device. This will best quickly supply charge to the gate of the MOSFET.

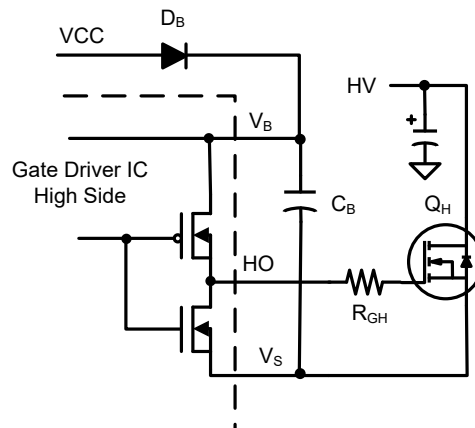

Figure 29. TF2106 high side in bootstrap operation

For a more detailed description on Gate Resistor Selection and Bootstrap Capacitor Selection, see the TF Semiconductor’s Gate Driver Application Note (AN1347).

Gate Drive Control

The most crucial time in the gate drive is the turn on and turn off of the MOSFET, and performing this function quickly, but with minimal noise and ringing is key. Too fast a rise/fall time can cause unnecessary ringing, and too slow a rise/fall time will increase switching losses in the MOSFET.

An example of just the high side gate driver is shown in figure 30 (any selection of gate driver components should be the same for high side and low side drive); two extra components are seen, R_{DH} and D_H . With the careful selection of R_{GH} and R_{DH} , it is possible to selectively control the rise time and fall time of the gate drive. For turn on, all current will go from the IC through R_{GH} and charge the MOSFET gate capacitor, hence increasing or decreasing R_{GH} will increase or decrease rise time in the application. With the addition of D_H , the fall time can be separately controlled as the turn off current flows from the MOSFET gate capacitor, through D_H and R_{DH} to the driver in the IC to V_S . So increasing or decreasing R_{DH} will increase or decrease the fall time.

Increasing turn on and turn off has the effect of limiting ringing and noise due to parasitic inductances, hence with a noisy environment, it may be necessary to increase the gate resistors. For **gate resistor value selection** the exact value depends on the type of application and desired level of noise and ringing expected. Generally, power supplies switch at a fast speed, and want to squeeze out efficiency of the MOSFETs, so lower values are recommended, for example $R_{GH} = 5\Omega - 20\Omega$. For motors, the switching speed is generally slower, and the application has more inherent noise, so higher values are recommended, for example $R_{GH} = 20\Omega - 100\Omega$.

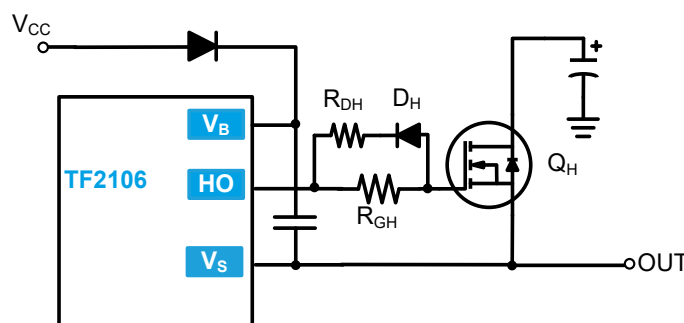

Figure 30. Gate Drive Control

Application Information

Layout Considerations

Layout plays a considerable role in noise and ringing in a circuit; unwanted noise coupling, unpredicted glitches and abnormal operation could arise due to poor layout of the associated components. Figure 31 shows a halfbridge schematic with parasitic inductances in the high current path (L_{P1} , L_{P2} , L_{P3} , L_{P4}) which would be caused by inductance in the metal of the trace. Considering fig. 31, the length of the tracks in red should be minimized, and the bootstrap capacitor (C_B) and the decoupling capacitor (C_D) should be placed as close to the IC as possible. Low ESR ceramic capacitors should be used to minimize inductance. And finally the gate resistors (R_{GH} and R_{GL}) and the sense resistor (R_S) should be surface mount devices. These suggestions will reduce the parasitics due to the PCB traces.

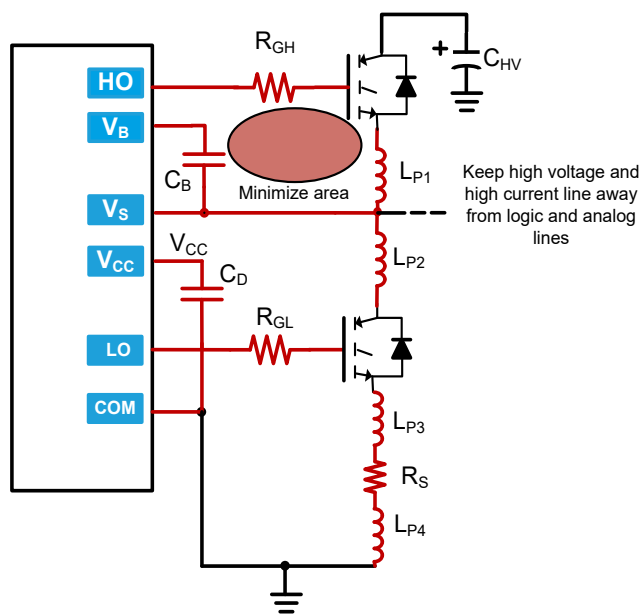

Figure 31. Layout Suggestions for TF2106 in a halfbridge

A layout example is seen in figure 32. Here there are two bootstrap capacitors (CB1 and CB2) and two decoupling capacitors (C1 and C2), and the caps are placed as close as possible to the HVIC. But even if only using one bootstrap cap and one decoupling capacitor, it needs to be as close as possible to minimize inductance between the cap and the driver.

Generally, for the **decoupling capacitor** on VCC, at least one low ESR capacitor is recommended with it close to the device as shown in figure 32. Recommended values are $1\mu\text{F}$ to $10\mu\text{F}$. A second smaller decoupling capacitor is sometimes added to provide better high frequency response (for example $0.1\mu\text{F}$).

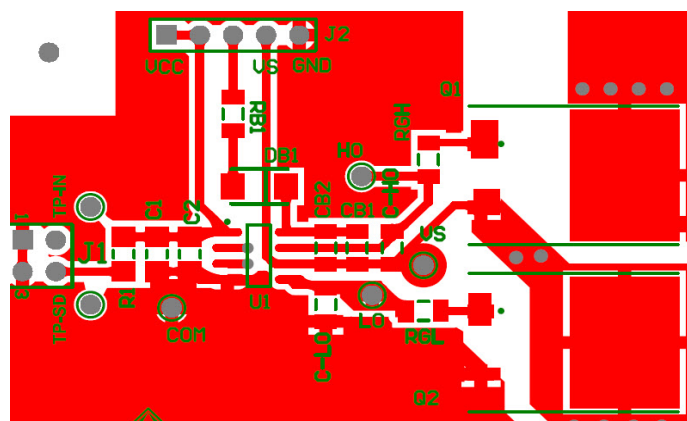
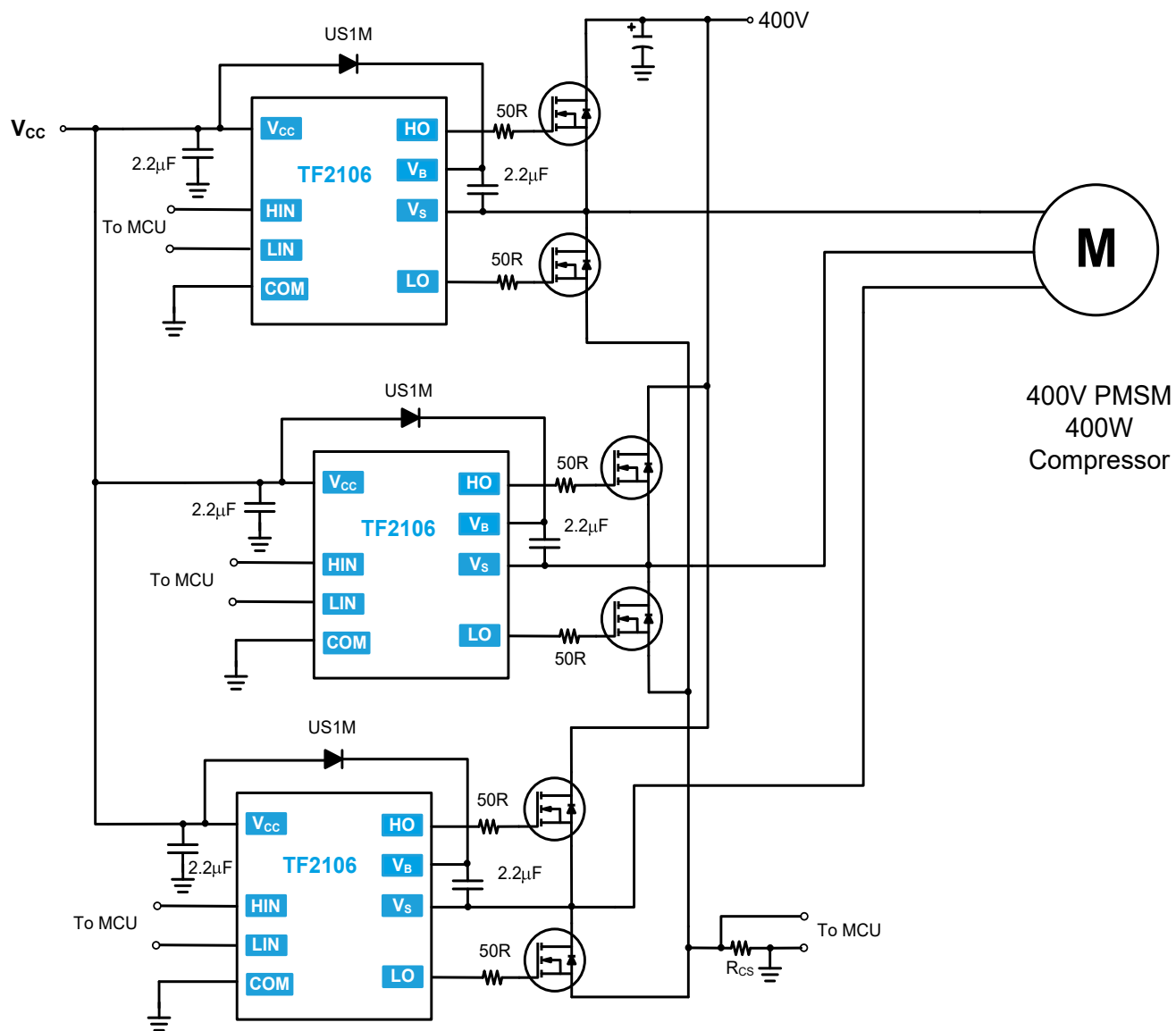

Figure 32. Layout example for TF2106 (U1) in a halfbridge, notice the bootstrap caps (CB1, CB2), VCC caps (C1 and C2), and bootstrap diode (DB1) adjacent to the IC.

Application Example



Package Dimensions (SOIC-8 N)

Please contact support@tfsemi.com for package availability.

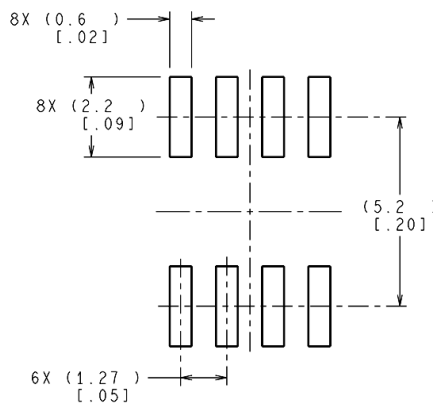
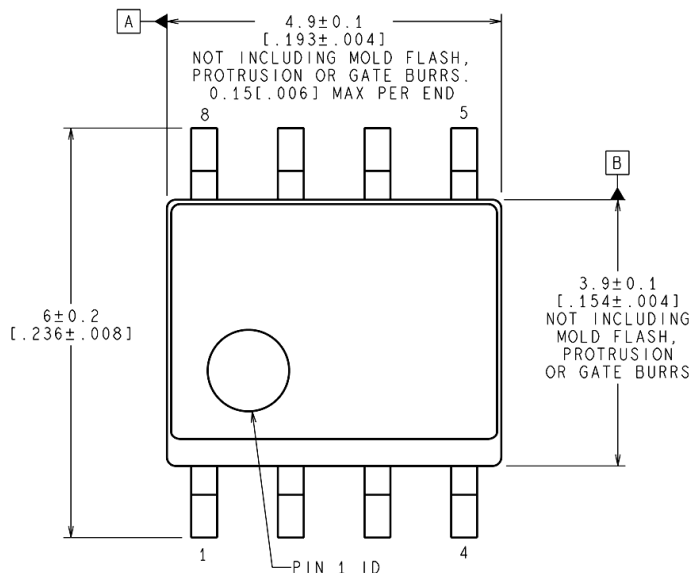

RECOMMENDED LAND PATTERN

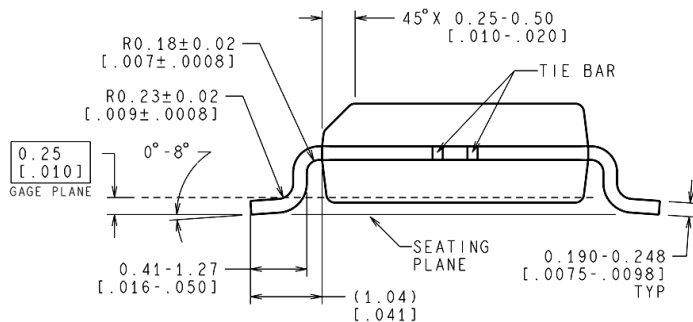
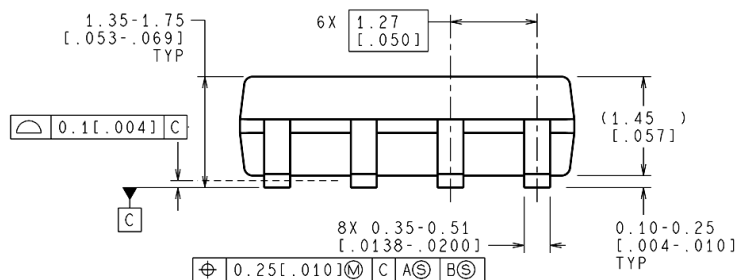

CONTROLLING DIMENSION IS MILLIMETER
VALUES IN [] ARE INCHES
DIMENSIONS IN () FOR REFERENCE ONLY

NOTES: UNLESS OTHERWISE SPECIFIED

1. REFERENCE JEDEC REGISTRATION MS-012, VARIATION AA.

Package Dimensions (PDIP-8)

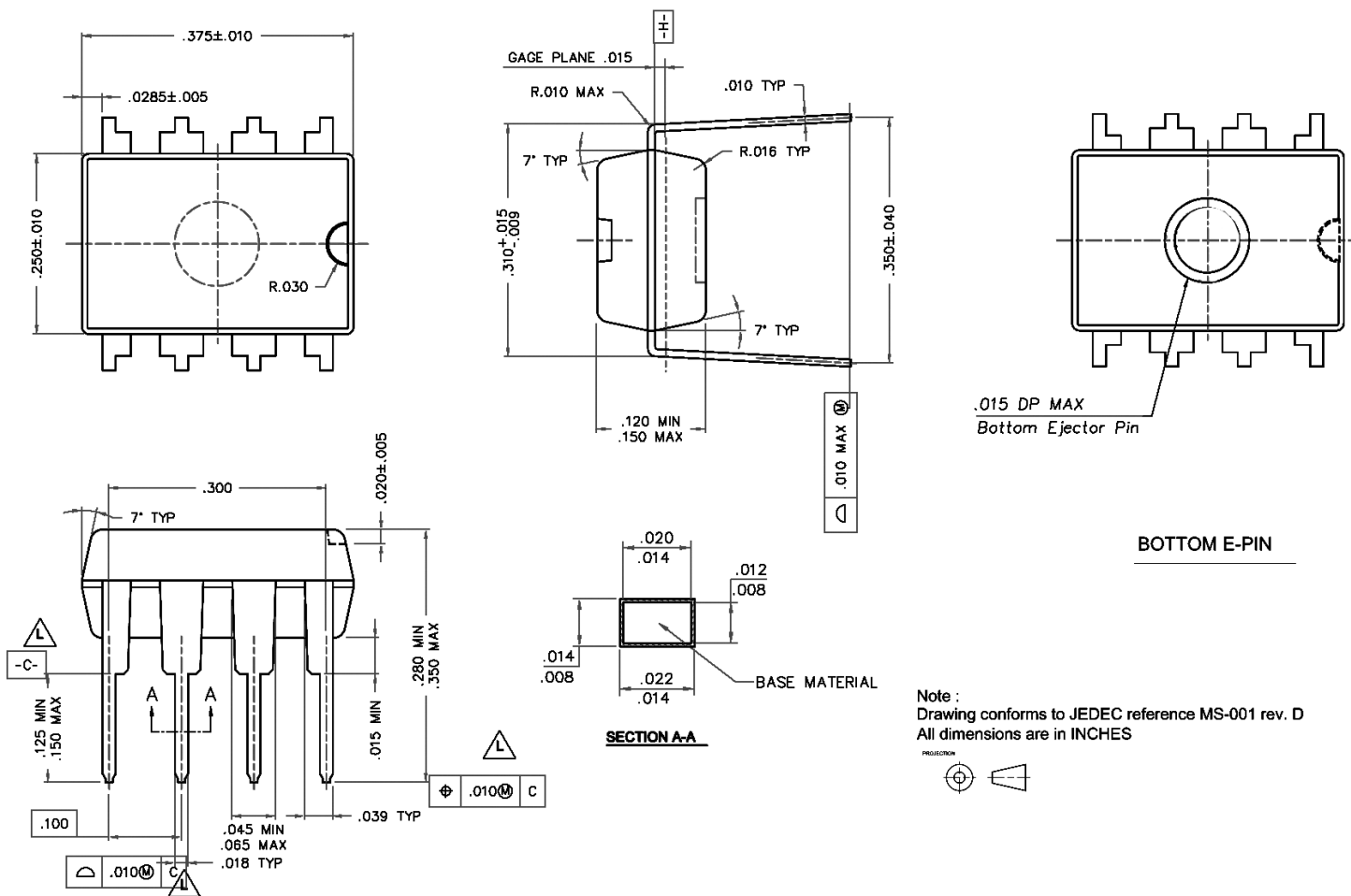

Note :
Drawing conforms to JEDEC reference MS-001 rev. D
All dimensions are in INCHES

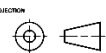

Revision History

Rev.	Change	Owner	Date
1.0	First release, final datasheet	Keith Spaulding	3/22/16
1.1	Text edit	Keith Spaulding	9/10/17

Important Notice

TF Semiconductor Solutions (TFSS) PRODUCTS ARE NEITHER DESIGNED NOR INTENDED FOR USE IN MILITARY AND/OR AEROSPACE, AUTOMOTIVE OR MEDICAL DEVICES OR SYSTEMS UNLESS THE SPECIFIC TFSS PRODUCTS ARE SPECIFICALLY DESIGNATED BY TFSS FOR SUCH USE. BUYERS ACKNOWLEDGE AND AGREE THAT ANY SUCH USE OF TFSS PRODUCTS WHICH TFSS HAS NOT DESIGNATED FOR USE IN MILITARY AND/OR AEROSPACE, AUTOMOTIVE OR MEDICAL DEVICES OR SYSTEMS IS SOLELY AT THE BUYER'S RISK.

TFSS assumes no liability for application assistance or customer product design. Customers are responsible for their products and applications using TFSS products.

Resale of TFSS products or services with statements different from or beyond the parameters stated by TFSS for that product or service voids all express and any implied warranties for the associated TFSS product or service. TFSS is not responsible or liable for any such statements.

©2016 TFSS. All Rights Reserved. Information and data in this document are owned by TFSS wholly and may not be edited, reproduced, or redistributed in any way without the express written consent from TFSS.

For additional information please contact support@tfsemi.com or visit www.tfsemi.com

X-ON Electronics

Largest Supplier of Electrical and Electronic Components

Click to view similar products for [Gate Drivers](#) category:

Click to view products by [TFSS](#) manufacturer:

Other Similar products are found below :

[00053P0231](#) [56956](#) [57.404.7355.5](#) [LT4936](#) [57.904.0755.0](#) [5882900001](#) [00600P0005](#) [5951900000](#) [0131700000](#) [00-2240](#) [LTP70N06](#)
[LVP640](#) [5J0-1000LG-SIL](#) [LY2-US-AC240](#) [LY3-UA-DC24](#) [00576P0020](#) [LZNQ2-US-DC12](#) [LZP40N10](#) [0207100000](#) [0207400000](#)
[60100564](#) [60249-1-CUT-TAPE](#) [0134220000](#) [6035](#) [60713816](#) [M15730061](#) [61161-90](#) [61278-0020](#) [6131-204-23149P](#) [6131-205-17149P](#)
[6131-209-15149P](#) [6131-218-17149P](#) [6131-220-21149P](#) [6131-260-2358P](#) [6131-265-11149P](#) [CS1HCPU63](#) [6150300002](#) [6150-5001](#) [CSK-38-](#)
[60006](#) [CSK-38-60008](#) [621A](#) [622-4053LF](#) [6273](#) [M37730026](#) [M40N08MA-H](#) [M55155/29XH06](#) [64-807](#) [65003](#) [65-1930-6](#) [M82310002](#)