

Product Specification

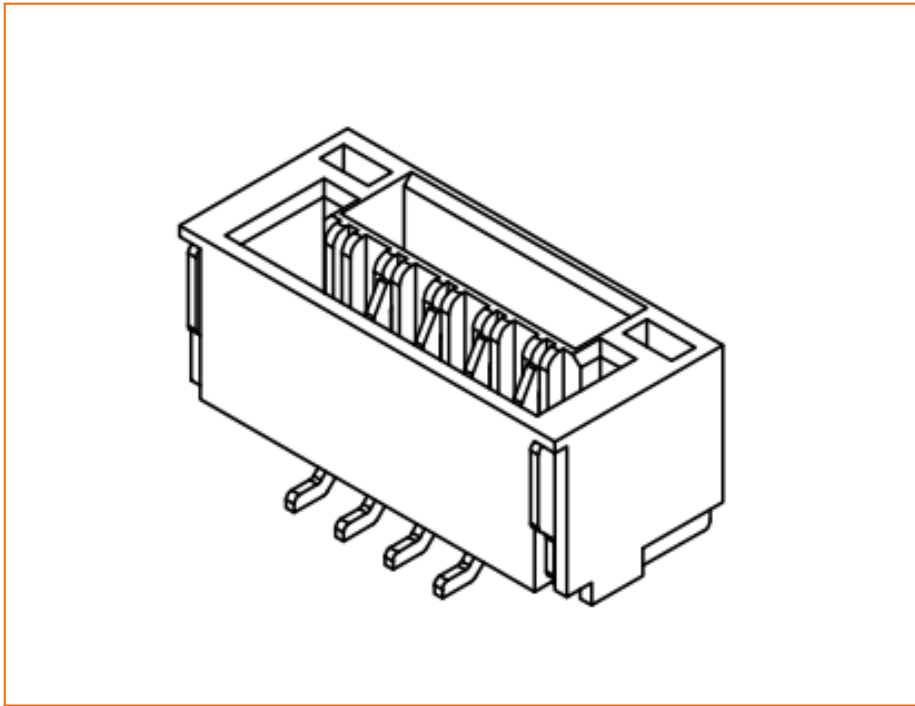

深圳市臺華達科技有限公司

SHENZHEN THD Electronics Co., Ltd.



Product.No

THD1253-xxWV-SN

Pitch=1.25mm, Wafer Connector (Front-Flip Lower Contact)

A	Release
Rev.	Description

Approved Signatures

■Prepared By : JIM	■Date: 2016.06.28
■Checked By : JIM	■Date: 2016.06.28
■Approved By : 黄德进	■Date: 2016.06.28

Scope

This specification covers the 1.25 mm Pitch wafer Connector THD1253 series.

Ordering information

THD1253 - XX - WV - SN

① ② ③ ④

①	Series name: THD1253	④	Plating : GF= 1μ"~3μ" Gold Flash G3= 3μ" Gold over Nickel G5= 5μ" Gold over Nickel SN= Tin(Lead Free) over Nickel
②	Number of contacts : 2 TO 20		
③	Contact type : WR:Right Angle SMT WV:Vertical Angle SMT		

Rating

Item	Standard
Voltage Rating (Max.)	50V AC
Current Rating (Max.)	1A DC
Operating Temperature Range	-25°C ~ +85°C (Including terminal temperature rise)

Material

Housing	Actuator	Terminal	Solder pin	Plating
LCP (UL94V-0)		Copper alloy	Copper alloy	SN= Tin(Lead Free) over Nickel
Color : Natural				

Performance

Item	Test Condition	Specification	
Contact Resistance	Mate applicable FPC and measure by dry circuit, 20mV Max, 1mA.	20 mΩ Max.	
Insulation Resistance	Mate applicable FPC and apply 500V DC between adjacent terminal or ground.	100 MΩ Min.	
Dielectric Strength	Mate applicable FPC, apply 250V AC(rms) for 1 minute between adjacent terminal or ground.	No Breakdown	
FPC Retention Force	Insert the actuator, pull the FPC at a rate of 25±3mm per minute.	Per pin x 0.6N Min.	
Terminal Retention Force	Apply axial pull out force at the rate of 25±3mm/minute on the terminal assembled in the housing.	Per pin x 0.15Kgf {6N} Min.	
Vibration	Mate connectors and subject to the following vibration conditions, for period of 2 hours in each of 3 mutually perpendicular axes, passing DC 1mA during the test. Amplitude : 1.5mm P-P Frequency : 10~55~10 Hz in 1 minute. Duration : 2 hours in each of X,Y,Z axes.	Appearance	No Damage
		Contact Resistance	100 mΩ Max.
		Discontinuity	1 μsec Max.
Shock	Mate applicable FPC and subject to the following shock conditions. 3 times of shocks shall be applied for each 6 directions along 3 mutually perpendicular axes, passing DC 1 mA current during the test. Peak value : 490m/s ² {50G}	Appearance	No Damage
		Contact Resistance	100 mΩ Max.
		Discontinuity	1 μsec Max.
Salt Spray	Mate applicable FPC and expose to the following salt mist conditions. Upon completion of the exposure period, salt deposits shall be removed by a gentle wash or dip in running water, after which the specified measurements shall be performed.	Appearance	No Damage

	NaCl solution Concentration : 5 ± 1% Spray time : 48 ± 4 hours Ambient temperature : 35 ± 2°C	Contact Resistance	100 mΩ Max.
--	--	--------------------	-------------

Item	Test Condition	Specification	
Heat Resistance	Mate applicable FPC and expose to 85±2°C for 96 hours. Upon completion of the exposure period, the test specimens shall be conditioned at ambient room conditions for 1 to 2 hours, after which the specified measurements shall be performed.	Appearance	No Damage
		Contact Resistance	100 mΩ Max.
Cold Resistance	Mate applicable FPC and expose to -40±2°C for 96 hours. Upon completion of the exposure period, the test specimens shall be conditioned at ambient room conditions for 1 to 2 hours, after which the specified measurements shall be performed.	Appearance	No Damage
		Contact Resistance	100 mΩ Max.
Humidity	Mate applicable FPC and expose to 60 ± 2°C, relative humidity 90 to 95% for 96 hours. Upon completion of the exposure period, the test specimens shall be conditioned at ambient room conditions for 1 to 2 hours, after which the specified measurements shall be performed.	Appearance	No Damage
		Contact Resistance	100 mΩ Max.
		Dielectric Strength	No Breakdown
		Insulation Resistance	50 MΩ Min.
Temperature Rise	Mate applicable FPC and measure the temperature rise of contact when the maximum AC rated current is passed.	Temperature rise	30°C Max.
Temperature Cycling	Mate applicable FPC and subject to the following conditions for 5 cycles. Upon completion of the exposure period, the test specimens shall be conditioned at ambient room conditions for 1 to 2 hours, after which the specified measurements shall be performed. 1 cycle a) -55±3°C 30minutes b) +85±3°C 30minutes (Transit time shall be with in 3 minutes)	Appearance	No Damage
		Contact Resistance	100 mΩ Max.
Solderability	Tip of solder tails and fitting nails into the molten solder (held at 245±5°C) up to 0.1mm from the bottom of the housing for 3±0.5 seconds.	Solder Wetting	95% of immersed area must show no voids, pin holes.
Resistance to Soldering	When reflowing refer to Infrared reflow condition <u>Soldering iron method</u> 0.2mm from terminal tip and fitting nail tip. Soldering time : 5 seconds Max. Solder temperature : 370~400°C	Appearance	No Damage

■ Recommended Temperature Profile

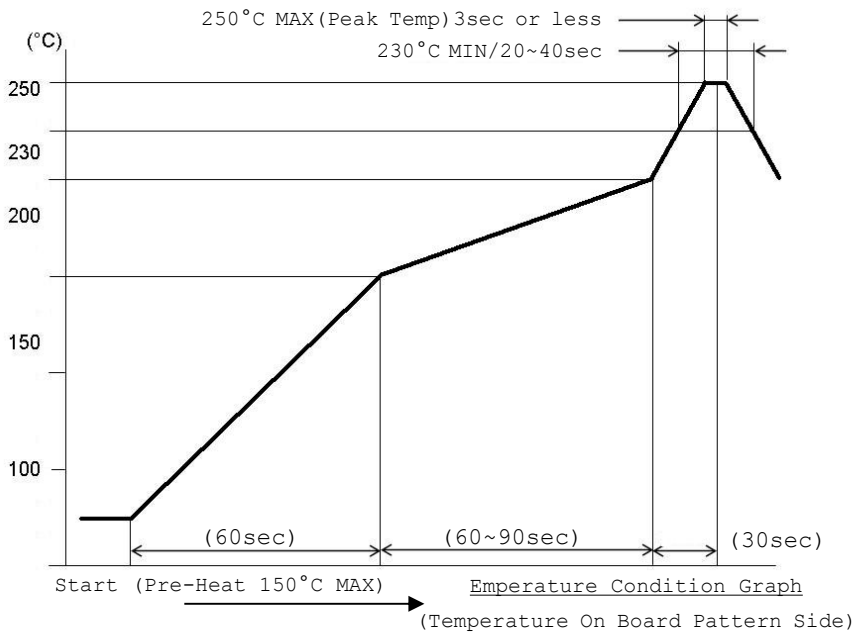

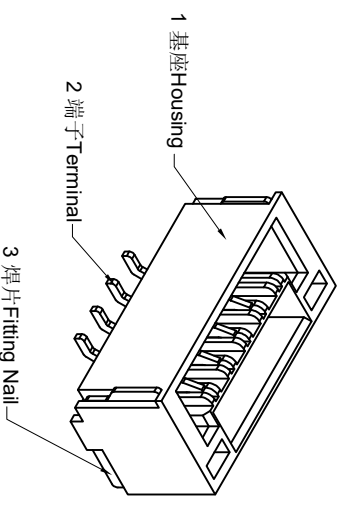
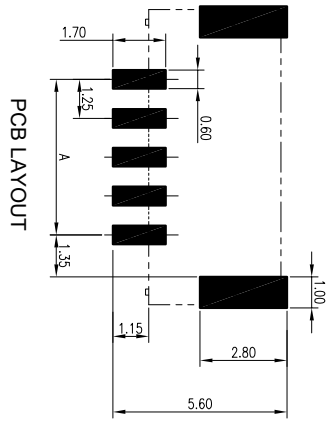
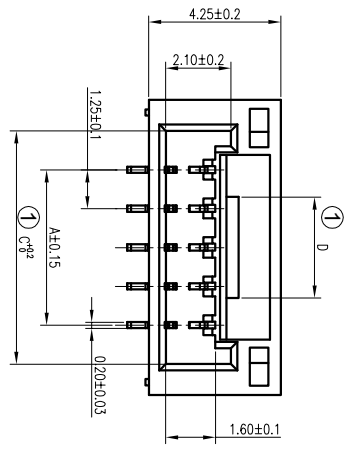
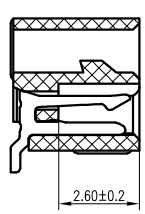
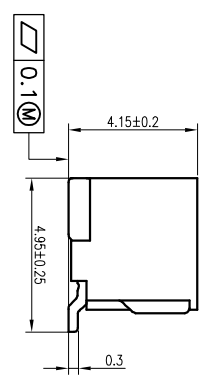
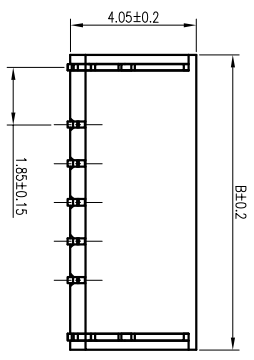

- 技术要求Notes:
- 外观质量Appearance quality:
 - 金属表面镀层不能有明显损伤; Coating on metal surface can not be damaged obviously;
 - 塑壳表面不能有明显的变形或开裂; No obvious deformation or cracking can be observed on the surface of the Housing;
 - 产品表面应保持清洁; Product surface should be kept clean;
 - 工作温度 Working temperature: -25℃~+85℃;
 - 额定电压 Voltage Rating : Max 50V [A/C(Effective value rms)/DC];
 - 额定电流 Current Rating : Max 1A [A/C(Effective value rms)/DC];
 - 接触电阻 Contact resistance: Max 20 mΩ
 - 绝缘电阻 Insulation resistance: Min 100MΩ;
 - 耐压 Withstanding voltage: 500V AC(50 Hz, Effective value: 1 min);
 - 环保要求应符合RoHS标准 Environmental requirements should meet RoHS standards.

表1 Table 1

16	18.75	23.25	21.25	6.5
15	17.50	22.00	20.00	6.5
14	16.25	20.75	18.75	6.5
13	15.00	19.50	17.50	6.5
12	13.75	18.25	16.25	6.5
11	12.50	17.00	15.00	6.5
10	11.25	15.75	13.75	6.5
9	10.00	14.50	12.50	4.5
8	8.75	13.25	11.25	4.5
7	7.50	12.00	10.00	4.5
6	6.25	10.75	8.75	4.5
5	5.00	9.50	7.50	3.25
4	3.75	8.25	6.25	2.00
3	2.50	7.00	5.00	1.75
2	1.25	5.75	3.75	0.5
PIN数 CKT NO.	DIM A	DIM B	DIM C	DIM D

表2 Table 2

3	THD1253	焊片 Fitting Nail	磷铜 Phosphor copper	2	镀锡 Tin-plated	
2	THD1253	端子 Terminal	磷铜 Phosphor copper	N	镀锡 Tin-plated	
1	THD1253	基座 Housing	LCP UL94-V0	1	本色 Natural color	
序号 No.	产品料号 PARTS NO.	名称 Part Name	材料 Material	数量 Qty	备注 Remark	

REV.	REVISIONS	CHK	DATE

CUSTOMER

SHENZHENSHI THD TECHNOLOGY CO., LTD.

深圳市壹華達科技有限公司

THD1253xW-SN

SCALE: 1:1

SIZE: A4

REV: X1

DATE: 2016.06.28

1.25mm厚胶圈带扣立贴

X-ON Electronics

Largest Supplier of Electrical and Electronic Components

Click to view similar products for [Headers & Wire Housings](#) category:

Click to view products by [THD](#) manufacturer:

Other Similar products are found below :

[57102-F02-18ULF](#) [58102-G61-06LF](#) [582553-1](#) [009176003701906](#) [01.001.5753.1](#) [0050291907](#) [02.125.8002.8](#) [609-3404](#) [61062-3](#)
[CSU011177004](#) [622-0430](#) [622-3653LF](#) [63453-116](#) [636-1030](#) [636-1427](#) [636-3427](#) [636-4007](#) [641938-9](#) [644827-2](#) [65495-038](#) [65692-001LF](#)
[65781-018](#) [65781-047](#) [65817-010LF](#) [65817-015LF](#) [66207-023LF](#) [67095-007LF](#) [67601157](#) [68631-112](#) [68645-018](#) [699319-000](#)
[M90C108951C](#) [70.362.1628.0](#) [70-4210](#) [70-4226B](#) [70-4853B](#) [707-5028](#) [71.350.2428.0](#) [71961-016LF](#) [733-134](#) [733-162](#) [754199-000](#) [760-](#)
[3052](#) [80.063.4001.1](#) [800-90-001-10-001000](#) [800-90-010-10-002000](#) [801-43-002-10-013000](#) [801-43-006-10-002000](#) [803-41-018-10-001000](#)
[803-43-024-10-001000](#)