

THINKING ELECTRONIC INDUSTRIAL CO., LTD.

HEAD OFFICE: 12F, No.93, Dashun 1st Rd., Zuoying Dist., Kaohsiung, Taiwan

TEL: 886-7-5577660 FAX: 886-7-5570560

MANUFACTURING SITE

- KAOHSIUNG FACTORY 1: No. 51, Kaifa Rd., N.E.P.Z, Kaohsiung City 81170, Taiwan
TEL: 886-7-9616668 FAX: 886-7-9616698
- KAOHSIUNG FACTORY 2: No. 2-2, Xinjian S. Rd., N.E.P.Z., Kaohsiung City 81170, Taiwan
TEL: 886-7-9630001 FAX: 886-7-3635113
- CHANGZHOU FACTORY: No.6 Longmen Rd., Wujin High & New-Tech Industrial
Development Zone, Changzhou, Jiangsu, China 213161
TEL:86-519-86578999 FAX:86-519-86558643
- DONG GUAN FACTORY: No.45, East Rd., Sha-Tao Dist., Chang-An Town,
Dongguan City, Guangdong, China 523863
TEL:86-769-85542016 FAX:86-769-85546890
- YICHANG FACTORY: No. 283 Xiaoting Avenue, Xiaoting Dist., Yichang
City 443007, Hubei, China
TEL:86-717-6510010 FAX:86-717-6511430



SPECIFICATION FOR APPROVAL

CUSTOMER 立創電子

CERTIFIED _____

MODEL/TYPE _____

PART NO. TPM0C102P115RS (RoHS+HF)

APPLICATION _____

CUSTOMER P/N _____

ISSUE DATE Jul. 22, 2022

REV. NO. _____

REV. DATE _____

FOR CUSTOMER APPROVAL	CHECKED BY
	<i>Shu Ling Fu</i>
	APPROVED BY
	<i>Chun Chu Tu</i>





REVISED RECORD SHEET

REV. NO	REV. DATE	REVISED CONTENT



INDEX	Page
■ Part Number Code	1
■ Structure and Dimensions	2
■ Electrical Characteristics	2
■ Reliability	3 ~ 5
■ Soldering Recommendation	6
■ Recommended Soldering Pad Dimensions	7
■ RoHS Compliant Declaration	7
■ Warehouse Storage Conditions of Products	7
■ Packaging	8
■ Certificates & Test Report	9
■ R-T Characteristic Curve	10

Part Number Code

Example :

TPM **0** **C** **102** **P** **115** **R** **S**
(1) (2) (3) (4) (5) (6) (7) (8)

No.	Item	Digit	Specification
(1)	Product Type	TPM	Thinking CPTC thermistor TPM type
(2)	Size (EIA)	0	0402
(3)	Type Series	C	Sensing Automotive Series
(4)	Zero Power Resistance at 25°C	102	$10 \times 10^2 = 1K\Omega$
(5)	Tolerance of R ₂₅	P	± 50%
(6)	Sensing Temperature	115	T _s =115°C
(7)	Packaging	R	Reel
(8)	Optional Suffix	S	Dual Sensing Temperature Product

Structure and Dimensions

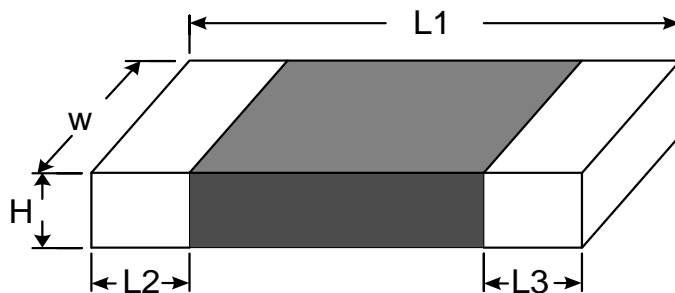

(unit : mm)

L1	W	H	L2 and L3
1.00±0.15	0.50±0.10	0.50±0.10	0.20±0.10

Electrical Characteristics

Part No.	Zero Power Resistance at 25°C	Sensing Temp.1 @ 10KΩ	Sensing Temp.2 @ 100KΩ	Max. Voltage	Operating Temperature
	R ₂₅ (KΩ)	Ts1 (°C)	Ts2 (°C)	V _{max.} (V _{DC})	(°C)
TPM0C102P115RS	1±50%	115±5	130±5	32	-40 ~ +140

Reliability

Tests of SMD PTC thermistors are based on AEC-Q200 Rev-C.

1、Preconditioning Reflow Requirements Before Reliability Stress Testing

Required Reliability Stress Tests after Preconditioning	Temperature Cycling	Operational Life	Thermal Shock	Terminal Strength	Board Flex
Number of reflow passes required onto test boards	2	2	2	2	2

2、Table of Test Methods

Item	Standard	Test conditions / Methods	Specifications																																										
High Temperature Exposure (Storage)	MIL-STD-202 Method 108	Test temp.: Tmax. +3/-0°C Duration: 1000 h Unpowered Measurement at 24±2 hours after test conclusion.	No visible damage $\Delta R_{25}/R_{25}$ $\leq 20\%$																																										
Temperature Cycling	JESD22 Method JA-104	Lower test temp. : -40 +0/-3°C Upper test temp. : 125 +3/-0°C Soak Time at Lower or Upper Temp. : 1 min Cycle time : 2 Cycles/hr Number of cycles : 1000 Measurement at 24±2 hours after test conclusion.	No visible damage $\Delta R_{25}/R_{25}$ $\leq 20\%$																																										
Moisture Resistance	MIL-STD-202 Method 106	Duration of 1 cycle: 24 h Number of cycles: 10 · Unpowered Measurement at 24±2 hours after test conclusion. <table border="1" data-bbox="539 1619 1123 1982"> <thead> <tr> <th rowspan="2">Step</th> <th colspan="2">Temp.</th> <th rowspan="2">humidity (%)</th> <th rowspan="2">Period (hr)</th> </tr> <tr> <th>Start</th> <th>Finish</th> </tr> </thead> <tbody> <tr> <td>1</td> <td>25</td> <td>65</td> <td>90~100</td> <td>2.5</td> </tr> <tr> <td>2</td> <td>65</td> <td>65</td> <td>90~100</td> <td>3</td> </tr> <tr> <td>3</td> <td>65</td> <td>25</td> <td>80~100</td> <td>2.5</td> </tr> <tr> <td>4</td> <td>25</td> <td>65</td> <td>90~100</td> <td>2.5</td> </tr> <tr> <td>5</td> <td>65</td> <td>65</td> <td>90~100</td> <td>3</td> </tr> <tr> <td>6</td> <td>65</td> <td>25</td> <td>80~100</td> <td>2.5</td> </tr> <tr> <td>7</td> <td>25</td> <td>25</td> <td>80~100</td> <td>8</td> </tr> </tbody> </table>	Step	Temp.		humidity (%)	Period (hr)	Start	Finish	1	25	65	90~100	2.5	2	65	65	90~100	3	3	65	25	80~100	2.5	4	25	65	90~100	2.5	5	65	65	90~100	3	6	65	25	80~100	2.5	7	25	25	80~100	8	No visible damage $\Delta R_{25}/R_{25}$ $\leq 20\%$
Step	Temp.			humidity (%)	Period (hr)																																								
	Start	Finish																																											
1	25	65	90~100	2.5																																									
2	65	65	90~100	3																																									
3	65	25	80~100	2.5																																									
4	25	65	90~100	2.5																																									
5	65	65	90~100	3																																									
6	65	25	80~100	2.5																																									
7	25	25	80~100	8																																									

Reliability

2、Table of Test Methods

Item	Standard	Test conditions / Methods	Specifications
Biased Humidity	MIL-STD-202 Method 103	Test temp.: 85°C Rel. humidity of air: 85% Duration: 1000 h Bias at Max. Voltage V_{max} (V_{DC}) Measurement at 24±2 hours after test conclusion.	No visible damage $ \Delta R_{25}/R_{25} \leq 20\%$
Operational Life	MIL-STD-202 Method 108	Test temp.: $T_{max.} +3/-0^{\circ}C$ Duration: 1000 h Bias at Max. Voltage V_{max} (V_{DC}) Measurement at 24±2 hours after test conclusion.	No visible damage $ \Delta R_{25}/R_{25} \leq 20\%$
External Visual	MIL-STD-883 Method 2009	Inspect device construction, marking and workmanship.	No visible damage
Physical Dimension	JESD22 Method JB-100	Verify physical dimensions to the applicable device specification.	Within the specified values
Resistance to Solvents	MIL-STD-202 Method 215	Per MIL-STD-202 Method 215 Solvent 1: 1 part (by volume) of isopropyl alcohol 3 part (by volume) of mineral spirits.	No visible damage
Mechanical Shock	MIL-STD-202-213	Test Condition F Peak value : 1500g's Half sine Waveform Normal duration (D) : 0.5ms In 3 directions perpendicularly intersecting each other (total 18 times).	No visible damage $ \Delta R_{25}/R_{25} \leq 20\%$
Vibration	MIL-STD-202 Method 204	Acceleration : 5 g's Sweep time: 20 min Frequency range: 10 to 2000 Hz 3×12 cycles	No visible damage $ \Delta R_{25}/R_{25} \leq 20\%$
Resistance to Soldering Heat	MIL-STD-202 Method 210	Condition B No pre-heat of samples. Temperature : $260 \pm 5^{\circ}C$, Time : $10 \pm 1s$ Immersion and emersion rate : 25mm/s ±6 mm/s Number of heat cycles : 1	No visible damage $ \Delta R_{25}/R_{25} \leq 20\%$
Thermal Shock	MIL-STD-202 Method 107	Lower test temp. : $-40 +0/-3^{\circ}C$ Upper test temp. : $125 +3/-0^{\circ}C$ Maximum transfer time : 20 seconds. Dwell time : 15 minutes. Air-Air. Number of cycles : 300	No visible damage $ \Delta R_{25}/R_{25} \leq 20\%$

Reliability

2、Table of Test Methods

Item	Standard	Test conditions / Methods	Specifications
ESD	AEC-Q200 -002	Discharge capacitance : 150 pF Charging voltage: 6 kV Contact discharge 1 pulse in each polarity	No visible damage $ \Delta R_{25}/R_{25} \leq 20\%$
Solderability	IEC 60068-2- 58 J-STD-002	a) 4 h @ 155°C dry heat Dip @245±5°C 3±0.3sec b) Steam aging 8h±15min @93±3°C Dip @260±5°C 7±0.5sec	95% of termination wetted
Electrical Characterization	Specifications	Ta1:25±2°C Ta2:[Tsx + □°C]±0.1°C Ta3:[Tsx - □°C]±0.1°C	Within the specified values
Board Flex	AEC-Q200 -005 (JIS-C-6429)	Bend the board : 2mm (Min.) Duration : 60 (+5) Sec	No visible damage $ \Delta R_{25}/R_{25} \leq 10\%$
Terminal Strength	AEC-Q200 -006 (JIS-C-6429)	Apply force : 0.5kg (5 N) Duration of the applied forces : 60 (+1) Sec	No visible damage $ \Delta R_{25}/R_{25} \leq 20\%$

Soldering Recommendation

■ IR-Reflow Soldering Profile

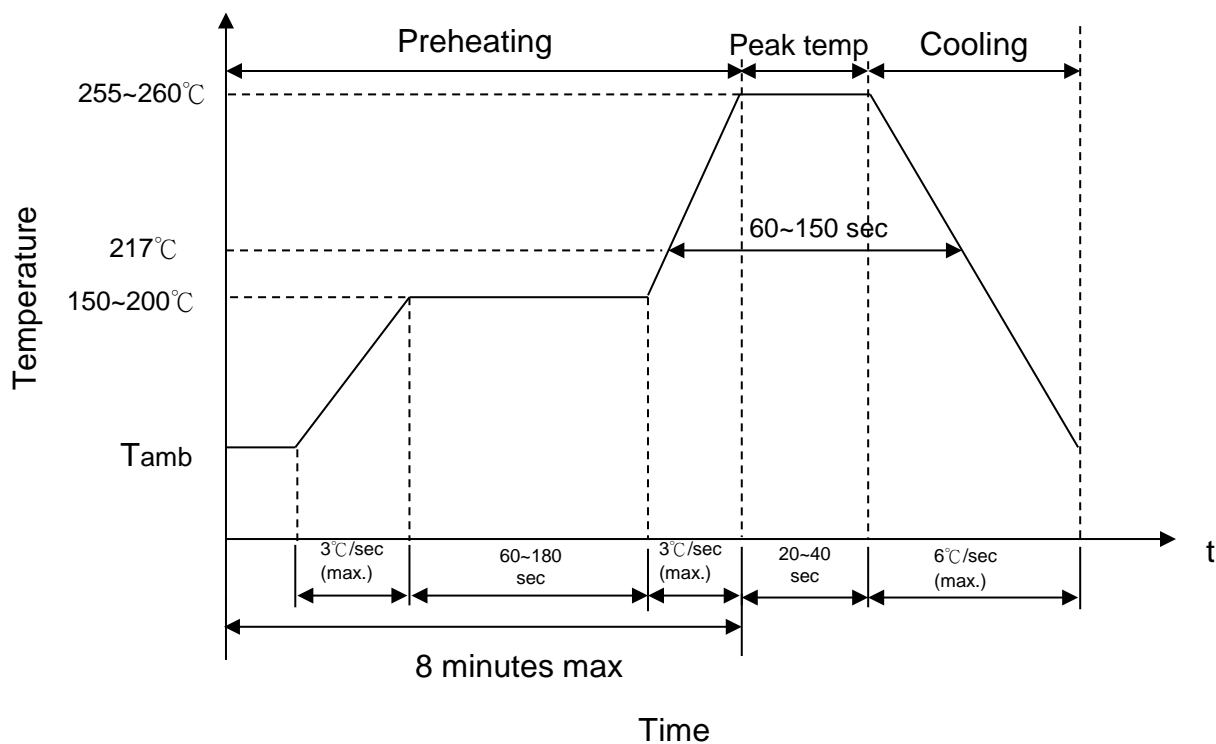

■ Recommended Reworking Conditions with Soldering Iron

Item	Conditions
Temperature of Soldering Iron-tip	360°C (max.)
Soldering Time	3 sec (max.)
Diameter of Soldering Iron-tip	$\phi 3\text{mm}$ (max.)
Caution: Not to touch the component surface with soldering iron directly to prevent component damage.	

Recommended Soldering Pad Dimensions

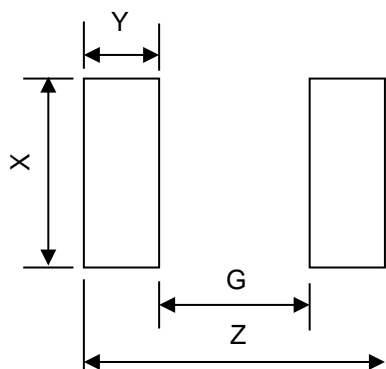

Size (EIA)	0402
Z	1.7 mm
G	0.5 mm
X	0.6 mm
Y	0.6 mm

RoHS Compliant Declaration

We hereby declare that the components delivered to your company are compliant with RoHS directive 2015/863/EU.

Warehouse Storage Conditions of Products

(I) Storage Conditions :

- 1.Storage Temperature : -10°C ~+40°C
- 2.Relative Humidity : $\leq 75\%RH$
- 3.Keep away from corrosive atmosphere and sunlight.

(II) Period of Storage : 1 year

Packaging

■ Taping Specification (0402 Series)

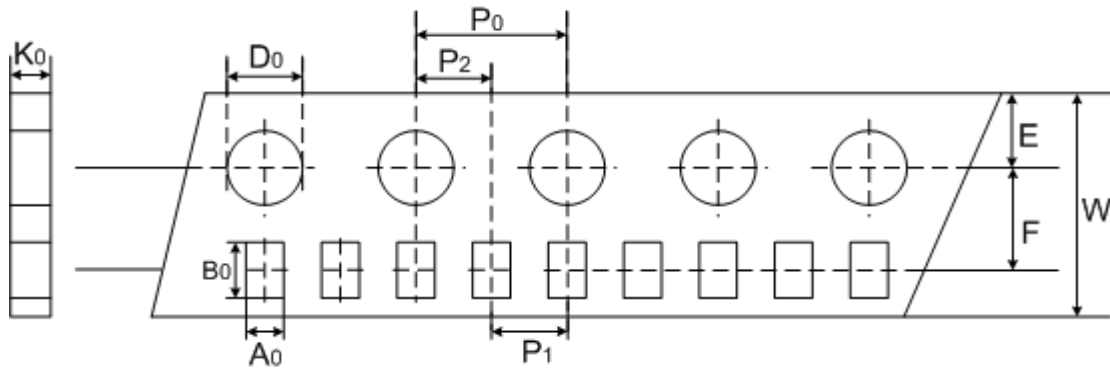

(Unit : mm)

Index	A_0	B_0	W	E	F	P_1	P_2	P_0	D_0	K_0
Size	± 0.05	± 0.12	± 0.2	± 0.1	± 0.05	± 0.1	± 0.05	± 0.1	± 0.1	± 0.1
0402	0.62	1.12	8.0	1.75	3.5	2.0	2.0	4.0	1.55	0.60

■ Quantity (10000 pcs / reel)

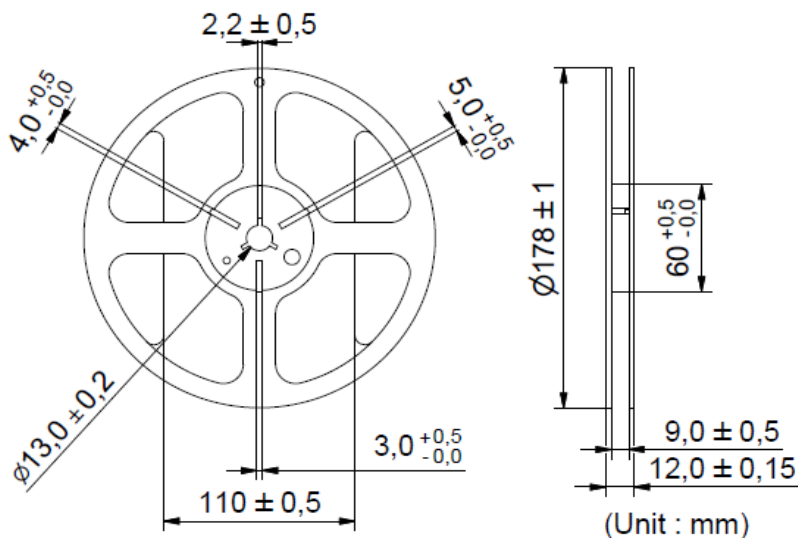

(Unit : mm)

Certificates

- (1) IATF 16949 certificate
- (2) ISO 9001 certificate
- (3) QC 080000 certificate

Test Report

- (1) RoHS test report
- (2) Halogen-free test report



R-T Characteristic Curve

TPM0C102P115RS

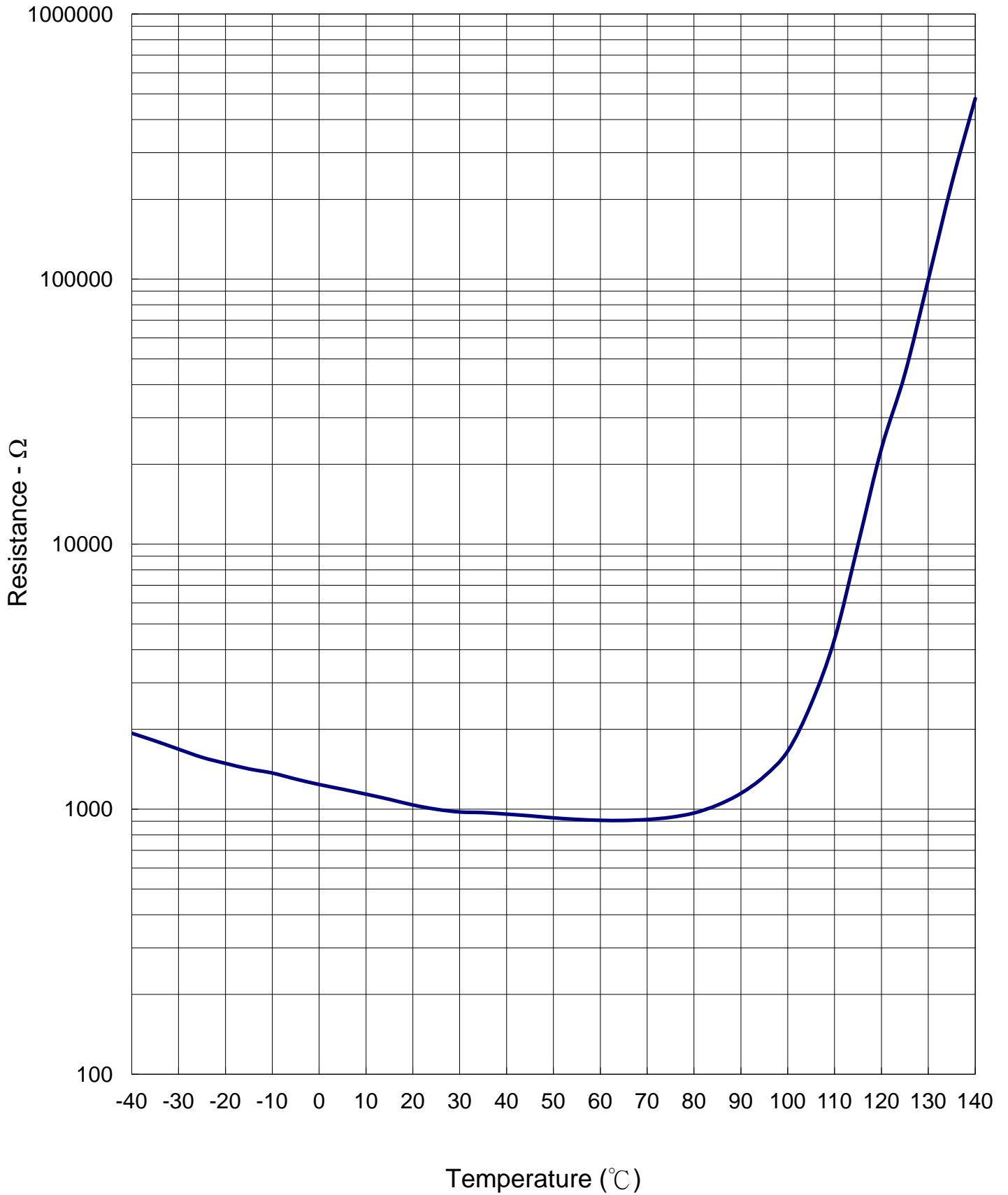

X-ON Electronics

Largest Supplier of Electrical and Electronic Components

Click to view similar products for [PTC \(Positive Temperature Coefficient\) Thermistors](#) category:

Click to view products by [TKS](#) manufacturer:

Other Similar products are found below :

[PTCCL09H251FBE](#) [PTCTL3MR100GTE](#) [B59346A1502P020](#) [B59860C 130A 70](#) [B59980C0160A070](#) [PTCTT95R100GTE](#)
[PTCLL05P131TBE](#) [B59841C0135A070](#) [PTCCL09H541DBE](#) [TFPT0805L1800FV](#) [B59725T1120A062](#) [B59008C0150A040](#)
[B59100M1090A070](#) [B59100M1145A070](#) [B59873C0120A070](#) [B59990C0080A070](#) [B59300M1150A070](#) [B59339A1501P020](#)
[B59770B0120A070](#) [TPM0S102P125RT](#) [TPM0C102P115RS](#) [TPM1S471N105R-H](#) [B59955C0120A070](#) [B59985C0120A070](#)
[B59995C0120A070](#) [YQR100R060](#) [YQS5751PTO](#) [YQS5856PTF](#) [YQS5930PTO](#) [YS5675](#) [YS5918PTO](#) [YS5677](#) [YQS5898PTO](#)
[YQS5868PTF](#) [YQD100N1000](#) [KTY82/222,215](#) [KTY81/110,112](#) [KTY81/210,112](#) [B59219J130A20](#) [B59771B0120A070](#) [B59807A90A62](#)
[B59830C120A70](#) [B59005Z999A99](#) [B59641A0135A062](#) [B59874C120A70](#) [B59960C160A70](#) [PTGL10ARR27M1B51A0](#) [P5005C090S500H](#)
[YQD120N0025](#) [PTGL12AS4R7K6B51B0](#)