



# THINKING ELECTRONIC INDUSTRIAL CO., LTD.

HEAD OFFICE: 12F, No.93, Dashun 1st Rd., Zuoying Dist., Kaohsiung, Taiwan  
TEL: 886-7-5577660 FAX: 886-7-5570560

## MANUFACTURING SITE

- KAOHSIUNG FACTORY 1: No. 51, Kaifa Rd., N.E.P.Z, Kaohsiung City 81170, Taiwan  
TEL: 886-7-9616668 FAX: 886-7-9616698
- KAOHSIUNG FACTORY 2: No. 2-2, Xinjian S. Rd., N.E.P.Z., Kaohsiung City 81170, Taiwan  
TEL: 886-7-9630001 FAX: 886-7-3635113
- CHANGZHOU FACTORY: No.6 Longmen Rd., Wujin High & New-Tech Industrial  
Development Zone, Changzhou, Jiangsu, China 213161  
TEL: 86-519-86578999 FAX: 86-519-86558643
- DONG GUAN FACTORY: No.45, East Rd., Sha-Tao Dist., Chang-An Town,  
Dongguan City, Guangdong, China 523863  
TEL: 86-769-85542016 FAX: 86-769-85546890
- YICHANG FACTORY: No. 283 Xiaoting Avenue, Xiaoting Dist., Yichang  
City 443007, Hubei, China  
TEL: 86-717-6510010 FAX: 86-717-6511430



## SPECIFICATION FOR APPROVAL

CUSTOMER \_\_\_\_\_

CERTIFIED  
MODEL/TYPE

TVR05431

PART NO.

TVR05431KSARY(RoHS)

APPLICATION \_\_\_\_\_

CUSTOMER P/N \_\_\_\_\_

ISSUE DATE

Jun.12.2020

REV. NO. \_\_\_\_\_

REV. DATE \_\_\_\_\_

FOR CUSTOMER APPROVAL	CHECKED BY
	Yuan Yuan
	APPROVED BY
	Huaifang Zhang





**REVISED RECORD SHEET**

REV. NO	REV. DATE	REVISED CONTENT



<b>INDEX</b>	<b>Page</b>
■ Part Number Code	1
■ Structure and Dimensions	2
■ Electrical Characteristics	2
■ Reliability	3 ~ 4
■ Soldering Recommendation	5
■ Power Derating Curve	6
■ RoHS Compliant Declaration	6
■ Warehouse Storage Conditions of Products	6
■ Taping and Dimensions	7
■ Packaging	8
■ Certificates	9
■ Max. Surge Current Derating Curves	10
■ Max. Leakage Current and Max. Clamping Voltage Curve	11

Part Number Code

Example :

**TVR**    **05**    **431**    **K**    **S**    **AR**    **Y**  
 (1)        (2)        (3)        (4)        (5)        (6)        (7)

No.	Item	Digit	Specification
(1)	Product Type	TVR	Thinking varistor TVR type
(2)	Body Size	05	φ 05 mm
(3)	Varistor Voltage	431	$43 \times 10^1 \text{ V} = 430\text{V (V1mA)}$
(4)	Tolerance of $V_{1\text{mA}}$	K	±10%
(5)	Appearance	S	Straight Lead , Epoxy Coating
(6)	Packaging	A	Repositioning tapping( hole pitch: 12.7mm)
		R	reel
(7)	Optional Suffix	Y	RoHS compliance

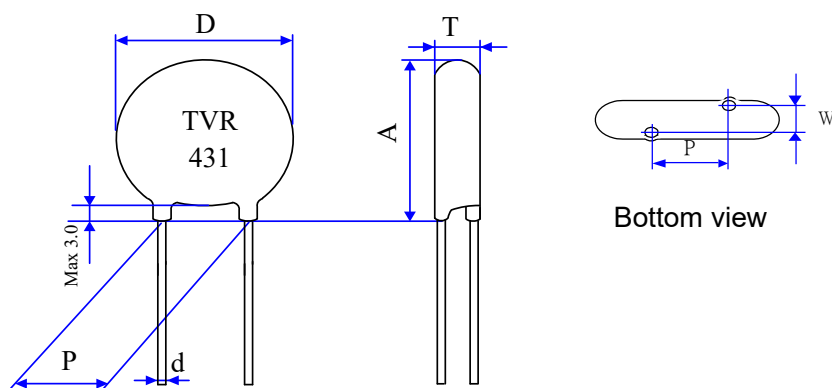
**Structure and Dimensions**

( unit : mm )

Body Size	D	P	d	A max.	T	W
$\phi 05$	5.0~7.0	$5.0 \pm 0.5$	$0.60 \pm 0.02$	9.0	3.0~5.1	$2.3 \pm 1.0$

**\*Coating material rating:UL 94 V-0**
**Electrical Characteristics ( Ambient  $T_a=25^\circ\text{C}$  )**

Part No.	Varistor Voltage (@ 1mA DC)	Max. Continuous Voltage		Max. Clamping Voltage (8/20 $\mu$ S)		Max. Surge Current (8/20 $\mu$ S)	Max. Energy (10/1000 $\mu$ S)
	$V_{1mA}$ (V)	$V_{AC}(rms)$ (V)	$V_{DC}$ (V)	$V_p$ (V)	$I_p$ (A)	$I$ (A)	$W$ (J)
TVR05431KSARY	$430 \pm 10 \%$	275	350	745	5	400	13

Part No.	Rated Power	Impulse Response Time	Max. Leakage Current at 75% $V_{1mA}$	Operating Temperature Range	Storage temperature Range
	P (W)	nSec	$I_L(\mu A)$	( $^\circ\text{C}$ )	( $^\circ\text{C}$ )
TVR05431KSARY	0.1	<25	20	-40 ~ +85	-40 ~ +125

**Reliability**

Item	Standard	Test conditions / Methods	Specifications															
Tensile Strength of Terminals	IEC60068-2-21	Gradually applying the force specified and keeping the unit fixed for 10±1 sec.  <table style="margin-left: auto; margin-right: auto;"> <tr> <td style="text-align: center;">Terminal diameter (mm)</td> <td style="text-align: center;">Force (Kg)</td> </tr> <tr> <td style="text-align: center;">0.5&lt;d≤0.8</td> <td style="text-align: center;">1.0</td> </tr> <tr> <td style="text-align: center;">0.8&lt;d≤1.25</td> <td style="text-align: center;">2.0</td> </tr> <tr> <td style="text-align: center;">1.25&lt;d</td> <td style="text-align: center;">4.0</td> </tr> </table>	Terminal diameter (mm)	Force (Kg)	0.5<d≤0.8	1.0	0.8<d≤1.25	2.0	1.25<d	4.0	No visible damage   $\Delta V/V_{1mA}$   ≤5%							
Terminal diameter (mm)	Force (Kg)																	
0.5<d≤0.8	1.0																	
0.8<d≤1.25	2.0																	
1.25<d	4.0																	
Bending Strength of Terminals	IEC60068-2-21	Hold specimen and apply the force specified below to each lead. Bend the specimen to 90°, then return to the original position. Repeat the procedure in the opposite direction.  <table style="margin-left: auto; margin-right: auto;"> <tr> <td style="text-align: center;">Terminal diameter (mm)</td> <td style="text-align: center;">Force (Kg)</td> </tr> <tr> <td style="text-align: center;">0.5&lt;d≤0.8</td> <td style="text-align: center;">0.5</td> </tr> <tr> <td style="text-align: center;">0.8&lt;d≤1.25</td> <td style="text-align: center;">1.0</td> </tr> <tr> <td style="text-align: center;">1.25&lt;d</td> <td style="text-align: center;">2.0</td> </tr> </table>	Terminal diameter (mm)	Force (Kg)	0.5<d≤0.8	0.5	0.8<d≤1.25	1.0	1.25<d	2.0	No visible damage   $\Delta V/V_{1mA}$   ≤5%							
Terminal diameter (mm)	Force (Kg)																	
0.5<d≤0.8	0.5																	
0.8<d≤1.25	1.0																	
1.25<d	2.0																	
Vibration	IEC 60068-2-6	Frequency range:10~55Hz Amplitude:0.75mm or 98m/S <sup>2</sup> Direction:3 mutually perpendicular directions,2hrs each.	$\Delta V/V_{1mA}$   ≤5% No visible damage															
Solderability	IEC60068-2-20	245 ± 3 °C , 3 ± 0.3 sec	At least 95% of terminal electrode is covered by new solder															
Resistance to Soldering Heat	IEC60068-2-20	260 ± 3 °C , 5 ± 1 sec	No visible damage   $\Delta V/V_{1mA}$   ≤5%															
High Temperature Storage	IEC60068-2-2	125 ± 5 °C , 1000 ± 24 hrs	No visible damage   $\Delta V/V_{1mA}$   ≤5%															
Damp Heat, Steady State	IEC 60068-2-78	The test is divided into two groups . a.40 ± 2°C , 90 ~ 95 % RH , 1344 hrs b.40 ± 2°C , 90 ~ 95 % RH , at 10%V <sub>DC</sub> , 1344 hrs	No visible damage   $\Delta V/V_{1mA}$   ≤10% Insulation Resistance ≥ 100MΩ															
Rapid Change of Temperature	IEC60068-2-14	The conditions shown below shall be repeated 5 cycles  <table border="1" style="margin-left: auto; margin-right: auto;"> <thead> <tr> <th>Step</th> <th>Temperature (°C)</th> <th>Period (minutes)</th> </tr> </thead> <tbody> <tr> <td style="text-align: center;">1</td> <td style="text-align: center;">-40 ± 3</td> <td style="text-align: center;">30 ± 3</td> </tr> <tr> <td style="text-align: center;">2</td> <td style="text-align: center;">Room temperature</td> <td style="text-align: center;">5 ± 3</td> </tr> <tr> <td style="text-align: center;">3</td> <td style="text-align: center;">85 ± 2</td> <td style="text-align: center;">30 ± 3</td> </tr> <tr> <td style="text-align: center;">4</td> <td style="text-align: center;">Room temperature</td> <td style="text-align: center;">5 ± 3</td> </tr> </tbody> </table>	Step	Temperature (°C)	Period (minutes)	1	-40 ± 3	30 ± 3	2	Room temperature	5 ± 3	3	85 ± 2	30 ± 3	4	Room temperature	5 ± 3	No visible damage   $\Delta V/V_{1mA}$   ≤5%
Step	Temperature (°C)	Period (minutes)																
1	-40 ± 3	30 ± 3																
2	Room temperature	5 ± 3																
3	85 ± 2	30 ± 3																
4	Room temperature	5 ± 3																
High Temp. Load	MIL-STD-202 Method 108	85 ± 2 °C , 1000 ± 24 hrs, at V <sub>DC</sub> or V <sub>rms</sub> (Max. Operating Voltage)	$\Delta V/V_{1mA}$   ≤10% No visible damage															



Item	Standard	Test conditions / Methods	Specifications
8/20 $\mu$ S Surge Life	IEC 61051-1 4.6	10 pulses( 8/20 $\mu$ S) , unipolar, interval 30 secs,amplitude corr. to max. Surge current derating curves for 20 $\mu$ S.	$ \Delta V/V_{1mA}  \leq 10\%$ No visible damage
10/1000 $\mu$ S Surge Life	IEC 61051-1 4.6	10/1000 $\mu$ S waveform, 10 surge currents,unipolar,interval 2mins, amplitude corr. to max. surge current derating curves for 1000 $\mu$ S	$ \Delta V/V_{1mA}  \leq 10\%$ No visible damage
Varistor Voltage Temp. Coefficient	Specification Standard	$\frac{V_{1mA} \text{ at } 85^{\circ}\text{C} - V_{1mA} \text{ at } 25^{\circ}\text{C}}{V_{1mA} \text{ at } 25^{\circ}\text{C}} \times \frac{1}{60} \times 100 (\% / ^{\circ}\text{C})$ $\frac{V_{1mA} \text{ at } -40^{\circ}\text{C} - V_{1mA} \text{ at } 25^{\circ}\text{C}}{V_{1mA} \text{ at } 25^{\circ}\text{C}} \times \frac{1}{65} \times 100 (\% / ^{\circ}\text{C})$	$-0.05 \leq TC \leq 0.05 (\% / ^{\circ}\text{C})$
Voltage Proof	IEC 61051-1 4.9	Metal balls method, 2500 Vac 1 min	No visible damage

## Soldering Recommendation

### Wave Soldering Profile

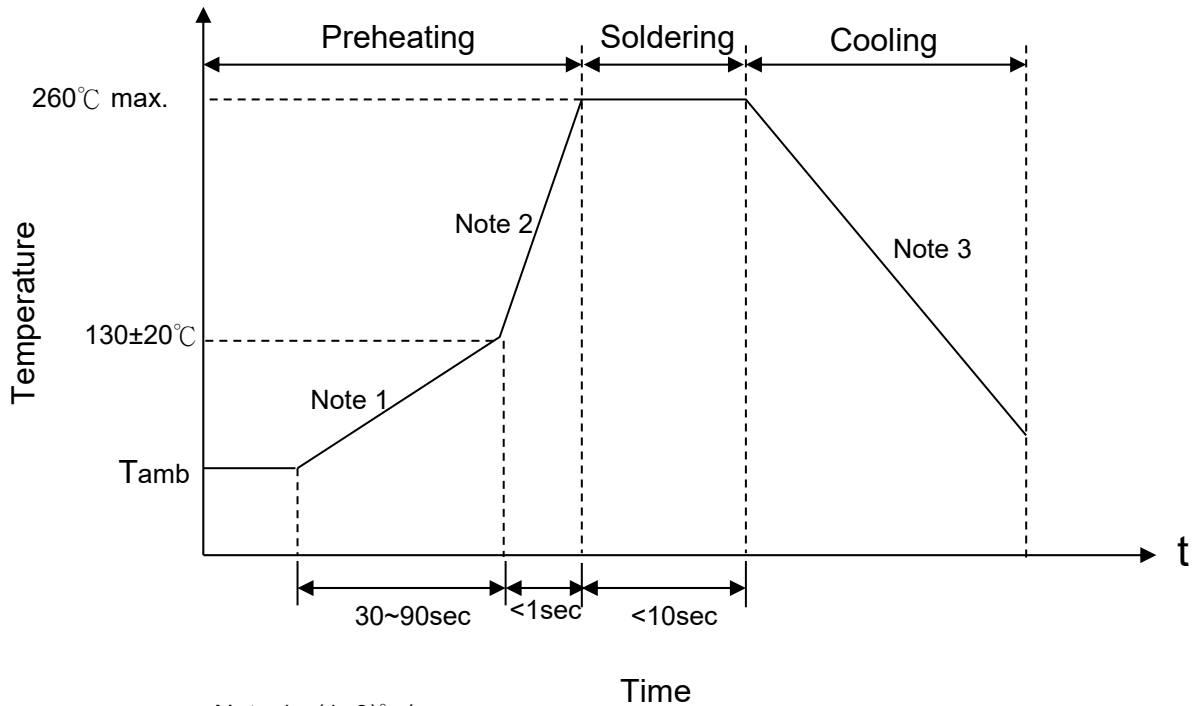

- Note 1 :  $(1\sim 3)^\circ\text{C/sec}$   
 Note 2 : Approx.  $200^\circ\text{C/sec}$   
 Note 3 :  $5^\circ\text{C/sec Max}$

### Recommended Reworking Conditions with Soldering Iron

Item	Conditions
Temperature of Soldering Iron-tip	$360^\circ\text{C (max.)}$
Soldering Time	3 sec (max.)
Distance from Varistor	2 mm (min.)



### Power Derating Curve

When operating temperature exceeds 85°C, the power, the Max.continuous operation Voltage,the Max.Surge Current and the Max.Energy should be derated as below figure, the derated coefficient is -2.5%.

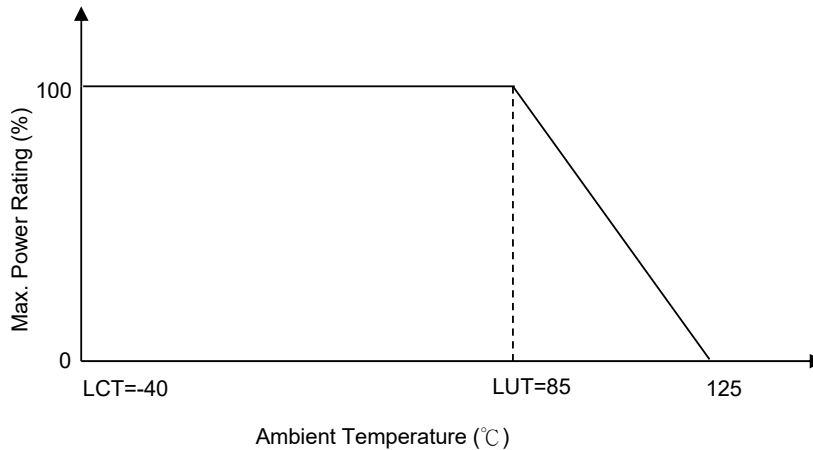

### RoHS Compliant Declaration

We hereby declare that the components delivered to your company are compliant with RoHS directive 2015/863/EU.

### Warehouse Storage Conditions of Products

(I) Storage Conditions :

- 1.Storage Temperature : -10°C~+40°C
- 2.Relative Humidity :  $\leq 75\%RH$
- 3.Keep away from corrosive atmosphere and sunlight.

(II) Period of Storage : 1 year

Taping and Dimensions

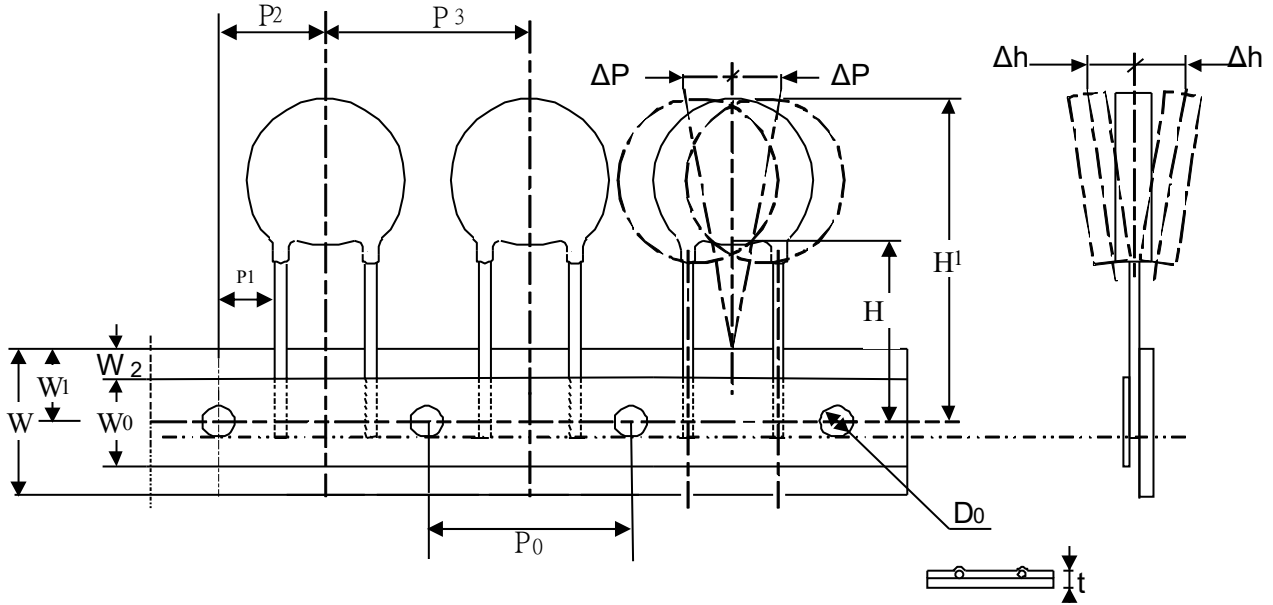

ITEM.	P <sub>0</sub>	P <sub>1</sub>	P <sub>2</sub>	P <sub>3</sub>	H	H <sub>1</sub> Max	W <sub>0</sub>	W <sub>1</sub>	W <sub>2</sub> Max	W	Δp Max	Δh Max	D <sub>0</sub>	t
Nor.	12.7	3.55	6.35	12.7	18	28	12	9	3	18	1.0	2.0	4	0.6
ToL.	±0.3	±1	±1.3	±1	+2/-0	---	±1	+0.75/ -0.5	---	±1	---	---	±0.2	±0.2

(Unit:mm)

Packaging

(1) SPQ: 1000 Pcs/ Reel

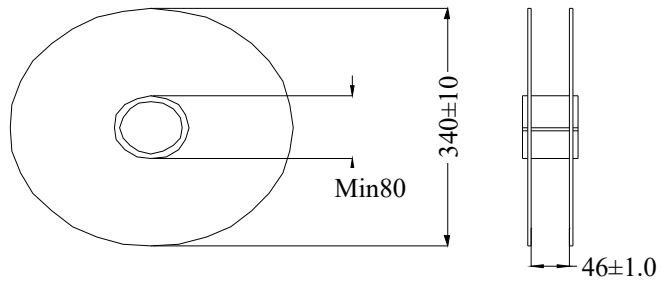

(2) Outer Box: 5Reels/ Carton

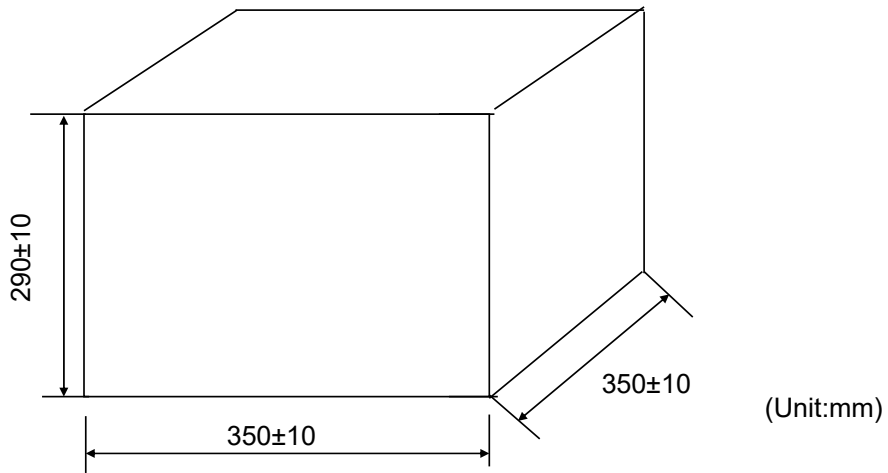

Safety Approvals (Certified Model/Type :TVR05431)

\* UL 1449 4th / cUL recognized (File # E314979)



\* TUV recognized (File J50411784)



\*CSA 22.2 recognized (File # 97495)



\*VDE IEC 61051-1:2007/IEC 61051-2:1991/ IEC 61051-2-2:1991  
DIN EN 61051-1:2009/IEC 61051-2 AMD1:2009(File # 5944)



\* CQC GB/T10193-1997 ` GB/T10194-1997 recognized  
(File # CQC03001005165/CQC03001007654)

Certificates

- (1) IATF 16949 certificate
- (2) ISO 9001 certificate

Test Report

- (1) RoHS test report



Max. Surge Current Derating Curves

TVR05431KSARY

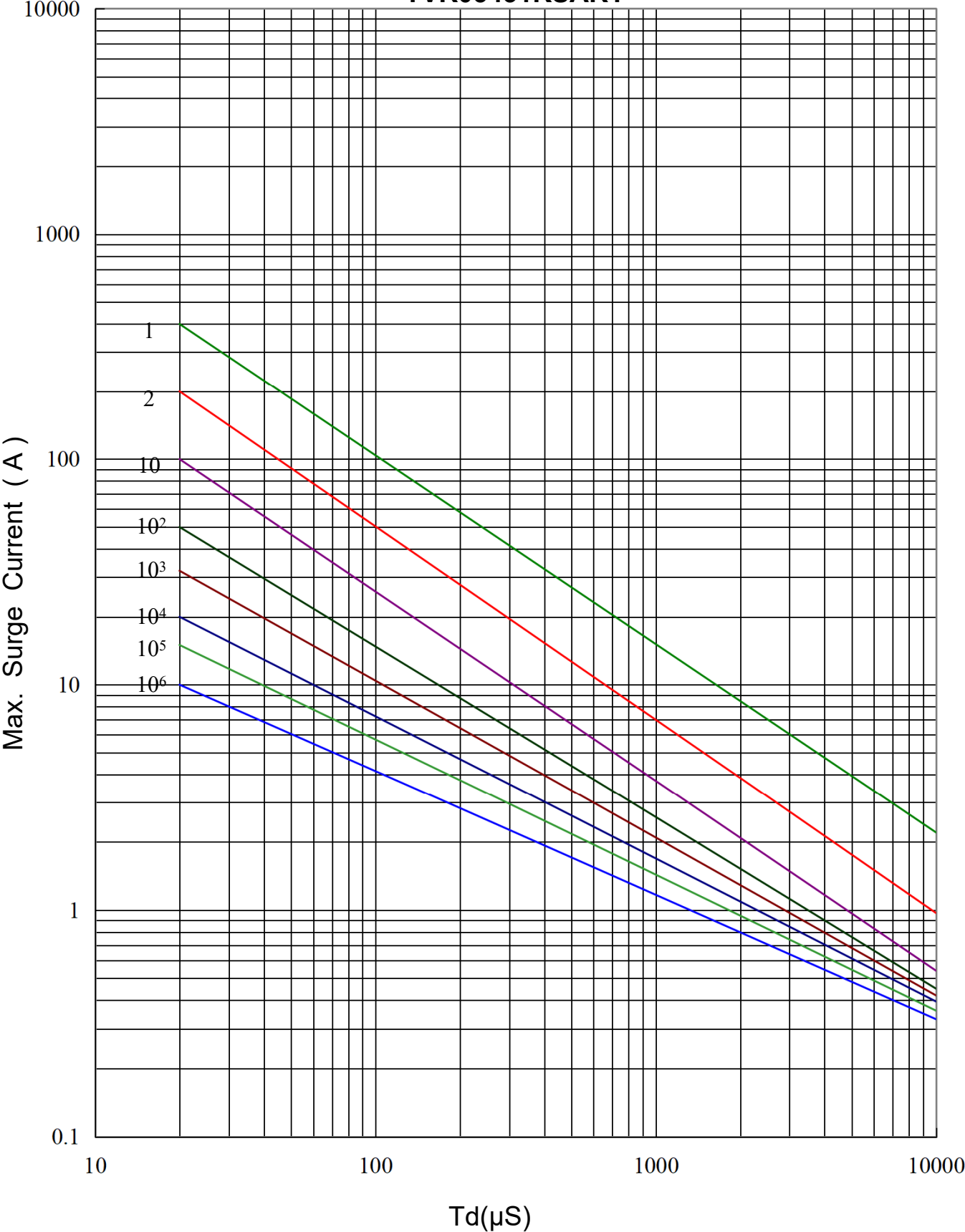



Max. Leakage Current and Max. Clamping Voltage Curve

TVR05431KSARY

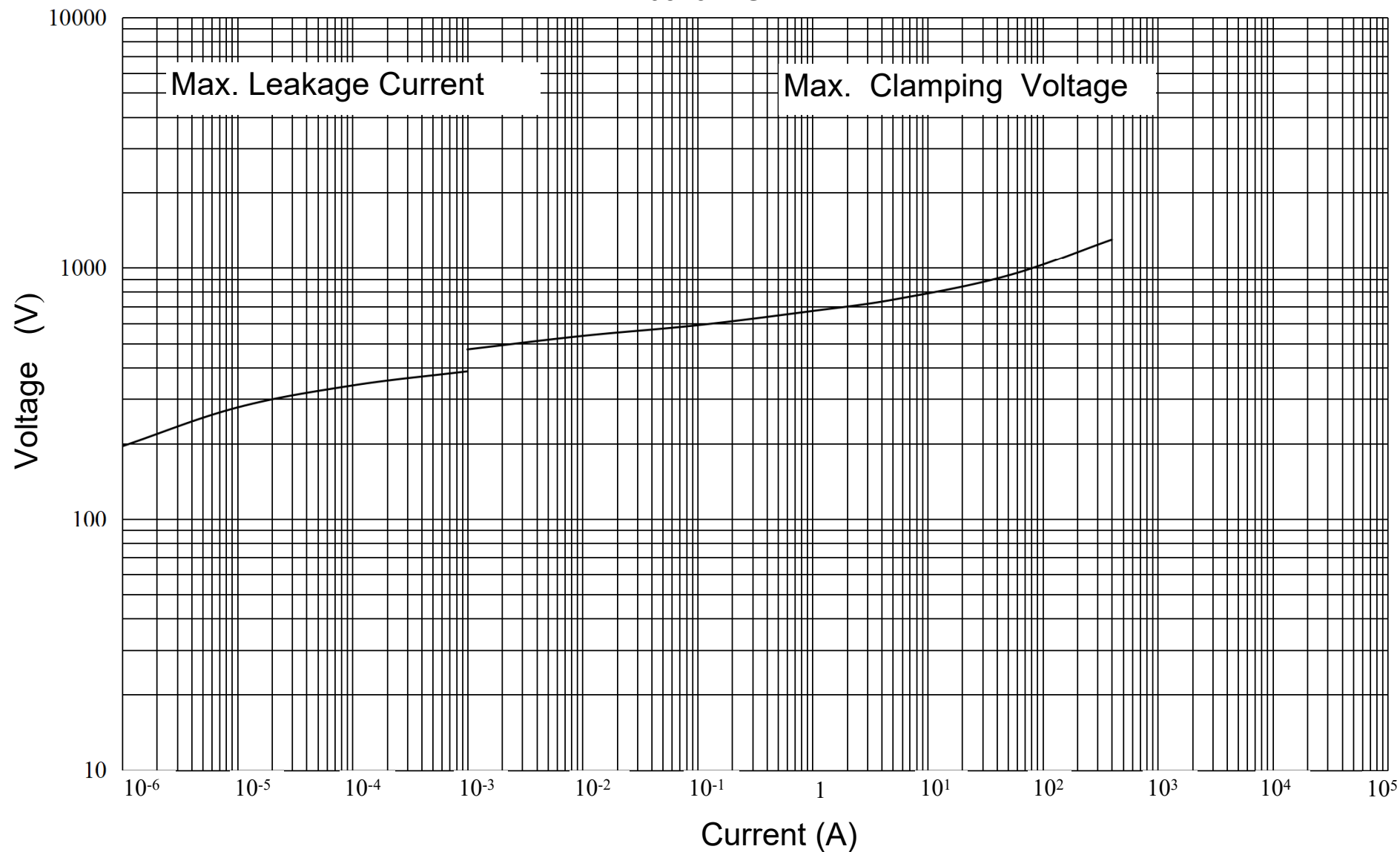

## X-ON Electronics

Largest Supplier of Electrical and Electronic Components

*Click to view similar products for [Varistors](#) category:*

*Click to view products by [TKS](#) manufacturer:*

Other Similar products are found below :

[820443211E](#) [MOV05131AIA](#) [MOV07231AQA](#) [MOV18131CZA](#) [R71ZOV151HC](#) [D58ZOV500RA01T1](#) [B72205S271K111](#)  
[B72214S110K151](#) [B72214S251K151](#) [B72232B131K1](#) [B72280B271K1](#) [B72530E1140S272](#) [B72540E250K62](#) [B72650M0151K093](#)  
[B72660M0271K093](#) [NTE1V020](#) [NTE1V130](#) [NTE2V010](#) [NTE2V130](#) [238159352716](#) [25FN511K](#) [S10K11G5S5](#) [ERZ-C14DK361U](#) [ERZ-](#)  
[C20DK221U](#) [ERZ-C32CK201B](#) [207869-1](#) [AS-13](#) [TMOV25SP625E](#) [TND10V-471KB00AAA0](#) [B72210S251K531](#) [B72214S200K551](#)  
[B72280B112K1](#) [B72280B381K1](#) [B72590D360A60](#) [B72650M301K93](#) [B72670M1140K72](#) [MOV07251ARA](#) [MOV10131EDA](#)  
[MOV10151EFA](#) [MOV14151CWA](#) [MOV20251DFA](#) [TVZ18EC271KBS](#) [TVZ20EB911KBS](#) [TVZ25D201KBS](#) [TVZ25D241KBS](#)  
[VDRH20X230BSE](#) [VZ07D220KBS](#) [VZ40D241K](#) [VZ25D511KBS-N](#) [VZ20E511KBSX](#)