



THINKING ELECTRONIC INDUSTRIAL CO., LTD.

HEAD OFFICE: 12F, No.93, Dashun 1st Rd., Zuoying Dist., Kaohsiung, Taiwan
TEL: 886-7-5577660 FAX: 886-7-5570560

MANUFACTURING SITE

- KAOHSIUNG FACTORY 1: No. 51, Kaifa Rd., N.E.P.Z, Kaohsiung City 81170, Taiwan
TEL: 886-7-9616668 FAX: 886-7-9616698
- KAOHSIUNG FACTORY 2: No. 2-2, Xinjian S. Rd., N.E.P.Z., Kaohsiung City 81170, Taiwan
TEL: 886-7-9630001 FAX: 886-7-3635113
- CHANGZHOU FACTORY: No.6 Longmen Rd., Wujin High & New-Tech Industrial
Development Zone, Changzhou, Jiangsu, China 213161
TEL: 86-519-86578999 FAX: 86-519-86558643
- DONG GUAN FACTORY: No.45, East Rd., Sha-Tao Dist., Chang-An Town,
Dongguan City, Guangdong, China 523863
TEL: 86-769-85542016 FAX: 86-769-85546890
- YICHANG FACTORY: No. 283 Xiaoting Avenue, Xiaoting Dist., Yichang
City 443007, Hubei, China
TEL: 86-717-6510010 FAX: 86-717-6511430



SPECIFICATION FOR APPROVAL

CUSTOMER _____

CERTIFIED
MODEL/TYPE

TVR07221-D

PART NO.

TVR07221KSABW(RoHS)

APPLICATION _____

CUSTOMER P/N _____

ISSUE DATE

May.23.2018

REV. NO. _____

REV. DATE _____

| FOR CUSTOMER APPROVAL | CHECKED BY |
|-----------------------|----------------|
| | Yuan Yuan |
| | APPROVED BY |
| | Huaifang Zhang |





REVISED RECORD SHEET

| REV. NO | REV. DATE | REVISED CONTENT |
|---------|-----------|-----------------|
| | | |



| INDEX | Page |
|--|-------------|
| ■ Part Number Code | 1 |
| ■ Structure and Dimensions | 2 |
| ■ Electrical Characteristics | 2 |
| ■ Reliability | 3 ~ 4 |
| ■ Soldering Recommendation | 5 |
| ■ Power Derating Curve | 6 |
| ■ RoHS Compliant Declaration | 6 |
| ■ Warehouse Storage Conditions of Products | 6 |
| ■ Taping and Dimensions | 7 |
| ■ Packaging | 8 |
| ■ Safety Approvals | 9 |
| ■ Certificates | 9 |
| ■ Max. Surge Current Derating Curves | 10 |
| ■ Max. Leakage Current and Max. Clamping Voltage Curve | 11 |

Part Number Code

Example :

TVR **07** **221** **K** **S** **AB** **W**
 (1) (2) (3) (4) (5) (6) (7)

| No. | Item | Digit | Specification |
|-----|-------------------------------|-------|---|
| (1) | Product Type | TVR | Thinking varistor TVR type |
| (2) | Body Size | 07 | φ 07 mm |
| (3) | Varistor Voltage | 221 | $22 \times 10^1 \text{ V} = 220\text{V} (V_{1\text{mA}})$ |
| (4) | Tolerance of $V_{1\text{mA}}$ | K | ±10% |
| (5) | Appearance | S | Straight lead , epoxy coating |
| (6) | Packaging | A | Repositioning tapping(hole pitch: 12.7mm) |
| | | B | box |
| (7) | Optional Suffix | W | RoHS compliance&High surge series |

Structure and Dimensions

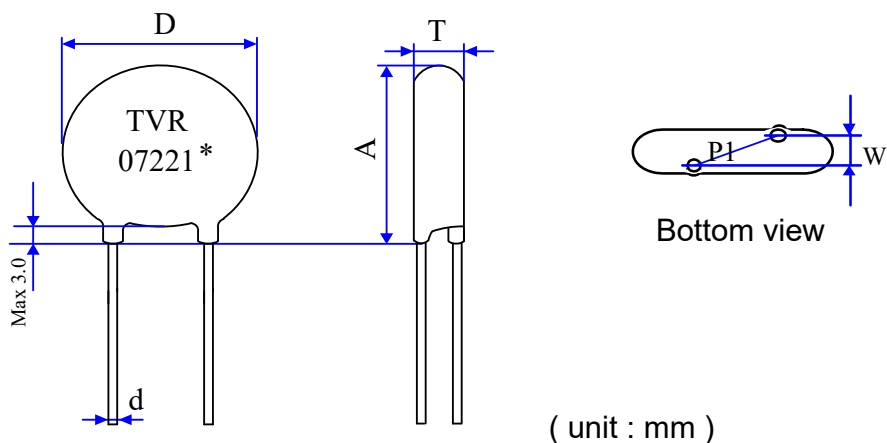

| Body Size | D | P 1 | d | A max. | T | W |
|-----------|---------|---------|----------|--------|---------|---------|
| φ 07D | 7.5~9.5 | 5.0±0.5 | 0.6±0.02 | 12.5 | 2.1~4.0 | 1.5±1.0 |

***Coating material rating:UL 94 V-0**

Electrical Characteristics (Ambient $T_a=25\text{ }^\circ\text{C}$)

| Part No. | Varistor Voltage (@ 1mA DC) | Max. Continuous Voltage | | Max. Clamping Voltage (8/20μS) | | Max. Surge Current (8/20μS) | Max. Energy (10/1000μS) |
|---------------|-----------------------------|-------------------------|--------------|--------------------------------|-----------|-----------------------------|-------------------------|
| | V_{1mA} (V) | $V_{AC}(rms)$ (V) | V_{DC} (V) | V_p (V) | I_p (A) | I (A) | W (J) |
| TVR07221KSABW | 220 ± 10 % | 140 | 180 | 360 | 10 | 1800 | 23 |

| Part No. | Rated Power | Impulse Response Time | Max. Leakage Current at 75% V_{1mA} | Operating Temperature | Storage Temperature |
|---------------|-------------|-----------------------|---------------------------------------|-----------------------|----------------------|
| | P (W) | nSec | $I_L(\mu A)$ | ($^\circ\text{C}$) | ($^\circ\text{C}$) |
| TVR07221KSABW | 0.25 | <25 | 20 | -40 ~ +85 | -40 ~ +125 |

Reliability

| Item | Standard | Test conditions / Methods | Specifications | | | | | | | | | | | | | | | |
|-------------------------------|------------------------|---|--|------------------|------------------|-----|------------|--------|--------|------------------|--|---|--------|--------|---|------------------|-------|--|
| Tensile Strength of Terminals | IEC60068-2-21 | Gradually applying the force specified and keeping the unit fixed for 10±1 sec. <table border="1" style="margin-left: auto; margin-right: auto;"> <tr> <td style="text-align: center;">Terminal diameter (mm)</td> <td style="text-align: center;">Force (Kg)</td> </tr> <tr> <td style="text-align: center;">0.5<d≤0.8</td> <td style="text-align: center;">1.0</td> </tr> <tr> <td style="text-align: center;">0.8<d≤1.25</td> <td style="text-align: center;">2.0</td> </tr> <tr> <td style="text-align: center;">1.25<d</td> <td style="text-align: center;">4.0</td> </tr> </table> | Terminal diameter (mm) | Force (Kg) | 0.5<d≤0.8 | 1.0 | 0.8<d≤1.25 | 2.0 | 1.25<d | 4.0 | No visible damage ΔV/V _{1mA} ≤5% | | | | | | | |
| Terminal diameter (mm) | Force (Kg) | | | | | | | | | | | | | | | | | |
| 0.5<d≤0.8 | 1.0 | | | | | | | | | | | | | | | | | |
| 0.8<d≤1.25 | 2.0 | | | | | | | | | | | | | | | | | |
| 1.25<d | 4.0 | | | | | | | | | | | | | | | | | |
| Bending Strength of Terminals | IEC60068-2-21 | Hold specimen and apply the force specified below to each lead. Bend the specimen to 90°, then return to the original position. Repeat the procedure in the opposite direction. <table border="1" style="margin-left: auto; margin-right: auto;"> <tr> <td style="text-align: center;">Terminal diameter (mm)</td> <td style="text-align: center;">Force (Kg)</td> </tr> <tr> <td style="text-align: center;">0.5<d≤0.8</td> <td style="text-align: center;">0.5</td> </tr> <tr> <td style="text-align: center;">0.8<d≤1.25</td> <td style="text-align: center;">1.0</td> </tr> <tr> <td style="text-align: center;">1.25<d</td> <td style="text-align: center;">2.0</td> </tr> </table> | Terminal diameter (mm) | Force (Kg) | 0.5<d≤0.8 | 0.5 | 0.8<d≤1.25 | 1.0 | 1.25<d | 2.0 | No visible damage ΔV/V _{1mA} ≤5% | | | | | | | |
| Terminal diameter (mm) | Force (Kg) | | | | | | | | | | | | | | | | | |
| 0.5<d≤0.8 | 0.5 | | | | | | | | | | | | | | | | | |
| 0.8<d≤1.25 | 1.0 | | | | | | | | | | | | | | | | | |
| 1.25<d | 2.0 | | | | | | | | | | | | | | | | | |
| Vibration | IEC 60068-2-6 | Frequency range:10~55Hz Amplitude:0.75mm or 98m/S ² Direction:3 mutually perpendicular directions,2hrs each. | ΔV/V _{1mA} ≤5% No visible damage | | | | | | | | | | | | | | | |
| Solderability | IEC60068-2-20 | 245 ± 3 °C , 3 ± 0.3 sec | At least 95% of terminal electrode is covered by new solder | | | | | | | | | | | | | | | |
| Resistance to Soldering Heat | IEC60068-2-20 | 260 ± 3 °C , 10 ± 1 sec | No visible damage ΔV/V _{1mA} ≤5% | | | | | | | | | | | | | | | |
| High Temperature Storage | IEC60068-2-2 | 125 ± 5 °C , 1000 ± 24 hrs | No visible damage ΔV/V _{1mA} ≤5% | | | | | | | | | | | | | | | |
| Damp Heat, Steady State | IEC 60068-2-78 | The test is divided into two groups . a.40 ± 2°C , 90 ~ 95 % RH , 1344 hrs b.40 ± 2°C , 90 ~ 95 % RH , at 10%V _{DC} , 1344 hrs | No visible damage ΔV/V _{1mA} ≤10% Insulation Resistance ≥ 100MΩ | | | | | | | | | | | | | | | |
| Rapid Change of Temperature | IEC60068-2-14 | The conditions shown below shall be repeated 5 cycles <table border="1" style="margin-left: auto; margin-right: auto;"> <thead> <tr> <th>Step</th> <th>Temperature (°C)</th> <th>Period (minutes)</th> </tr> </thead> <tbody> <tr> <td style="text-align: center;">1</td> <td style="text-align: center;">-40 ± 3</td> <td style="text-align: center;">30 ± 3</td> </tr> <tr> <td style="text-align: center;">2</td> <td style="text-align: center;">Room temperature</td> <td style="text-align: center;">5 ± 3</td> </tr> <tr> <td style="text-align: center;">3</td> <td style="text-align: center;">85 ± 2</td> <td style="text-align: center;">30 ± 3</td> </tr> <tr> <td style="text-align: center;">4</td> <td style="text-align: center;">Room temperature</td> <td style="text-align: center;">5 ± 3</td> </tr> </tbody> </table> | Step | Temperature (°C) | Period (minutes) | 1 | -40 ± 3 | 30 ± 3 | 2 | Room temperature | 5 ± 3 | 3 | 85 ± 2 | 30 ± 3 | 4 | Room temperature | 5 ± 3 | No visible damage ΔV/V _{1mA} ≤5% |
| Step | Temperature (°C) | Period (minutes) | | | | | | | | | | | | | | | | |
| 1 | -40 ± 3 | 30 ± 3 | | | | | | | | | | | | | | | | |
| 2 | Room temperature | 5 ± 3 | | | | | | | | | | | | | | | | |
| 3 | 85 ± 2 | 30 ± 3 | | | | | | | | | | | | | | | | |
| 4 | Room temperature | 5 ± 3 | | | | | | | | | | | | | | | | |
| High Temp. Load | MIL-STD-202 Method 108 | 85 ± 2 °C , 1000 ± 24 hrs, at V _{DC} or V _{rms} (Max. Operating Voltage) | ΔV/V _{1mA} ≤10% No visible damage | | | | | | | | | | | | | | | |



| Item | Standard | Test conditions / Methods | Specifications |
|---|---------------------------|--|---|
| 8/20 μ S Surge Life | IEC 61051-1 4.6 | 10,000 pulses(8/20 μ S) , unipolar, interval 10 secs, amplitude corr. to max. Surge current derating curves for 20 μ S | $ \Delta V/V_{1mA} \leq 10\%$ No visible damage |
| 10/1000 μ S Surge Life | IEC 61051-1 4.6 | 10/1000 μ S waveform, 10 surge currents,unipolar,interval 2mins, amplitude corr. to max. surge current derating curves for 1000 μ S | $ \Delta V/V_{1mA} \leq 10\%$ No visible damage |
| Varistor Voltage Temp. Coefficient | Specification Standard | $\frac{V_{1mA} \text{ at } 85^{\circ}\text{C} - V_{1mA} \text{ at } 25^{\circ}\text{C}}{V_{1mA} \text{ at } 25^{\circ}\text{C}} \times \frac{1}{60} \times 100 (\% / ^{\circ}\text{C})$ $\frac{V_{1mA} \text{ at } -40^{\circ}\text{C} - V_{1mA} \text{ at } 25^{\circ}\text{C}}{V_{1mA} \text{ at } 25^{\circ}\text{C}} \times \frac{1}{65} \times 100 (\% / ^{\circ}\text{C})$ | $-0.05 \leq TC \leq 0.05 (\% / ^{\circ}\text{C})$ |
| Voltage Proof | IEC 61051-1 4.9 | Metal balls method, 2500 Vac 1 min | No visible damage |

Soldering Recommendation

Wave Soldering Profile

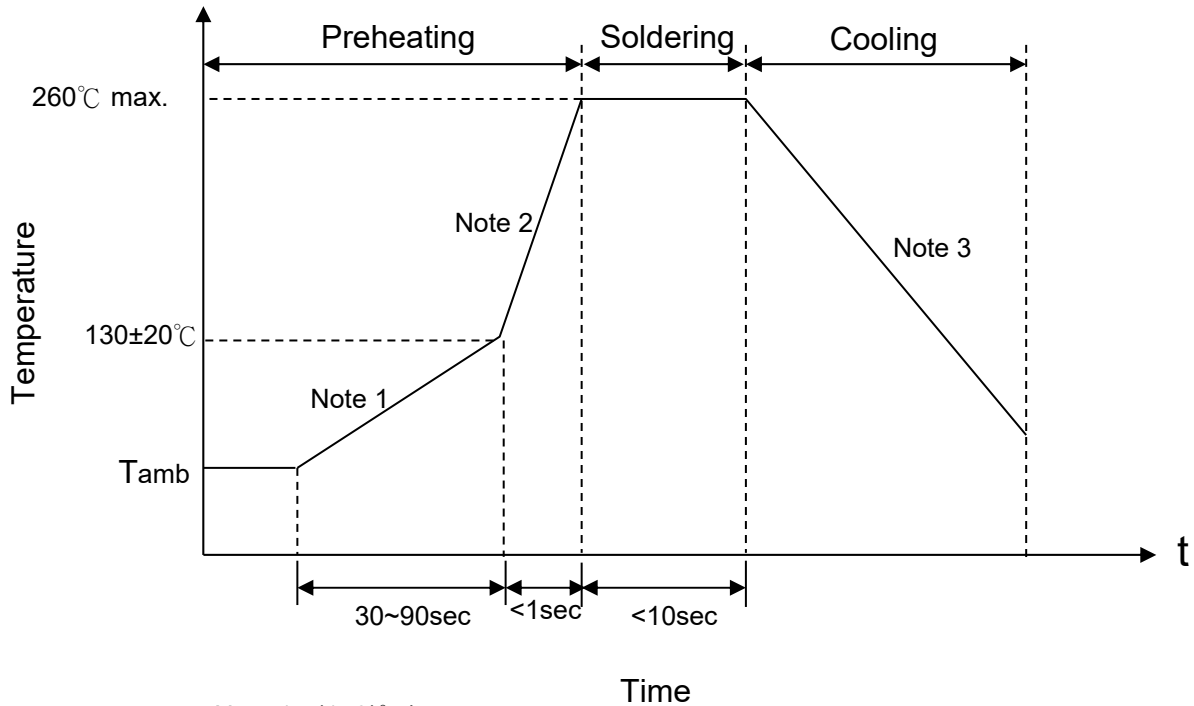

Note 1 : $(1\sim 3)^{\circ}\text{C}/\text{sec}$
 Note 2 : Approx. $200^{\circ}\text{C}/\text{sec}$
 Note 3 : $5^{\circ}\text{C}/\text{sec Max}$

Recommended Reworking Conditions with Soldering Iron

| Item | Conditions |
|-----------------------------------|------------------------------|
| Temperature of Soldering Iron-tip | 360°C (max.) |
| Soldering Time | 3 sec (max.) |
| Distance from Varistor | 2 mm (min.) |

Power Derating Curve

When operating temperature exceeds 85°C, the power, the Max.continuous operation Voltage, the Max.Surge Current and the Max.Energy should be derated as below figure, the derated coefficient is -2.5%.

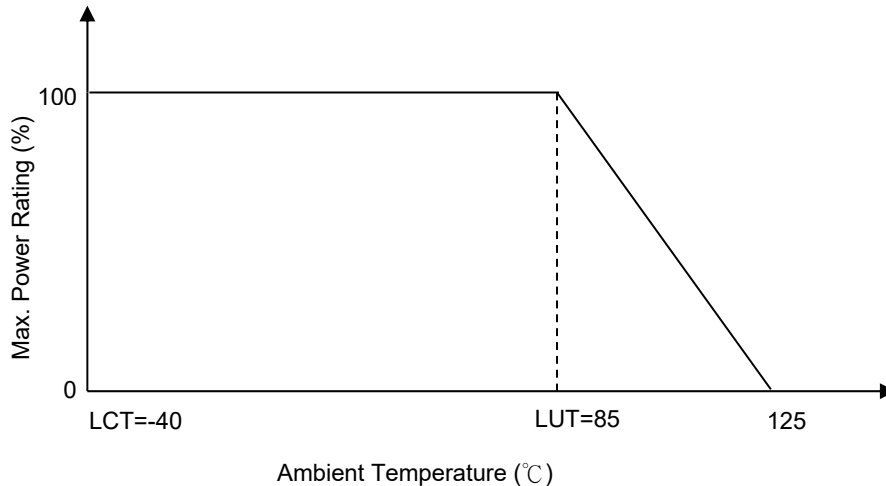

RoHS Compliant Declaration

We hereby declare that the components delivered to your company are compliant with RoHS directive 2011/65/EU.

Warehouse Storage Conditions of Products

(I) Storage Conditions :

- 1.Storage Temperature : -10°C~+40°C
- 2.Relative Humidity : $\leq 75\%RH$
- 3.Keep away from corrosive atmosphere and sunlight.

(II) Period of Storage : 1 year

Taping and Dimensions

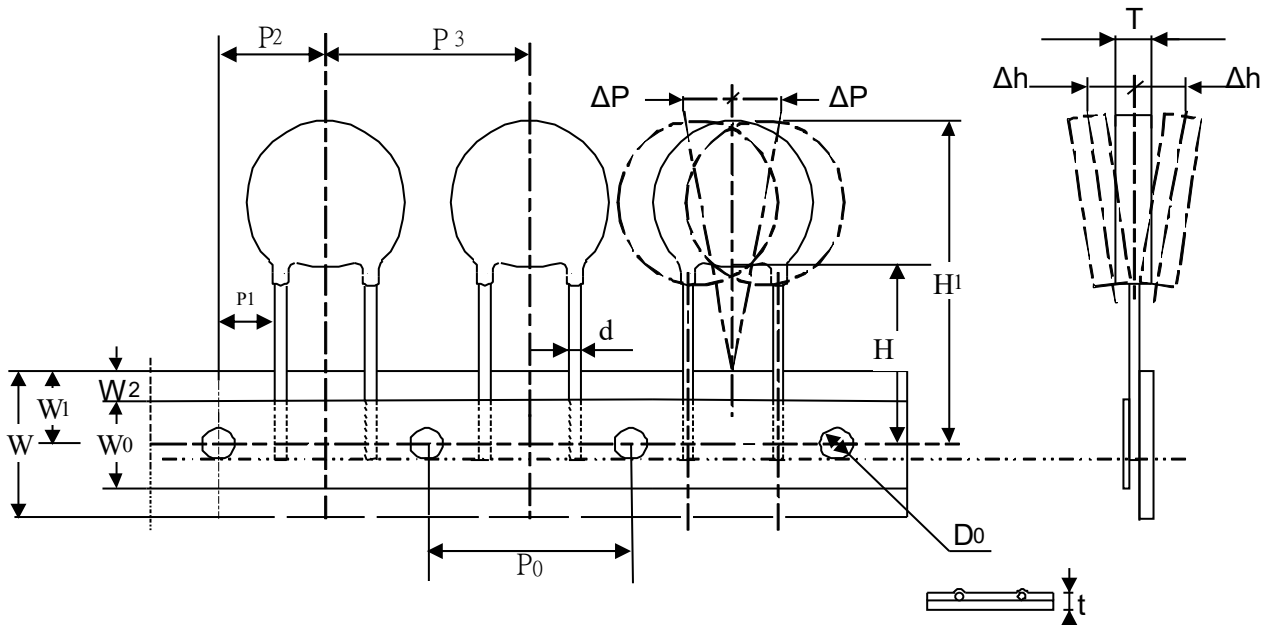

| ITEM. | P_0 | P_1 | P_2 | P_3 | H | H_1 Max | W_0 | W_1 | W_2 Max | W | Δp Max | Δh Max | D_0 | t |
|-------|-----------|---------|-----------|---------|---------|--------------|---------|--------------|--------------|---------|-------------------|-------------------|-----------|-----------|
| Nor. | 12.7 | 3.55 | 6.35 | 12.7 | 18 | 31 | 12 | 9 | 3 | 18 | 1.0 | 2.0 | 4 | 0.6 |
| ToL. | ± 0.3 | ± 1 | ± 1.3 | ± 1 | $+2/-0$ | --- | ± 1 | $+0.75/-0.5$ | --- | ± 1 | --- | --- | ± 0.2 | ± 0.2 |

(Unit:mm)

Packaging

(1) Inner Box (1200pcs /Box)

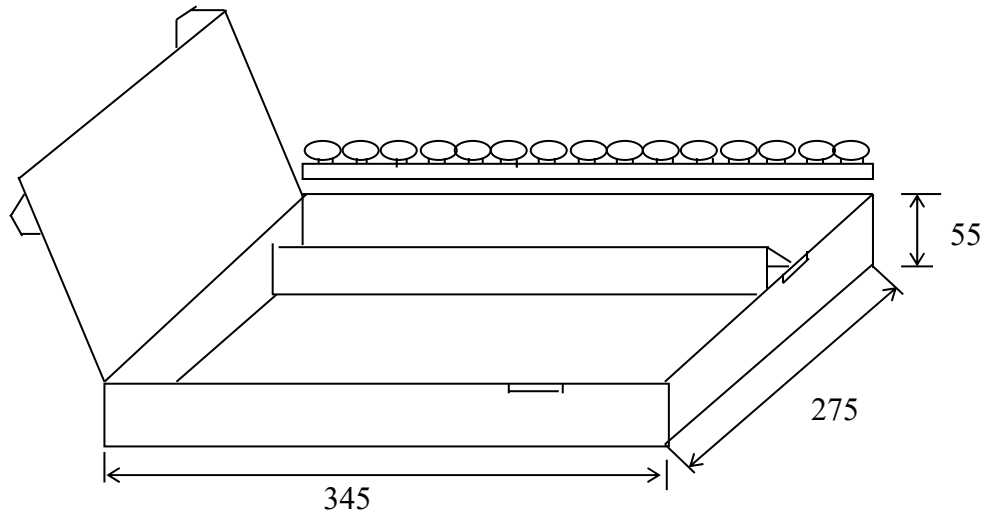

(2) Outer Box (5 Boxes /Carton)

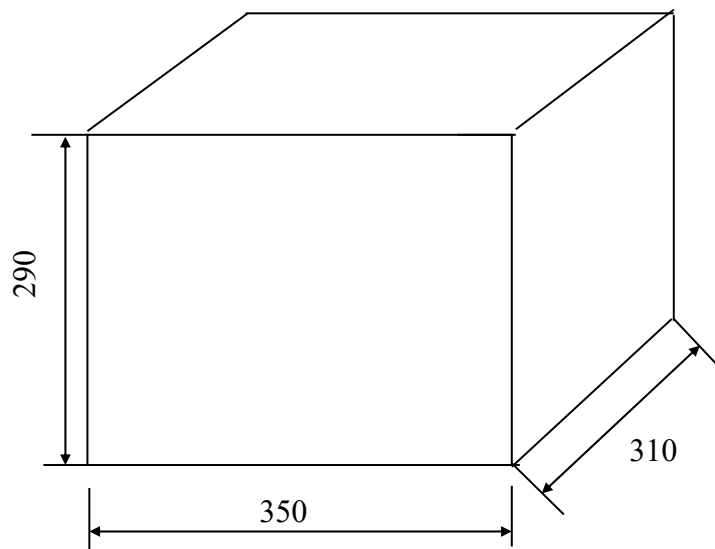

(Unit:mm)

Safety Approvals (Certified Model/Type :TVR07221-D)

* UL 1449 4th/ cUL recognized (File # E314979)



* VDE IEC 61051-1:2007-04 / IEC 61051-2:1991
IEC 61051-2-2:1991 recognized (File # 40021243)



* CQC GB/T10193-1997 ` GB/T10194-1997 recognized
(File # CQC10001041750/CQC10001041751)

Certificates

- (1) IATF 16949 certificate
- (2) ISO 9001 certificate

Test Report

- (1) RoHS test report

Max. Surge Current Derating Curves

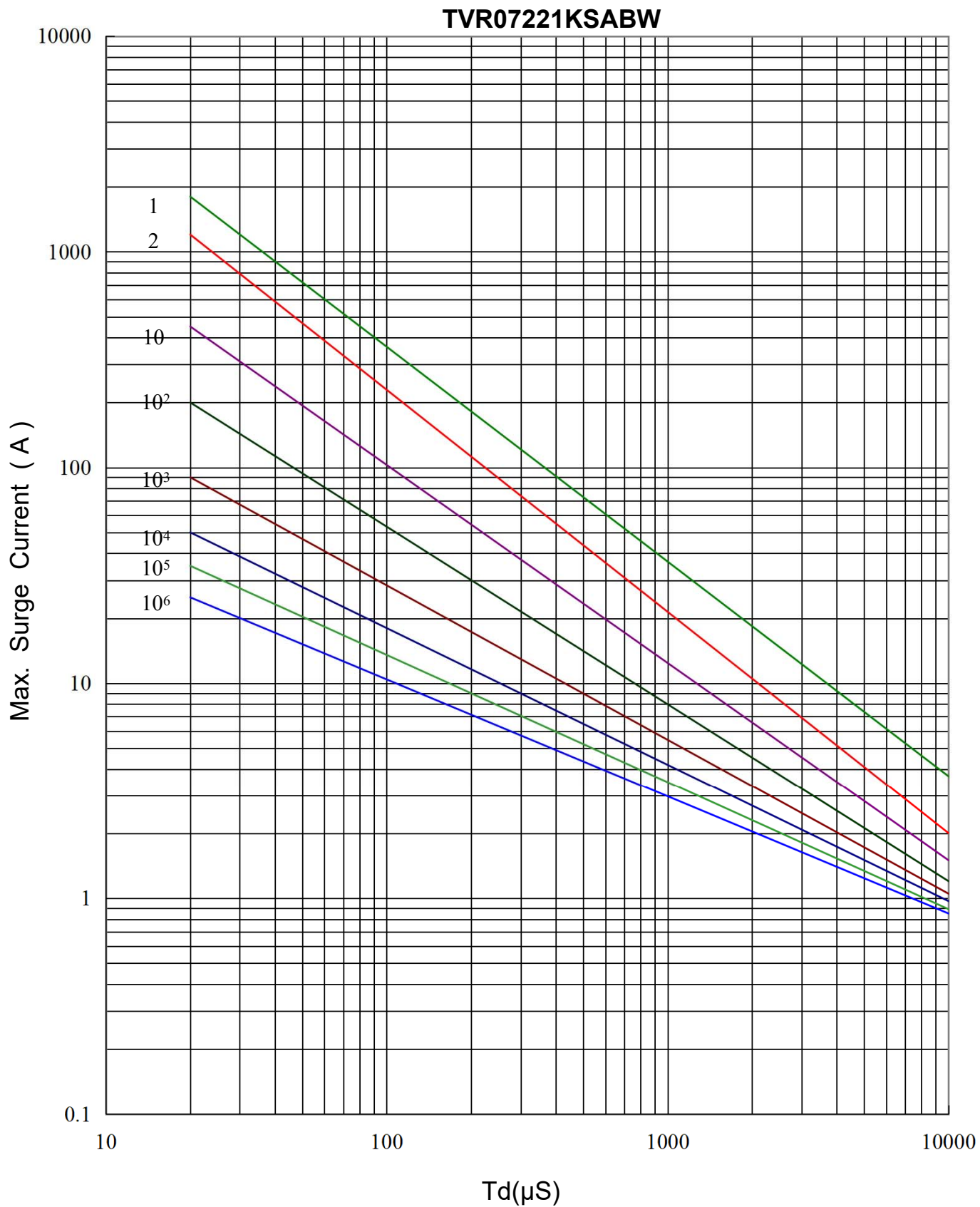

Max. Leakage Current and Max. Clamping Voltage Curve

TVR07221KSABW

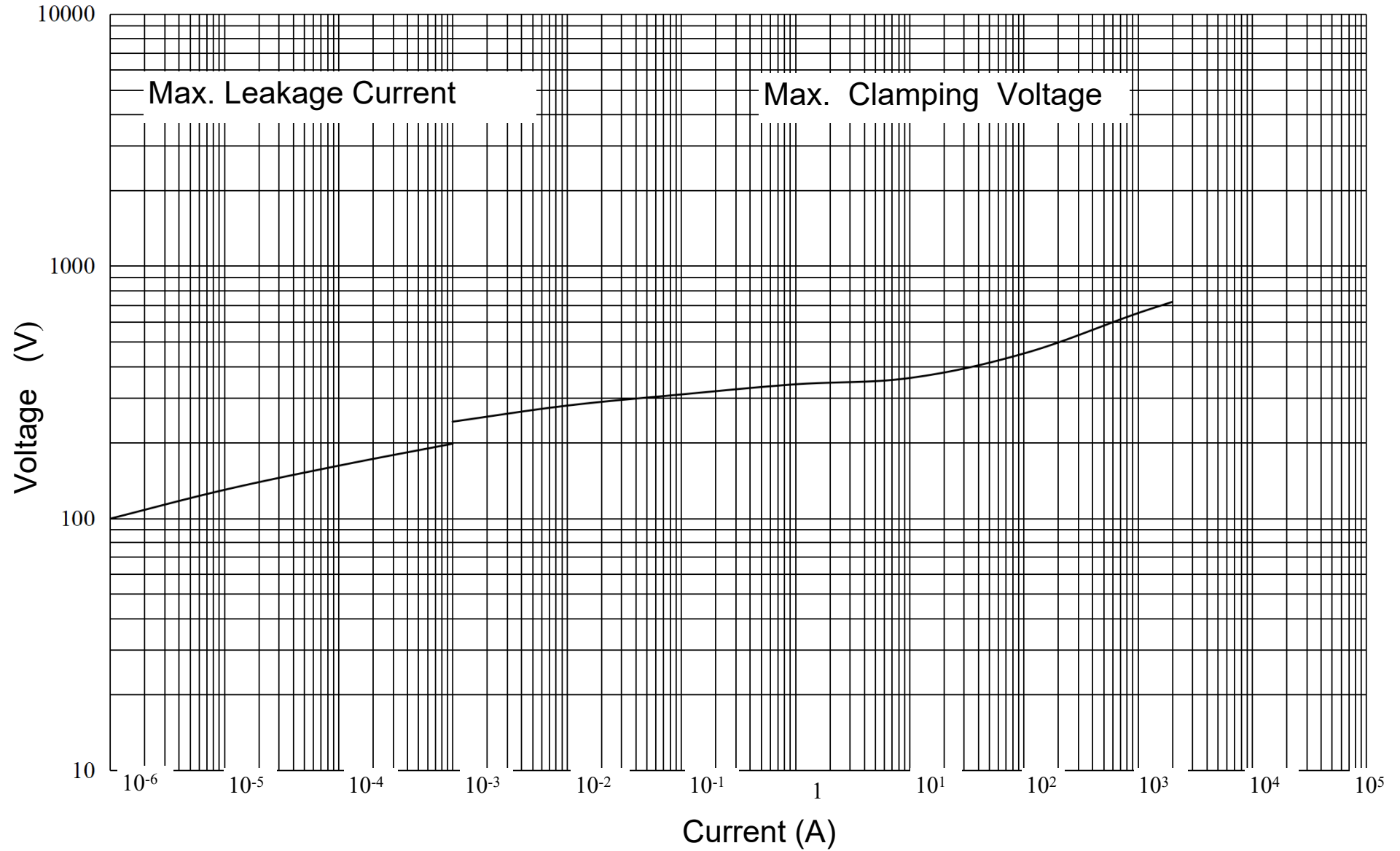

X-ON Electronics

Largest Supplier of Electrical and Electronic Components

Click to view similar products for [Varistors](#) category:

Click to view products by [TKS](#) manufacturer:

Other Similar products are found below :

[R71ZOV151HC](#) [B72205S271K111](#) [B72214S110K151](#) [B72214S251K151](#) [B72540E250K62](#) [NTE1V020](#) [NTE1V130](#) [25FN511K](#)
[S10K11G5S5](#) [ERZ-C14DK361U](#) [ERZ-C20DK221U](#) [ERZ-C32CK201B](#) [207869-1](#) [AS-13](#) [B72214S200K551](#) [B72280B112K1](#) [B72540E](#)
[350K 62](#) [B72590D360A60](#) [B72650M301K93](#) [B72670M1140K72](#) [TVZ18EC271KBS](#) [TVZ20EB911KBS](#) [TVZ25D201KBS](#) [TVZ25D241KBS](#)
[VDRH20X230BSE](#) [VZ07D220KBS](#) [VZ40D241KQ-N](#) [VZ40D241K](#) [VZ25D511KBS-N](#) [VZ20E511KBSX](#) [VZ20E221KBSX](#)
[VZ10D471KBS-N](#) [ERZ-V20R221](#) [20A9FN241K](#) [B72205S350K211](#) [B72214S110K551](#) [B72510E140K62](#) [B72650M350K72](#)
[TVZ25DN271KBS](#) [TVZ25D301KBS](#) [TVZ20EC911KBS](#) [TVZ20EBN911KBS](#) [TVZ18EC471KBS](#) [B72220S350K101](#) [B72540E300K62](#)
[TND10V-271KB00AAA0](#) [NTE1V030](#) [NTE1V275](#) [NTE2V015](#) [NTE2V035](#)