



THINKING ELECTRONIC INDUSTRIAL CO., LTD.

HEAD OFFICE: 12F, No.93, Dashun 1st Rd., Zuoying Dist., Kaohsiung, Taiwan
TEL: 886-7-5577660 FAX: 886-7-5570560

MANUFACTURING SITE

- KAOHSIUNG FACTORY 1: No. 51, Kaifa Rd., N.E.P.Z, Kaohsiung City 81170, Taiwan
TEL: 886-7-9616668 FAX: 886-7-9616698
- KAOHSIUNG FACTORY 2: No. 2-2, Xinjian S. Rd., N.E.P.Z., Kaohsiung City 81170, Taiwan
TEL: 886-7-9630001 FAX: 886-7-3635113
- CHANGZHOU FACTORY: No.6 Longmen Rd., Wujin High & New-Tech Industrial
Development Zone, Changzhou, Jiangsu, China 213161
TEL: 86-519-86578999 FAX: 86-519-86558643
- DONG GUAN FACTORY: No.45, East Rd., Sha-Tao Dist., Chang-An Town,
Dongguan City, Guangdong, China 523863
TEL: 86-769-85542016 FAX: 86-769-85546890
- YICHANG FACTORY: No. 283 Xiaoting Avenue, Xiaoting Dist., Yichang
City 443007, Hubei, China
TEL: 86-717-6510010 FAX: 86-717-6511430



SPECIFICATION FOR APPROVAL

CUSTOMER _____

CERTIFIED
MODEL/TYPE

TVR10561-M

PART NO.

TVR10561JL441M(RoHS+HF)

APPLICATION _____

CUSTOMER P/N _____

ISSUE DATE

Dec.25.2018

REV. NO. _____

REV. DATE _____

NET WEIGHT _____

FOR CUSTOMER APPROVAL	CHECKED BY
	Yuan Yuan
	APPROVED BY
	Huaifang Zhang





Zinc Oxide Varistor TVR Type
Part No. :TVR10561JL441M

REVISED RECORD SHEET

REV. NO	REV. DATE	REVISED CONTENT



INDEX	Page
■ Part Number Code	1
■ Structure and Dimensions	2
■ Electrical Characteristics	2
■ Reliability	3 ~ 4
■ Soldering Recommendation	5
■ Power Derating Curve	6
■ RoHS Compliant Declaration	6
■ Warehouse Storage Conditions of Products	6
■ Safety Approvals	7
■ Certificates	7
■ Max. Surge Current Derating Curves	8
■ Max. Leakage Current and Max. Clamping Voltage Curve	9

Part Number Code

Example :

TVR **10** **561** **J** **L** **441M**
 (1) (2) (3) (4) (5) (6)

No.	Item	Digit	Specification
(1)	Product Type	TVR	Thinking varistor TVR type
(2)	Body Size	10	φ10 mm
(3)	Varistor Voltage	561	Refer to "Optional Suffix"
(4)	Tolerance of V_{1mA}	J	Refer to "Optional Suffix"
(5)	Appearance	L	Straight lead, Silicon Coating
(6)	Optional Suffix	441M	1.RoHS+HF compliance 2.Amax:14mm,Dmax:12mm,Tmax:5.8mm, d:0.6+/-0.05mm 3.V1mA:532-589V

Structure and Dimensions

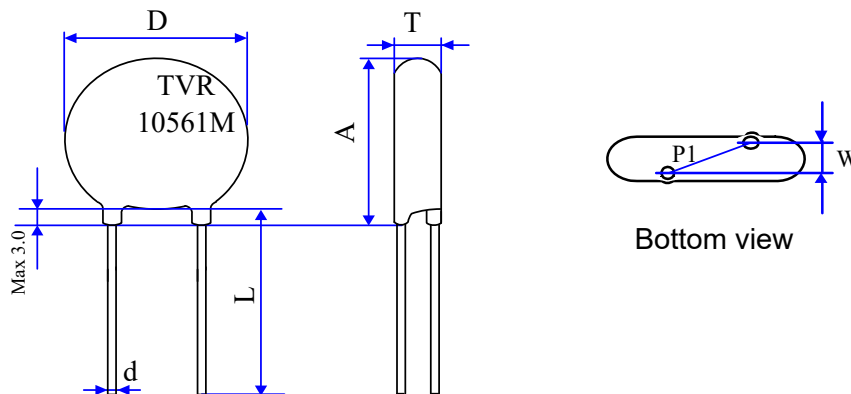

(unit : mm)

Body Size	Dmax	P 1	d	A max.	Lmin	T max	W
φ 10	12	7.5±0.5	0.60±0.05	14.0	26.5	5.8	2.8±1

***Coating material rating:UL 94 V-0**

Electrical Characteristics (Ambient $T_a=25\text{ }^\circ\text{C}$)

Part No.	Varistor Voltage (@ 1mA DC)	Max. Continuous Voltage	Max. Clamping Voltage (8/20μS)		Max. Surge Current (8/20μS)	Max. Energy (10/1000μS)
	V_{1mA} (V)	$V_{AC}(rms)$ (V)	V_p (V)	I_p (A)	I (A)	W (J)
TVR10561JL441M	532-589	350	930	25	3500	92

Part No.	Rated Power	Impulse Response Time	Max. Leakage Current at 75% V_{1mA}	Operating Temperature Range	Storage temperature Range	Applications		
	P (W)	nSec	$I_L(\mu A)$	($^\circ\text{C}$)	($^\circ\text{C}$)	UL 1449	IEC 62368-1	IEC 60065
TVR10561JL441M	0.4	<25	20	-40 ~ +125	-40 ~ +150	SPD Type 5	2014/G.8.2	Clause 14.12

The mechanical force acted on the wire lead may cause cracks and chips of the coating ,but which does not affect the performance of the component

Reliability

Item	Standard	Test conditions / Methods	Specifications															
Tensile Strength of Terminals	IEC60068-2-21	Gradually applying the force specified and keeping the unit fixed for 10±1 sec. Terminal diameter (mm) Force (Kg) ----- 0.5<d≤0.8 1.0 0.8<d≤1.25 2.0 1.25<d 4.0	No visible damage ΔV/V _{1mA} ≤5%															
Bending Strength of Terminals	IEC60068-2-21	Hold specimen and apply the force specified below to each lead. Bend the specimen to 90°, then return to the original position. Repeat the procedure in the opposite direction. Terminal diameter (mm) Force (Kg) ----- 0.5<d≤0.8 0.5 0.8<d≤1.25 1.0 1.25<d 2.0	ΔV/V _{1mA} ≤5%															
Vibration	IEC 60068-2-6	Frequency range:10~55Hz Amplitude:0.75mm or 98m/S ² Direction:3 mutually perpendicular directions,2hrs each.	ΔV/V _{1mA} ≤5% No visible damage															
Solderability	IEC60068-2-20	245 ± 3 °C , 3 ± 0.3 sec	At least 95% of terminal electrode is covered by new solder															
Resistance to Soldering Heat	IEC60068-2-20	260 ± 5 °C , 10 ± 1 sec	No visible damage ΔV/V _{1mA} ≤5%															
High Temperature Storage	IEC60068-2-2	150 ± 5 °C , 1000 ± 24 hrs	No visible damage ΔV/V _{1mA} ≤5%															
Damp Heat, Steady State	IEC 60068-2-78	The test is divided into two groups . a.40 ± 2°C , 90 ~ 95 % RH , 1344 hrs b.40 ± 2°C , 90 ~ 95 % RH , at 10%V _{DC} , 1344 hrs	No visible damage ΔV/V _{1mA} ≤10% Insulation Resistance ≥ 100MΩ															
Rapid Change of Temperature	IEC60068-2-14	The conditions shown below shall be repeated 1000cycles <table border="1"> <thead> <tr> <th>Step</th> <th>Temperature (°C)</th> <th>Period (minutes)</th> </tr> </thead> <tbody> <tr> <td>1</td> <td>-40 ± 3</td> <td>30 ± 3</td> </tr> <tr> <td>2</td> <td>Room temperature</td> <td>5 ± 3</td> </tr> <tr> <td>3</td> <td>125 ± 2</td> <td>30 ± 3</td> </tr> <tr> <td>4</td> <td>Room temperature</td> <td>5 ± 3</td> </tr> </tbody> </table>	Step	Temperature (°C)	Period (minutes)	1	-40 ± 3	30 ± 3	2	Room temperature	5 ± 3	3	125 ± 2	30 ± 3	4	Room temperature	5 ± 3	No visible damage ΔV/V _{1mA} ≤5%
Step	Temperature (°C)	Period (minutes)																
1	-40 ± 3	30 ± 3																
2	Room temperature	5 ± 3																
3	125 ± 2	30 ± 3																
4	Room temperature	5 ± 3																
High Temp. Load	MIL-STD-202 Method 108	125 ± 2 °C , 1000 ± 24 hrs, at V _{rms} (Max. Operating Voltage)	ΔV/V _{1mA} ≤10% No visible damage															
Flammability test	Specification Standard	The varistor shall be subjected to 60sec.applications of test flame. Burner:Bunsen gas burner 9000kcal/m ³ Diameter of flame nozzle: Φ9.5mm Position : the specimen shall be fixed horizontal Point of application shall be approximately center of the specimen	No catching fire,and no flaming drops															



Item	Standard	Test conditions / Methods	Specifications
8/20 μ S Surge Life	IEC 61051-1 4.6	10,000 pulses(8/20 μ S) , unipolar, interval 10 secs, amplitude corr. to max. Surge current derating curves for 20 μ S	$ \Delta V/V_{1mA} \leq 10\%$ No visible damage
10/1000 μ S Surge Life	IEC 61051-1 4.6	10/1000 μ S waveform, 10 surge currents,unipolar,interval 2mins, amplitude corr. to max. surge current derating curves for 1000 μ S	$ \Delta V/V_{1mA} \leq 10\%$ No visible damage
Varistor Voltage Temp. Coefficient	Specification Standard	$\frac{V_{1mA} \text{ at } 125^{\circ}\text{C} - V_{1mA} \text{ at } 25^{\circ}\text{C}}{V_{1mA} \text{ at } 25^{\circ}\text{C}} \times \frac{1}{100} \times 100 (\% / ^{\circ}\text{C})$ $\frac{V_{1mA} \text{ at } -40^{\circ}\text{C} - V_{1mA} \text{ at } 25^{\circ}\text{C}}{V_{1mA} \text{ at } 25^{\circ}\text{C}} \times \frac{1}{65} \times 100 (\% / ^{\circ}\text{C})$	$-0.05 \leq TC \leq 0.05 (\% / ^{\circ}\text{C})$
Voltage Proof	IEC 61051-1 4.9	Metal balls method, 1000 Vac 1 min	No visible damage
Surge life test	Specification Standard	4KV/2KA,Coupled with265Vac,Interval 60S, +5times,-5times ,40times (at phase angle of 0 degree,90 degrees,180 degrees,and 270 degrees)	No visible damage

Soldering Recommendation

Wave Soldering Profile

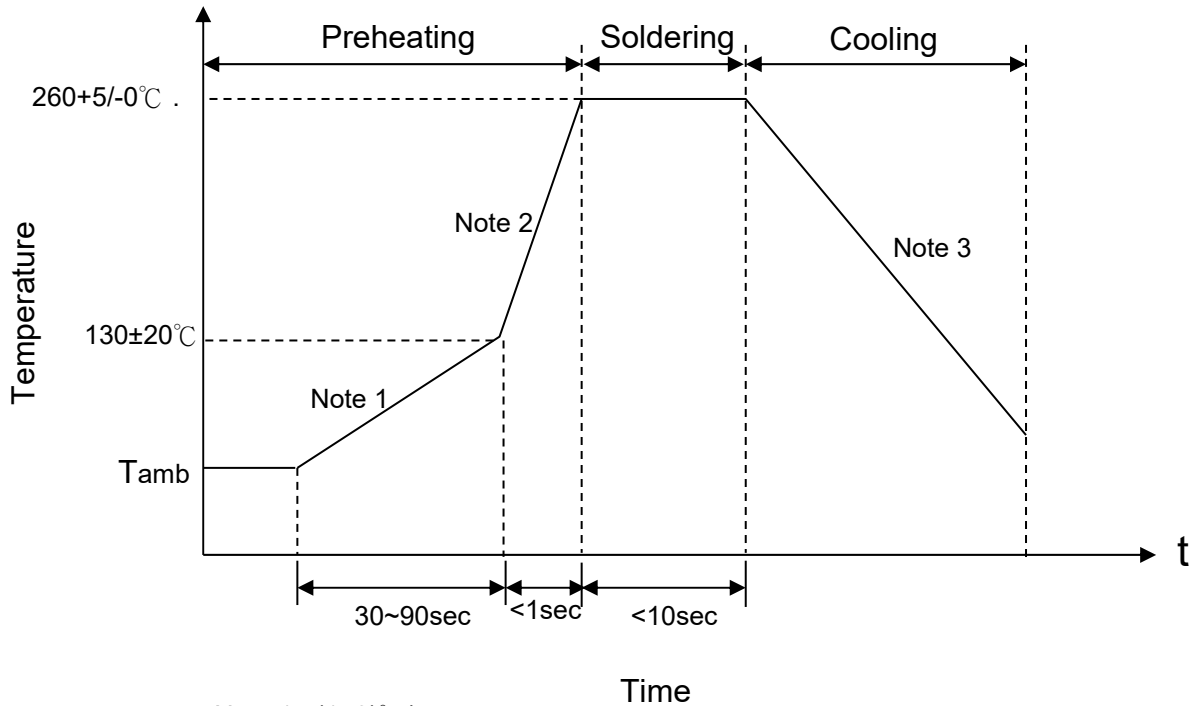

- Note 1 : $(1 \sim 3)^\circ\text{C}/\text{sec}$
 Note 2 : Approx. $200^\circ\text{C}/\text{sec}$
 Note 3 : $5^\circ\text{C}/\text{sec}$ Max

Recommended Reworking Conditions with Soldering Iron

Item	Conditions
Temperature of Soldering Iron-tip	$350^\circ\text{C} \sim 400^\circ\text{C}$
Soldering Time	3 sec (max.)
Distance from Varistor	2 mm (min.)

Power Derating Curve

When operating temperature exceeds 125°C , the power, the Max.continuous operation Voltage, the Max.Surge Current and the Max.Energy should be derated as below figure, the derated coefficient is -4%.

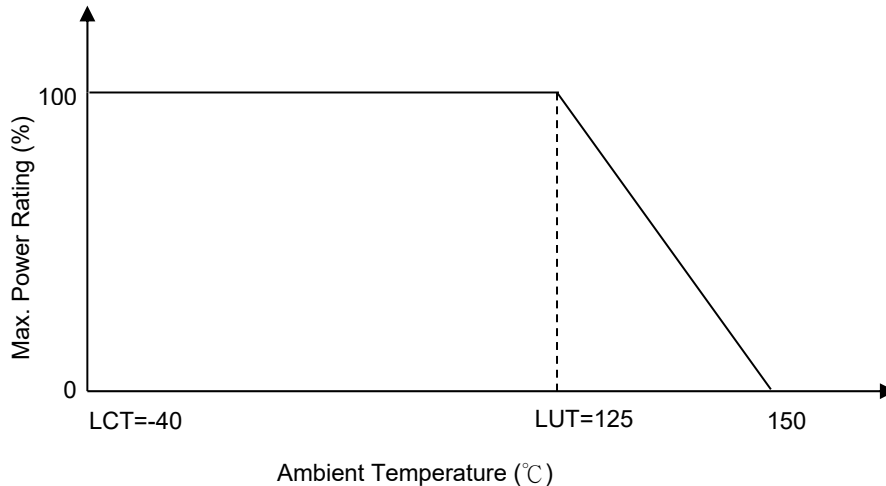

RoHS Compliant Declaration

We hereby declare that the components delivered to your company are compliant with RoHS directive 2011/65/EU.

Warehouse Storage Conditions of Products

(I) Storage Conditions :

- 1.Storage Temperature : $-10^{\circ}\text{C}\sim+40^{\circ}\text{C}$
- 2.Relative Humidity : $\leq 75\%RH$
- 3.Keep away from corrosive atmosphere and sunlight.

(II) Period of Storage : 1 year

Safety Approvals (Certified Model/Type:TVR10561-M)

- * UL 1449 4th / cUL recognized (File # E314979)
- UL1449 (file number E314979) for use in SPD Type 5



- *VDE IEC 61051-1:2007/IEC 61051-2:1991/ IEC 61051-2-2:1991
- DIN EN 61051-1:2009/IEC 61051-2 AMD1:2009
- IEC 62368-1:2014/G.8.2 recognized(File # 40036061)



- * CQC GB/T10193-1997 ` GB/T10194-1997 recognized
- (File # CQC13001090357/CQC13001090356)

Certificates

- (1) IATF 16949 certificate
- (2) ISO 9001 certificate

Test Report

- (1) RoHS test report
- (2) Halogen-free test report



Max. Surge Current Derating Curves

TVR10561JL441M

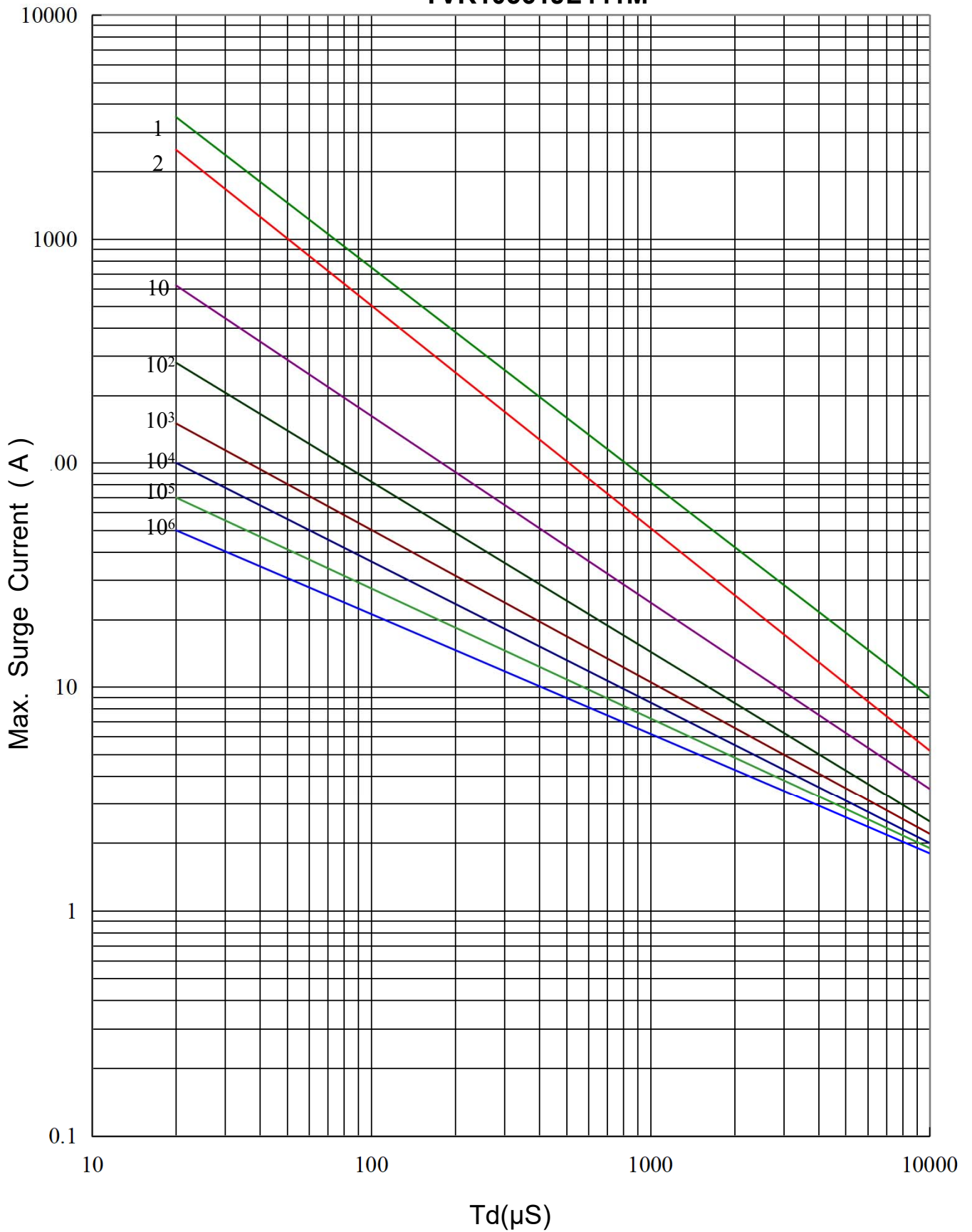



Max. Leakage Current and Max. Clamping Voltage Curve

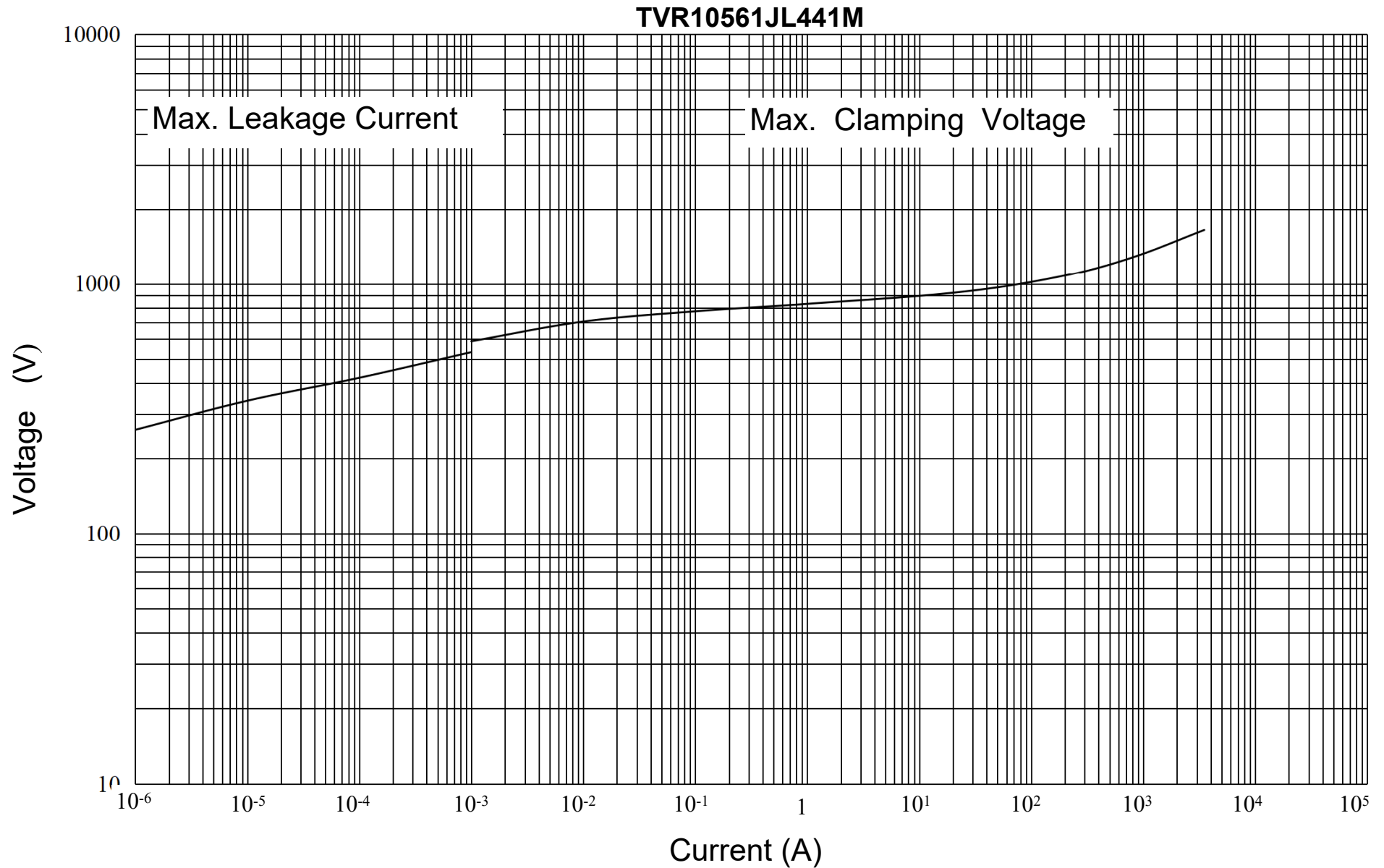

X-ON Electronics

Largest Supplier of Electrical and Electronic Components

Click to view similar products for [Varistors](#) category:

Click to view products by [TKS](#) manufacturer:

Other Similar products are found below :

[R71ZOV151HC](#) [B72205S271K111](#) [B72214S251K151](#) [NTE1V020](#) [NTE1V130](#) [25FN511K](#) [S10K11G5S5](#) [ERZ-C14DK361U](#) [ERZ-C20DK221U](#) [207869-1](#) [AS-13](#) [B72540E 350K 62](#) [B72590D360A60](#) [B72650M301K93](#) [B72670M1140K72](#) [TVZ18EC271KBS](#) [TVZ20EB911KBS](#) [TVZ25D201KBS](#) [TVZ25D241KBS](#) [VDRH20X230BSE](#) [VZ07D220KBS](#) [VZ40D241KQ-N](#) [VZ40D241K](#) [VZ25D511KBS-N](#) [VZ20E511KBSX](#) [VZ20E221KBSX](#) [VZ10D471KBS-N](#) [20A9FN241K](#) [B72650M350K72](#) [TVZ25D301KBS](#) [TVZ20EC911KBS](#) [TVZ20EBN911KBS](#) [TVZ18EC471KBS](#) [B72220S350K101](#) [NTE1V030](#) [NTE1V275](#) [NTE2V015](#) [NTE2V035](#) [NTE2V115](#) [VZ20D391KBS-N](#) [VZ10D241KBS-N](#) [VZ07D390KBS-N](#) [VDRH14V060TSE](#) [VDRH20X300BKE](#) [V300LT4PX1841](#) [NTE1V017](#) [NTE1V115](#) [NTE1V150](#) [NTE1V300](#) [NTE2V025](#)