



# THINKING ELECTRONIC INDUSTRIAL CO., LTD.

HEAD OFFICE: 8F-1, No.93, Ta-Shun 1st Rd., Kaohsiung, Taiwan

TEL: 886-7-5577660 FAX: 886-7-5570560

## MANUFACTURING SITE

- KAOHSIUNG FACTORY: No.51, Kaifa Road, Nantze Export Processing Zone, Kaohsiung City 81170, Taiwan  
TEL: 886-7-9616668 FAX: 886-7-9616698
- CHANGZHOU FACTORY: Wujin High & New Tech Ind. Development Zone, Hutang, Wujin, Changzhou City 213161, Jiangsu, China  
TEL: 86-519-86578999 FAX: 86-519-86558643
- DONG GUAN FACTORY: Chiao-Tou Tsun, Sha-Tao Hsiang, Chang-An Town, Dong-Guan City 523863, Guangdong, China  
TEL: 86-769-85542016 FAX: 86-769-85546890
- YICHANG FACTORY: No. 283 Xiaoting Avenue, Xiaoting Dist., Yichang City 443007, Hubei, China  
TEL: 86-717-6510010 FAX: 86-717-6511430



## SPECIFICATION FOR APPROVAL

CUSTOMER \_\_\_\_\_

CERTIFIED MODEL/TYPE

TVR14511

PART NO.

TVR14511KFRBF1F(RoHS+HF)

APPLICATION \_\_\_\_\_

CUSTOMER P/N \_\_\_\_\_

ISSUE DATE

Sep.13.2011

REV. NO \_\_\_\_\_

REV. DATE \_\_\_\_\_

FOR CUSTOMER APPROVAL	CHECKED BY
	Tiantian Liu
	APPROVED BY
	Huaifang Zhang





**REVISED RECORD SHEET**

REV. NO	REV. DATE	REVISED CONTENT



<b>INDEX</b>	<b>Page</b>
■ Part Number Code	1
■ Structure and Dimensions	2
■ Electrical Characteristics	2
■ Reliability	3 ~ 4
■ Soldering Recommendation	5
■ Power Derating Curve	6
■ RoHS Compliant Declaration	6
■ Storage Conditions of Products	6
■ Taping and Dimensions	7
■ Packaging	8
■ Safety Approvals	9
■ Certificates	9
■ Max. Surge Current Derating Curves	10
■ Max. Leakage Current and Max. Clamping Voltage Curve	11

Part Number Code

Example :

**TVR**    **14**    **511**    **K**    **F**    **RB**    **F1F**  
 (1)    (2)    (3)    (4)    (5)    (6)    (7)

No.	Item	Digit	Specification
(1)	Product Type	TVR	Thinking varistor TVR type
(2)	Body Size	14	φ 14 mm
(3)	Varistor Voltage	511	Refer to "Optional Suffix"
(4)	Tolerance of $V_{1mA}$	K	Refer to "Optional Suffix"
(5)	Appearance	F	Y Kink Lead, Epoxy Coating
(6)	Packaging	RB	Tape ( hole pitch: 12.7mm) & box
(7)	Optional Suffix	F1F	1. $V_{1mA}$ : 453~553V 2. Max. Operating Voltage( $V_{DC}$ ): 420V 3. Marking the production date code ( Such as: " ***" , " " is "year" code , "****" is "weeks" code) and UL CSA VDE on the body 4. RoHS+HF compliance

Structure and Dimensions

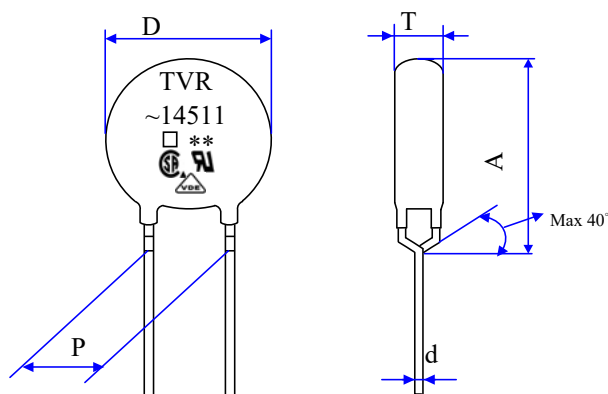

( unit : mm )

Body Size	D max.	P	d	A max.	T max.
φ 14	16.0	7.5±0.5	0.80±0.02	19.0	5.8

Electrical Characteristics ( Ambient  $T_a=25\text{ }^\circ\text{C}$  )

Part No.	Varistor Voltage (@ 1mA DC)	Max. Operating Voltage		Max. Clamping Voltage (8/20μS)		Max. Surge Current (8/20μS)	Max. Energy (10/1000μS)
	$V_{1mA}$ (V)	$V_{AC(rms)}$ (V)	$V_{DC}$ (V)	$V_p$ (V)	$I_p$ (A)	I (A)	W (J)
TVR14511KFRBF1F	453~553	320	420	845	50	4500	125

Part No.	Rated Power	Impulse Response Time	Max. Leakage Current at 75% $V_{1mA}$	*Reference Capacitance @1KHZ	Operating Temperature	Storage Temperature	Applications		
	P (W)	nSec	$I_L(\mu A)$	C (pF)	( $^\circ\text{C}$ )	( $^\circ\text{C}$ )	UL 1449	IEC 60950-1	IEC 60065
TVR14511KFRBF1F	0.6	<50	20	290	-40 ~ +85	-55 ~ +125	SPD Type 3	Annex Q	Clause 14.12

\*Capacitance values are not subject to outgoing inspection.

**Reliability**

Item	Standard	Test conditions / Methods	Specifications															
Tensile Strength of Terminals	IEC60068-2-21	Gradually applying the force specified and keeping the unit fixed for 10±1 sec.  <table style="margin-left: auto; margin-right: auto;"> <tr> <td style="text-align: center;">Terminal diameter (mm)</td> <td style="text-align: center;">Force (Kg)</td> </tr> <tr> <td style="text-align: center;">0.5&lt;d≤0.8</td> <td style="text-align: center;">1.0</td> </tr> <tr> <td style="text-align: center;">0.8&lt;d≤1.25</td> <td style="text-align: center;">2.0</td> </tr> <tr> <td style="text-align: center;">1.25&lt;d</td> <td style="text-align: center;">4.0</td> </tr> </table>	Terminal diameter (mm)	Force (Kg)	0.5<d≤0.8	1.0	0.8<d≤1.25	2.0	1.25<d	4.0	No visible damage $ \Delta V/V_{1mA}  \leq 5\%$							
Terminal diameter (mm)	Force (Kg)																	
0.5<d≤0.8	1.0																	
0.8<d≤1.25	2.0																	
1.25<d	4.0																	
Bending Strength of Terminals	IEC60068-2-21	Hold specimen and apply the force specified below to each lead. Bend the specimen to 90°, then return to the original position. Repeat the procedure in the opposite direction.  <table style="margin-left: auto; margin-right: auto;"> <tr> <td style="text-align: center;">Terminal diameter (mm)</td> <td style="text-align: center;">Force (Kg)</td> </tr> <tr> <td style="text-align: center;">0.5&lt;d≤0.8</td> <td style="text-align: center;">0.5</td> </tr> <tr> <td style="text-align: center;">0.8&lt;d≤1.25</td> <td style="text-align: center;">1.0</td> </tr> <tr> <td style="text-align: center;">1.25&lt;d</td> <td style="text-align: center;">2.0</td> </tr> </table>	Terminal diameter (mm)	Force (Kg)	0.5<d≤0.8	0.5	0.8<d≤1.25	1.0	1.25<d	2.0	No visible damage $ \Delta V/V_{1mA}  \leq 5\%$							
Terminal diameter (mm)	Force (Kg)																	
0.5<d≤0.8	0.5																	
0.8<d≤1.25	1.0																	
1.25<d	2.0																	
Vibration	IEC 1051-1	Frequency range:10~55Hz Amplitude:0.75mm or 98m/S <sup>2</sup> Direction:3 mutually perpendicular directions,2hrs each.	$ \Delta V/V_{1mA}  \leq 5\%$ No visible damage															
Solderability	IEC60068-2-20	245 ± 3 °C , 3 ± 0.3 sec	At least 95% of terminal electrode is covered by new solder															
Resistance to Soldering Heat	IEC60068-2-20	260 ± 3 °C , 10 ± 1 sec	No visible damage $ \Delta V/V_{1mA}  \leq 5\%$															
High Temperature Storage	IEC60068-2-2	125 ± 5 °C , 1000 ± 24 hrs	No visible damage $ \Delta V/V_{1mA}  \leq 5\%$															
Damp Heat, Steady State	IEC60068-2-3	The test is divided into two groups . a.40 ± 2°C , 90 ~ 95 % RH , 1344 hrs b.40 ± 2°C , 90 ~ 95 % RH , at 10%V <sub>DC</sub> , 1344 hrs	No visible damage $ \Delta V/V_{1mA}  \leq 10\%$ Insulation Resistance ≥ 100MΩ															
Rapid Change of Temperature	IEC60068-2-14	The conditions shown below shall be repeated 5 cycles  <table border="1" style="margin-left: auto; margin-right: auto;"> <thead> <tr> <th>Step</th> <th>Temperature (°C)</th> <th>Period (minutes)</th> </tr> </thead> <tbody> <tr> <td style="text-align: center;">1</td> <td style="text-align: center;">-40 ± 3</td> <td style="text-align: center;">30 ± 3</td> </tr> <tr> <td style="text-align: center;">2</td> <td style="text-align: center;">Room temperature</td> <td style="text-align: center;">5 ± 3</td> </tr> <tr> <td style="text-align: center;">3</td> <td style="text-align: center;">85 ± 2</td> <td style="text-align: center;">30 ± 3</td> </tr> <tr> <td style="text-align: center;">4</td> <td style="text-align: center;">Room temperature</td> <td style="text-align: center;">5 ± 3</td> </tr> </tbody> </table>	Step	Temperature (°C)	Period (minutes)	1	-40 ± 3	30 ± 3	2	Room temperature	5 ± 3	3	85 ± 2	30 ± 3	4	Room temperature	5 ± 3	No visible damage $ \Delta V/V_{1mA}  \leq 5\%$
Step	Temperature (°C)	Period (minutes)																
1	-40 ± 3	30 ± 3																
2	Room temperature	5 ± 3																
3	85 ± 2	30 ± 3																
4	Room temperature	5 ± 3																
Endurance at Upper Category Temperature	IEC61051-4.20	85 ± 2 °C , 1000 ± 24 hrs, at V <sub>DC</sub> or V <sub>rms</sub> (Max. Operating Voltage)	$ \Delta V/V_{1mA}  \leq 10\%$ No visible damage															

Item	Standard	Test conditions / Methods	Specifications
Low Temperature Storage (Optional)	CECC42000	-55 ± 5 °C, 1000 ± 24 hrs	$ \Delta V/V_{1mA}  \leq 5\%$ No visible damage
8/20μS Surge Life	CECC42000	10,000 pulses( 8/20 μ S ) , unipolar, interval 10 secs, amplitude corr. to max. Surge current derating curves for 20 μ S	$ \Delta V/V_{1mA}  \leq 10\%$ No visible damage
10/1000μS Surge Life	CECC42000	10/1000μS waveform, 10 surge currents,unipolar,interval 2mins, amplitude corr. to max. surge current derating curves for 1000μS	$ \Delta V/V_{1mA}  \leq 10\%$ No visible damage
Varistor Voltage Temp. Coefficient	Specification Standard	$\frac{V_{1mA} \text{ at } 85^{\circ}\text{C} - V_{1mA} \text{ at } 25^{\circ}\text{C}}{V_{1mA} \text{ at } 25^{\circ}\text{C}} \times \frac{1}{60} \times 100 (\% / ^{\circ}\text{C} )$ $\frac{V_{1mA} \text{ at } -40^{\circ}\text{C} - V_{1mA} \text{ at } 25^{\circ}\text{C}}{V_{1mA} \text{ at } 25^{\circ}\text{C}} \times \frac{-1}{65} \times 100 (\% / ^{\circ}\text{C} )$	-0.05 ≤ TC ≤ 0.05(%/°C)
Voltage Proof	IEC61051-4.8	Metal balls method, 2500 Vac 1 min	No visible damage

## Soldering Recommendation

### ■ Wave Soldering Profile

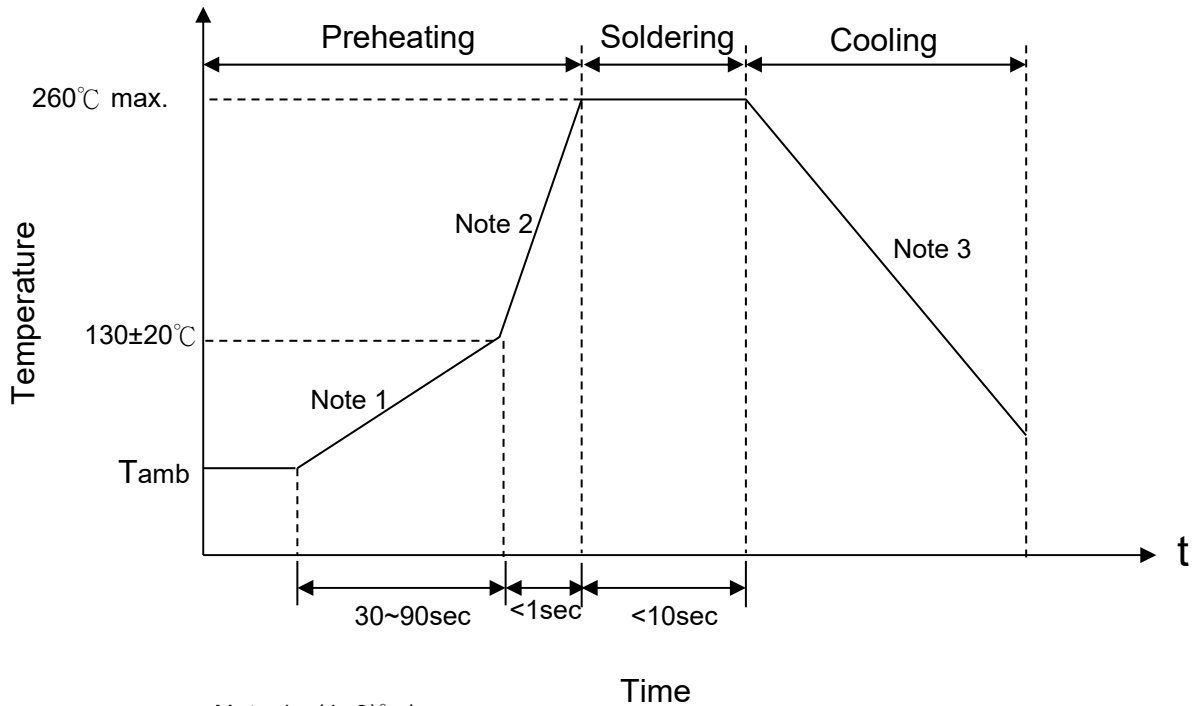

- Note 1 :  $(1\sim 3)^\circ\text{C/sec}$   
 Note 2 : Approx.  $200^\circ\text{C/sec}$   
 Note 3 :  $5^\circ\text{C/sec Max}$

### ■ Recommended Reworking Conditions with Soldering Iron

Item	Conditions
Temperature of Soldering Iron-tip	$360^\circ\text{C (max.)}$
Soldering Time	3 sec (max.)
Distance from Varistor	2 mm (min.)



## Power Derating Curve

When operating temperature exceeds 85°C, the power, the Max.continuous operation Voltage, the Max.Surge Current and the Max.Energy should be derated as below figure, the derated coefficient is -2.5%.

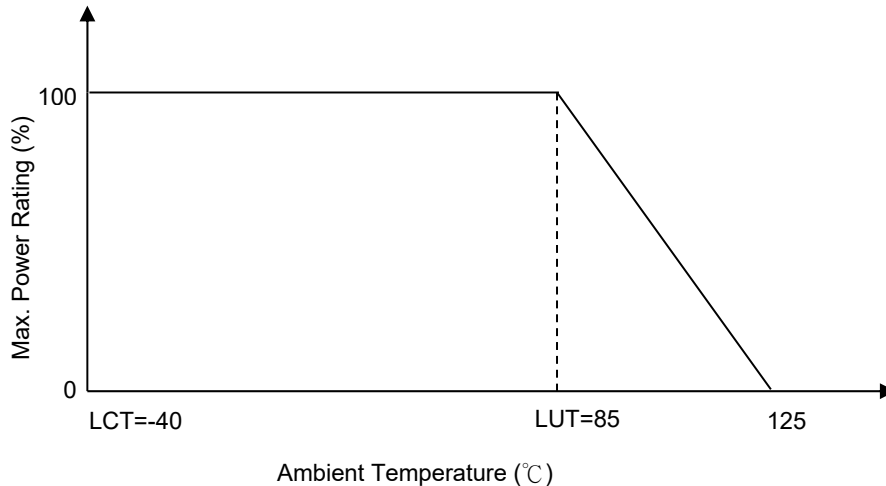

## RoHS Compliant Declaration

We hereby declare that the components delivered to your company are compliant with RoHS Directive 2002/95/EC

## Storage Conditions of Products

(I) Storage Conditions :

- 1.Storage Temperature : -10°C~+40°C
- 2.Relative Humidity :  $\leq 75\%RH$
- 3.Keep away from corrosive atmosphere and sunlight.

(II) Period of Storage : 1 year

Taping and Dimensions

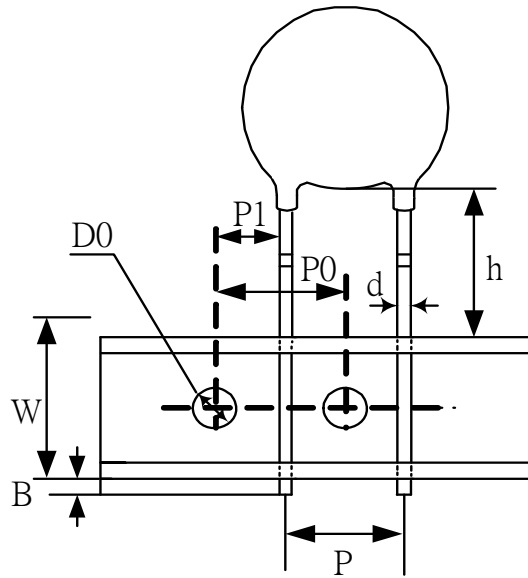

ITEM.	P	P0	P1	h	W	B	d	D0
Nor.	7.5	12.7	8.55	16.5	18	1	0.8	4
ToL.	±0.5	±1	±1	±1	±1	max	±0.02	±0.02

Packaging

(1) Inner Box (500pcs/box)

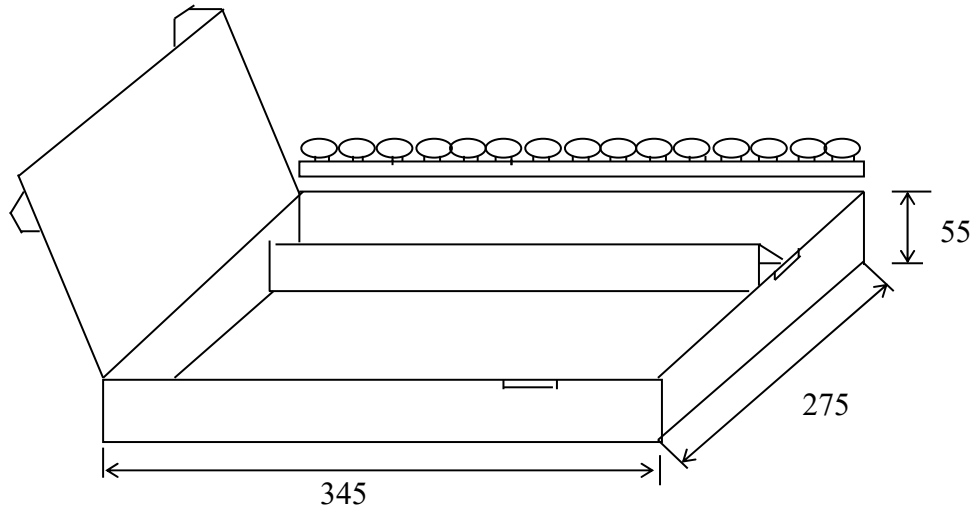

(2) Outer Box (5 Boxes /Carton)

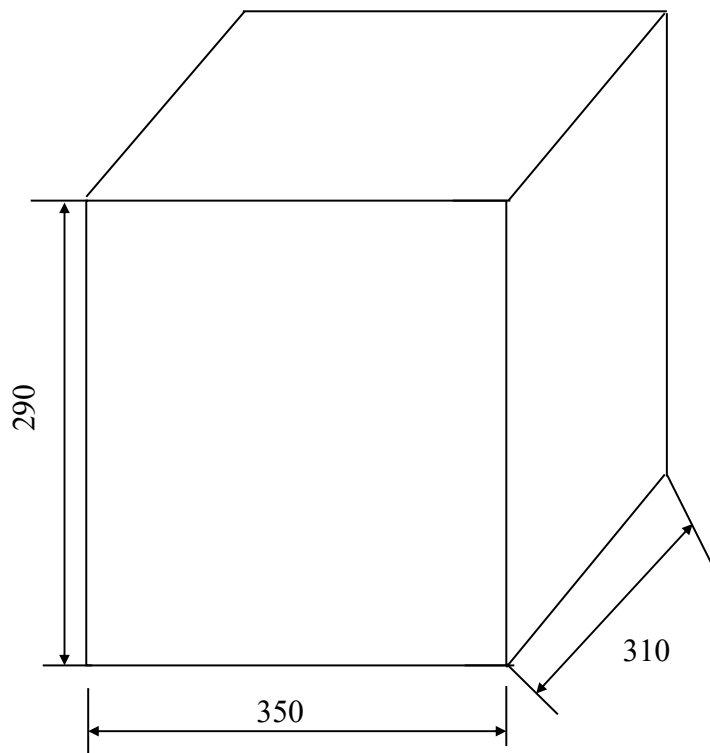

(Unit:mm)

Safety Approvals (Certified Model/Type :TVR14511)

- \* UL 1449 3rd / cUL recognized (File # E314979)
- \* UL 1414 / cUL recognized (File # E186499)
- UL1449 (file number E314979) for use in SPD Type 3
- Meet the surge requirements 6KV/3KA combination wave of IEC 60950-1 Annex Q and IEC 60065 14.12



- \* VDE IEC 61051-1:2007-04 / IEC 61051-2:1991  
IEC 61051-2-2:1991 recognized (File # 5944)



- \* CQC GB/T10193-1997 ` GB/T10194-1997 recognized  
(File # CQC03001005165/CQC03001007654)

Certificates

- (1) TS 16949 certificate
- (2) ISO 9001 certificate

Test Report

- (1) RoHS test report
- (2) Halogen-free test report

Max. Surge Current Derating Curves

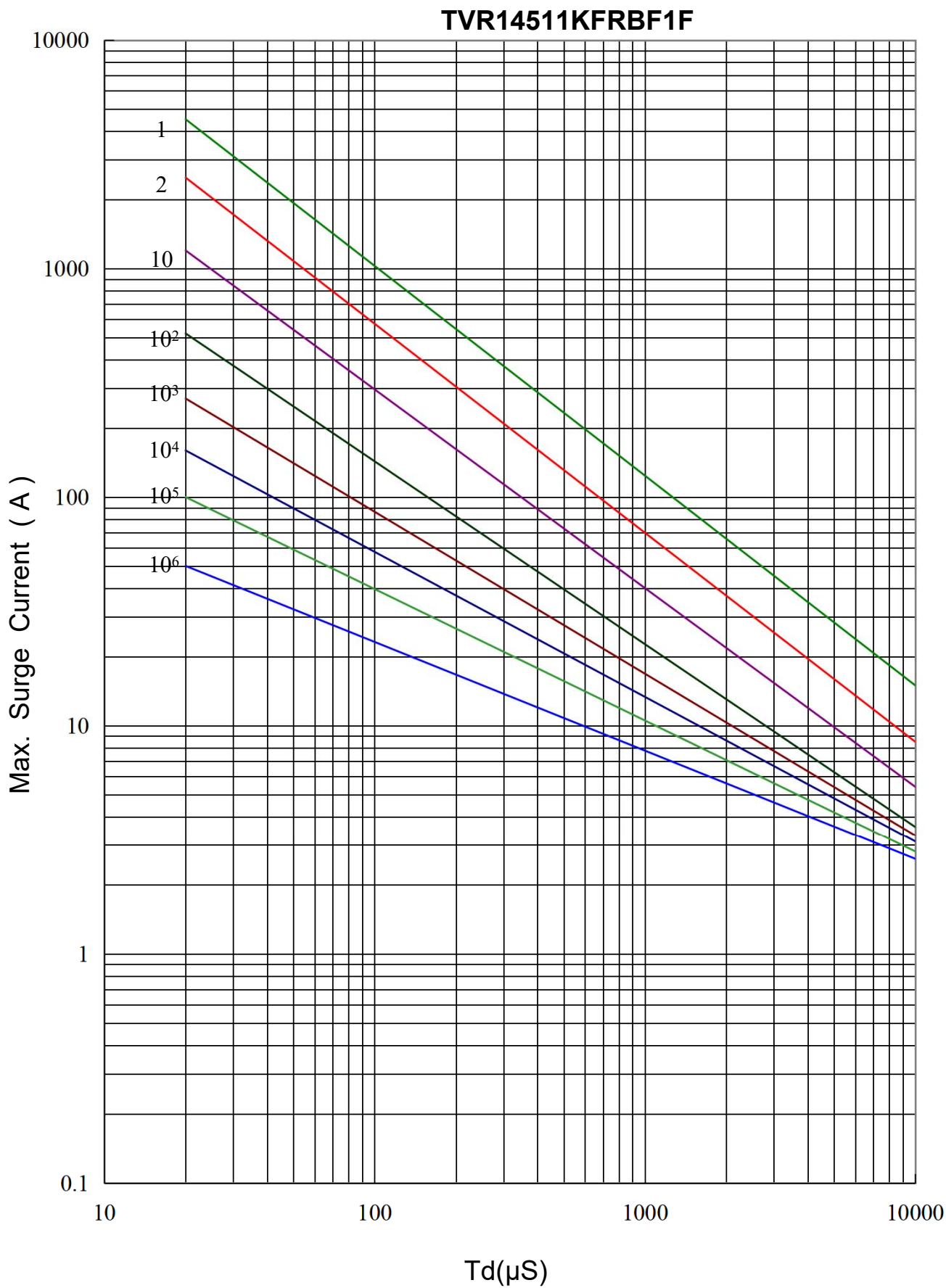



Max. Leakage Current and Max. Clamping Voltage Curve

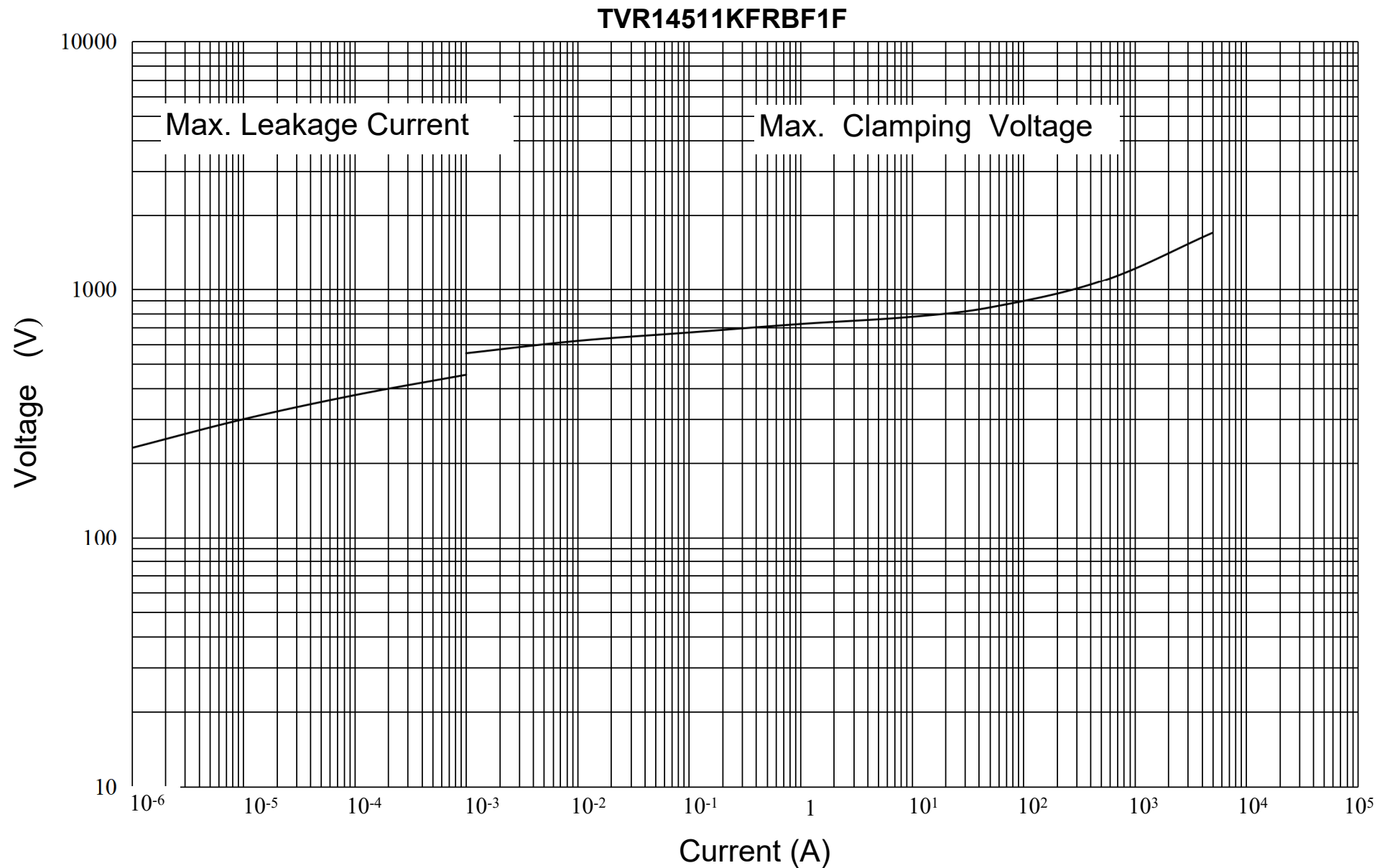

## X-ON Electronics

Largest Supplier of Electrical and Electronic Components

*Click to view similar products for [Varistors](#) category:*

*Click to view products by [TKS](#) manufacturer:*

Other Similar products are found below :

[R71ZOV151HC](#) [B72205S271K111](#) [B72214S110K151](#) [B72214S251K151](#) [B72540E250K62](#) [NTE1V020](#) [NTE1V130](#) [25FN511K](#)  
[S10K11G5S5](#) [ERZ-C14DK361U](#) [ERZ-C20DK221U](#) [ERZ-C32CK201B](#) [207869-1](#) [AS-13](#) [B72214S200K551](#) [B72280B112K1](#) [B72540E](#)  
[350K 62](#) [B72590D360A60](#) [B72650M301K93](#) [B72670M1140K72](#) [TVZ18EC271KBS](#) [TVZ20EB911KBS](#) [TVZ25D201KBS](#) [TVZ25D241KBS](#)  
[VDRH20X230BSE](#) [VZ07D220KBS](#) [VZ40D241KQ-N](#) [VZ40D241K](#) [VZ25D511KBS-N](#) [VZ20E511KBSX](#) [VZ20E221KBSX](#)  
[VZ10D471KBS-N](#) [ERZ-V20R221](#) [20A9FN241K](#) [B72205S350K211](#) [B72214S110K551](#) [B72510E140K62](#) [B72650M350K72](#)  
[TVZ25DN271KBS](#) [TVZ25D301KBS](#) [TVZ20EC911KBS](#) [TVZ20EBN911KBS](#) [TVZ18EC471KBS](#) [B72220S350K101](#) [B72540E300K62](#)  
[TND10V-271KB00AAA0](#) [NTE1V030](#) [NTE1V275](#) [NTE2V015](#) [NTE2V035](#)