

# 30V Output, 2.5A Current Limit, 1.2MHz High Efficiency Asynchronous Boost Regulator

## FEATURES

- 2.5V to 5.5V Input Voltage Range
- Integrated 100mΩ Power MOSFET
- 1.2MHz Fixed Switching Frequency
- Internal 2.5A Switch Current Limit Typically
- Adjustable Output Voltage with  
0.6V  $V_{FB}$  for STI3508C  
1.2V  $V_{FB}$  for STI3508CA
- Internal Compensation
- Up to 30V Output Voltage
- Automatic Pulse Frequency Modulation Mode at Light Loads
- Available in a 6-Pin SOT23-6 Package

## APPLICATIONS

- Portable Equipment Applications
- LED Application
- Digital Still and Video Cameras

## GENERAL DESCRIPTION

The STI3508C and STI3508CA are constant frequency, peak current mode step-up converter with SOT23-6 package intended for small, low power applications. The STI3508C and STI3508CA switch at 1.2MHz and allow the use of tiny, low cost capacitors and inductors 2mm or less in height. Internal soft-start results in small inrush current and extends battery life. The STI3508C and STI3508CA devices feature automatic shifting to pulse frequency modulation mode at light loads. The STI3508C and STI3508CA include under-voltage lockout, current limiting, and thermal overload protection to prevent damage in the event of an output overload. The STI3508C and STI3508CA are available in a small SOT23-6 package.

## TYPICAL APPLICATION

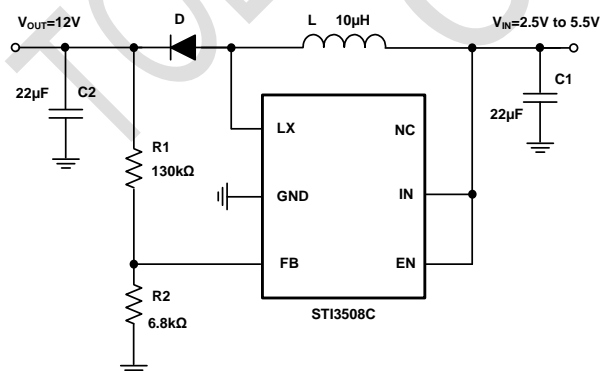
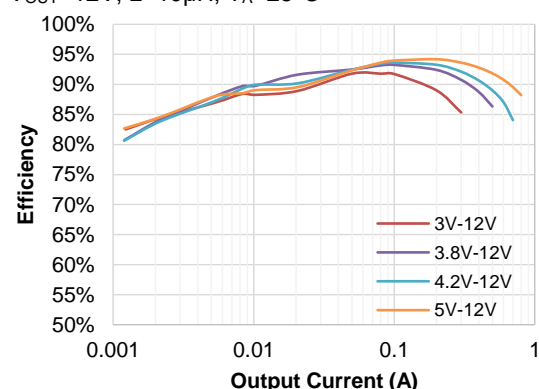

Figure 1. Basic Application Circuit of STI3508C

### Efficiency

$V_{OUT}=12V$ ,  $L=10\mu H$ ,  $T_A=25^\circ C$



**ABSOLUTE MAXIMUM RATINGS** (Note 1)

Parameter	Min	Max	Unit
Input Supply Voltages	-0.3	7	V
LX Voltages	-0.3	35	V
EN, FB Voltage	-0.3	7	V
Storage Temperature Range	-	150	°C
Junction Temperature (Note 2)	-40	150	°C
Power Dissipation	-	600	mW
Lead Temperature Soldering, 10Sec	-	260	°C

**PIN CONFIGURATION**

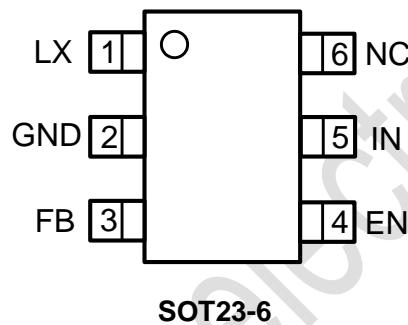

**Top Mark: S35Cxxx (S35C: Device Code, xxx: Inside Code) for STI3508C**  
**Top Mark: S35Dxxx (S35D: Device Code, xxx: Inside Code) for STI3508CA**

Part Number	Package	Top Mark	Quantity/ Reel
STI3508C	SOT23-6	S35Cxxx	3000
STI3508CA	SOT23-6	S35Dxxx	3000

STI3508C and STI3508CA devices are Pb-free and RoHS compliant.

## PIN FUNCTIONS

Pin	Name	Function
1	LX	Power Switch Output. LX is the drain of the internal MOSFET switch. Connect the power inductor and output rectifier to LX.
2	GND	Ground Pin
3	FB	Feedback Input. The FB voltage is 0.6V. Connect the resistor dividers to FB.
4	EN	Regulator On/Off Control Input. A high input at EN turns on the converter, and a low input turns it off. When not used, connect EN to the input supply for automatic startup.
5	IN	Input Supply Pin. Must be locally bypassed.
6	NC	No Connection.

## ESD RATING

Items	Description	Value	Unit
$V_{ESD\_HBM}$	Human Body Model for all pins	$\pm 2000$	V
$V_{ESD\_CDM}$	Charge Device Model for all pins	$\pm 1000$	V

JEDEC specification JS-001

## RECOMMENDED OPERATING CONDITIONS

Items	Description	Min	Max	Unit
Input Voltage Range	$V_{IN}$	2.5	5.5	V
Output Voltage Range	$V_{OUT}$	$V_{IN}$	30	V
$T_J$	Operating Junction Temperature Range	-40	125	$^{\circ}\text{C}$

## THERMAL RESISTANCE (Note 3)

Items	Description	Value	Unit
$\theta_{JA}$	Junction-to-ambient thermal resistance	200	$^{\circ}\text{C/W}$
$\theta_{JC}$	Junction-to-case thermal resistance	65	$^{\circ}\text{C/W}$

## ELECTRICAL CHARACTERISTICS

( $V_{IN}=V_{EN}=3.7V$ ,  $V_{OUT}=12V$ ,  $T_A = 25^{\circ}C$ , unless otherwise noted.)

Parameter	Test Conditions	Min	Typ	Max	Unit
Input Voltage Range		2.5		5.5	V
UVLO Threshold	$V_{IN}$ Rising		2.4	2.48	V
UVLO Hysteresis			200		mV
Quiescent Current	$V_{FB}=120\%*V_{REF}$ , No switch		30	100	$\mu A$
Standby Current	$V_{IN}=V_{EN}=3.7V$ , $I_{OUT}=0A$		450		$\mu A$
Shutdown Current	$V_{EN}=0V$		0.1	1	$\mu A$
Regulated Feedback Voltage	STI3508C, $T_A = 25^{\circ}C$	0.588	0.600	0.612	V
	STI3508CA, $T_A = 25^{\circ}C$	1.176	1.20	1.224	V
Oscillation Frequency	$V_{OUT}=100\%$	1.0	1.2	1.4	MHz
On Resistance of LX			100		m $\Omega$
Switching Current Limit			2.5		A
EN Input Low Level				0.3	V
EN Input High Level		1.5			V
EN Leakage Current			0.1	1.0	$\mu A$
LX Leakage Current	$V_{EN}=0V$ , $V_{IN}=V_{LX}=25V$		0.1	1.0	$\mu A$
Thermal Shutdown Threshold (Note 4)			160		$^{\circ}C$
Thermal Shutdown Hysteresis (Note 4)			25		$^{\circ}C$

**Note 1:** Absolute Maximum Ratings are those values beyond which the life of a device may be impaired.

**Note 2:**  $T_J$  is calculated from the ambient temperature  $T_A$  and power dissipation  $P_D$  according to the following formula:  $T_J = T_A + (P_D) \times \theta_{JA}$ .

**Note 3:** Measured on JESD51-7, 4-layer PCB.

**Note 4:** Guaranteed by design.

## FUNCTION DESCRIPTION

The STI3508C and STI3508CA,  $T_A = 25^\circ\text{C}$  uses a fixed frequency, peak current mode boost regulator architecture to regulate voltage at the feedback pin. The operation of the STI3508C and STI3508CA can be understood by referring to the block diagram of Figure 2. At the start of each oscillator cycle the MOSFET is turned on through the control circuitry. To prevent sub-harmonic oscillations at duty cycles greater than 50 percent, a stabilizing ramp is added to the output of the current sense amplifier and the result is fed into the negative input of the PWM comparator. When this voltage equals the output voltage of the error amplifier the power MOSFET is turned off. The voltage at the output of the error amplifier is an amplified version of the difference between the bandgap reference voltage and the feedback voltage. In this way the peak current level keeps the output in regulation. If the feedback voltage starts to drop, the output of the error amplifier increases. These results in more current to flow through the power MOSFET, thus increasing the power delivered to the output. The STI3508C and STI3508CA have internal soft start to limit the amount of input current at startup and to also limit the amount of overshoot on the output.

## FUNCTIONAL BLOCK DIAGRAM

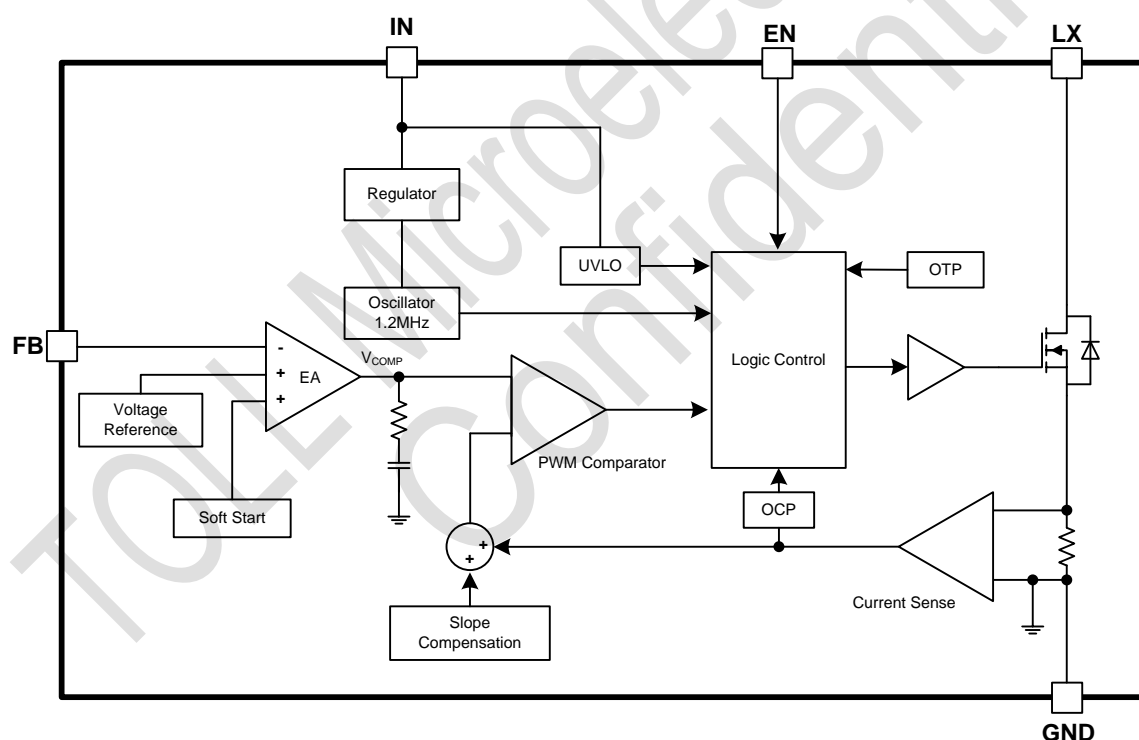

Figure 2. STI3508C and STI3508CA Block Diagram

## APPLICATION INFORMATION

### Setting the Output Voltage

The internal reference  $V_{REF}$  is 0.6V for STI3508C, and 1.2V of STI3508CA. The output voltage is divided by a resistor divider, R1 and R2 to the FB pin. The output voltage is given by

$$V_{OUT} = V_{REF} \times \left(1 + \frac{R_1}{R_2}\right)$$

### Inductor Selection

Inductor selection is important for ST3508C and STI3508CA applications. Inductor value determines input inductor current ripple value.

$$\Delta I_L = \frac{V_{IN} \times D}{f_s \times L} = \frac{V_{IN}}{f_s \times L} \times \left(1 - \frac{V_{IN} \times \eta}{V_{OUT}}\right)$$

Where:

D = duty cycle of boost converter

$\eta$  = efficiency of the converter, e.g. estimated 90%

The inductor current ripple determines maximum output current according to device switching current limit value.

$$I_{OUT\_max} = I_{L\_max} \times (1 - D) = \left(I_{SW\_LIM} - \frac{\Delta I_L}{2}\right) \times (1 - D)$$

Where:

$I_{SW\_LIM}$  = current limit of STI3508C, it is 2.5A typically.

Generally, the inductor current ripple is estimated 10% to 40% of the input inductor average current. The recommended value of inductor is 2.2 $\mu$ H to 10 $\mu$ H for most application. The inductor should have low core loss at 1.2MHz and low DCR for better efficiency. To avoid inductor saturation current rating should be considered according to the switching current limit of STI3508C and STI3508CA.

### Capacitor Selection

Input and output ceramic capacitors of 22 $\mu$ F are recommended for STI3508C and STI3508CA applications. As to output capacitor, the voltage rating is important for high voltage application and ceramic capacitor's derating under DC bias. Ceramic capacitors could reduce more than 50% its capacitance at its rated voltage. For better voltage filtering, ceramic capacitors with low ESR are recommended. X5R and X7R types are suitable because of their wider voltage and temperature ranges.

**Table 1: Recommended Selection for Common Output Voltages**

$V_{OUT}$ (V)	R1 (k $\Omega$ )	R2 (k $\Omega$ )	R2 (k $\Omega$ )	$C_{OUT}$ ( $\mu$ F)	L ( $\mu$ H)
		STI3508C	STI3508CA		
5	110	15	34.8	22	2.2 - 6.8
9	130	9.31	20.5	22	4.7 - 10
12	130	6.8	14.3	22	10
24	200	5.11	10.5	22	10

## Diode Selection

Schottky diode is a good choice for STI3508C and STI3508CA because of its low forward voltage drop and fast reverses recovery. Using Schottky diode can get better efficiency. The high-speed rectification is also a good characteristic of Schottky diode for high switching frequency. Current rating of the diode must meet the root mean square of the peak current and output average current multiplication as following:

$$I_D(\text{RMS}) \approx \sqrt{I_{\text{OUT}} \times I_{\text{PEAK}}}$$

The diode's reverse breakdown voltage should be larger than the output voltage.

## Layout Consideration

For best performance of the STI3508C and STI3508CA, the following guidelines must be strictly followed:

1. Input and Output capacitors should be placed close to the IC and connected to ground plane to reduce noise coupling. Input Capacitor should be placed close to IN pin and GND. Output capacitor must be placed close to diode output node and GND to reduce switching loop.
2. Keep the main current traces as possible as short and wide.
3. LX node of DC-DC converter is with high frequency voltage swing. It should be kept at a small area.
4. Place the feedback divider resistor R1 and R2 as close as possible to the IC FB pin and keep away from the noisy devices since FB is a high impedance input pin that is sensitive to noise.

TYPICAL PERFORMANCE CHARACTERISTICS

Efficiency at  $V_{OUT} = 5V$

$V_{OUT}=5V, L=4.7\mu H, T_A=25^\circ C$

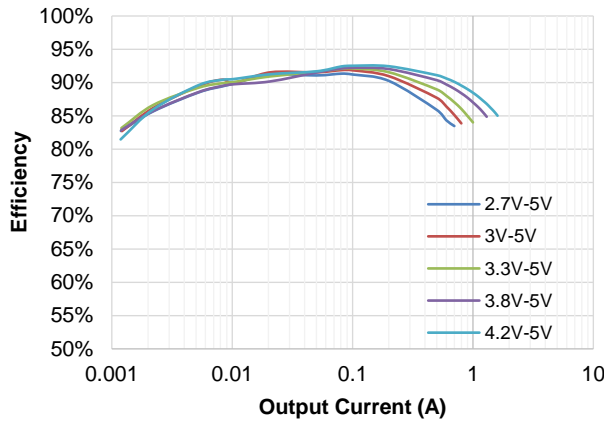

Efficiency at  $V_{OUT} = 9V$

$V_{OUT}=9V, L=6.8\mu H, T_A=25^\circ C$

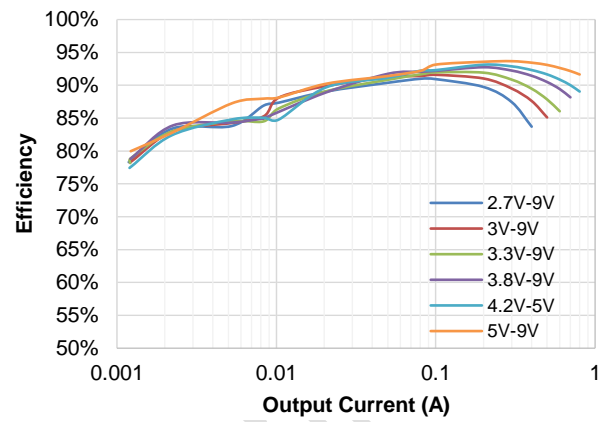

Efficiency at  $V_{OUT} = 12V$

$V_{OUT}=12V, L=10\mu H, T_A=25^\circ C$

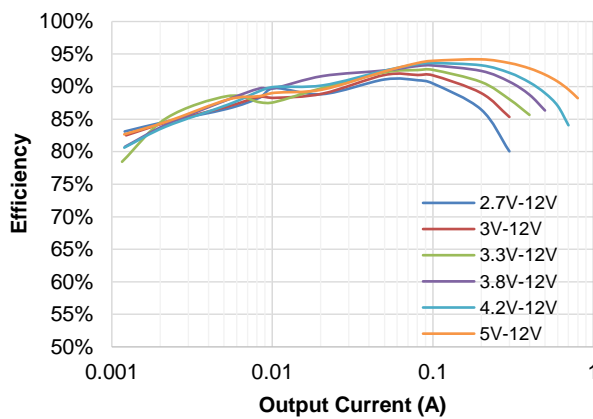

Efficiency at  $V_{OUT} = 24V$

$V_{OUT}=24V, L=10\mu H, T_A=25^\circ C$

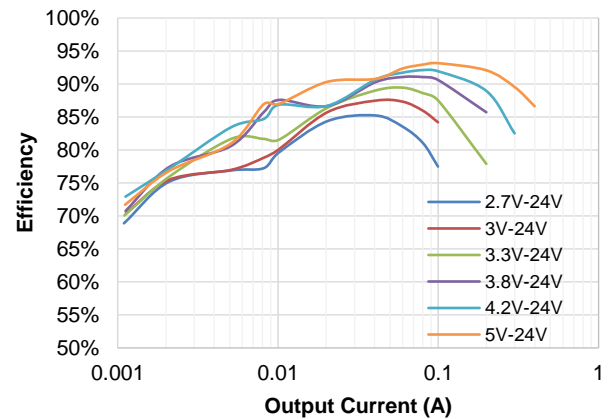

Load Regulation

$V_{OUT}=12V, L=10\mu H, T_A=25^\circ C$

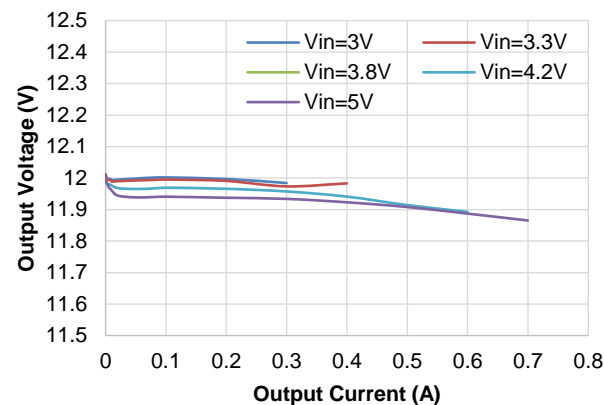

Line Regulation at  $V_{OUT} = 12V$

$V_{OUT}=12V, L=10\mu H, T_A=25^\circ C$

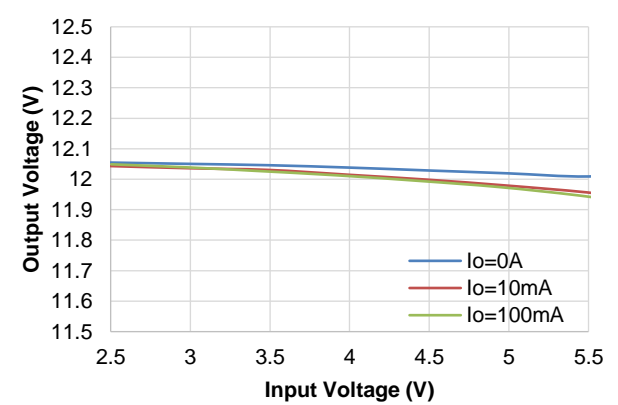



**TYPICAL PERFORMANCE CHARACTERISTICS** (continued)

**Steady State**

$V_{in}=5V, V_{out}=12V, I_{out}=0A, T_A=25^{\circ}C$

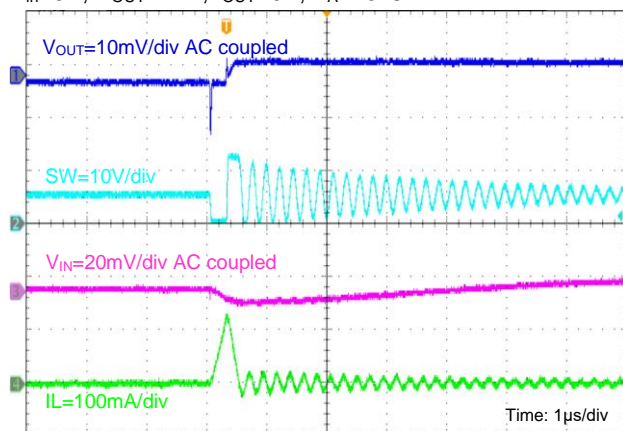

**Steady State**

$V_{in}=5V, V_{out}=12V, I_{out}=0.6A, T_A=25^{\circ}C$

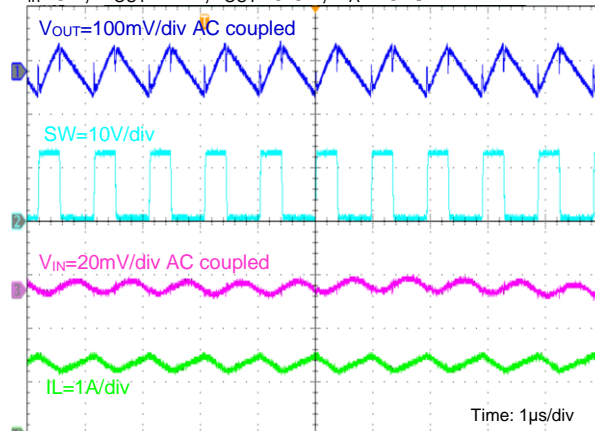

**VIN Power On**

$V_{in}=5V, V_{out}=12V, \text{No load}$

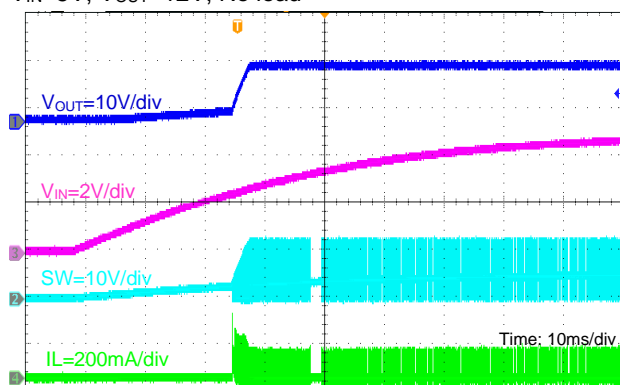

**VIN Power Off**

$V_{in}=5V, V_{out}=12V, \text{No Load}$

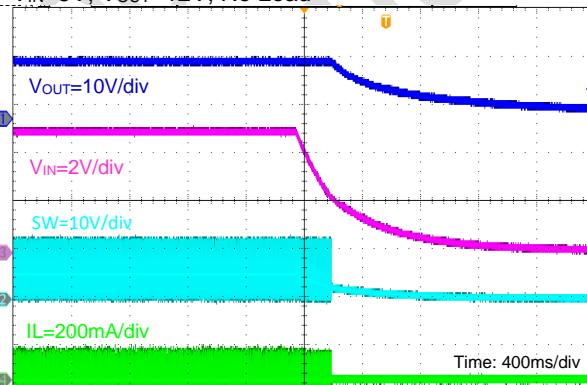

**VIN Power On**

$V_{in}=5V, V_{out}=12V, I_o=0.5A$

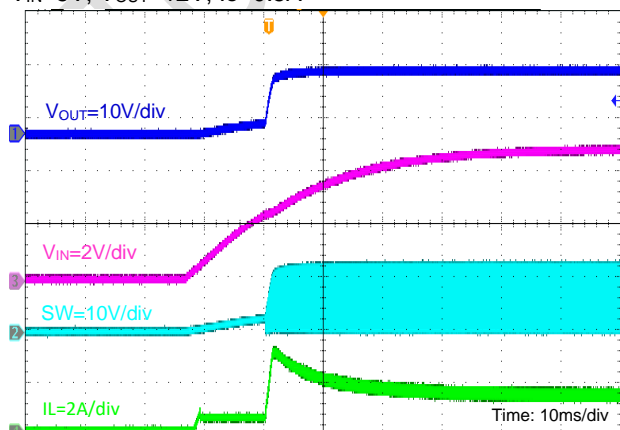

**VIN Power Off**

$V_{in}=5V, V_{out}=12V, I_o=0.5A$

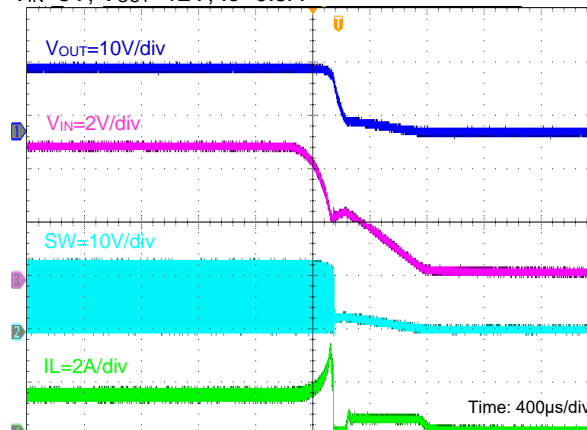

**TYPICAL PERFORMANCE CHARACTERISTICS** (continued)

**Power On through EN**

$V_{IN}=5V, V_{OUT}=12V, I_{OUT}=0.5A$

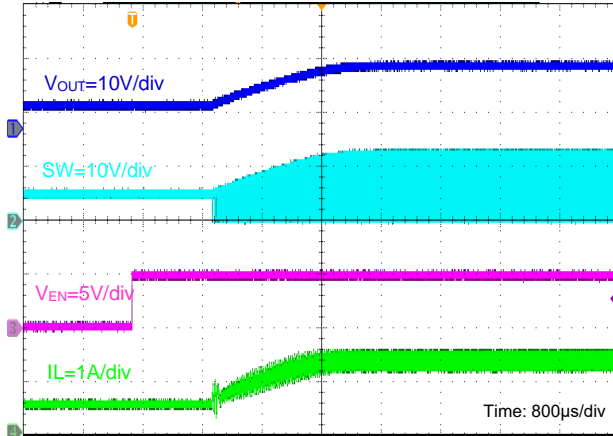

**Power Off through EN**

$V_{IN}=5V, V_{OUT}=12V, I_{OUT}=0.5A$

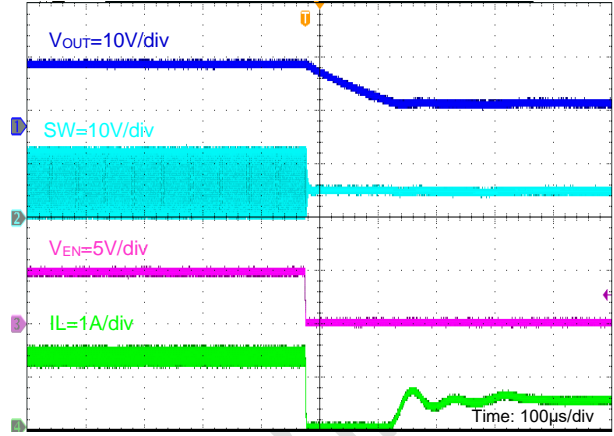

**Load Transient**

$V_{IN}=5V, V_{OUT}=12V, I_{OUT}=0.1A \text{ to } 0.5A$

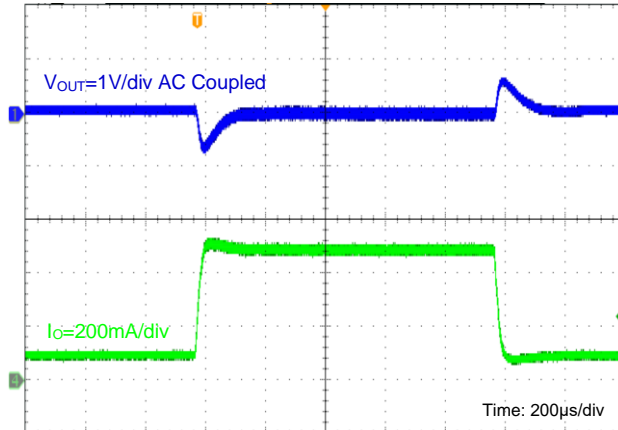

**Load Transient**

$V_{IN}=5V, V_{OUT}=12V, I_{OUT}=0.1A \text{ to } 0.3A$

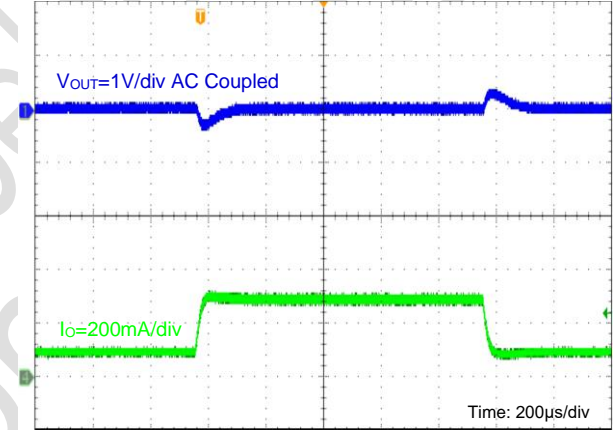

**Overt Current Limit Entrance**

$V_{IN}=5V, V_{OUT}=12V, I_{OUT}=0.5A \text{ to } 1A$

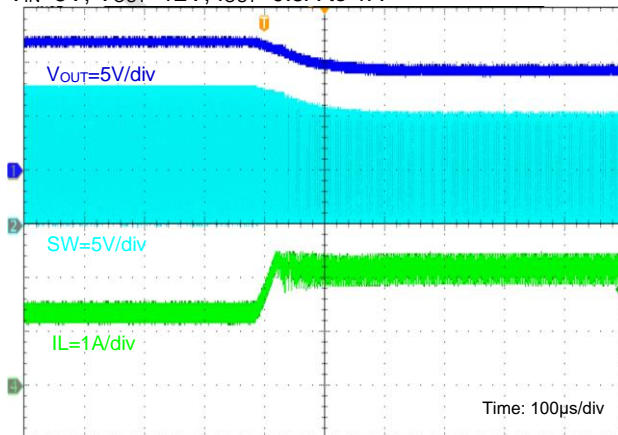

**Overt Current Limit Release**

$V_{IN}=5V, V_{OUT}=12V, I_{OUT}=1A \text{ to } 0.5A$

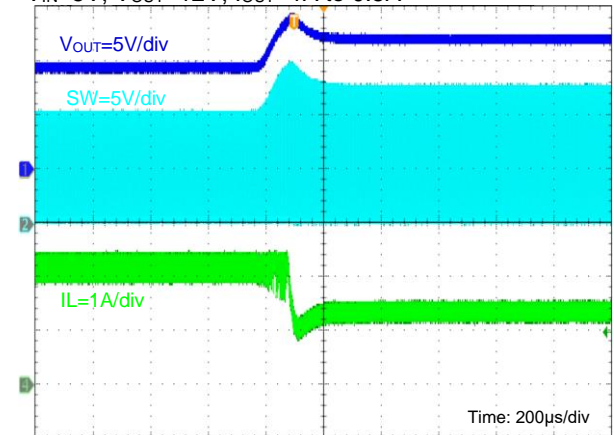

## PACKAGE INFORMATION

### SOT23-6

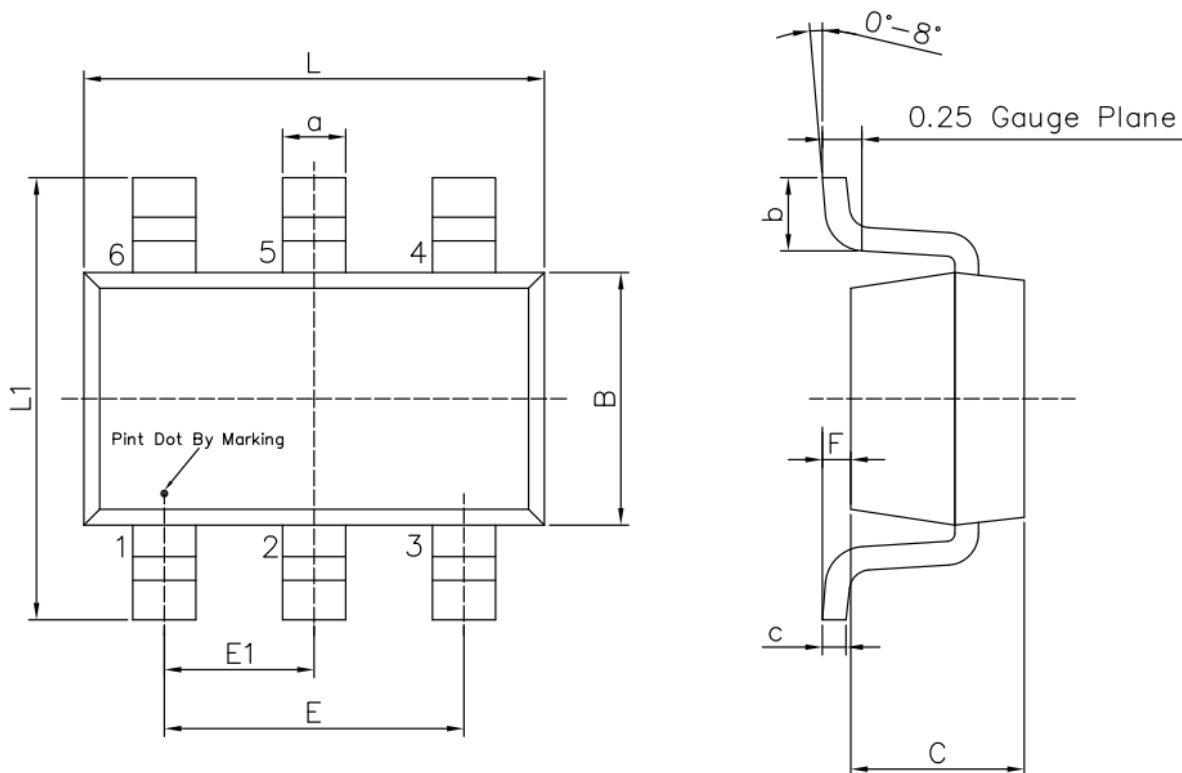

Unit: mm

Symbol	Dimensions In Millimeters		Symbol	Dimensions In Millimeters	
	Min	Max		Min	Max
L	2.82	3.02	E1	0.85	1.05
B	1.50	1.70	a	0.35	0.50
C	0.90	1.30	c	0.10	0.20
L1	2.60	3.00	b	0.35	0.55
E	1.80	2.00	F	0	0.15

**Note:**

- 1) All dimensions are in millimeters.
- 2) Package length does not include mold flash, protrusion or gate burr.
- 3) Package width does not include inter lead flash or protrusion.
- 4) Lead popularity (bottom of leads after forming) shall be 0.10 millimeters max.
- 5) Pin 1 is lower left pin when reading top mark from left to right.

**TAPE AND REEL INFORMATION**

**TAPE DIMENSIONS: SOT23-6**

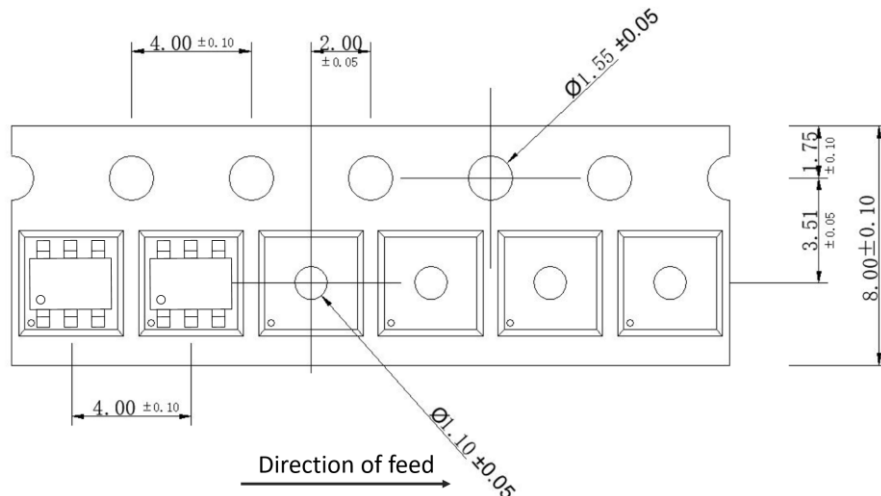

**REEL DIMENSIONS: SOT23-6**

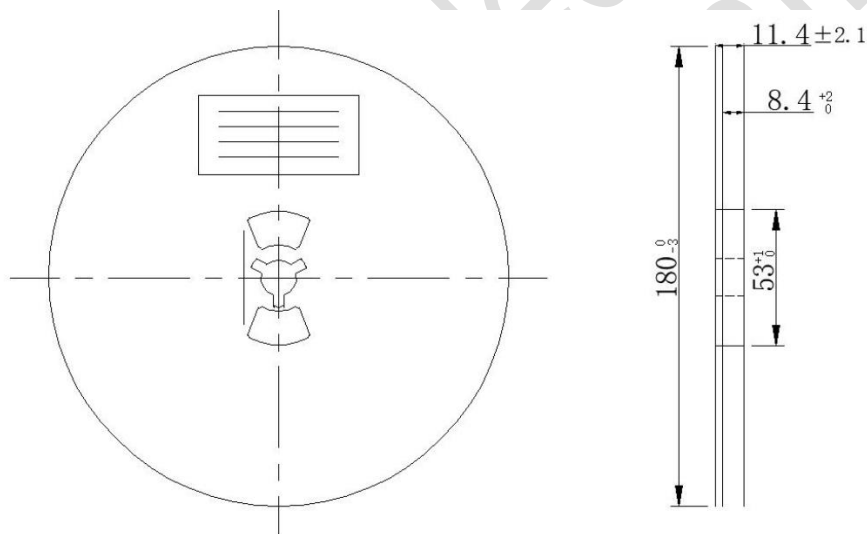

**Note:**

- 1) All Dimensions are in Millimeter
- 2) Quantity of Units per Reel is 3000
- 3) MSL level is level 3.

## X-ON Electronics

Largest Supplier of Electrical and Electronic Components

*Click to view similar products for [Switching Controllers](#) category:*

*Click to view products by [TMI](#) manufacturer:*

Other Similar products are found below :

[NCP1218AD65R2G](#) [NCP1234AD100R2G](#) [NCP1244BD065R2G](#) [NCP1336ADR2G](#) [NCP6153MNTWG](#) [NCP81005MNTWG](#)  
[NCP81101BMNTXG](#) [NCP81205MNTXG](#) [SJ6522AG](#) [SJE6600](#) [AZ7500BMTR-E1](#) [IR35215MTRPBF](#) [SG3845DM](#) [NCP4202MNR2G](#)  
[NCP4204MNTXG](#) [NCP6132AMNR2G](#) [NCP81102MNTXG](#) [NCP81141MNTXG](#) [NCP81203MNTXG](#) [NCP81206MNTXG](#) [NX2155HCUPTR](#)  
[UBA2051C](#) [IR35201MTRPBF](#) [FSL4110LRLX](#) [NCP1015ST65T3G](#) [NCP1240AD065R2G](#) [NCP1240FD065R2G](#) [NCP1336BDR2G](#)  
[NCP1361BABAYSNT1G](#) [NCP1230P100G](#) [NX2124CSTR](#) [SG2845M](#) [NCP1366BABAYDR2G](#) [NCP81101MNTXG](#) [TEA19362T/1J](#)  
[NCP81174NMNTXG](#) [NCP4308DMTTWG](#) [NCP4308DMNTWG](#) [NCP4308AMTTWG](#) [NCP1366AABAYDR2G](#) [NCP1256ASN65T1G](#)  
[NCP1251FSN65T1G](#) [NCP1246BLD065R2G](#) [MB39A136PFT-G-BND-ERE1](#) [NCP1256BSN100T1G](#) [LV5768V-A-TLM-E](#)  
[NCP1365BABCYDR2G](#) [NCP1365AABCYDR2G](#) [IR35204MTRPBF](#) [MCP1633T-E/MG](#)