

800mA Li-ion Linear Charger with Thermal Regulation

FEATURES

- Programmable Charge Current Up to 1A
- No MOSFET, Sense Resistor or Blocking Diode Required
- Charge Single Cell Li-Ion Battery Directly from USB Port
- Trickle Current, Constant Current and Constant Voltage Operation with Thermal Regulation to Maximize Charge Rate without Overheating
- $<1\mu\text{A}$ Battery Quiescent Current
- Preset 4.2V Battery Charge Voltage with $\pm 1\%$ Accuracy
- Automatically Recharge
- Charge Statue Indication Pin
- SOT23-5 Package

APPLICATIONS

- Portable Devices
- Power Bank
- Charging Docks and Cradles
- Bluetooth Applications

GENERAL DESCRIPTION

The TMI4054 is a complete constant-current and constant-voltage linear charger for single cell Li-ion battery application.

The default battery charge voltage is fixed at 4.2V, and the charging current can be programmed by external resistor on PROG pin. The charging current could be programmed up to 800mA with good system thermal design. When the charging current drops to 1/10 programmed charging current value after the BAT voltage reaching battery charge voltage, TMI4054 automatically terminates the charge cycle with charging current becomes to 0 and $\overline{\text{CHAG}}$ pin status changes. Thermal regulation function can regulate charging current to limit the die temperature during high power condition or high ambient temperature application.

When the input supply is removed, the TMI4054 automatically enters low current state with less $1\mu\text{A}$ current dropping from battery side. Its SOT23-5 package and less external components make TMI4054 suited for portable applications.

TYPICAL APPLICATIONS

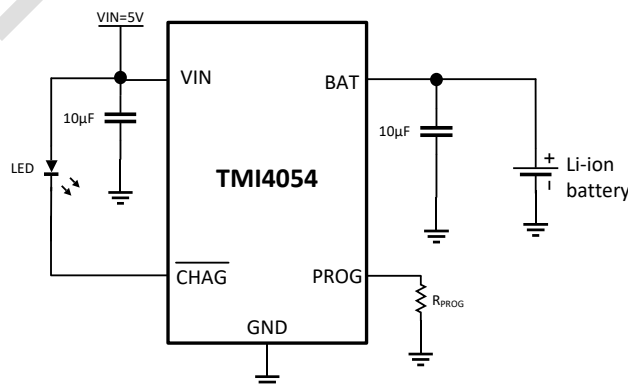
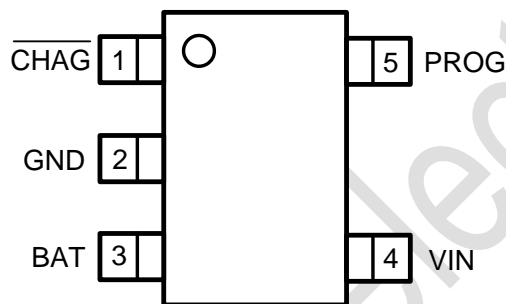

Figure 1. Basic Application Circuit

ABSOLUTE MAXIMUM RATINGS (Note1)

Parameter	Min	Max	Unit
Input Supply voltage	-0.3	10	V
BAT, PROG voltage	-0.3	7	V
$\overline{\text{CHAG}}$ voltage	-0.3	10	V
Junction Temperature <small>(Note2)</small>		150	°C
Power Dissipation		1	W
Storage Temperature Range	-65	150	°C
Lead Temperature (Soldering, 10s)		260	°C

PACKAGE/ORDER INFORMATION



SOT23-5

Top Mark: T1AXXX (T1A: Device Code, XXX: Inside Code)

Part Number	Package	Top mark	Quantity/ Reel
TMI4054	SOT23-5	T1AXXX	3000

TMI4054 devices are Pb-free and RoHS compliant.

PIN DESCRIPTIONS

Pin	Name	Function
1	$\overline{\text{CHAG}}$	Charging status indicator pin. When the device is in charging status, a 5mA typical pull-down current inner $\overline{\text{CHAG}}$ pin is enabled. When charging process is termination, pull-down current is disable and the $\overline{\text{CHAG}}$ is high-impedance status. If no battery is present on BAT pin, LED on pin is blinking.
2	GND	Ground Pin
3	BAT	Battery Connection Pin.
4	VIN	Input Power Source. Connect to a wall adapter or USB Port.
5	PROG	Charging Current Program Pin. The charging Current is Programmed by Connected R_{PROG} Resistor to GND.

ESD RATING

Items	Description	Value	Unit
V_{ESD}	Human Body Model for all pins	± 2000	V

JEDEC specification JS-001
RECOMMENDED OPERATING CONDITIONS

Items	Description	Min	Max	Unit
Voltage Range	IN	BAT+0.3	8	V
T_J	Operating Junction Temperature Range	-40	150	°C

ELECTRICAL CHARACTERISTICS

($V_{IN}=5V$, $T_A = 25^{\circ}C$, unless otherwise noted.)

Parameter	Conditions	Min	Typ	Max	Unit
BAT Charging Voltage		4.158	4.20	4.242	V
VIN Supply Current	Charging mode, $R_{PROG}=2k\Omega$		5		mA
	Standby mode, $V_{BAT}=4.3V$		1	5	mA
	Shutdown mode, PROG is floating		30	55	μA
BAT Pin Output Current	$R_{PROG}=10k\Omega$	90	110	130	mA
	$R_{PROG}=2k\Omega$	490	550	610	mA
	Standby mode, $V_{BAT}=4.3V$, $V_{IN}=5V$	0	-2.5	-8	μA
	Shutdown mode, PROG is floating		1	4	μA
	Sleep mode, $V_{BAT}=4.0V$, $V_{IN}=0V$		-0.5	-1	μA
Trickle Charge current	$R_{PROG}=2k\Omega$, $V_{BAT}=2.5V$	40	55	70	mA
Trickle Charge Threshold Voltage	V_{BAT} from low to high	2.8	2.9	3.0	V
	V_{BAT} from high to low	2.6	2.7	2.9	V
PROG Shutdown Voltage	V_{PROG} rising	2.2	2.4	2.6	V
	V_{PROG} Hysteresis		0.2		V
VIN-BAT Lockout Threshold Voltage	V_{IN} from low to high		210		mV
Termination Current Threshold	$R_{PROG}=2k\Omega$	30	55	70	mA
PROG Pin Voltage	$R_{PROG}=2k\Omega$, $V_{BAT}=3.8V$		1.2		V
CHAG current	$V_{BAT}=3.8V$		5		mA
Recharge BAT Threshold Voltage	$V_{FLOAT} - V_{RECH}$		180		mV
Junction Temperature Regulation			130		$^{\circ}C$
Power MOSFET On-Resistance			0.5		Ω
PROG Pin Pull-Up Current			1		μA

Note 1: Absolute Maximum Ratings are those values beyond which the life of a device may be impaired.

Note 2: T_J is calculated from the ambient temperature T_A and power dissipation PD according to the following formula: $T_J = T_A + (PD) \times \theta_{JA}$.

OPERATION DESCRIPTION

The TMI4054 is a single cell lithium-ion battery charger using a trickle-current / constant-current / constant voltage algorithm. It can deliver up to 800mA charge current (using a good designed PCB) with the final charge voltage accuracy of $\pm 1\%$. The TMI4054 includes an internal power MOSFET and thermal regulation circuitry so the basic charger circuit requires only 2-3 external components. Moreover, the TMI4054 is able to operate from a USB power source.

Normal Charge Cycle

A charge cycle begins when the voltage at the VIN pin rises above VIN-BAT Lockout threshold level and the program resistor is connected from the PROG pin to ground or when a battery is connected to the charger output. If the BAT pin is less than 2.9V, the charger enters trickle charge mode. In this mode, the TMI4054 supplies approximately 1/10 the programmed charge current to bring the battery voltage up to a safe level for full current charging.

When the BAT pin voltage rises above 2.9V, the charger enters constant-current mode, where the programmed charge current is supplied to the battery. When the BAT pin approaches the final BAT charge voltage (4.2V), the TMI4054 enters constant-voltage mode and the charge current begins to decrease. When the charge current drops to 1/10 the programmed charge current, the charge cycle is terminated with charging current changed to 0A. Then the status of $\overline{\text{CHAG}}$ is changed from pull-down to high impedance. The charger is going to work again whenever the BAT voltage drops recharge voltage threshold.

Programming Charge Current

The charge current is programmed with a single resistor from the PROG pin to ground. The battery charge current is typical 1100 times the current out of the PROG pin. The program resistor and the charge current are calculated using the following equations:

$$R_{\text{PROG}}(\text{k}\Omega) = \frac{1100(\text{V})}{I_{\text{CHG}}(\text{mA})}$$

The charge current out of the BAT pin can be determined at any time by monitoring the PROG pin voltage using the following equation:

$$I_{\text{CHG}}(\text{mA}) = \frac{V_{\text{PROG}}(\text{V})}{R_{\text{PROG}}(\text{k}\Omega)} \times 1100$$

Charge Status Indicator

The charge status output $\overline{\text{CHAG}}$ has two different states: strong pull-down with typical 5mA pull-down current and high impedance. The strong pull-down state will light the right LED. The charge status can be indicated by the LED.

Thermal Limiting

An internal thermal feedback loop reduces the programmed charge current if the die temperature attempts to rise above a preset value of approximately 130°C. This feature protects the TMI4054 from excessive temperature and allows the user to push the limits of the power handling capability of a given circuit board without risk of damaging the TMI4054. The charge current can be set according to typical (not worst-case)

ambient temperature with the assurance that the charger will automatically reduce the charging current in worst-case conditions.

Manual Shutdown

At any point in the charge cycle, the TMI4054 can be put into shutdown mode by removing R_{PROG} thus floating the PROG pin. This reduces the battery drain current to less than $2\mu A$ and the supply current to less than $50\mu A$ typically. A new charge cycle can be initiated by reconnecting the program resistor.

Automatic Recharge

Once the charge cycle is terminated, the TMI4054 continuously monitors the voltage on the BAT pin using a comparator with a 2ms filter time. A charge cycle restarts when the battery voltage falls below full-charges status. This ensures that the battery is kept at or near a fully charged condition and eliminates the need for periodic charge cycle initiations. \overline{CHAG} output enters pull-down state during recharge cycles.

TOLL Microelectronic

FUNCTIONAL BLOCK DIAGRAM

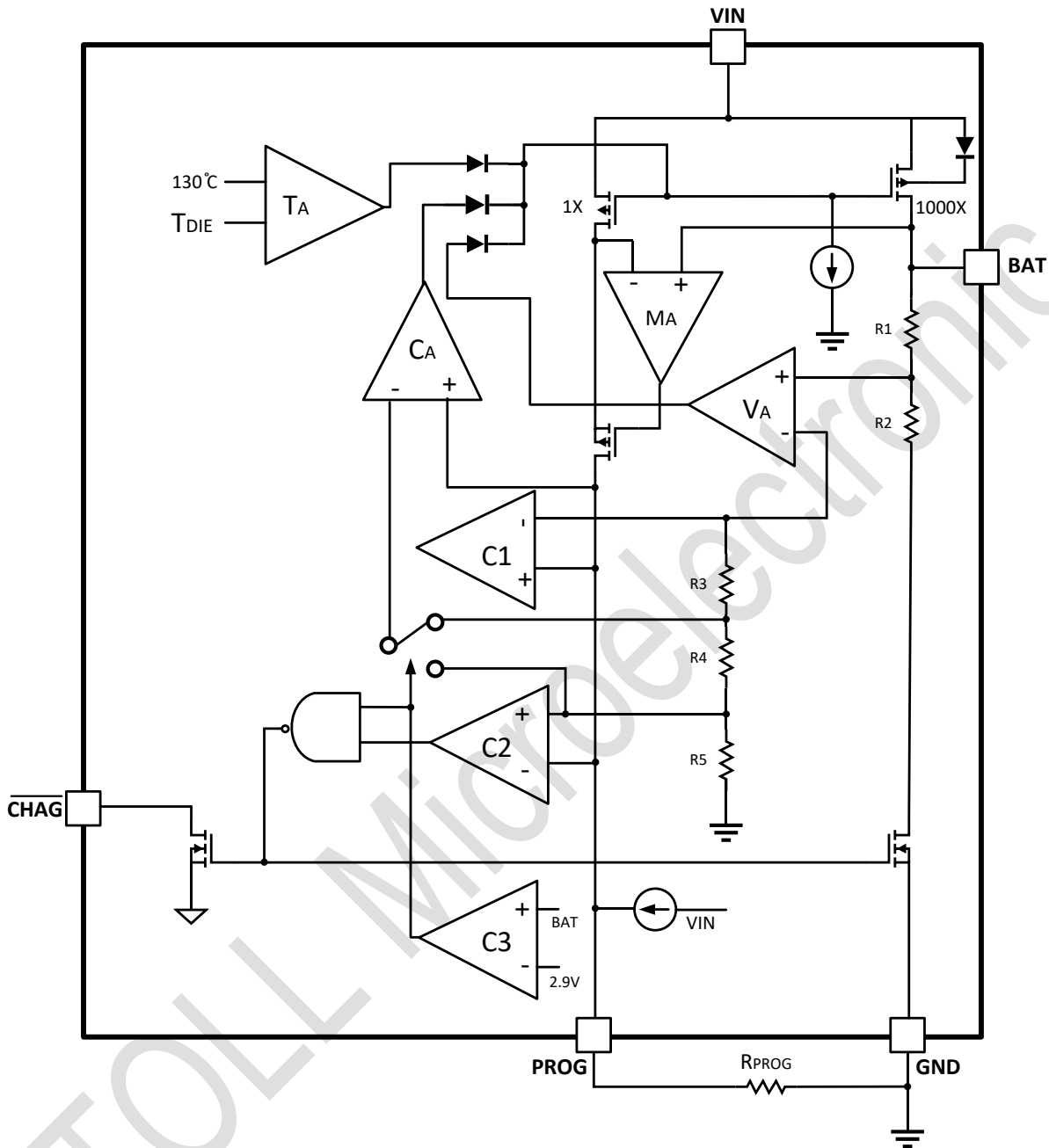
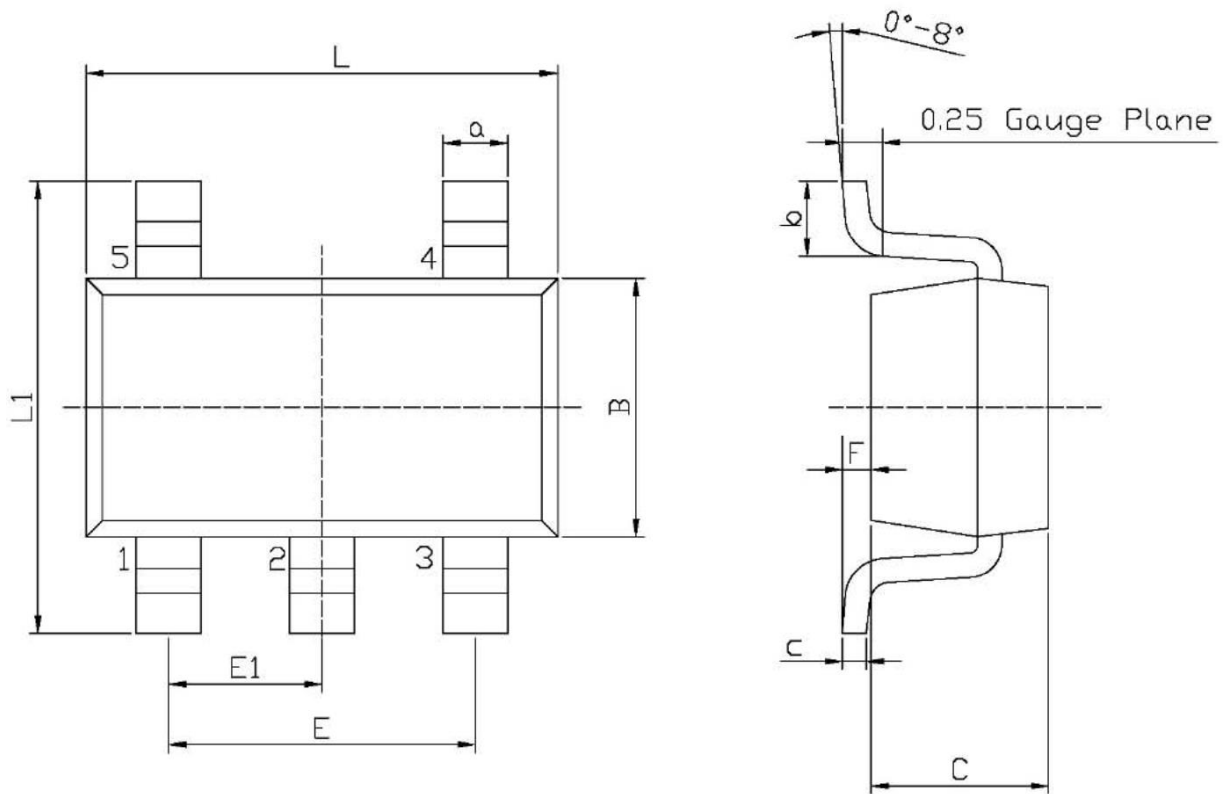

Figure 2. TMI4054 Block Diagram

PACKAGE INFORMATION

SOT23-5



Unit: mm

Symbol	Dimensions In Millimeters		Symbol	Dimensions In Millimeters	
	Min	Max		Min	Max
L	2.82	3.02	E1	0.85	1.05
B	1.50	1.70	a	0.35	0.50
C	0.90	1.30	c	0.10	0.20
L1	2.60	3.00	b	0.35	0.55
E	1.80	2.00	F	0	0.15

Note:

- 1) All dimensions are in millimeters.
- 2) Package length does not include mold flash, protrusion or gate burr.
- 3) Package width does not include inter lead flash or protrusion.
- 4) Lead popularity (bottom of leads after forming) shall be 0.10 millimeters max.
- 5) Pin 1 is lower left pin when reading top mark from left to right.

TAPE AND REEL INFORMATION

TAPE DIMENSIONS:

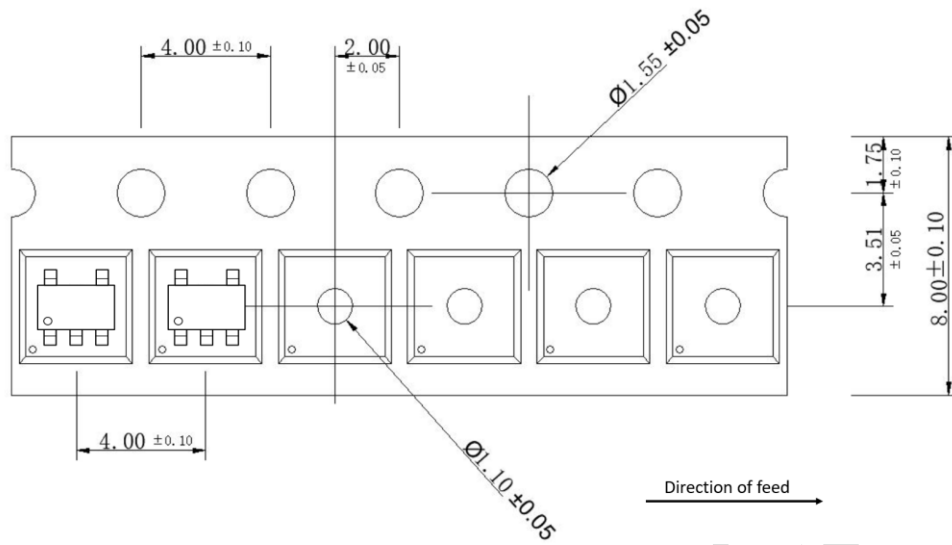

REEL DIMENSIONS:

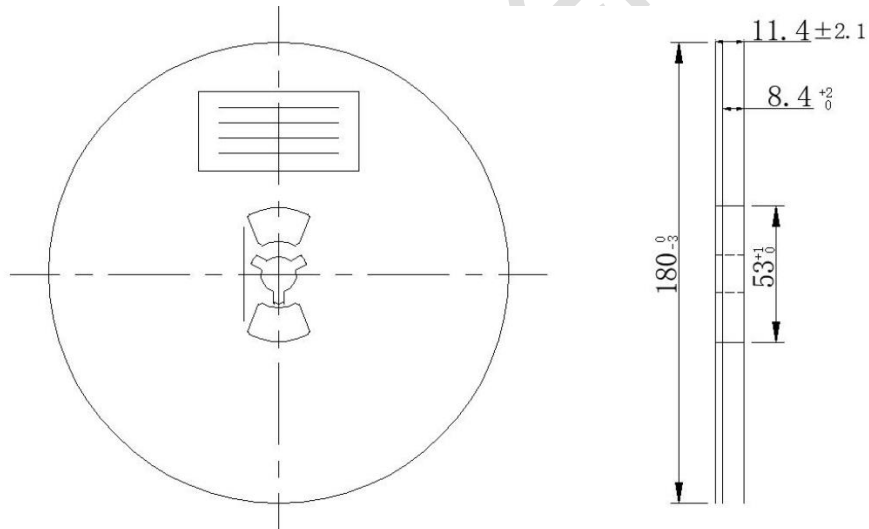

Note:

- 1) All Dimensions are in Millimeter
- 2) Quantity of Units per Reel is 3000
- 3) MSL level is level 3.

X-ON Electronics

Largest Supplier of Electrical and Electronic Components

Click to view similar products for [Battery Management](#) category:

Click to view products by [TMI](#) manufacturer:

Other Similar products are found below :

[VN5R003HTR-E](#) [NCP1851BFCCT1G](#) [NCP1855FCCT1G](#) [FAN54063UCX](#) [LC05132C01NMTTGTG](#) [ISL78714ANZ](#) [CM1104-EH](#) [CM1104-DBB](#) [CM1104-MBB](#) [XC6801A421MR-G](#) [ISL95521BHRZ](#) [ISL95521BIRZ](#) [MP2639AGR-P](#) [S-82D1AAE-A8T2U7](#) [S-82D1AAA-A8T2U7](#) [S-8224ABA-I8T1U](#) [MC33772CTA1AE](#) [MC33772CTC0AE](#) [BQ28Z610DRZR-R1](#) [MCP73832-4ADI/MC](#) [MCP73832T-2DCIMC](#) [MCP73833T-AMIMF](#) [MCP73833T-AMI/UN](#) [MCP73838-NVI/MF](#) [MCP73213-A6BI/MF](#) [MCP73831-2ACI/MC](#) [MCP73831T-2ATIMC](#) [MCP73832-2ACI/MC](#) [MCP73832T-3ACIMC](#) [MCP73833T-FCI/MF](#) [MCP73853-IML](#) [BQ25895RTWR](#) [BQ29704DSER](#) [BQ78Z100DRZR](#) [ISL78610ANZ](#) [FAN5403UCX](#) [NCP367DPMUECTBG](#) [FAN54015BUCX](#) [MAX8934BETI+](#) [BQ24311DSGR](#) [BQ25100HYFPR](#) [BQ29707DSER](#) [MAX17048G+T10](#) [BQ24130RHRLR](#) [BQ25120AYFPR](#) [BQ29703DSER](#) [BQ771807DPJR](#) [BQ25120AYFPT](#) [MAX17055ETB+T](#) [MAX17710GB+T](#)