

1A Li-ion Linear Charger with Thermal Regulation

FEATURES

- Programmable Charge Current Up to 1A
- No MOSFET, Sense Resistor or Blocking Diode Required
- Charge Single Cell Li-Ion Battery Directly from USB Port
- Trickle Current, Constant Current and Constant Voltage Operation with Thermal Regulation to Maximize Charge Rate without Overheating
- <math><1\mu\text{A}</math> Battery Quiescent Current
- Preset Battery Charging Voltage with $\pm 1\%$ Accuracy
TMI4056E: 4.2V
TMI4056EH: 4.35V
- Automatically Recharge
- Charge Statue Indication Pins
- ESOP8 Package

APPLICATIONS

- Portable Devices
- Power Bank
- Charging Docks and Cradles
- Bluetooth Applications

TYPICAL APPLICATIONS

GENERAL DESCRIPTION

The TMI4056E and TMI4056EH are complete constant-current and constant-voltage linear charger for single cell Li-ion battery application.

The default battery charge voltage is fixed at 4.2V for TMI4056E and 4.35V for TMI4056EH, and the charging current can be programmed by external resistor on PROG pin. The charging current could be programmed up to 1A with good system thermal design. When the charging current drops to 1/10 programmed charging current value after the BAT voltage reaching battery charge voltage, TMI4056E and TMI4056EH automatically terminate the charge cycle with charging current becomes to 0 and $\overline{\text{CHAG}}$ and $\overline{\text{STDBY}}$ pins status change. Thermal regulation function can regulate charging current to limit the die temperature during high power condition or high ambient temperature application.

When the input supply is removed, the TMI4056E and TMI4056EH automatically enter low current state with less $1\mu\text{A}$ current dropping from battery side. The ESOP8 package and less external components make TMI4056E and TMI4056EH suited for portable applications.

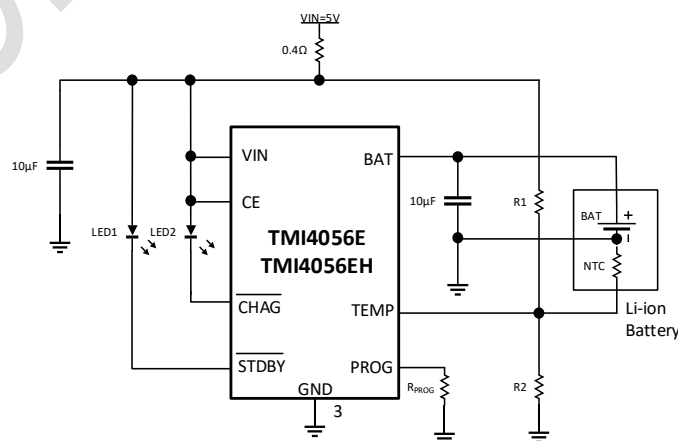
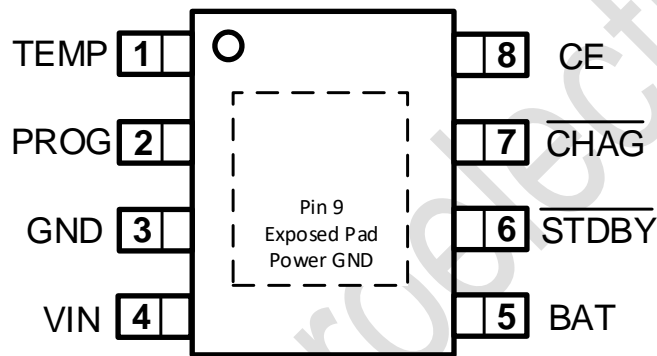

Figure 1. Basic Application Circuit

ABSOLUTE MAXIMUM RATINGS (Note1)

Parameter	Min	Max	Unit
Input Supply voltage	-0.3	10	V
CE voltage	-0.3	10	V
BAT, CE, TEMP, PROG voltage	-0.3	7	V
$\overline{\text{CHAG}}$, $\overline{\text{STDBY}}$ voltage	-0.3	7	V
Junction Temperature (Note2)	-	150	°C
Power Dissipation	-	2	W
Storage Temperature Range	-65	150	°C
Lead Temperature (Soldering, 10s)	-	260	°C

PACKAGE/ORDER INFORMATION



ESOP8

Top Mark: T4056E/YYXXX (T4056E: Device Code, YYXXX: Inside Code) for TMI4056E
Top Mark: T4056EH/YYXXX (T4056EH: Device Code, YYXXX: Inside Code) for TMI4056EH

Part Number	Package	Top Mark	Quantity/ Reel
TMI4056E	ESOP8	T4056E YYXXX	3000
TMI4056EH	ESOP8	T4056EH YYXXX	3000

TMI4056E and TMI4056EH devices are Pb-free and RoHS compliant.

PIN DESCRIPTIONS

Pin	Name	Function
1	TEMP	Temperature thermal sensing input pin. Connect NTC of battery package to TEMP pin. If the TEMP voltage is smaller than 45% VIN or is higher 80% VIN, the charging process is disabled. If TEMP is pulled to GND, temperature thermal sensing function is disable.
2	PROG	Charging Current Program Pin. The charging Current is Programmed by Connected R _{PROG} Resistor to GND.
3	GND	Ground Pin
4	VIN	Input Power Source. Connect to a wall adapter or USB Port.
5	BAT	Battery Connection Pin.
6	$\overline{\text{STDBY}}$	Charging termination indicator pin. When charging process is termination, a 5mA typical pull-down current inner $\overline{\text{STDBY}}$ pin is enabled; When the device is in charging status, pull-down current is disable and the $\overline{\text{STDBY}}$ is high-impedance status. If no battery is present on BAT pin, LED on pin is blinking.
7	$\overline{\text{CHAG}}$	Charging status indicator pin. When the device is in charging status, a 5mA typical pull-down current inner $\overline{\text{CHAG}}$ pin is enabled. When charging process is termination, pull-down current is disable and the $\overline{\text{CHAG}}$ is high-impedance status. If no battery is present on BAT pin, LED on pin is blinking.
8	CE	Charging enable pin. Drive this pin to high enable level, TMI4056E is in normal status and charge function is enabled. Drive this pin to low level, charge function is disabled. Do not leave CE floating.
9	Exposed pad	The exposed pad is needed to connect to GND.

ESD RATING

Items	Description	Value	Unit
V _{ESD}	Human Body Model for all pins	±2000	V

JEDEC specification JS-001

RECOMMENDED OPERATING CONDITIONS

Items	Description	Min	Max	Unit
Voltage Range	IN	V _{BAT} + 0.3	8	V
T _J	Operating Junction Temperature Range	-40	150	°C

THERMAL RESISTANCE

Items	Description	Value	Unit
θ _{JA}	Junction-to-ambient thermal resistance	60	°C/W

ELECTRICAL CHARACTERISTICS

($V_{IN}=5V$, $T_A = 25^{\circ}C$, unless otherwise noted.)

Parameter	Conditions	Min	Typ	Max	Unit
BAT Charging Voltage	TMI4056E	4.158	4.20	4.242	V
	TMI4056EH	4.306	4.35	4.394	V
VIN Supply Current	Charging mode, $R_{PROG}=2k\Omega$		5		mA
	Standby mode, $V_{BAT}=4.3V$		1	5	mA
	Shutdown mode, PROG is floating		30	55	μA
BAT Pin Output Current	$R_{PROG}=10k\Omega$	90	110	130	mA
	$R_{PROG}=2k\Omega$	490	550	610	mA
	$R_{PROG}=1k\Omega$		1100		mA
	Standby mode, $V_{BAT}=4.3V$, $V_{IN}=5V$	0	-2.5	-8	μA
	Shutdown mode, PROG is floating		1	4	μA
	Sleep mode, $V_{BAT}=4.0V$, $V_{IN}=0V$		-0.5	-1	μA
Trickle Charge current	$R_{PROG}=2k\Omega$, $V_{BAT}=2.5V$	40	55	70	mA
Trickle Charge Threshold Voltage	V_{BAT} from low to high	2.8	2.9	3.0	V
	V_{BAT} from high to low	2.6	2.7	2.9	V
PROG Shutdown Voltage	V_{PROG} Rising	2.2	2.4	2.6	V
	V_{PROG} Hysteresis		0.2		V
VIN–BAT Lockout Threshold Voltage	V_{IN} from low to high		210		mV
Termination Current Threshold	$R_{PROG}=2k\Omega$	30	55	70	mA
PROG Pin Voltage	$R_{PROG}=2k\Omega$, $V_{BAT}=3.8V$		1.2		V
CHAG Pull-down Current	$V_{BAT}=3.8V$		5		mA
STDBY Pull-down Current	$V_{BAT}=3.8V$		5		mA
Recharge BAT Threshold Voltage	$V_{BAT} - V_{RECH}$		180		mV
Junction Temperature Regulation			130		$^{\circ}C$
CE Rising Enable Threshold			3	3.2	V
CE Falling Disable Threshold		1.5	1.7		V
Power MOSFET On-Resistance			0.5		Ω
V_{TEMP_High} Threshold			80		%VIN
V_{TEMP_Low} Threshold			45		%VIN
TEMP Function Disable Threshold		0	0.3		V
PROG Pin Pull-Up Current			1		μA

Note 1: Absolute Maximum Ratings are those values beyond which the life of a device may be impaired.

Note 2: T_J is calculated from the ambient temperature T_A and power dissipation PD according to the following formula: $T_J = T_A + (PD) \times \theta_{JA}$.

OPERATION DESCRIPTION

The TMI4056E and TMI4056EH are single cell lithium-ion battery chargers using a trickle-current / constant-current / constant voltage algorithm. It can deliver up to 1A charge current (using a good designed PCB) with the final BAT charge voltage accuracy of $\pm 1\%$. The TMI4056E and TMI4056EH include an internal power MOSFET and thermal regulation circuitry so the basic charger circuit requires only few external components. Moreover, TMI4056E and TMI4056EH could operate from a USB power source.

Normal Charge Cycle

A charge cycle begins when the voltage at the VIN pin rises above VIN-BAT Lockout threshold level and CE pin is enabled. The program resistor connected from the PROG pin to ground sets charging current. If the BAT pin is less than 2.9V typically, the charger enters trickle charge mode. In this mode, the TMI4056E and TMI4056EH supplies approximately 1/10 the programmed charge current to bring the battery voltage up to a safe level for full current charging.

When the BAT pin voltage rises above 2.9V typically, the charger enters constant-current mode, where the programmed charge current is supplied to the battery. When the BAT pin approaches the final BAT charge voltage (4.2V for TMI4056E and 4.35V for TMI4056EH), the TMI4056E and TMI4056EH enter constant-voltage mode and the charge current begins to decrease. When the charge current drops to 1/10 the programmed charge current, the charge cycle is terminated with charging current changed to 0A. Then the status of $\overline{\text{CHAG}}$ is changed from pull-down to high impedance and the status of $\overline{\text{STDBY}}$ is changed from high impedance to pull-down. The charger is going to work again whenever the BAT voltage drops recharge voltage threshold.

Programming Charge Current

The charge current is programmed with a single resistor from the PROG pin to ground. The battery charge current is typical 1100 times the current out of the PROG pin. The program resistor and the charge current are calculated using the following equations:

$$R_{\text{PROG}}(\text{k}\Omega) = \frac{1100(\text{V})}{I_{\text{CHG}}(\text{mA})}$$

The charge current out of the BAT pin can be determined at any time by monitoring the PROG pin voltage using the following equation:

$$I_{\text{CHG}}(\text{mA}) = \frac{V_{\text{PROG}}(\text{V})}{R_{\text{PROG}}(\text{k}\Omega)} \times 1100$$

Charge Status Indicator

The charge status output $\overline{\text{CHAG}}$ and $\overline{\text{STDBY}}$ have two different states: strong pull-down with typical 5mA pull-down current and high impedance. The strong pull-down state will light the right LEDs. The charge statue can be indicated by the LEDs.

Thermal Limiting

An internal thermal feedback loop reduces the programmed charge current if the die temperature attempts to rise above a preset value of approximately 130°C. This feature protects the TMI4056E and TMI4056EH

from excessive temperature and allows the user to push the limits of the power handling capability of a given circuit board without risk of damaging the TMI4056E and TMI4056EH. The charge current can be set according to typical (not worst-case) ambient temperature with the assurance that the charger will automatically reduce the charging current in worst-case conditions.

Manual Shutdown

At any point in the charge cycle, the TMI4056E and TMI4056EH can be put into shutdown mode by removing R_{PROG} thus floating the PROG pin. This reduces the battery drain current to less than 2μA and the supply current to less than 50μA typically. A new charge cycle can be initiated by reconnecting the program resistor.

Automatic Recharge

Once the charge cycle is terminated, the TMI4056E and TMI4056EH continuously monitor the voltage on the BAT pin using a comparator with a 2ms filter time. A charge cycle restarts when the battery voltage falls below full-charges statue. This ensures that the battery is kept at or near a fully charged condition and eliminates the need for periodic charge cycle initiations. $\overline{\text{CHAG}}$ output enters pull-down state and $\overline{\text{STDBY}}$ enters high impedance state during recharge cycles.

Battery Temperature Monitor

TMI4056E and TMI4056EH integrate battery NTC monitor function to protect battery temperature rising too high or falling too low during the charging process. Connecting TEMP pin to NTC of battery package and divider resistors to VIN and GND are used to set voltage on TEMP pin. TMI4056E and TMI4056EH have two competitors to monitor TEMP pin voltage change with NTC resistance. If TEMP voltage is higher than 80%×VIN, it indicates battery temperature is high or if TEMP voltage is lower than 45%×VIN, it indicates battery temperature is low. Then charging process is disabled. If the TEMP temperature is between 45%×VIN and 80%×VIN, charging process in normal status.

Battery NTC monitor function is about to be shut once the TEMP pin is directly connected to GND. Determine the value of R1 and R2.

The values of R1 and R2 are based on the temperature monitoring range of the battery and the resistance value of the thermistor. See the examples as follows:

Assume that the set battery temperature range is T_L to T_H (where T_L<T_H); the battery uses a negative temperature coefficient thermistor (NTC), R_{TL} is the resistance at temperature T_L, and R_{TH} is the resistance at temperature T_H, then R_{TL}>R_{TH}. So then, the voltage of the TEMP pin at temperature T_L is:

$$V_{\text{TEMPL}} = \frac{R2 // R_{TL}}{R1 + R2 // R_{TL}} \times VIN$$

The voltage of the TEMP pin at temperature T_H is:

$$V_{\text{TEMPH}} = \frac{R2 // R_{TH}}{R1 + R2 // R_{TH}} \times VIN$$

As we know:

$$V_{\text{TEMPL}} = V_{\text{HIGH}} = K_2 \times VIN \quad (K_2 = 0.80)$$

$$V_{\text{TEMPH}} = V_{\text{LOW}} = K_1 \times VIN \quad (K_1 = 0.45)$$

We have:

$$R1 = \frac{R_{TL} R_{TH} (K_2 - K_1)}{(R_{TL} - R_{TH}) K_1 K_2}$$

$$R2 = \frac{R_{TL}R_{TH}(K_2 - K_1)}{R_{TL}(K_1 - K_1K_2) - R_{TH}(K_2 - K_1K_2)}$$

Similarly, if there is a positive temperature coefficient (PTC) thermistor inside of the battery is, we can calculate:

$$R1 = \frac{R_{TL}R_{TH}(K_2 - K_1)}{(R_{TH} - R_{TL})K_1K_2}$$

$$R2 = \frac{R_{TL}R_{TH}(K_2 - K_1)}{R_{TH}(K_1 - K_1K_2) - R_{TL}(K_2 - K_1K_2)}$$

It can be seen from the above derivation that the temperature range to be set is independent of the power supply voltage VCC, and is only related to R1, R2, R_{TH} and R_{TL}; R_{TH} and R_{TL} can be consulted by referring to the relevant battery manual or get through experimental test.

In practical applications, if we only pay attention to the temperature characteristics of one end, such as overheat protection, R2 can be removed. The derivation of R1 is also going to become simple.

If temperature monitor function is not needed, TEMP pin could be pulled down to lower than 0.3V typically and charging process is not control by TEMP pin status.

FUNCTIONAL BLOCK DIAGRAM

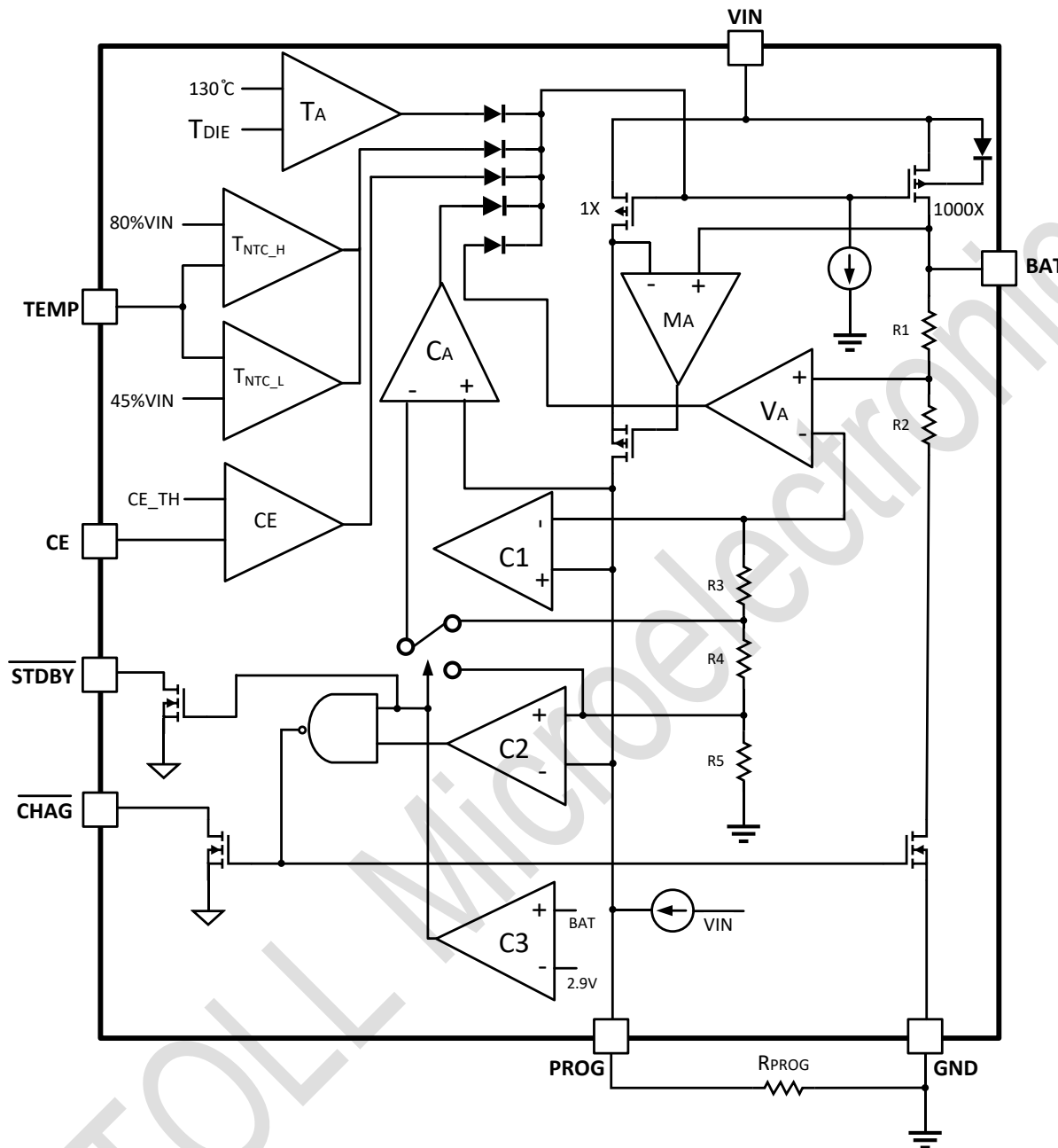
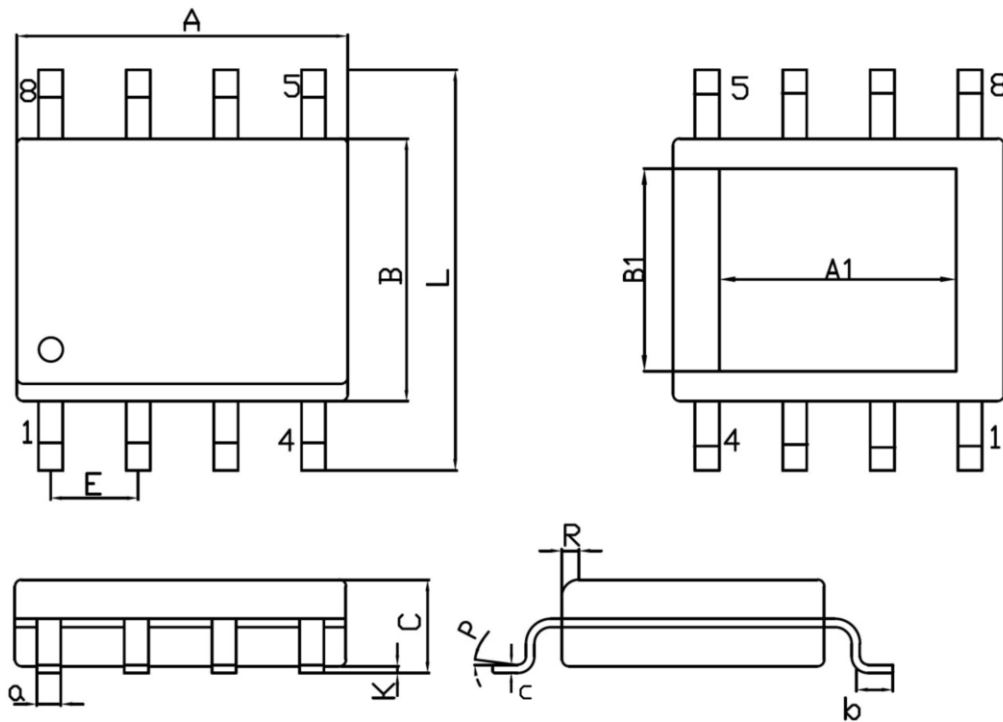

Figure 2. TMI4056E and TMI4056EH Block Diagram

PACKAGE INFORMATION

ESOP8



Symbol	Dimensions In Millimeters		Symbol	Dimensions In Millimeters	
	Min	Max		Min	Max
A	4.70	5.10	C	1.35	1.75
B	3.70	4.10	a	0.35	0.49
L	6.00	6.40	R	0.30	0.60
E	1.27 BSC		P	0°	7°
K	0.02	0.10	b	0.40	1.25
A1	3.1	3.5	B1	2.2	2.6
			c	0.203	0.243

Note:

- 1) All dimensions are in millimeters.
- 2) Package length does not include mold flash, protrusion or gate burr.
- 3) Package width does not include inter lead flash or protrusion.
- 4) Lead popularity (bottom of leads after forming) shall be 0.10 millimeters max.
- 5) Pin 1 is lower left pin when reading top mark from left to right.

TAPE AND REEL INFORMATION

TAPE DIMENSIONS: ESOP8

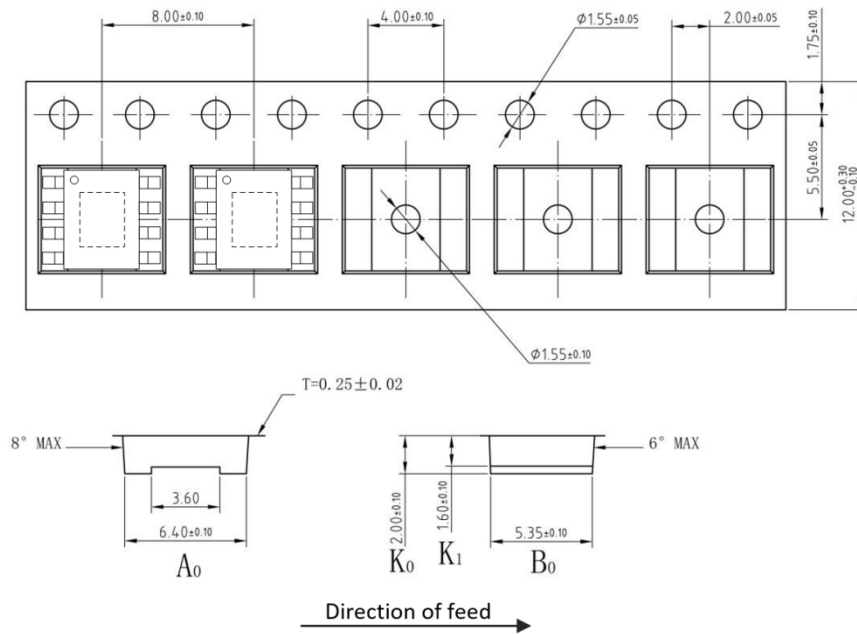

REEL DIMENSIONS: ESOP8

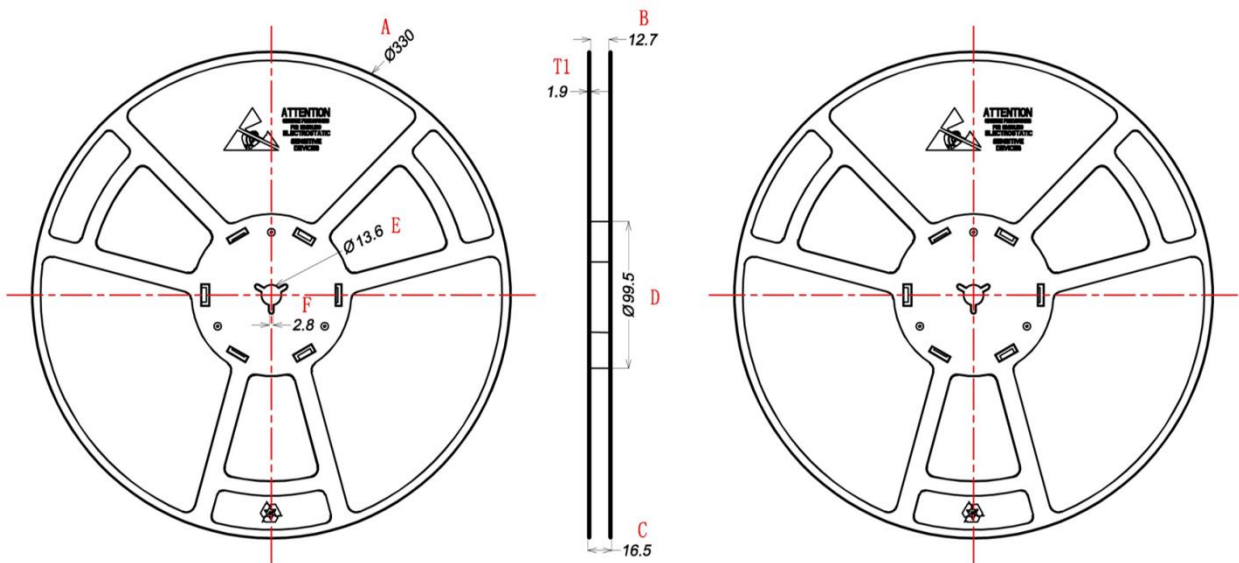

Unit: mm

A	B	C	D	E	F	T1
$\phi 330 \pm 1$	12.7 ± 0.5	16.5 ± 0.3	$\phi 99.5 \pm 0.5$	$\phi 13.6 \pm 0.2$	2.8 ± 0.2	1.9 ± 0.2

Note:

- 1) All Dimensions are in Millimeter
- 2) Quantity of Units per Reel is 3000
- 3) MSL level is level 3.

X-ON Electronics

Largest Supplier of Electrical and Electronic Components

Click to view similar products for [Battery Management](#) category:

Click to view products by [TMI](#) manufacturer:

Other Similar products are found below :

[VN5R003HTR-E](#) [NCP1855FCCT1G](#) [FAN54063UCX](#) [LC05132C01NMTTGTG](#) [ISL78714ANZ](#) [CM1104-EH](#) [CM1104-DBB](#) [CM1104-MBB](#)
[XC6801A421MR-G](#) [ISL95521BHRZ](#) [ISL95521BIRZ](#) [MP2639AGR-P](#) [S-82D1AAE-A8T2U7](#) [S-82D1AAA-A8T2U7](#) [S-8224ABA-I8T1U](#)
[MC33772CTC0AE](#) [BQ28Z610DRZR-R1](#) [MCP73832-4ADI/MC](#) [MCP73832T-2DCIMC](#) [MCP73833T-AMIMF](#) [MCP73833T-AMI/UN](#)
[MCP73838-NVI/MF](#) [MCP73213-A6BI/MF](#) [MCP73831-2ACI/MC](#) [MCP73831T-2ATIMC](#) [MCP73832-2ACI/MC](#) [MCP73832T-3ACIMC](#)
[MCP73833T-FCI/MF](#) [MCP73853-IML](#) [BQ25895RTWR](#) [BQ29704DSER](#) [BQ78Z100DRZR](#) [ISL78610ANZ](#) [FAN5403UCX](#)
[NCP367DPMUECTBG](#) [FAN54015BUCX](#) [MAX8934BETI+](#) [BQ24311DSGR](#) [BQ25100HYFPR](#) [BQ29707DSER](#) [MAX17048G+T10](#)
[BQ24130RHLLR](#) [BQ25120AYFPR](#) [BQ29703DSER](#) [BQ771807DPJR](#) [BQ25120AYFPT](#) [MAX17055ETB+T](#) [MAX17710GB+T](#)
[MAX14634EWC+](#) [BQ25121AYFPR](#)