

# 500mA LNB-Power Supply & Control Voltage Regulator

## FEATURES

- High Efficiency: Up to 90%
- Low noise output to avoid sensitivity of Can Tuner and DISH's LNA dropping down
- Noise 40mV@20MHz BWL
- Single chip solution on 650mVpp
- 22kHz TONE with  $10\mu\text{s}$   $T_{\text{rise}}/T_{\text{fall}}$  for less Transferring noise
- LNB Voltages (2 levels: 14V and 19V) compatible with common standards, Push-pull output stage minimizes 14V  $\rightarrow$  19V and 19V  $\rightarrow$  14V output transition times
- External 22kHz TONE input
- Integrated DC/DC BOOST converter and high efficiency (typ. 87%) with integrated Power MOSFET
- 1.0MHz Switch Frequency BOOST
- Integrated low Noise Linear Regulator
- 5.0V, 3.3V, 2.5V, 1.8V, logic compatible
- Internal Short, OCP, OTP protection
- ESOP8 package

## APPLICATIONS

- LNB Power supply for DVB-S/S2/ABS
- Digital STB
- Satellite TV cards

## GENERAL DESCRIPTION

Intended for analog and digital satellite receivers/sat-TV, sat-OC cards, the TMI8037 is a monolithic voltage regulator and interface IC, packaged in ESOP8, specifically designed to provide the 14V/19V power supply with high efficiency and the 22kHz TONE signaling to the LNB down-converter in the antenna dish or to the multi-switch box. TMI8037 consists of a BOOST converter and a low-noise linear regulator along with the circuitry required for TONE injection and pin controllable interface. The device makes the total LNB supply design simple, efficient and compact with low external component count.

The external modulation input (TONE pin) can accept a tone modulated DiSEqC command and transfer it symmetrically to the output to meet DiSEqC 1.x protocol.

## EFFICIENCY

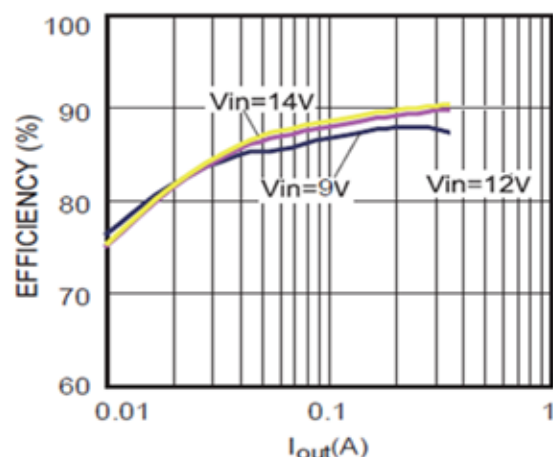

## APPLICATIONS CIRCUITS

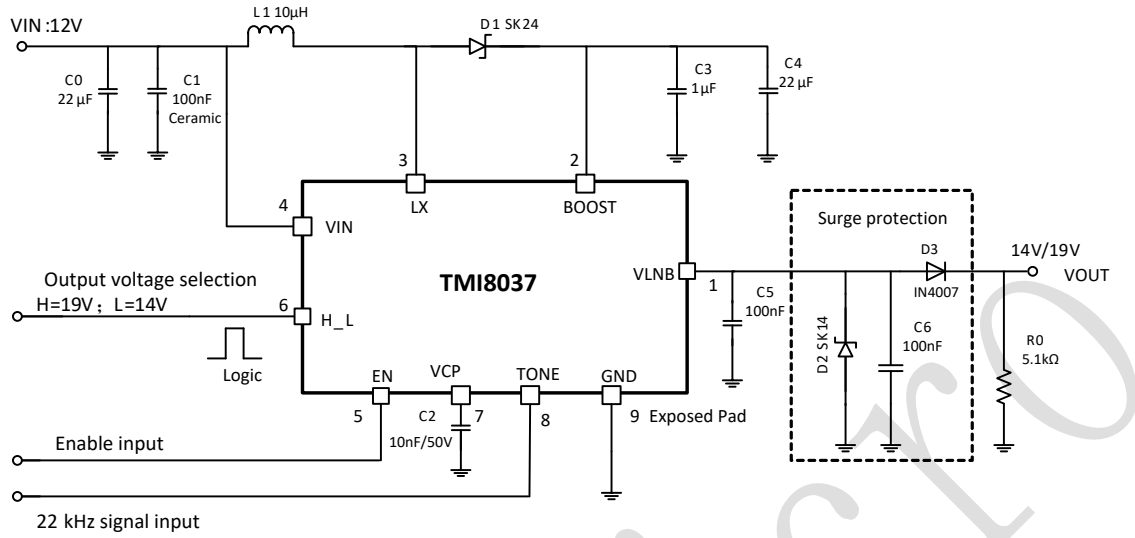

Figure 1. Basic Application Circuit

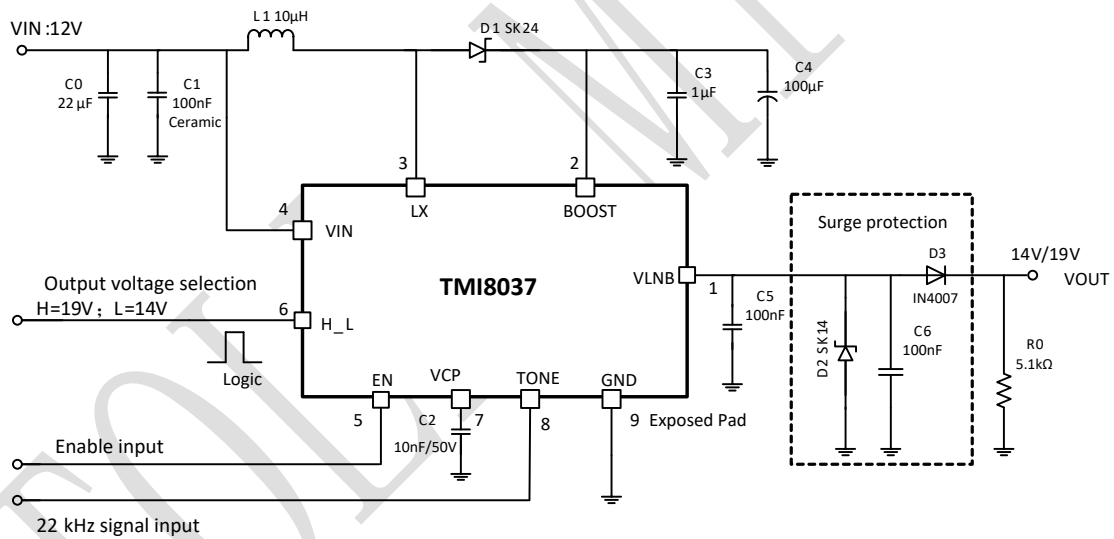
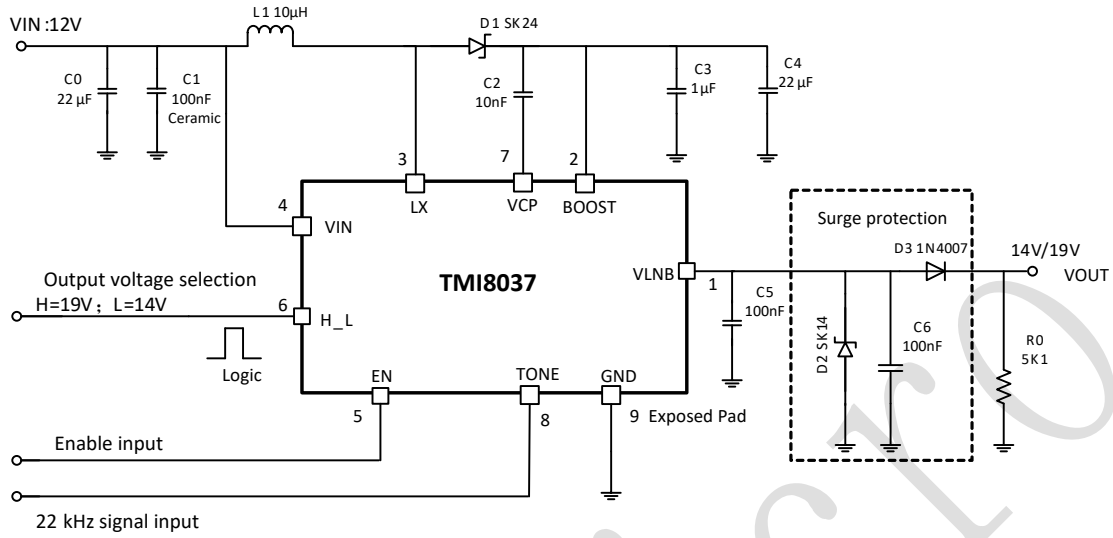
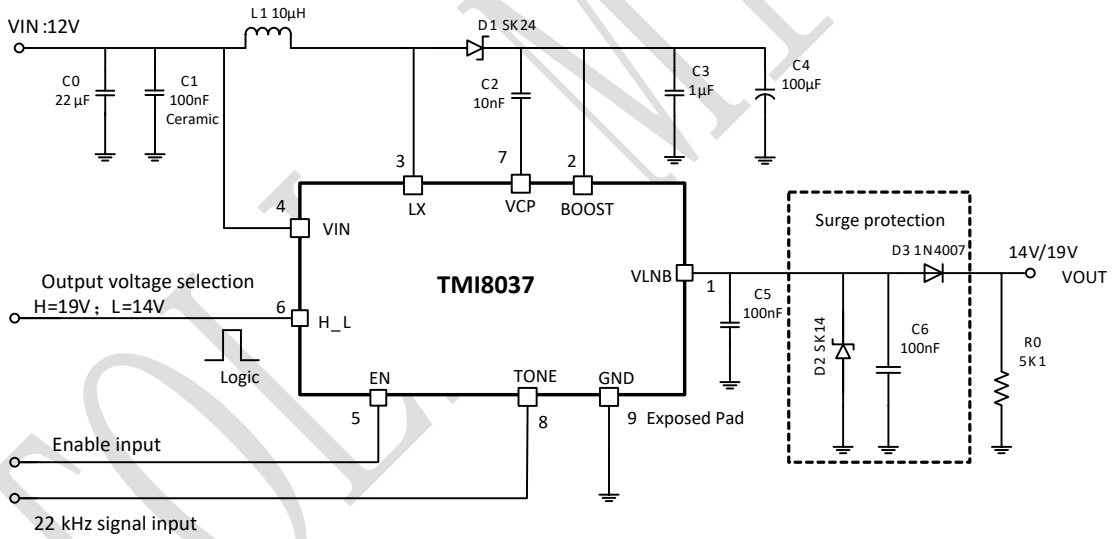

Figure 2. Basic Application Circuit

**APPLICATIONS CIRCUITS** (Continued)



**Figure 3. Basic Application Circuit**

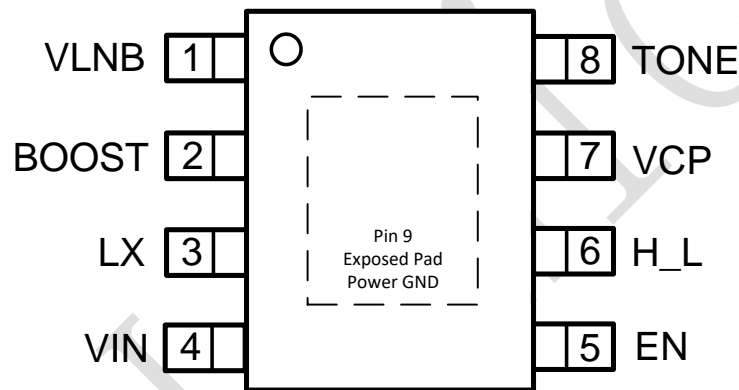

**Figure 4. Basic Application Circuit**

## ABSOLUTE MAXIMUM RATINGS (Note 1)

Parameter	Value	Unit
EN Supply Voltage Range	-0.3~24	V
BOOST Voltage Range	-0.3~30	V
VLNB Voltages Range	-0.3~24	V
LX Voltage Range	-2~30	V
VCP Voltage Range	-0.3~30	V
H_L, TONE Voltage Range	-0.3~6	V
Junction Temperature (Note 2)	-40~150	°C
Storage Temperature	-50~150	°C
Lead Temperature (Soldering,10s)	260	°C

## PACKAGE/ORDER INFORMATION



ESOP8

Top Mark: T8037/YYXXX (T8037: Device Code, YYXXX: Inside Code)

Part Number	Package	Top mark	Quantity/ Reel
TMI8037	ESOP8	T8037/YYXXX	3000

TMI8037 devices are Pb-free and RoHS compliant.

## PIN FUNCTIONS

Pin	Name	Function
1	VLNB	Output Pin of the LNB.
2	BOOST	BOOST converter output voltage sense, and internal LDO's input terminal.
3	LX	DC-DC converter switch node connection. This pin is connected to inductor.
4	VIN	Power Supply Input.
5	EN	When this pin is low, the output is disabled. Setting EN = 1 enables the output voltage.
6	H_L	Output Voltage set input pin, high: 19V, Low: 14V.
7	VCP	Charge Pump for LDO supply. A 10nF capacitor could be connected between VCP pin to GND or to BOOST. If the capacitor is connected to GND, the recommended capacitor voltage rating should be 50V.
8	TONE	22kHz TONE signal input pin. Please keep this pin low if no 22kHz signal input.
9	GND	Power Ground (Exposed pad).

## ESD RATING

Items	Description	Value	Unit
V <sub>ESD</sub>	Human Body Model for all pins	±2000	V

JEDEC specification JS-001

## RECOMMENDED OPERATING CONDITIONS

Items	Description	Min	Max	Unit
Voltage Range	IN	9	14	V
T <sub>J</sub>	Operating Junction Temperature Range	-40	125	°C

## ELECTRICAL CHARACTERISTICS (Note 3)

Over operating free-air temperature range (unless otherwise noted)  $V_{IN} = 12V$ ,  $T_A = 25^\circ C$

Parameter	Symbol	Conditions	Min	Typ	Max	Unit
<b>Supply Voltage</b>						
Operating supply voltage range	$V_{IN}$		9	12	14	V
Input UVLO Threshold	$V_{UVLO}$	$V_{IN}$ rising		7.5		V
Input UVLO Hysteresis	$V_{UVLO\_HY}$			0.6		V
Operating Supply Current	$I_{IN}$	EN="1", VOUT=19V, TONE_IN=0V		10		mA
		EN="1", VOUT=19V, 22kHz TONE Input		25		mA
Disable Supply Current	$I_{SDN}$	EN="0"		0.2		mA
<b>Output Voltage</b>						
Output Voltage	$V_{OUT}$	EN="1", H_L="1" ILOAD=200mA (Note 4)	18.0		19.0	V
		EN="1", H_L="0" ILOAD=200mA (Note 4)	13.0		14.0	V
Linear Regulator Drop Voltage	$V_{DROP}$	EN="1", ILOAD=450mA	0.6		1.2	V
VIN Line Regulation	$R_{LINE}$	VIN=9~14V, VOUT=19V		4	40	mV
DC Control Switching Transitions	TDCTRAN	14V->19V ILOAD=200mA	0.4	1	1.4	ms
		19V->14V ILOAD=200mA	0.4	1	1.4	ms
Power on VOUT Rise Time	TRVOUT	ILOAD=200mA		1.5		ms
VOUT output Load Regulation	$R_{LOAD}$	ILOAD=0~450mA, VOUT=19V Slow Rate=255mA/us, CLOAD=0.2μF		30	80	mV
Ripple and Noise on VOUT Output	$V_{NOISE}$	20MHz BWL		40		mV
Output Current Limit	$I_{LIMIT}$	VOUT=19V or OUT=14V	500	600	750	mA
		VOUT output short	140	240	340	mA
<b>BOOST DC/DC</b>						
Boost DC/DC Switching Frequency	$F_{BOOST}$	EN="1"	0.8	1	1.2	MHz
Switch on Resistance	$R_{dson}$	ILOAD=450mA		120		mΩ
BOOST Maximum Duty	$D_{BST\_MAX}$			80		%
BOOST Minimum on Time	$D_{BST\_MIN}$			0		%
BOOST Current Limit	$I_{BST\_LIM}$			1.5		A

**ELECTRICAL CHARACTERISTICS** (continued)

Parameter	Symbol	Conditions	Min	Typ	Max	Unit
<b>Short and Overload Protection</b>						
Dynamic Overload ON Time	T <sub>on</sub>	Output shorted to GND		75		ms
Dynamic Overload OFF Time	T <sub>off</sub>	Output shorted to GND		1600		ms
Thermal Shutdown Threshold	T <sub>SDN</sub>			150		°C
Thermal Shutdown Hysteresis	T <sub>SDN_HY</sub>			25		°C
<b>TONE</b>						
Input TONE Frequency Range	F <sub>TONE</sub>		20	22		kHz
VOUT output TONE Amplitude, peak to peak	V <sub>PP_TONE</sub>	ILOAD=0~450mA, CLOAD=100nF	600		800	mV
VOUT output TONE Duty	D <sub>TONE</sub>	ILOAD=0~450mA, CLOAD=570nF		50		%
VOUT output TONE Rising Time	T <sub>RISE_TON</sub>	ILOAD=0~450mA, CLOAD=570nF	6	8	10	μs
VOUT output TONE Falling Time	T <sub>FALL_TON</sub>	ILOAD=0~450mA, CLOAD=570nF	6	8	10	μs
TONE Pin Input Leakage Current	I <sub>TON_LEAK</sub>			5		μA
<b>H_L</b>						
H_L High Logic Input	V <sub>HL_INH</sub>		1.5			V
H_L Low Logic Input	V <sub>HL_INL</sub>				0.55	V
H_L Pin Input Leakage	I <sub>HL_LEAK</sub>			5		μA
<b>EN</b>						
EN High Logic Input	V <sub>EN_INH</sub>		1.5			V
EN Low Logic Input	V <sub>EN_INL</sub>				0.55	V
EN PIN Maximum Input Current	I <sub>EN_MAX</sub>				15	μA

**Note 1:** Absolute Maximum Ratings are those values beyond which the life of a device may be impaired.

**Note 2:** T<sub>J</sub> is calculated from the ambient temperature T<sub>A</sub> and power dissipation P<sub>D</sub> according to the following formula: T<sub>J</sub> = T<sub>A</sub> + (P<sub>D</sub>) × θ<sub>JA</sub>.

**Note 3:** 100% production test at +25°C. Specifications over the temperature range are guaranteed by design and characterization.

**Note 4:** Output voltage is tested with a diode in series between VLNB pin and VOUT.

## OPERATION

The TMI8037 single output LNB supply utilizes built-in DC/DC step-up converters, which operate from 9V to 14V and outputs the low noise voltage set by H-L pin, and accepts a tone modulated DiSEqC command and transfers it symmetrically to the output to meet DiSEqC 1.x protocol.

### DiSEqC Encoding

The TONE accepts an externally modulated TONE command and in turn modulates the VOUT symmetrically to meet the DiSEqC 1.x and with few more external components to meet DiSEqC 2.0 transmit protocol. Burst coding of the TONE can be accomplished due to the fast response of the TONE pin.

### Linear Regulator

The output linear regulator is designed to source 500mA continuous current and 650mA peak. In order to minimize the power dissipation, the output voltage of the internal step-up converter is adjusted to allow the linear regulator to work at a minimum dropout of 1 V typical (Load current =500mA) between the BOOST and VLNB pin. The BOOST pin is capable of withstanding a back voltage of 27V.

### Short and Over Load Protection

When the LDO current exceeds the preset over current threshold for a period of 65ms, the device enters a  $T_{ON} = 75ms / T_{OFF} = 1600ms$  routine. The device returns to normal operation after a successful soft-start cycle.

This IC is protected against overheating. When the junction temperature exceeds +150°C (typical), the step-up converter and the linear regulator are shut-off. When the junction is cooled down to +125°C (typical), normal operation is resumed.

### TONE input

Once EN is pulled high, after a 50ms delay before applying 22kHz, 50% square pulse on TONE in generates the DISEQ TONE (+/-350mV) on the output VLNB. If there is no 22kHz signal applied on TONE pin, please keep TONE pin low.



**FUNCTIONAL BLOCK DIAGRAM**

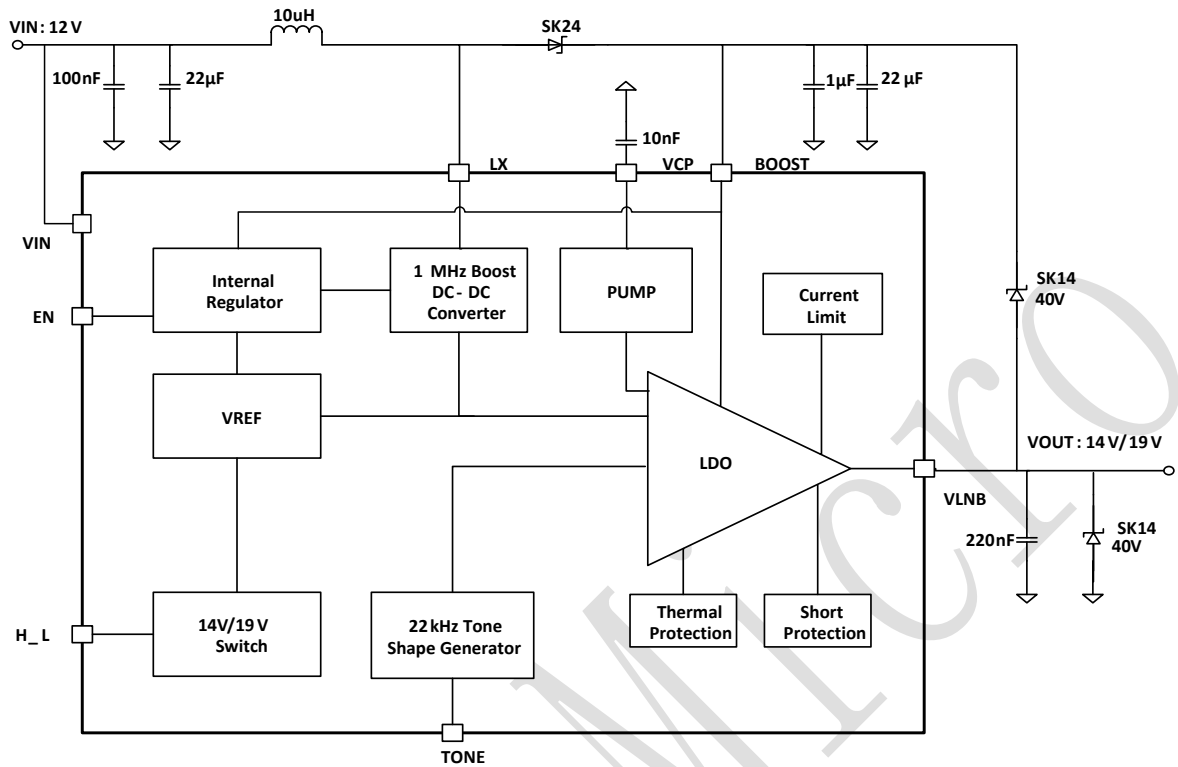
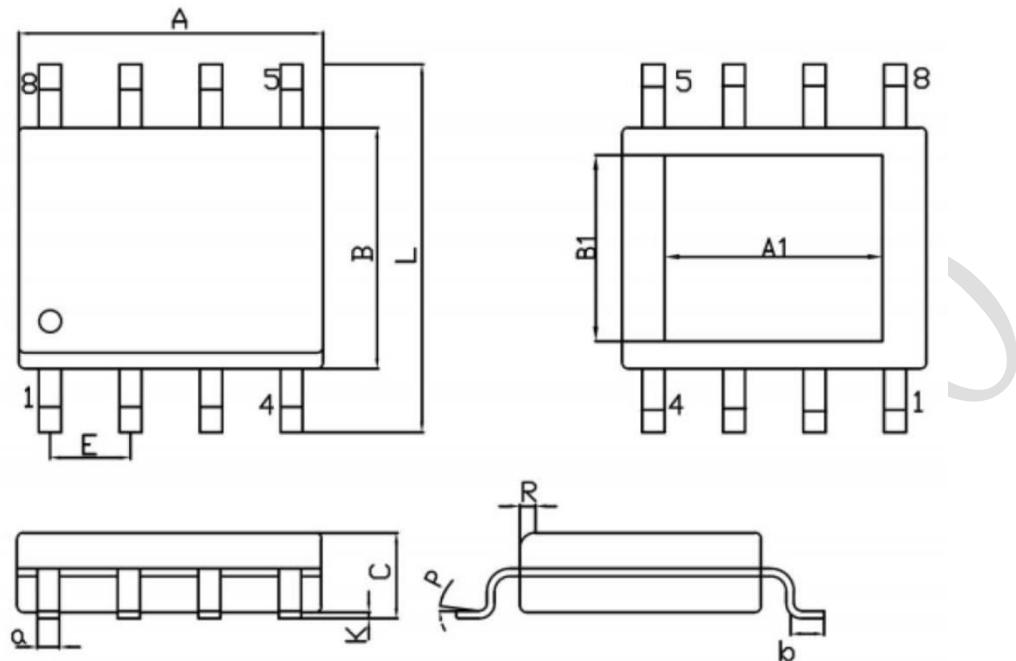

Figure 5. TMI8037 Block Diagram

## PACKAGE INFORMATION

### ESOP8



Unit: mm

Symbol	Dimensions In Millimeters		Symbol	Dimensions In Millimeters	
	Min	Max		Min	Max
A	4.70	5.10	C	1.35	1.75
B	3.70	4.10	a	0.35	0.49
L	6.00	6.40	R	0.30	0.60
E	1.27 BSC		P	0°	7°
K	0.02	0.10	b	0.40	1.25
A1	3.1	3.5	B1	2.2	2.6

**Note:**

- 1) All dimensions are in millimeters.
- 2) Package length does not include mold flash, protrusion or gate burr.
- 3) Package width does not include inter lead flash or protrusion.
- 4) Lead popularity (bottom of leads after forming) shall be 0.10 millimeters max.
- 5) Pin 1 is lower left pin when reading top mark from left to right.

**TAPE AND REEL INFORMATION**

**TAPE DIMENSIONS:**

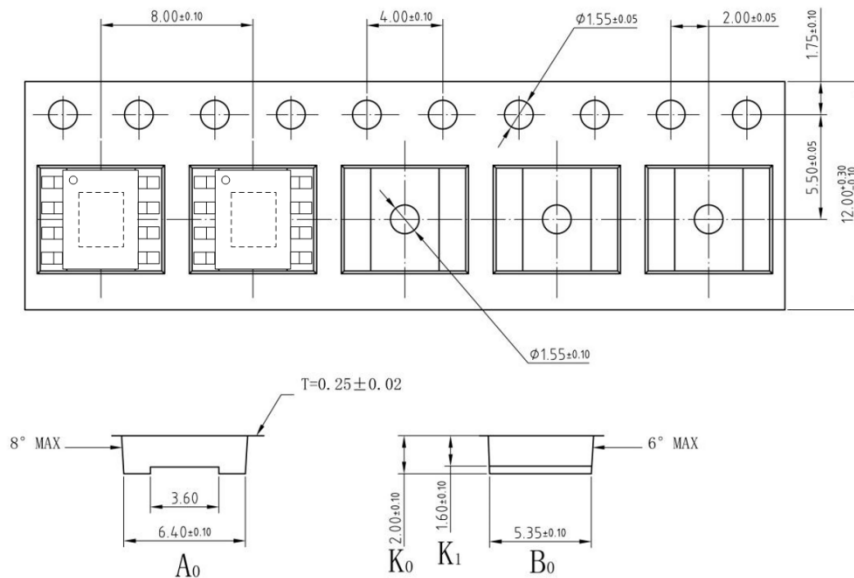

**REEL DIMENSIONS:**

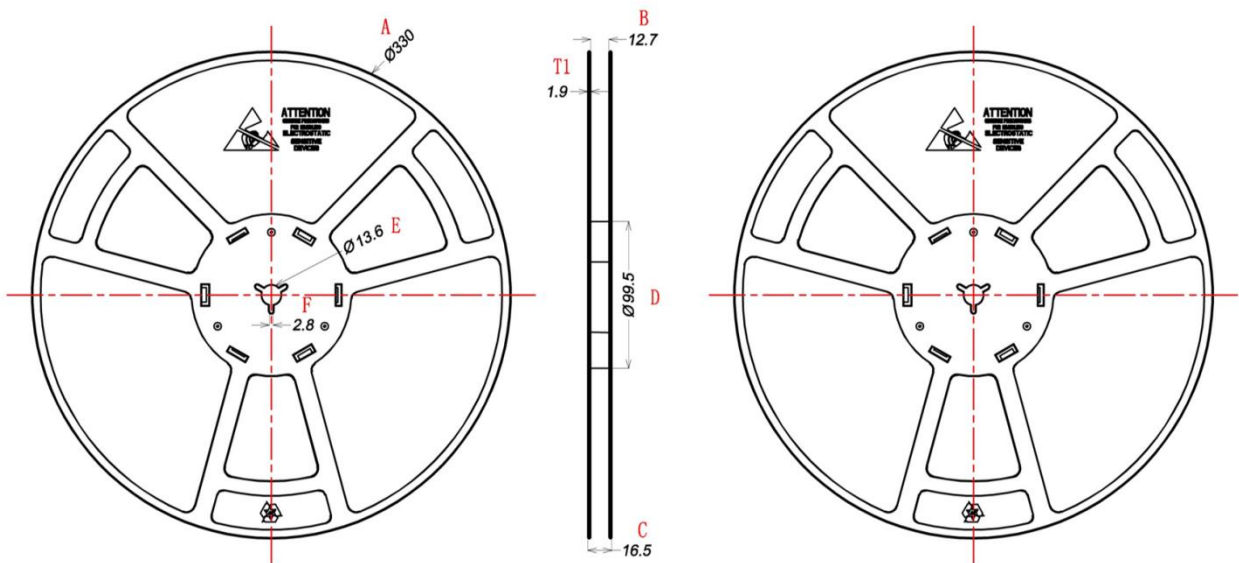

Unit: mm

A	B	C	D	E	F	T1
$\phi 330 \pm 1$	$12.7 \pm 0.5$	$16.5 \pm 0.3$	$\phi 99.5 \pm 0.5$	$\phi 13.6 \pm 0.2$	$2.8 \pm 0.2$	$1.9 \pm 0.2$

**Note:**

- 1) All Dimensions are in Millimeter
- 2) Quantity of Units per Reel is 3000
- 3) MSL level is level 3.

## X-ON Electronics

Largest Supplier of Electrical and Electronic Components

*Click to view similar products for [Battery Management](#) category:*

*Click to view products by [TMI](#) manufacturer:*

Other Similar products are found below :

[VN5R003HTR-E](#) [NCP1851BFCCT1G](#) [NCP1855FCCT1G](#) [FAN54063UCX](#) [LC05132C01NMTTGTG](#) [ISL78714ANZ](#) [CM1104-EH](#) [CM1104-DBB](#) [CM1104-MBB](#) [XC6801A421MR-G](#) [ISL95521BHRZ](#) [ISL95521BIRZ](#) [MP2639AGR-P](#) [S-82D1AAE-A8T2U7](#) [S-82D1AAA-A8T2U7](#) [S-8224ABA-I8T1U](#) [MC33772CTA1AE](#) [MC33772CTC0AE](#) [BQ28Z610DRZR-R1](#) [MCP73832-4ADI/MC](#) [MCP73832T-2DCIMC](#) [MCP73833T-AMIMF](#) [MCP73833T-AMI/UN](#) [MCP73838-NVI/MF](#) [MCP73213-A6BI/MF](#) [MCP73831-2ACI/MC](#) [MCP73831T-2ATIMC](#) [MCP73832-2ACI/MC](#) [MCP73832T-3ACIMC](#) [MCP73833T-FCI/MF](#) [MCP73853-IML](#) [BQ25895RTWR](#) [BQ29704DSER](#) [BQ78Z100DRZR](#) [ISL78610ANZ](#) [FAN5403UCX](#) [NCP367DPMUECTBG](#) [FAN54015BUCX](#) [MAX8934BETI+](#) [BQ24311DSGR](#) [BQ25100HYFPR](#) [BQ29707DSER](#) [MAX17048G+T10](#) [BQ24130RHRLR](#) [BQ25120AYFPR](#) [BQ29703DSER](#) [BQ771807DPJR](#) [BQ25120AYFPT](#) [MAX17055ETB+T](#) [MAX17710GB+T](#)