

USB Dedicated Charging Port Controller for Fast Charging Protocol and QC 2.0/3.0

FEATURES

- Supports HiSilicon Fast Charging Protocol (FCP) for Output Voltage and Current Communication Support Qualcomm Quick Charge2.0/3.0
- Class A: 3.6V up to 12V Output Voltage
- Automatic Selection FCP and QC2.0/3.0 Protocols
- Supports USB DCP Shorting D+ Line to D- Line per USB Battery Charging Specification Revision 1.2
- Meets Chinese Telecommunication Industrial Standard YD/T 1591-2009
- Supports USB DCP Applying 2.7V on D+ Line and 2.7V on D- Line
- Supports USB DCP Applying 1.2V on D+ and D- Lines
- SOT23-6 Package

APPLICATIONS

- Wall-Adapter, Smart Phones, Tablets, Netbooks
- Mobile / Tablet Power Bank
- Car Charger
- USB Power Output Ports

GENERAL DESCRIPTION

The TMI9290 is a fast charge protocol controller for HiSilicon Fast Charging Protocol (FCP) and Qualcomm Quick Charge2.0/3.0 (QC 2.0/3.0) USB interface. The device can fast charging FCP or QC 2.0/3.0 powered device (PD). The protocol feature monitors USB D+/D- data line voltage or D- data line transmission and automatically adjusts output voltage of power bank and wall adapter to optimize charge time.

TMI9290 can support not only USB BC compliant devices, but also Apple / Samsung / HUAWEI devices and automatically detects whether a connected powered device is QC 2.0/3.0 or FCP capable before enabling output voltage adjustment. If a PD not compliant to QC 2.0/3.0 or FCP is detected the TMI9290 disables output voltage adjustment to ensure safe operation with legacy 5 V only USB PDs.

The TMI9290 is available in a SOT23-6 package.

TYPICAL APPLICATION

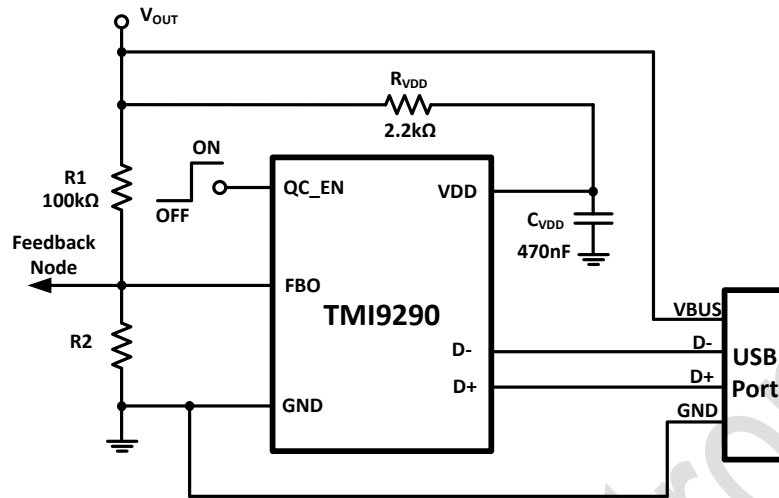

Figure 1. Basic Application Circuit

Output Voltage Lookup Table (QC2.0/3.0)

D+	D-	Output Voltage
0.6V	0.6V	12V
3.3V	0.6V	9V
0.6V	3.3V	Continuous mode
0.6V	High-Z	5V(Default)

ABSOLUTE MAXIMUM RATINGS

Parameter	Value	Unit
VDD Voltage Range	-0.3~6.5	V
DP, DM, FBO, QC_EN voltage	-0.3~6.5	V
Junction Temperature	-40~+150	°C
Storage Temperature Range	-50~150	°C
Lead Temperature	260	°C
Power Dissipation	0.5	W
Package Thermal Resistance	110	°C/W

Over operating free-air temperature range (unless otherwise noted)

PIN CONFIGURATION

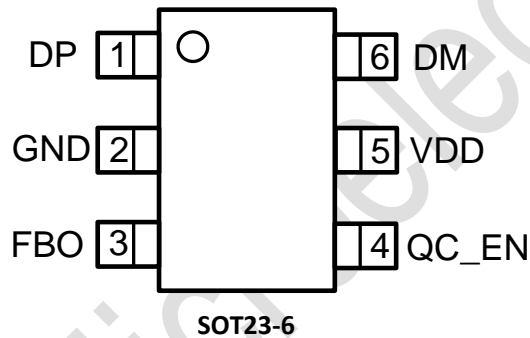

Top Mark: T23XXX (T23: Device Code, XXX: Inside Code)

Part Number	Package	Top Mark	Quantity/ Reel
TMI9290	SOT23-6	T23XXX	3000

TMI9290 devices are Pb-free and RoHS compliant.

PIN FUNCTIONS

Pin	Name	Function
1	DP	USB D+ data line
2	GND	Ground Pin
3	FBO	Current Sink/Source FB Node
4	QC_EN	QC Enable
5	VDD	Power Supply
6	DM	USB D- data line

ESD RATINGS

Items	Description	Value	Unit
V _{ESD}	Human Body Model for all pins	±8000	V

JEDEC specification JS-001

RECOMMENDED OPERATING CONDITIONS

Items	Description	Min	Max	Unit
Voltage Range	VDD	3.2	6.4	V
T _J	Operating Junction Temperature Range	-40	125	°C

ELECTRICAL CHARACTERISTICS
(V_{DD}=5V, T_A = 25°C, unless otherwise noted.)

Parameter	Symbol	Conditions	Min	Typ	Max	Unit
VDD Input Voltage Range	V _{DD}		3.2		6.4	V
Input UVLO Threshold	V _{UVLO}	V _{DD} fall	2.5		2.9	V
VDD Supply Current		V _{DD} =5V		200		μA
VDD Shunt Voltage	V _{DD} (SHUNT)	I _{VDD} =3mA	5.3	5.7	6.1	V
Data Detect Voltage	V _{DAT_REF}		0.25	0.325	0.4	V
Output Voltage selection reference	V _{SEL_REF}		1.8	2	2.2	V
D+ High Glitch Filter Time	T _{GLITCH_DP_H}			1250		ms
D- Low Glitch Filter Time	T _{GLITCH_DM_L}			1		ms
Output Voltage Glitch Filter Time	T _{GLITCH_CHANGE}			40		ms
D- Pull-Down Resistance	R _{DM}			20		kΩ
Continuous Mode Glitch Filter Time	T _{GLITCH_CONT_CHANGE}			150		μs
D+ Leakage Resistance	R _{DP}			500		kΩ
Switch SW1 on-resistance	R _{DS_ON}				40	Ω
Up/Down Current Step	I _{UP/IDOWN}			2		μA
D+ _1.2V/D- _1.2V line output voltage	V _{1.2V}		1.08	1.2	1.32	V
D+ _1.2V/D- _1.2V line output Impedance				100		kΩ
D+ _2.7V/D- _2.7V line output voltage	V _{2.7V}		2.56	2.7	2.84	V
D+ _2.7V/D- _2.7V line output Impedance				33.6		kΩ
D- FCP Tx Valid Output High	V _{TX_VOH}		2.55		3.6	V
D- FCP Tx Valid Output Low	V _{TX_VOL}				0.3	V
D- FCP Rx Valid Output High	V _{RX_VOH}		1.4		3.6	V
D- FCP Rx Valid Output Low	V _{RX_VOL}				1	V
D- Output Pull-Low Resistance (FCP)	R _{PD}			500		kΩ
Unit Interval for FCP PHY communication	UI	F _{CLK} =125kHz	144	160	176	μs

FUNCTIONAL DESCRIPTION

The TMI9290 is a USB high voltage dedicated charging port interface IC for Qualcomm Quick Charge 2.0/3.0 class A, HiSilicon FCP specification.

The TMI9290 can fast charge most of the handheld devices. It can be like the original charging adapter.

The TMI9290 can support BC1.2, Apple, Samsung and HUAWEI devices. It also supports full output voltage range of QC 3.0 Class A (3.6V to 12V) or QC 2.0 Class A (5V, 9V, 12V)

Quick Charge 2.0/3.0 Interface

Power up D+/D- is supply 2.7V to Apple Device and then supply D+ short to D- into BC1.2. Set the output voltage level 5V. If D+ continuous above 0.325V and keep 1.25 seconds TMI9290 can automatic choose into Quick Charge 2.0/3.0, FCP operation mode.

When $V_{DAT(REF)} < D+ < V_{SEL_REF}$ and $D- > V_{SEL_REF}$, the TMI9290 enter continuous mode. Each step of D+ from 1V to 3V Pulse-width during 200us cause current sink $2\mu A$ by FBO. The maximum output sink current is $70\mu A$ for output voltage reach to 12V. Each step of D- from 3V to 1V Pulse-width during $200\mu s$ cause current source $2\mu A$ by FBO. The minimum output source current is $14\mu A$ for output voltage reach to 3.6V.

If power device without QC 2.0 the device will keep output voltage level 5V guarantee safe operation for only 5V USB power device. When USB cable unplug the D+ voltage $< V_{DAT(REF)}$ and output voltage recovery default mode 5V.

Shunt Regulator

The wide power supply output voltage through external resistor from R_{VDD} to VDD. The internal clamp VDD pin at 5.7V. Recommend $R_{VDD} = 2.2k\Omega$ and $C_{VDD} = 470nF$.

QC_EN Function

QC_EN pin disables QC 2.0/3.0 and FCP function by connected to GND, Otherwise, it enables function by connected to VDD or floating. QC_EN signal need to be ready before TMI9290 starts detection. When TMI9290 already access QC2.0/3.0 or FCP mode, the mode won't be changed by setting QC_EN pin signal (High to Low).

FUNCTIONAL BLOCK DIAGRAM

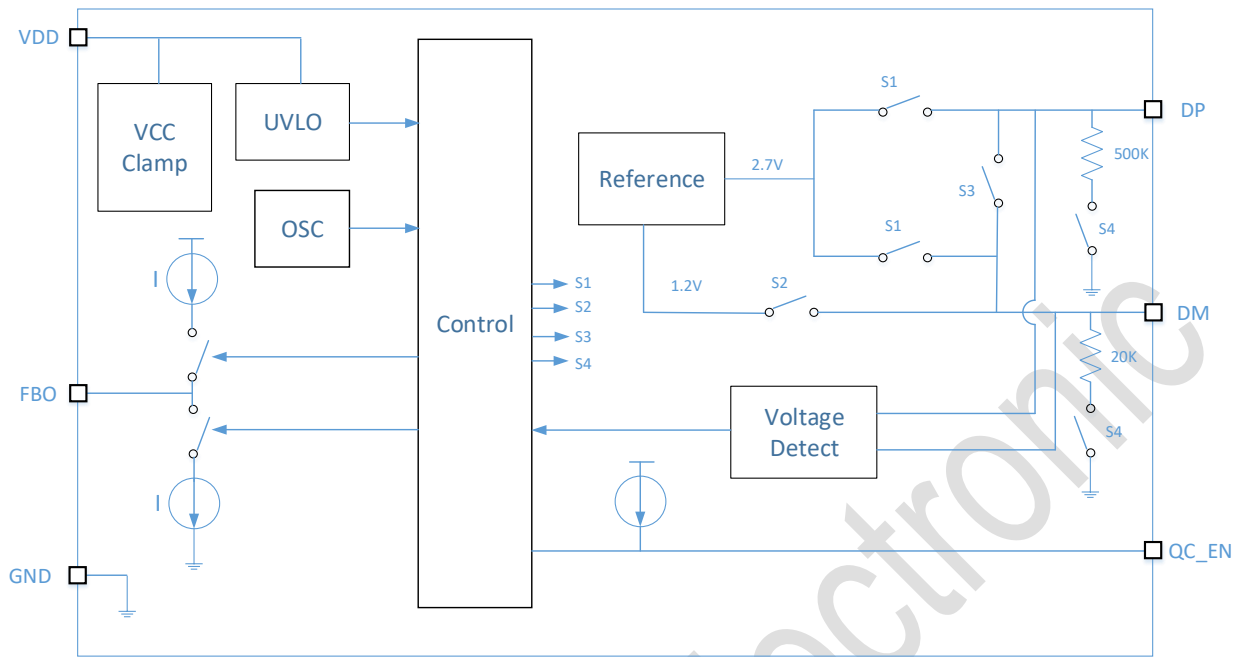
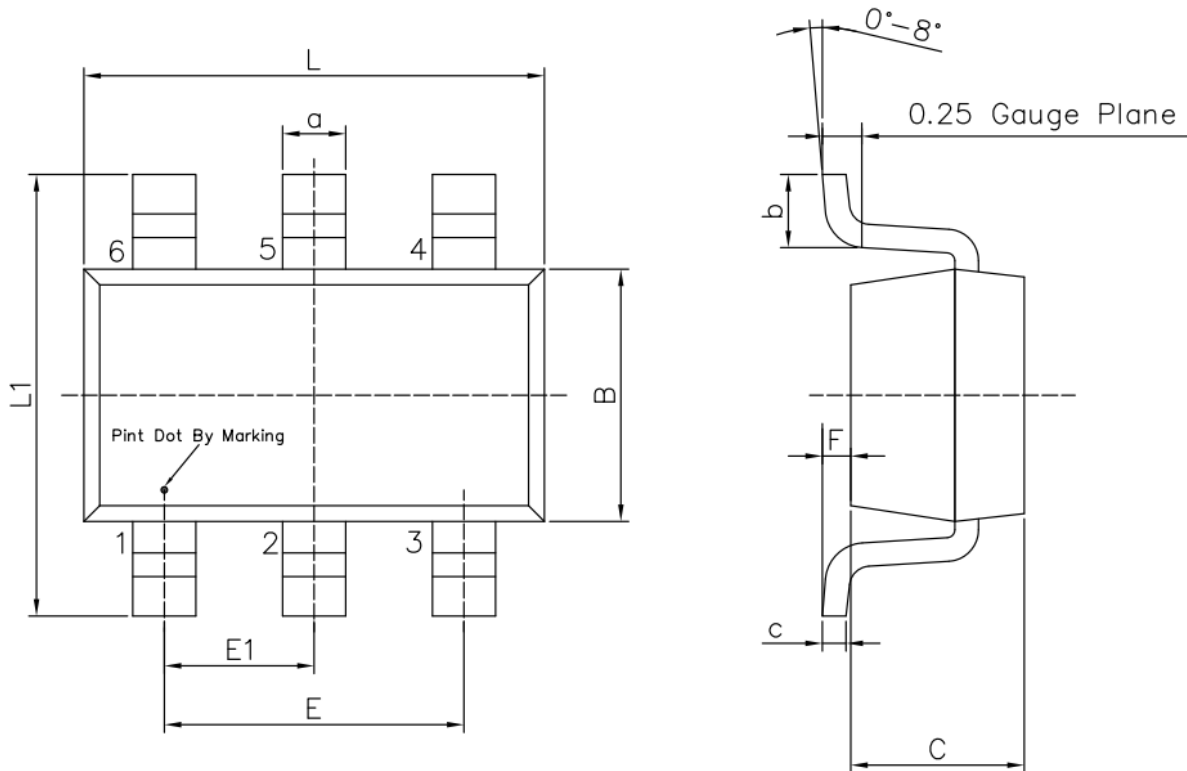

Figure2. TMI9290 Block Diagram

PACKAGE INFORMATION

SOT23-6



Unit: mm

Symbol	Dimensions In Millimeters		Symbol	Dimensions In Millimeters	
	Min	Max		Min	Max
L	2.82	3.02	E1	0.85	1.05
B	1.50	1.70	a	0.35	0.50
C	0.90	1.30	c	0.10	0.20
L1	2.60	3.00	b	0.35	0.55
E	1.80	2.00	F	0	0.15

Note:

- 1) All dimensions are in millimeters.
- 2) Package length does not include mold flash, protrusion or gate burr.
- 3) Package width does not include inter lead flash or protrusion.
- 4) Lead popularity (bottom of leads after forming) shall be 0.10 millimeters max.
- 5) Pin 1 is lower left pin when reading top mark from left to right.

TAPE AND REEL INFORMATION

TAPE DIMENSIONS: SOT23-6

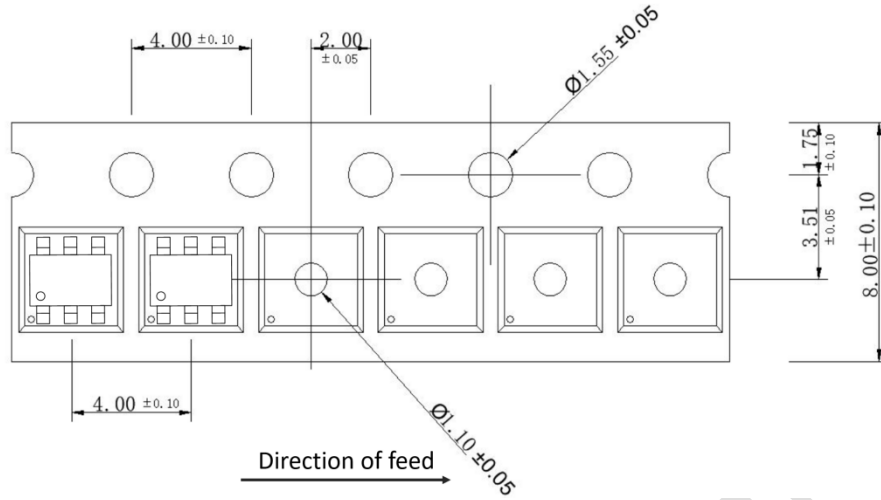

REEL DIMENSIONS: SOT23-6

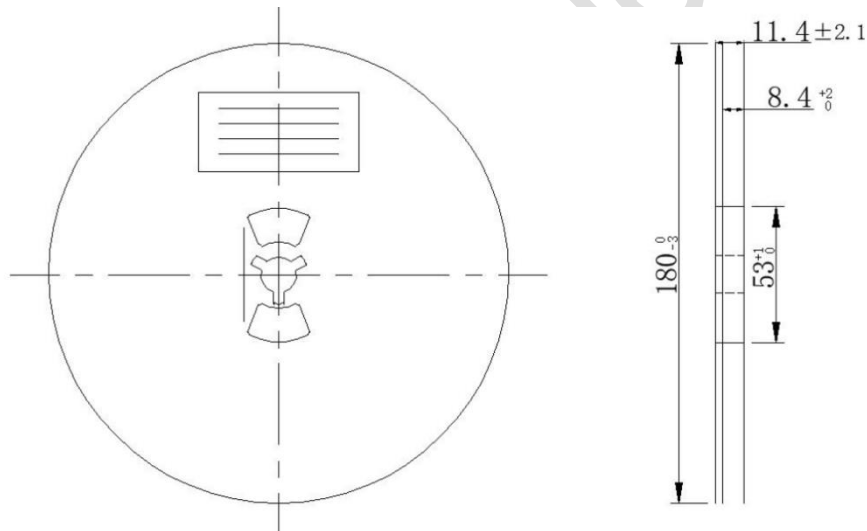

Note:

- 1) All Dimensions are in Millimeter
- 2) Quantity of Units per Reel is 3000
- 3) MSL level is level 3.

X-ON Electronics

Largest Supplier of Electrical and Electronic Components

Click to view similar products for [Battery Management](#) category:

Click to view products by [TMI](#) manufacturer:

Other Similar products are found below :

[VN5R003HTR-E](#) [NCP1851BFCCT1G](#) [NCP1855FCCT1G](#) [FAN54063UCX](#) [LC05132C01NMTTGTG](#) [ISL78714ANZ](#) [CM1104-EH](#) [CM1104-DBB](#) [CM1104-MBB](#) [XC6801A421MR-G](#) [ISL95521BHRZ](#) [ISL95521BIRZ](#) [MP2639AGR-P](#) [S-82D1AAE-A8T2U7](#) [S-82D1AAA-A8T2U7](#) [S-8224ABA-I8T1U](#) [MC33772CTC0AE](#) [BQ28Z610DRZR-R1](#) [MCP73832-4ADI/MC](#) [MCP73832T-2DCIMC](#) [MCP73833T-AMIMF](#) [MCP73833T-AMI/UN](#) [MCP73838-NVI/MF](#) [MCP73213-A6BI/MF](#) [MCP73831-2ACI/MC](#) [MCP73831T-2ATIMC](#) [MCP73832-2ACI/MC](#) [MCP73832T-3ACIMC](#) [MCP73833T-FCI/MF](#) [MCP73853-IML](#) [BQ25895RTWR](#) [BQ29704DSER](#) [BQ78Z100DRZR](#) [ISL78610ANZ](#) [FAN5403UCX](#) [NCP367DPMUECTBG](#) [FAN54015BUCX](#) [MAX8934BETI+](#) [BQ24311DSGR](#) [BQ25100HYFPR](#) [BQ29707DSER](#) [MAX17048G+T10](#) [BQ24130RHRLR](#) [BQ25120AYFPR](#) [BQ29703DSER](#) [BQ771807DPJR](#) [BQ25120AYFPT](#) [MAX17055ETB+T](#) [MAX17710GB+T](#) [MAX14634EWC+](#)