

General Description

This Power MOSFET is produced using advanced self-aligned planar technology. This advanced technology has been especially tailored to minimize on-state resistance, provide superior switching performance, and withstand high energy pulse in the avalanche and commutation mode.

These devices can be used in various power switching circuit for system miniaturization and higher efficiency.

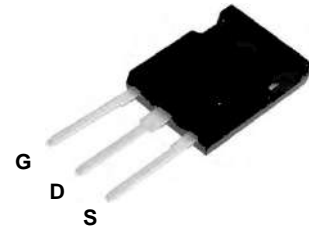

TO-247-3

Features

- 3A, 1500V, $R_{DS(on)}$ typ. = 5Ω @ $V_{GS} = 10V$ $I_d = 1.5A$
- Low gate charge (typical 9.3nC)
- Low gate charge (typical 2.4pf)
- Fast switching
- 100% avalanche tested

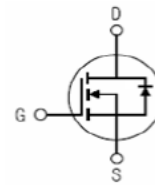
Inner Equivalent Principium Chart

Absolute Maximum Ratings $T_c = 25^\circ C$ unless otherwise noted

Symbol	Parameter	CIM3N150D3	Units
V_{DSS}	Drain – Source Voltage	1500	V
I_D	Drain Current	Continuous ($T_c = 25^\circ C$)	3
		Continuous ($T_c = 100^\circ C$)	1.8
I_{DM}	Drain Current - Pulsed (Note 1)	12	A
V_{GSS}	Gate – Source Voltage	± 30	V
EAS	Single Pulsed Avalanche Energy (Note 2)	225	mJ
dv/dt	Peak Diode Recovery dv/dt (Note 3)	5	V/ns
P_D	Power Dissipation ($T_c = 25^\circ C$)	83	W
T_J, T_{STG}	Operating and Storage Temperature Range	-55 to +150	$^\circ C$
T_L	Maximum lead temperature for soldering purposes 1/8" from case for 5 seconds	300	$^\circ C$

*Drain current limited by maximum junction temperature.

Thermal characteristics

Symbol	Parameter	CIM3N150D3	Units
$R_{\theta JC}$	Thermal Resistance, Junction-to-Case	1.5	$^\circ C/W$
$R_{\theta JA}$	Thermal Resistance, Junction-to-Ambient	50	$^\circ C/W$

Electrical Characteristics $T_c = 25^\circ C$ unless otherwise noted

Symbol	Parameter	Test Conditions	Min	Typ	Max	Units
--------	-----------	-----------------	-----	-----	-----	-------



Off Characteristics						
BV _{DSS}	Drain – Source Breakdown Voltage	V _{GS} = 0 V, I _D = 250 uA	1500	--	--	V
$\Delta BV_{DSS}/\Delta T_J$	Breakdown Voltage Temperature Coefficient	I _D = 250 uA, Referenced to 25°C	--	1.3	--	V/°C
I _{DSS}	Zero Gate Voltage Drain Current	V _{DS} = 1500 V, V _{GS} = 0 V	--	--	25	uA
		V _{DS} = 1200 V, T _C = 125 °C	--	--	500	uA
I _{GSSF}	Gate-Body Leakage Current, Forward	V _{GS} = 30 V, V _{DS} = 0 V	--	--	100	nA
I _{GSSR}	Gate-Body Leakage Current, Reverse	V _{GS} = -30 V, V _{DS} = 0 V	--	--	-100	nA
On Characteristics						
V _{GS(th)}	Gate Threshold Voltage	V _{DS} = V _{GS} , I _D = 250 uA	3.0	--	5.0	V
R _{DS(on)}	Static Drain-Source on-Resistance	V _{GS} = 10 V, I _D = 1.5A	--	5	8	Ω
g _{FS}	Forward Transconductance	V _{DS} = 30 V, I _D = 1.5 A (Note 4)	--	4.5	--	S
Dynamic Characteristics						
C _{iss}	Input Capacitance	V _{DS} = 25 V, V _{GS} = 0 V, f = 1.0 MHz	--	1938	--	pF
C _{oss}	Output Capacitance		--	104	--	pF
C _{rss}	Reverse Transfer Capacitance		--	2.4	--	pF
R _g	Gate resistance	F = 1.0 MHz		3.5		Ω
Switching Characteristics						
t _{d(on)}	Turn-On Delay Time	V _{DS} = 750 V, I _D = 3.0 A, R _G = 10Ω, V _{GS} = 10 V (Note 4,5)	--	34	--	ns
t _r	Turn-On Rise Time		--	17	--	ns
t _{d(off)}	Turn-Off Delay Time		--	56	--	ns
t _f	Turn-Off Fall Time		--	27	--	ns
Q _g	Total Gate Charge	V _{DS} = 750 V, I _D = 3.0 A V _{GS} = 10 V (Note 4,5)	--	9.3	--	nC
Q _{gs}	Gate-Source Charge		--	15	--	nC
Q _{gd}	Gate-Drain Charge		--	5.3	--	nC
Drain – Source Diode Characteristics and Maximum Ratings						
I _S	Maximum Continuous Drain-Source Diode Forward Current		--	--	3	A
I _{SM}	Maximum Pulsed Drain-Source Diode Forward Current		--	--	12	A
V _{SD}	Drain-Source Diode Forward Voltage	V _{GS} = 0 V, I _S = 3.0 A	--	--	1.5	V
t _{rr}	Reverse Recovery Time	V _{GS} = 0 V, I _S = 3.0 A	--	302	--	ns
Q _{rr}	Reverse Recovery Charge	dI _F /dt = 100 A/us (Note 4)	--	10	--	uC

Notes:

1. Repetitive Rating : Pulsed width limited by maximum junction temperature
2. L = 10.0mH , I_{AS} = 6.7A, R_G = 25Ω, Starting T_J = 25°C
3. I_{SD} ≤ 3.0A, di/dt ≤ 100A/us, V_{DD} ≤ BV_{DSS}, Starting T_J = 25°C
4. Pulsed Test : Pulsed width ≤ 300us, Duty cycle ≤ 2%
5. Essentially independent of operating temperature

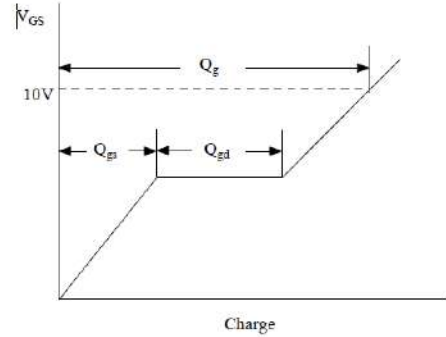
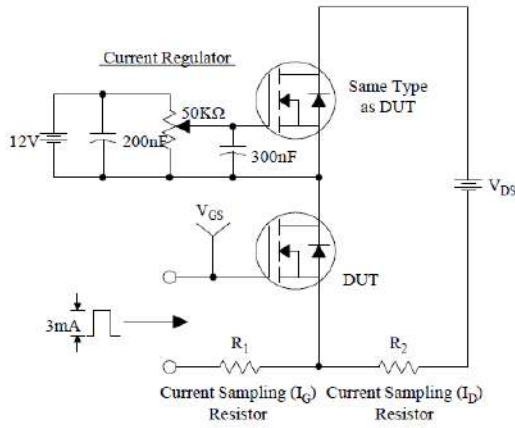

Gate Charge Test Circuit & Waveform

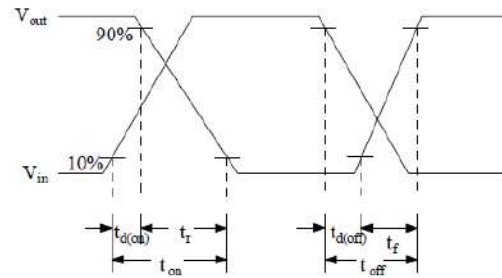
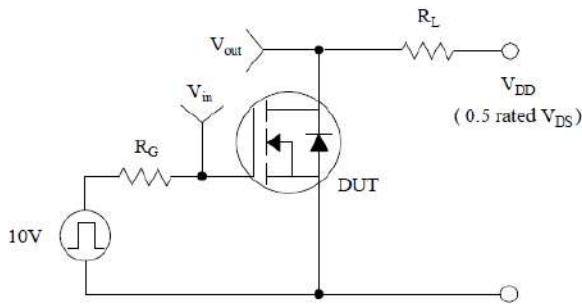

Resistive Switching Test Circuit & Waveforms

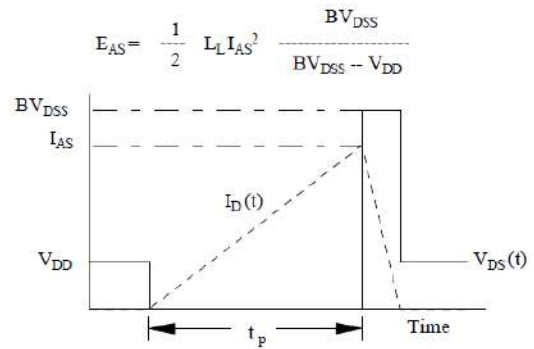
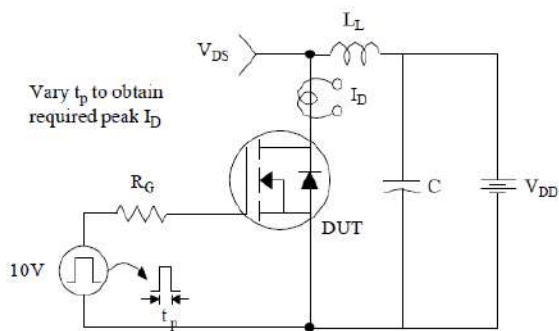

$$E_{AS} = \frac{1}{2} L_L I_{AS}^2 \frac{BV_{DSS}}{BV_{DSS} - V_{DD}}$$

Unclamped Inductive Switching Test Circuit & Waveforms

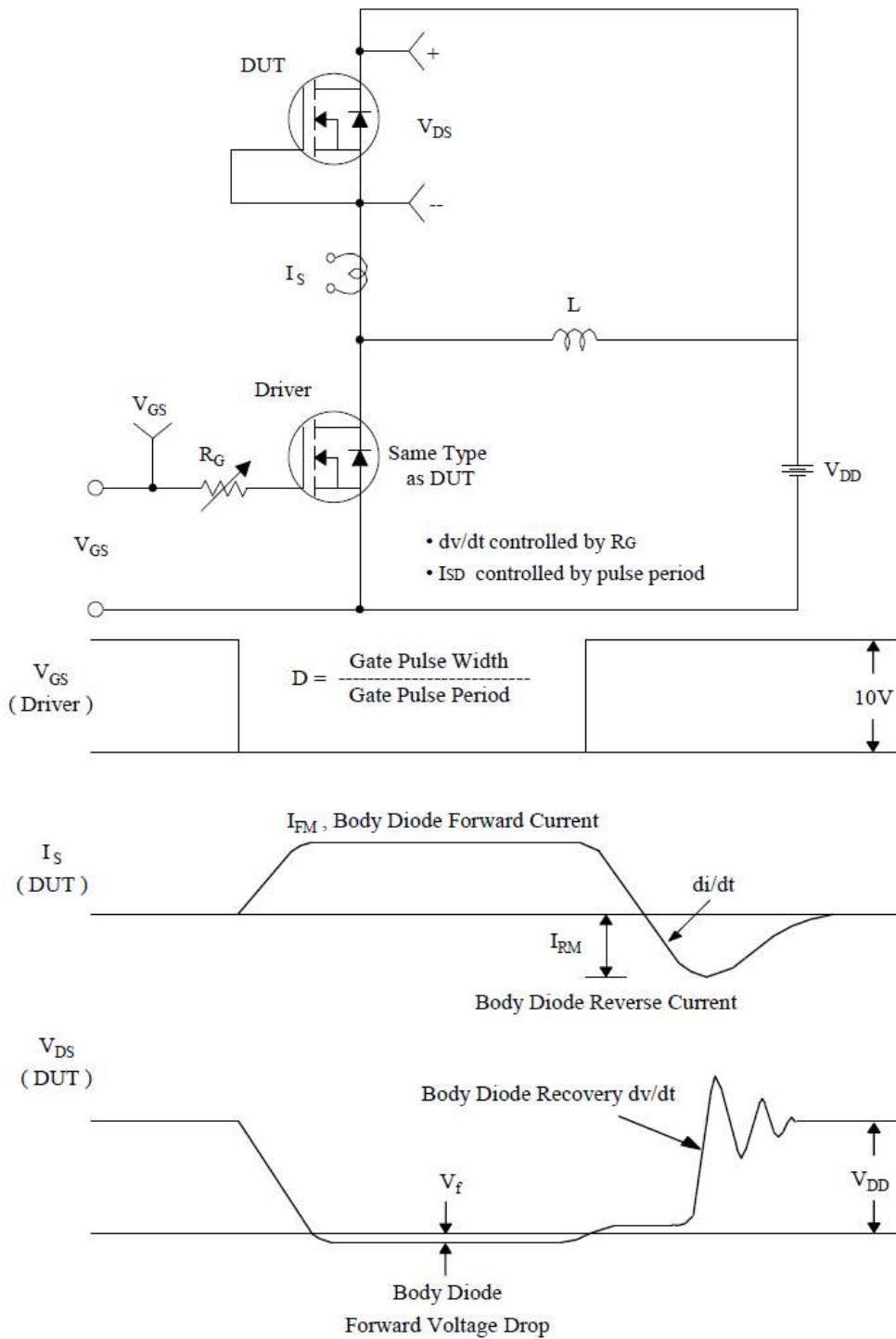

Peak Diode Recovery dv/dt Test Circuit & Waveforms

Package Dimensions

Package TO-247-3

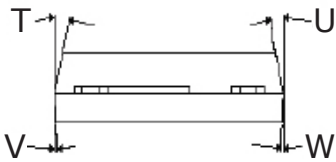
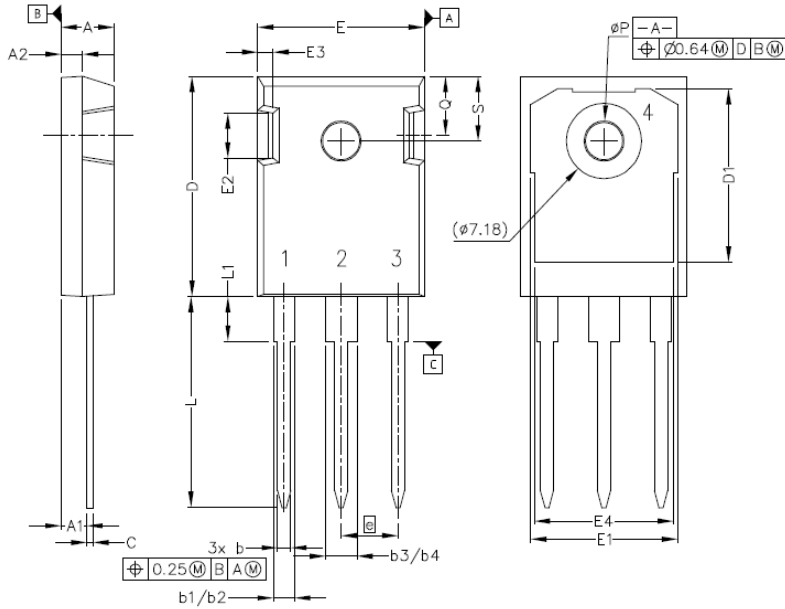

Pinout Information:

- Pin 1 = Gate
- Pin 2, 4 = Drain
- Pin 3 = Source

POS	Inches		Millimeters	
	Min	Max	Min	Max
A	.190	.205	4.83	5.21
A1	.090	.100	2.29	2.54
A2	.075	.085	1.91	2.16
b	.042	.052	1.07	1.33
b1	.075	.095	1.91	2.41
b2	.075	.085	1.91	2.16
b3	.113	.133	2.87	3.38
b4	.113	.123	2.87	3.13
c	.022	.027	0.55	0.68
D	.819	.831	20.80	21.10
D1	.640	.695	16.25	17.65
D2	.037	.049	0.95	1.25
E	.620	.635	15.75	16.13
E1	.516	.557	13.10	14.15
E2	.145	.201	3.68	5.10
E3	.039	.075	1.00	1.90
E4	.487	.529	12.38	13.43
e	.214 BSC		5.44 BSC	
N	3		3	
L	.780	.800	19.81	20.32
L1	.161	.173	4.10	4.40
ØP	.138	.144	3.51	3.65
Q	.216	.236	5.49	6.00
S	.238	.248	6.04	6.30
T	9°	11°	9°	11°
U	9°	11°	9°	11°
V	2°	8°	2°	8°
W	2°	8°	2°	8°

X-ON Electronics

Largest Supplier of Electrical and Electronic Components

Click to view similar products for [MOSFET](#) category:

Click to view products by [Tokmas](#) manufacturer:

Other Similar products are found below :

[IRFD120](#) [JANTX2N5237](#) [2SK2267\(Q\)](#) [BUK455-60A/B](#) [TK100A10N1,S4X\(S](#) [MIC4420CM-TR](#) [VN1206L](#) [NDP4060](#) [SI4482DY](#)
[IRS2092STRPBF-EL](#) [IPS70R2K0CEAKMA1](#) [TK31J60W5,S1VQ\(O](#) [TK31J60W,S1VQ\(O](#) [TK16J60W,S1VQ\(O](#) [2SK2614\(TE16L1,Q\)](#)
[DMN1017UCP3-7](#) [EFC2J004NUZTDG](#) [P85W28HP2F-7071](#) [DMN1053UCP4-7](#) [NTE2384](#) [DMC2700UDMQ-7](#) [DMN2080UCB4-7](#)
[DMN61D9UWQ-13](#) [US6M2GTR](#) [DMN31D5UDJ-7](#) [DMP22D4UFO-7B](#) [IPS60R3K4CEAKMA1](#) [DMN1006UCA6-7](#) [DMN16M9UCA6-7](#)
[STF5N65M6](#) [IRF40H233XTMA1](#) [STU5N65M6](#) [DMN6022SSD-13](#) [DMN13M9UCA6-7](#) [DMTH10H4M6SPS-13](#) [IPS60R360PFD7SAKMA1](#)
[DMN2990UFB-7B](#) [SSM3K35CT,L3F](#) [IPLK60R1K0PFD7ATMA1](#) [2N7002W-G](#) [MCAC30N06Y-TP](#) [IPWS65R035CFD7AXKSA1](#)
[MCQ7328-TP](#) [SSM3J143TU,LXHF](#) [DMN12M3UCA6-7](#) [PJMF280N65E1_T0_00201](#) [PJMF380N65E1_T0_00201](#)
[PJMF280N60E1_T0_00201](#) [PJMF600N65E1_T0_00201](#) [PJMF900N65E1_T0_00201](#)