

Features:

- $R_{DS(ON)} < 14m\Omega$ @ $V_{GS}=10V$ (Typ11m Ω)
- High density cell design for ultra low R_{dson}
- Fully characterized avalanche voltage and current
- Excellent package for good heat dissipation

V_{DSS}	-30	V
I_D	-12	A
P_D	3.0	W
$R_{DS(ON)type}$	11	m Ω

Applications:

- Power switching application
- Hard switched and high frequency circuits
- Uninterruptible power supply

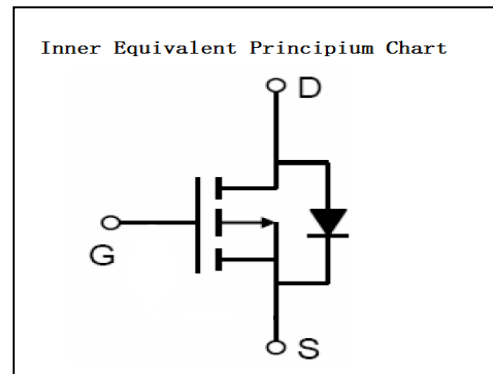
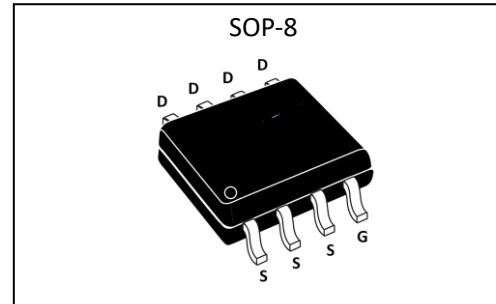

Absolute ($T_c = 25^\circ C$ unless otherwise specified) :

Symbol	Parameter	Rating	Units
V_{DSS}	Drain-to-Source Voltage	-30	V
I_D	Continuous Drain Current	-12	A
	Continuous Drain Current $T_C = 70^\circ C$	-10	A
I_{DM}^{a1}	Pulsed Drain Current	-48	A
V_{GS}	Gate-to-Source Voltage	± 20	V
E_{as}^{a5}	$L=0.5mH$	140	mJ
dv/dt^{a3}	Peak Diode Recovery dv/dt	5.0	V/ns
P_D	Power Dissipation	3.0	W
T_J, T_{stg}	Operating Junction and Storage Temperature Range	150, -55 to 150	$^\circ C$
T_L	Maximum Temperature for Soldering	300	$^\circ C$

Electrical Characteristics (Tc= 25°C unless otherwise specified) :

OFF Characteristics						
Symbol	Parameter	Test Conditions	Rating			Units
			Min.	Typ.	Max.	
V _{DSS}	Drain to Source Breakdown Voltage	V _{GS} =0V, I _D =250μA	-30	--	--	V
I _{DSS}	Drain to Source Leakage Current	V _{DS} =-30V, V _{GS} = 0V, T _a =25°C	--	--	1.0	μA
I _{GSS(F)}	Gate to Source Forward Leakage	V _{GS} = +20V	--	--	0.1	μA
I _{GSS(R)}	Gate to Source Reverse Leakage	V _{GS} =-20V	--	--	-0.1	μA

ON Characteristics ^{a3}						
Symbol	Parameter	Test Conditions	Rating			Units
			Min.	Typ.	Max.	
R _{DS(ON)}	Drain-to-Source On-Resistance	V _{GS} =-10V, I _D =-10A	--	11	14	mΩ
V _{GS(TH)}	Gate Threshold Voltage	V _{DS} =V _{GS} , I _D =250μA	-1	--	-3.0	V

Pulse width tp ≤ 380μs, δ ≤ 2%

Dynamic Characteristics ^{a4}						
Symbol	Parameter	Test Conditions	Rating			Units
			Min.	Typ.	Max.	
g _{fs}	Forward Transconductance	V _{DS} =-5V, I _D =-10A	20	--	--	S
C _{iss}	Input Capacitance	V _{GS} =0V, V _{DS} =-15V f=1.0MHz	--	1800	--	pF
C _{oss}	Output Capacitance		--	220	--	
C _{rss}	Reverse Transfer Capacitance		--	180	--	

Resistive Switching Characteristics ^{a4}						
Symbol	Parameter	Test Conditions	Rating			Units
			Min.	Typ.	Max.	
t _{d(ON)}	Turn-on Delay Time	V _{DD} =-15V, I _D =-10A V _{GS} =-10V, R _G =3Ω	--	10	--	ns
t _r	Rise Time		--	9	--	
t _{d(OFF)}	Turn-Off Delay Time		--	26	--	
t _f	Fall Time		--	11	--	
Q _g	Total Gate Charge	V _{DD} =-15V, I _D =-10A V _{GS} =-10V	--	25	--	nC
Q _{gs}	Gate to Source Charge		--	4.0	--	
Q _{gd}	Gate to Drain ("Miller")Charge		--	6	--	

Source-Drain Diode Characteristics						
Symbol	Parameter	Test Conditions	Rating			Units
			Min.	Typ.	Max.	
I_S	Continuous Source Current ^{a2} (Body Diode)		--	--	-12	A
V_{SD}	Diode Forward Voltage ^{a3}	$I_S = -12A, V_{GS} = 0V$	--	--	-1.5	V
t_{rr}	Reverse Recovery Time	$I_S = -12A, T_j = 25^\circ C$ $di_F/dt = 100A/\mu s,$ $V_{GS} = 0V$	--	38	--	ns
Q_{rr}	Reverse Recovery Charge		--	30	--	nC

Symbol	Parameter	Typ.	Units
$R_{\theta JC}$	Junction-to-Case ^{a2}	41.7	°C/W

^{a1}: Repetitive Rating: Pulse width limited by maximum junction temperature.

^{a2}: Surface Mounted on FR4 Board, $t \leq 10\text{sec}$.

^{a3}: Pulse Test: Pulse Width $\leq 300\mu s$, Duty Cycle $\leq 2\%$.

^{a4}: Guaranteed by design, not subject to production

^{a5}: $T_J = 25^\circ C, V_{DD} = 15V, V_G = 10V, L = 0.5\text{Mh}$

Typical Electrical and Thermal Characteristics

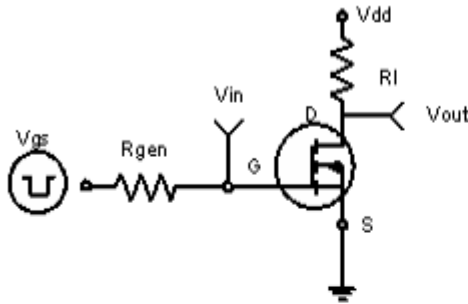

Figure 1: Switching Test Circuit

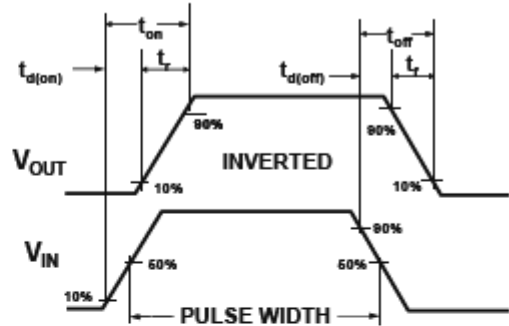

Figure 2: Switching Waveforms

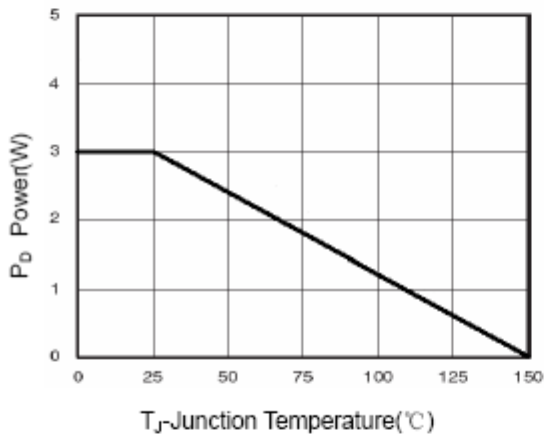

Figure 3 Power Dissipation

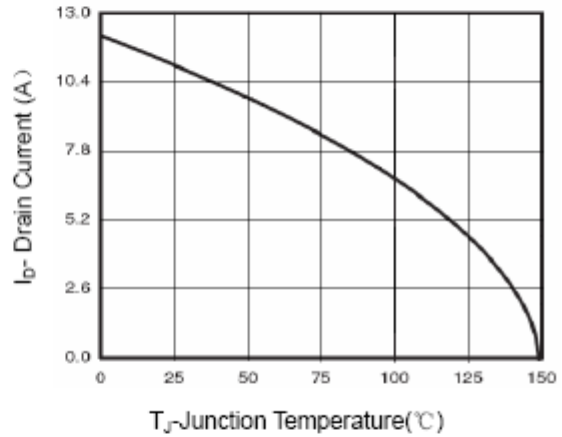

Figure 4 Drain Current

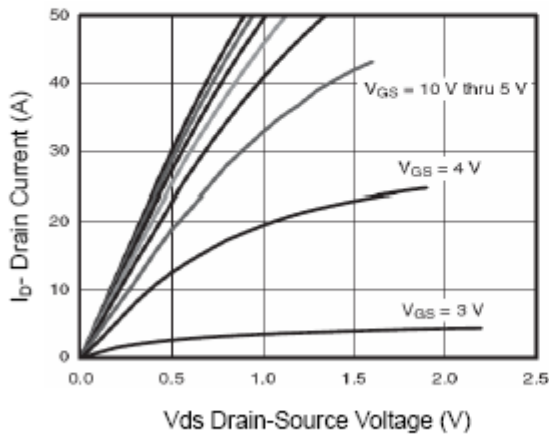

Figure 5 Output Characteristics

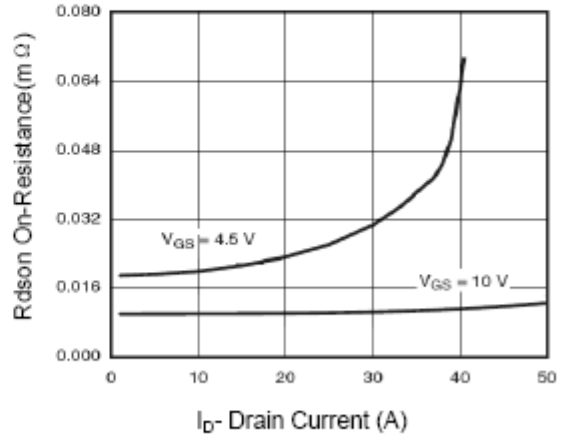

Figure 6 Drain-Source On-Resistance

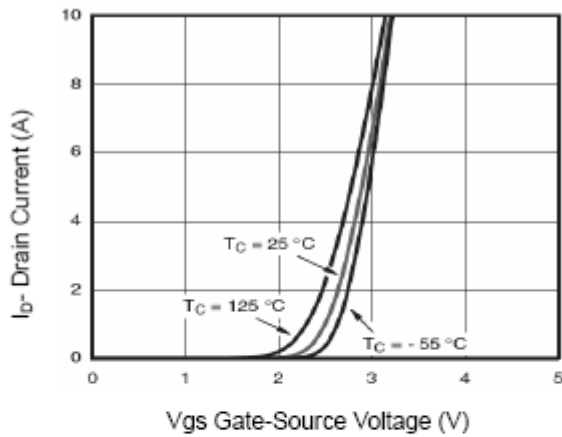

Figure 7 Transfer Characteristics

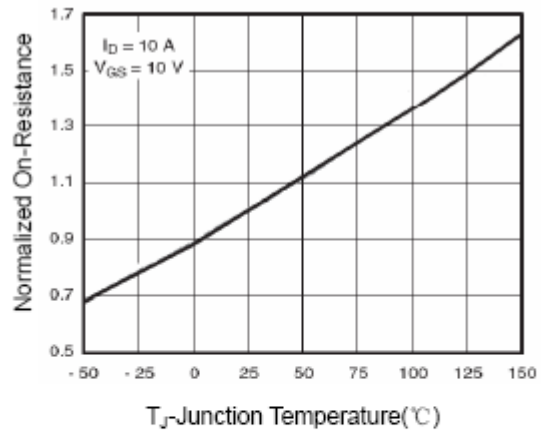

Figure 8 Drain-Source On-Resistance

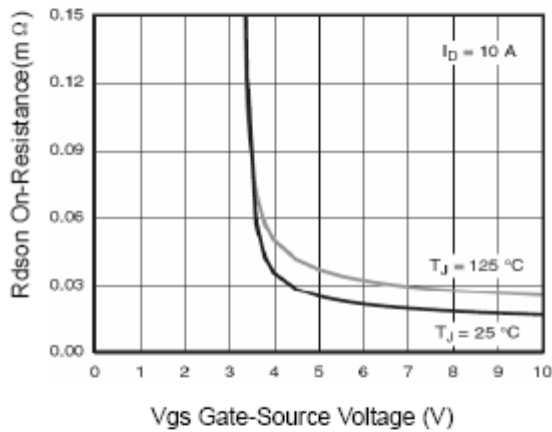

Figure 9 Rdson vs Vgs

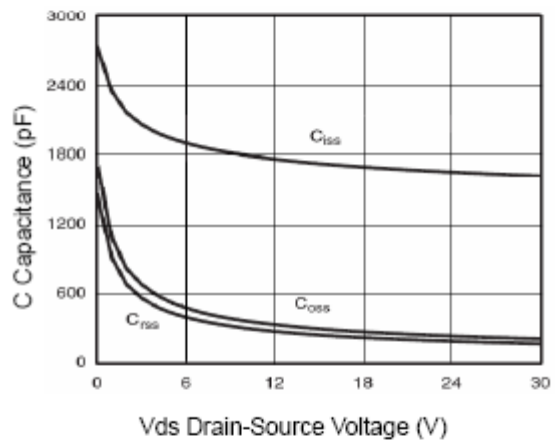

Figure 10 Capacitance vs Vds

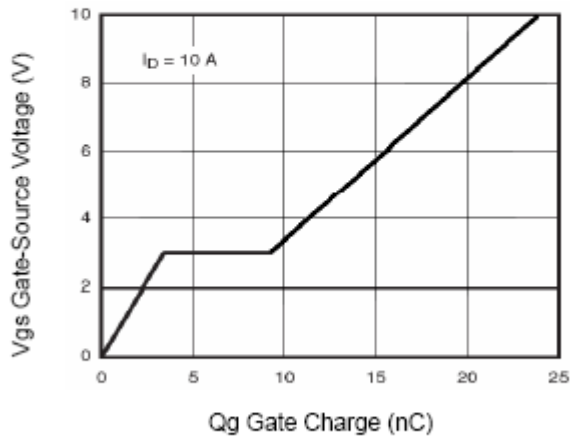

Figure 11 Gate Charge

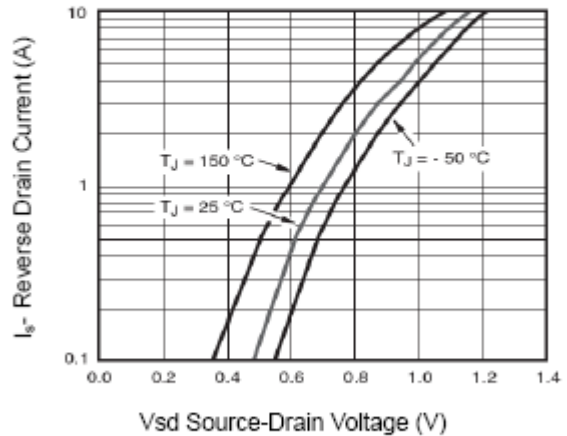

Figure 12 Source- Drain Diode Forward

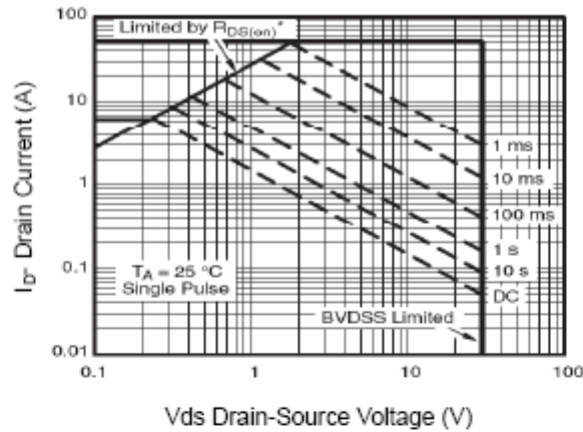

Figure 13 Safe Operation Area

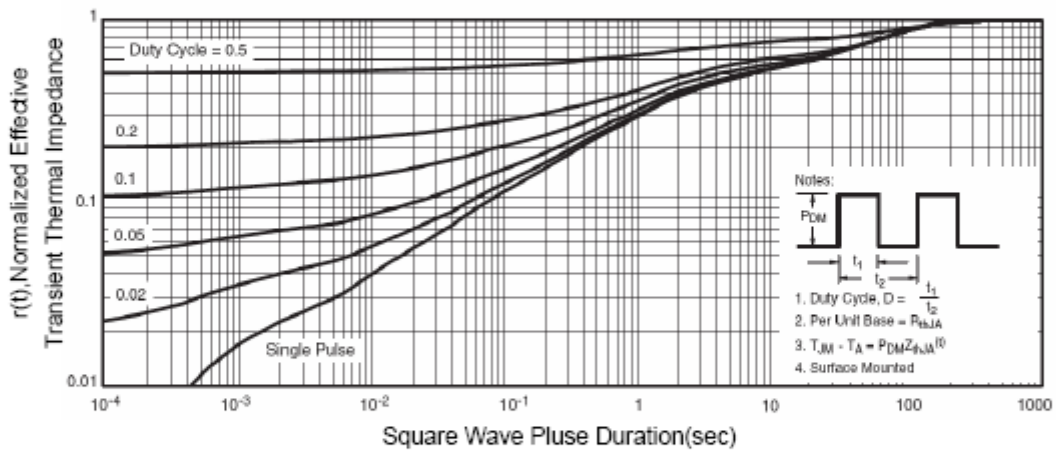

Figure 14 Normalized Maximum Transient Thermal Impedance

X-ON Electronics

Largest Supplier of Electrical and Electronic Components

Click to view similar products for [MOSFET](#) category:

Click to view products by [Tokmas](#) manufacturer:

Other Similar products are found below :

[IRFD120](#) [JANTX2N5237](#) [BUK455-60A/B](#) [MIC4420CM-TR](#) [VN1206L](#) [NDP4060](#) [SI4482DY](#) [IPS70R2K0CEAKMA1](#) [SQD23N06-31L-GE3](#)
[TK16J60W,S1VQ\(O](#) [2SK2614\(TE16L1,Q\)](#) [DMN1017UCP3-7](#) [DMN1053UCP4-7](#) [SQJ469EP-T1-GE3](#) [NTE2384](#) [DMC2700UDMQ-7](#)
[DMN2080UCB4-7](#) [DMN61D9UWQ-13](#) [US6M2GTR](#) [DMN31D5UDJ-7](#) [DMP22D4UFO-7B](#) [DMN1006UCA6-7](#) [DMN16M9UCA6-7](#)
[STF5N65M6](#) [IRF40H233XTMA1](#) [STU5N65M6](#) [DMN6022SSD-13](#) [DMN13M9UCA6-7](#) [DMTH10H4M6SPS-13](#) [DMN2990UFB-7B](#)
[IPB80P04P405ATMA2](#) [2N7002W-G](#) [MCAC30N06Y-TP](#) [MCQ7328-TP](#) [NTMC083NP10M5L](#) [BXP7N65D](#) [BXP4N65F](#) [AOL1454G](#)
[WMJ80N60C4](#) [BXP2N20L](#) [BXP2N65D](#) [BXT1150N10J](#) [BXT1700P06M](#) [TSM60NB380CP](#) [ROG](#) [RQ7L055BGTGR](#) [DMNH15H110SK3-13](#)
[SLF10N65ABV2](#) [BSO203SP](#) [BSO211P](#) [IPA60R230P6](#)