

Features

- Single-Supply Operation from +2.1V ~ +5.5V
- Rail-to-Rail Input / Output
- Gain-Bandwidth Product: 11MHz (Typ)
- Low Input Bias Current: 1pA (Typ)
- Low Offset Voltage: 3.5mV (Max)
- High Slew Rate: 9V/μs
- Settling Time to 0.1% with 2V Step: 0.3μs
- Low Noise : 8nV/√Hz @10kHz
- Quiescent Current: 1.1mA per Amplifier (Typ)
- Operating Temperature: -40°C ~ +125°C

Applications

- Sensors
- Active Filters
- Cellular and Cordless Phones
- Laptops and PDAs
- Audio
- Handheld Test Equipment
- Battery-Powered Instrumentation
- A/D Converters

Pin Configuration

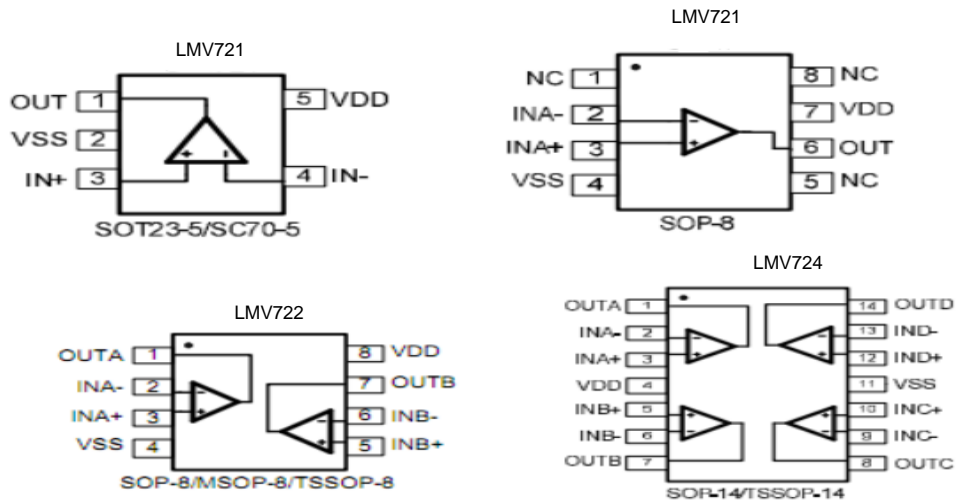

Figure 1. Pin Assignment Diagram

Absolute Maximum Ratings

Condition	Min	Max
Power Supply Voltage (V_{DD} to V_{SS})	-0.5V	+7.5V
Analog Input Voltage ($IN+$ or $IN-$)	$V_{SS}-0.5V$	$V_{DD}+0.5V$
PDB Input Voltage	$V_{SS}-0.5V$	+7V
Operating Temperature Range	-40°C	+125°C
Junction Temperature	+160°C	
Storage Temperature Range	-55°C	+150°C
Lead Temperature (soldering, 10sec)	+260°C	
Package Thermal Resistance ($T_A=+25^\circ\text{C}$)		
SOP-8, θ_{JA}	125°C/W	
MSOP-8, θ_{JA}	216°C/W	
SOT23-5, θ_{JA}	190°C/W	
SOT23-6, θ_{JA}	190°C/W	
SC70-5, θ_{JA}	333°C/W	
ESD Susceptibility		
HBM	8KV	
MM	400V	

Note: Stress greater than those listed under Absolute Maximum Ratings may cause permanent damage to the device. This is a stress rating only and functional operation of the device at these or any other conditions outside those indicated in the operational sections of this specification are not implied. Exposure to absolute maximum rating conditions for extended periods may affect reliability.

Package/Ordering Information

MODEL	CHANNEL	ORDER NUMBER	PACKAGE DESCRIPTION	PACKAGE OPTION	MARKING INFORMATION
LMV721	Single	LMV721ID	SC70-5	Tape and Reel,3000	721
		LMV721IDBV	SOT23-5	Tape and Reel,3000	721
		LMV721IDB	SOP-8	Tape and Reel,4000	LMV721
LMV722	Dual	LMV722IDB	SOP-8	Tape and Reel,4000	LMV722
		LMV722IDS	MSOP-8	Tape and Reel,3000	LMV722
		LMV721IDM	TSSOP-8	Tape and Reel,3000	LMV722
LMV724	Quad	LMV724ID	TSSOP-14	Tape and Reel,3000	LMV724
		LMV724IDB	SOP-14	Tape and Reel,2500	LMV724



Electrical Characteristics

(At $V_S=5V$, $T_A = +25^\circ C$, $V_{CM} = V_S/2$, $R_L = 600 \Omega$, unless otherwise noted.)

PARAMETER	CONDITIONS	LMV721/22/24							
		TYP	MIN/MAX OVER TEMPERATURE					UNITS	MIN / MAX
		+25°C	+25°C	0°C to 70°C	-40°C to 85°C	-40 °C to 125°C			
INPUT CHARACTERISTICS									
Input Offset Voltage (V_{OS})		0.8	3.5	3.9	4.3	4.6	mV	MAX	
Input Bias Current (I_B)		1					pA	TYP	
Input Offset Current (I_{OS})		1					pA	TYP	
Input Common Mode Voltage Range (V_{CM})	$V_S = 5.5V$	-0.1 to +5.6					V	TYP	
Common Mode Rejection Ratio (CMRR)	$V_S = 5.5V, V_{CM} = -0.1V$ to 4V	82	65	64	64	63	dB	MIN	
	$V_S = 5.5V, V_{CM} = -0.1V$ to 5.6V	75					dB	MIN	
Open-Loop Voltage Gain (A_{OL})	$R_L = 600\Omega, V_O = 0.15V$ to 4.85V	90	80	76	75	68	dB	MIN	
	$R_L = 10k\Omega, V_O = 0.05V$ to 4.95V	108					dB	MIN	
Input Offset Voltage Drift ($\Delta V_{OS}/\Delta T$)		2.4					$\mu V/^\circ C$	TYP	
OUTPUT CHARACTERISTICS									
Output Voltage Swing from Rail	$R_L = 600\Omega$	0.1					V	TYP	
	$R_L = 10k\Omega$	0.015					V	TYP	
Output Current (I_{OUT})		70	55	45	42	38	mA	MIN	
Closed-Loop Output Impedance	$f = 100kHz, G = 1$	7.5					Ω	TYP	
POWER-DOWN DISABLE									
Turn-On Time		1.1					μs	TYP	
Turn-Off Time		0.3					μs	TYP	
DISABLE Voltage-Off			0.8				V	MAX	
DISABLE Voltage-On			2				V	MIN	
POWER SUPPLY									
Operating Voltage Range			2.1	2.1	2.1	2.1	V	MIN	
			5.5	5.5	5.5	5.5	V	MAX	
Power Supply Rejection Ratio (PSRR)	$V_S = +2.5V$ to +5.5V $V_{CM} = (-V_S) + 0.5V$								
Quiescent Current/Amplifier (I_Q)	$I_{OUT} = 0$	91	74	72	72	68	dB	MIN	
		1.1	1.5	1.65	1.7	1.85	mA	MAX	



Electrical Characteristics

(At $V_S=5V$, $T_A = +25^\circ C$, $V_{CM} = V_S/2$, $R_L = 600\ \Omega$, unless otherwise noted.)

PARAMETER	CONDITIONS	LMV721/22/24							
		TYP	MIN/MAX OVER TEMPERATURE					UNITS	MIN / MAX
		+25°C	+25°C	0°C to 70°C	-40°C to 85°C	-40°C to 125°C			
DYNAMIC PERFORMANCE									
Gain-Bandwidth Product (GBP)	$R_L = 10k\Omega$, $C_L = 100pF$	11						MHz	TYP
Phase Margin (ϕ_o)	$R_L = 10k\Omega$, $C_L = 100pF$	51						Degrees	TYP
Full Power Bandwidth (BWP)	< 1% distortion, $R_L = 600\Omega$	400						kHz	TYP
Slew Rate (SR)	$G = +1$, 2V Step, $R_L = 10k\Omega$	9						V/ μs	TYP
Settling Time to 0.1% (t_s)	$G = +1$, 2V Step, $R_L = 600\Omega$	0.3						μs	TYP
Overload Recovery Time	$V_{IN} \cdot Gain = V_S$, $R_L = 600\Omega$	1.5						μs	TYP
NOISE PERFORMANCE									
Voltage Noise Density (e_n)	$f = 1kHz$	11.5						nV / \sqrt{Hz}	TYP
	$f = 10kHz$	8						nV / \sqrt{Hz}	TYP

Typical Performance characteristics

(At $V_s=5V$, $T_A = +25^\circ C$, $V_{CM} = V_s/2$, $R_L = 600\Omega$, unless otherwise noted.)

Large-Signal Step Response

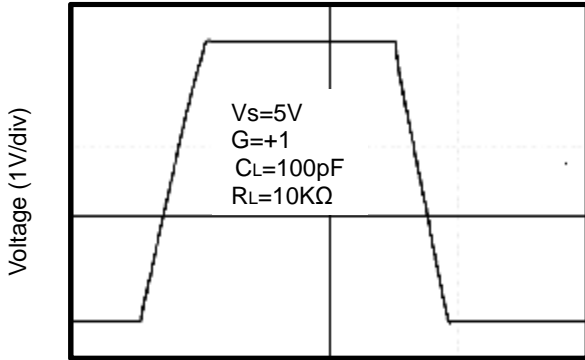

Time (1μs/div)

Large-Signal Step Response

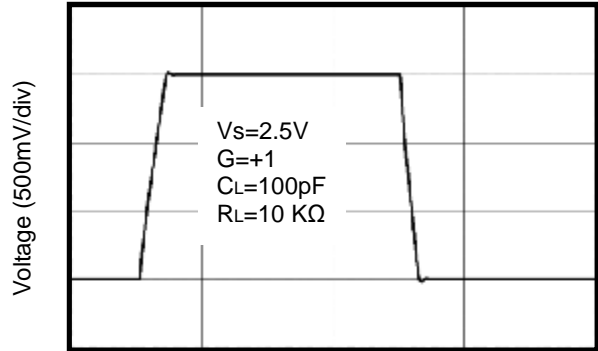

Time (1μs/div)

Small-Signal Step Response

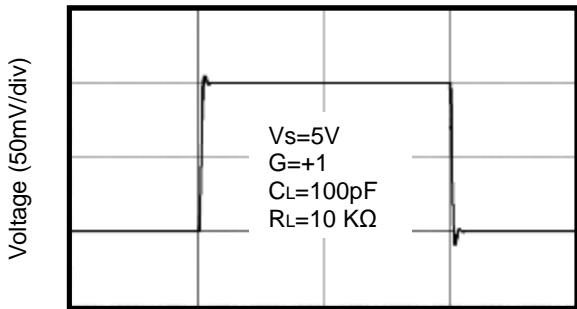

Time (1μs/div)

Small-Signal Step Response

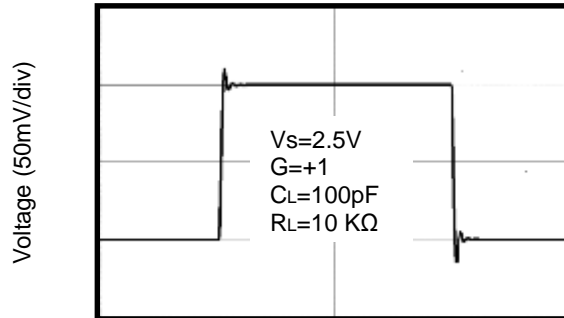

Time (1μs/div)

Positive Overload Recovery

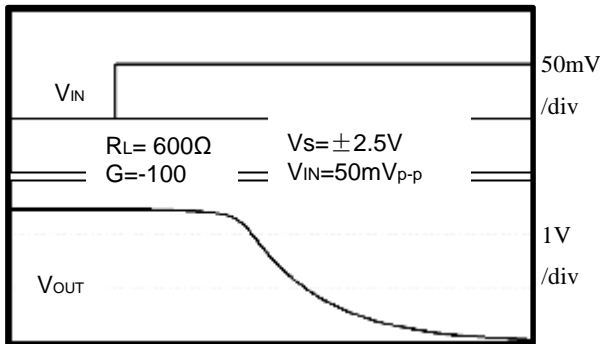

Time (2μs/div)

Negative Overload Recovery

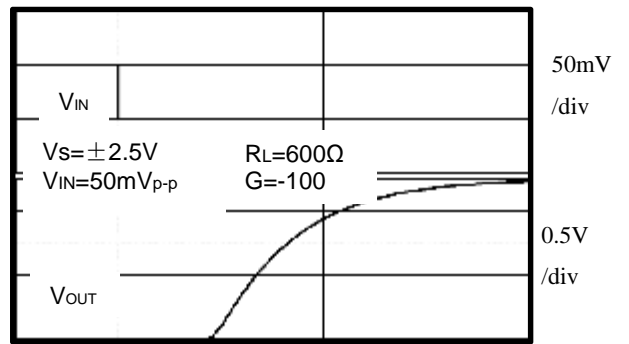

Time (2μs/div)

Typical Performance characteristics

(At $V_s=5V$, $T_A = +25^\circ C$, $V_{CM} = V_s/2$, $R_L = 600\Omega$, unless otherwise noted.)

Output Voltage Swing vs. Output Current

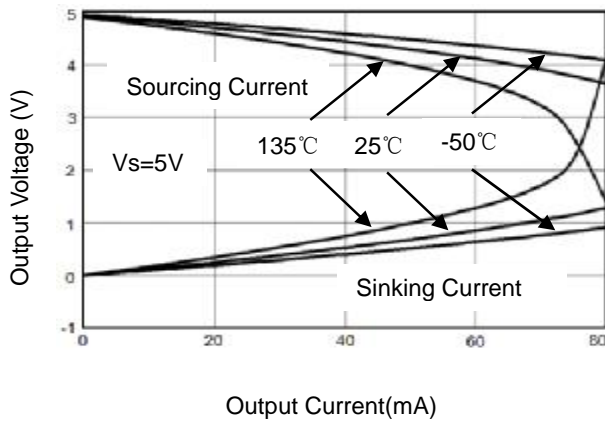

Supply Current vs. Temperature

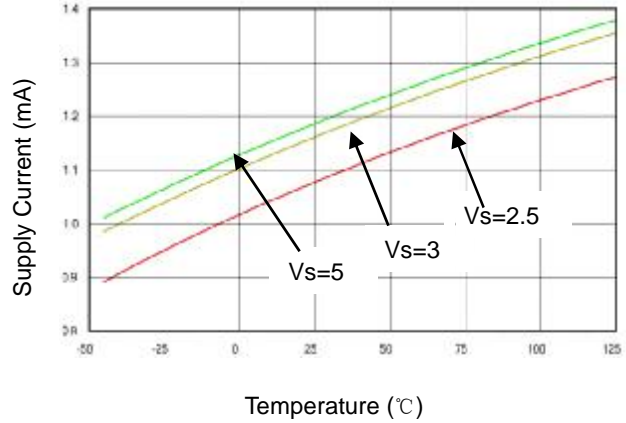

Input Voltage Noise Spectral Density vs. Frequency

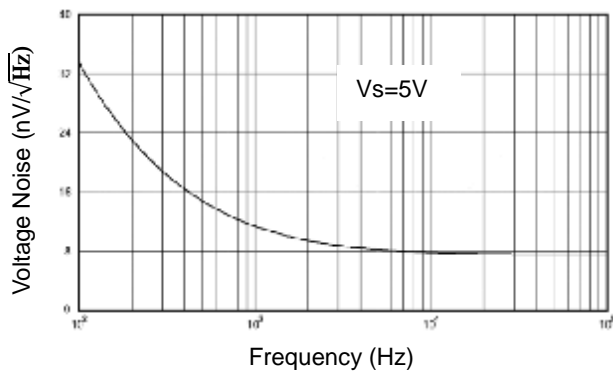

Open Loop Gain, Phase Shift vs. Frequency

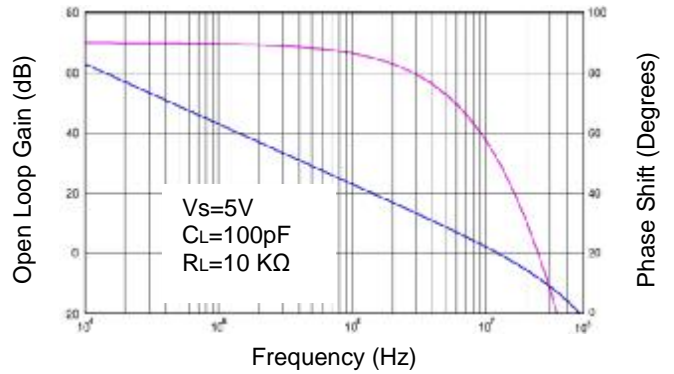

CMRR vs. Frequency

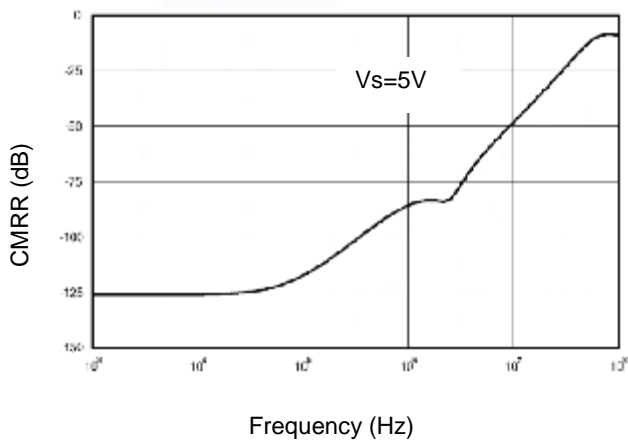

PSRR vs. Frequency

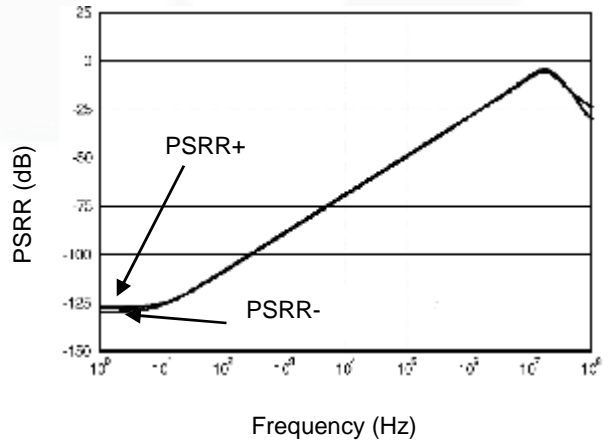

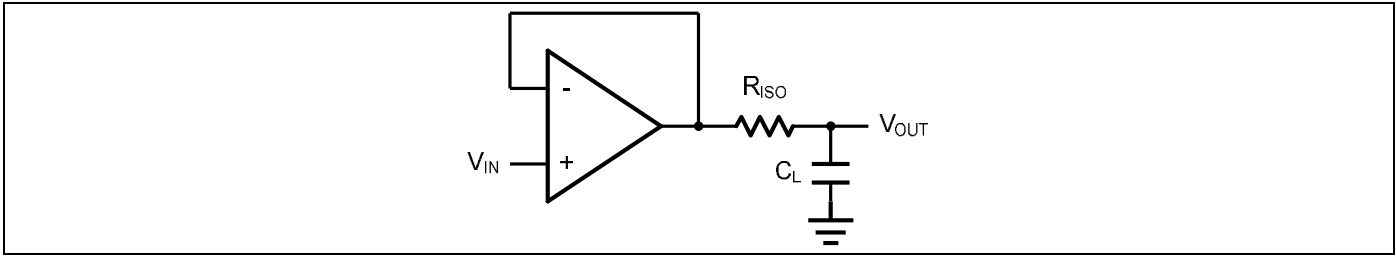

Figure 2. Indirectly Driving a Capacitive Load Using Isolation Resistor

The bigger the R_{ISO} resistor value, the more stable V_{OUT} will be. However, if there is a resistive load R_L in parallel with the capacitive load, a voltage divider (proportional to R_{ISO}/R_L) is formed, this will result in a gain error.

The circuit in Figure 3 is an improvement to the one in Figure 2. R_F provides the DC accuracy by feed-forward the V_{IN} to R_L . C_F and R_{ISO} serve to counteract the loss of phase margin by feeding the high frequency component of the output signal back to the amplifier's inverting input, thereby preserving the phase margin in the overall feedback loop. Capacitive drive can be increased by increasing the value of C_F . This in turn will slow down the pulse response.

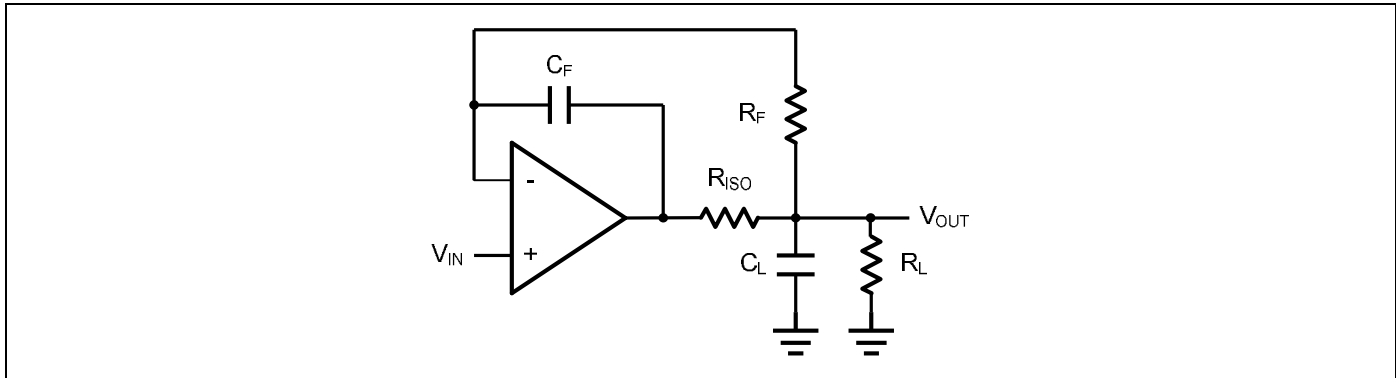

Figure 3. Indirectly Driving a Capacitive Load with DC Accuracy

Typical Application Circuits

Differential amplifier

The differential amplifier allows the subtraction of two input voltages or cancellation of a signal common the two inputs. It is useful as a computational amplifier in making a differential to single-end conversion or in rejecting a common mode signal. Figure 4. shown the differential amplifier using LMV721/22/24.

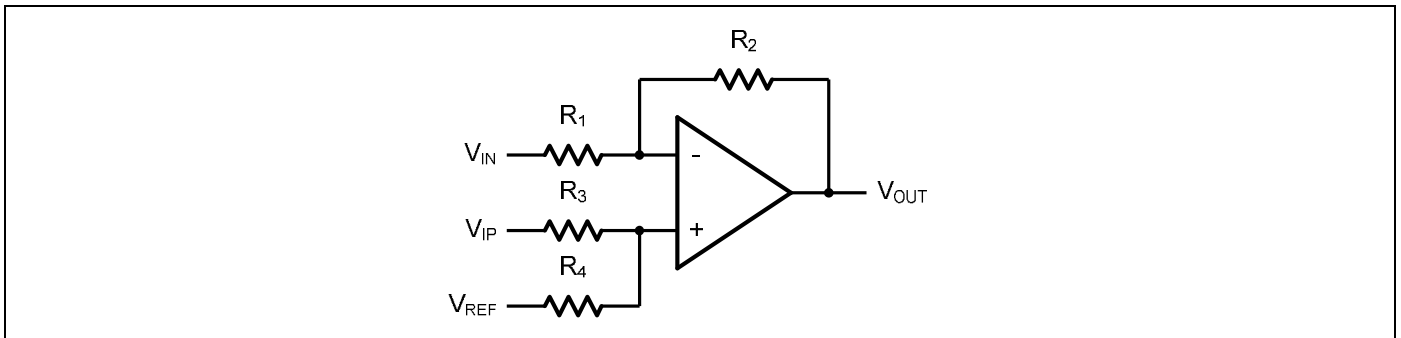

Figure 4. Differential Amplifier

$$V_{OUT} = \left(\frac{R_1 + R_2}{R_3 + R_4} \right) \frac{R_4}{R_1} V_{IN} - \frac{R_2}{R_1} V_{IP} + \left(\frac{R_1 + R_2}{R_3 + R_4} \right) \frac{R_3}{R_1} V_{REF}$$

If the resistor ratios are equal (i.e. $R_1 = R_3$ and $R_2 = R_4$), then

$$V_{OUT} = \frac{R_2}{R_1} (V_{IP} - V_{IN}) + V_{REF}$$

Low Pass Active Filter

The low pass active filter is shown in Figure 5. The DC gain is defined by $-R_2/R_1$. The filter has a -20dB/decade roll-off after its corner frequency $f_c = 1/(2\pi R_3 C_1)$.

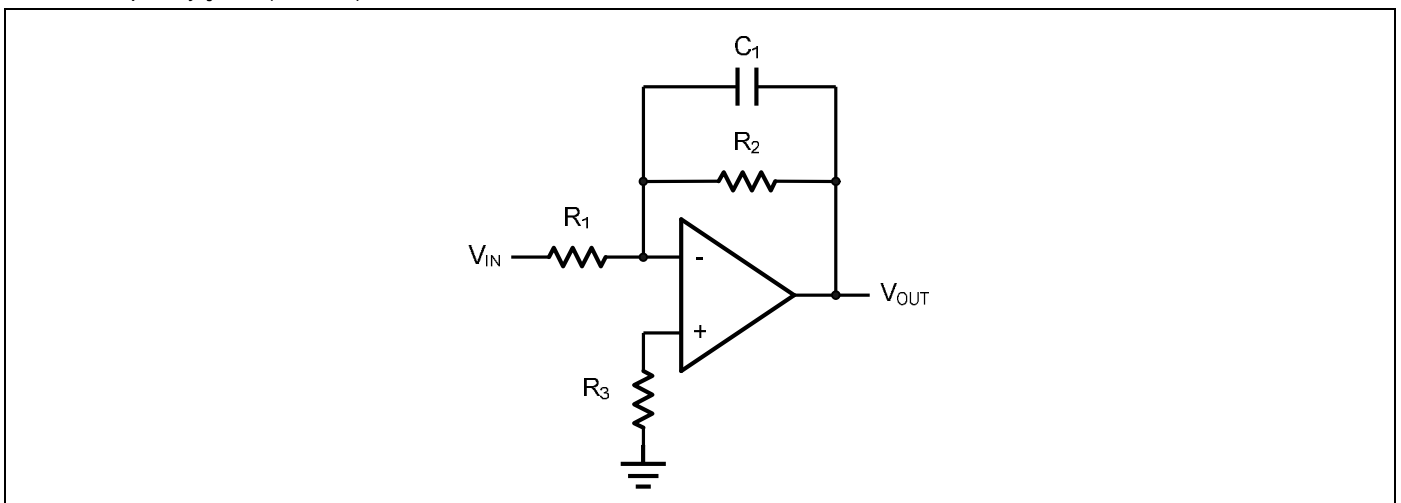

Figure 5. Low Pass Active Filter

Instrumentation Amplifier

The triple LMV721/22/24 can be used to build a three-op-amp instrumentation amplifier as shown in Figure 6. The amplifier in Figure 6 is a high input impedance differential amplifier with gain of R_2/R_1 . The two differential voltage followers assure the high input impedance of the amplifier

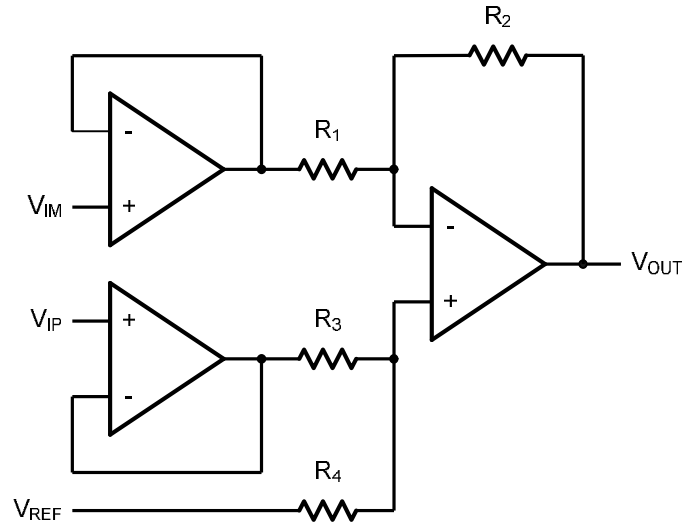
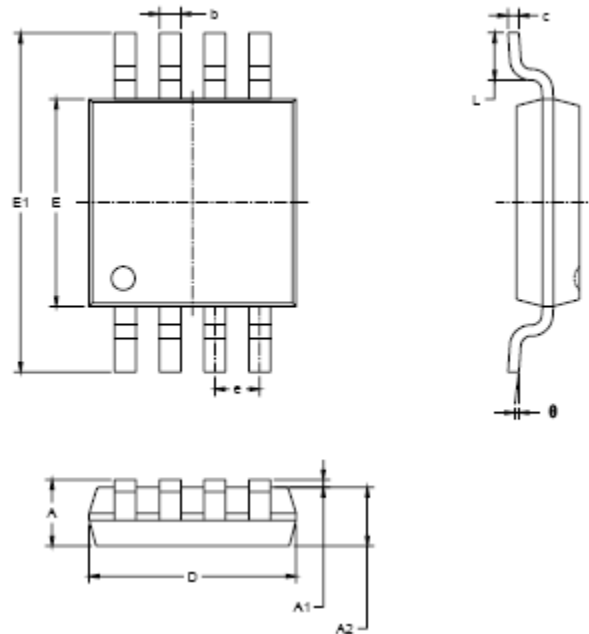

Figure 6. Instrument Amplifier

Package Information

MSOP-8



Symbol	Dimensions In Millimeters		Dimensions In Inches	
	MIN	MAX	MIN	MAX
A	0.820	1.100	0.032	0.043
A1	0.020	0.150	0.001	0.008
A2	0.750	0.950	0.030	0.037
b	0.250	0.380	0.010	0.015
c	0.090	0.230	0.004	0.009
D	2.900	3.100	0.114	0.122
E	2.900	3.100	0.114	0.122
E1	4.750	5.050	0.187	0.199
e	0.650 BSC		0.026 BSC	
L	0.400	0.800	0.016	0.031
θ	0°	8°	0°	8°

SOP-8

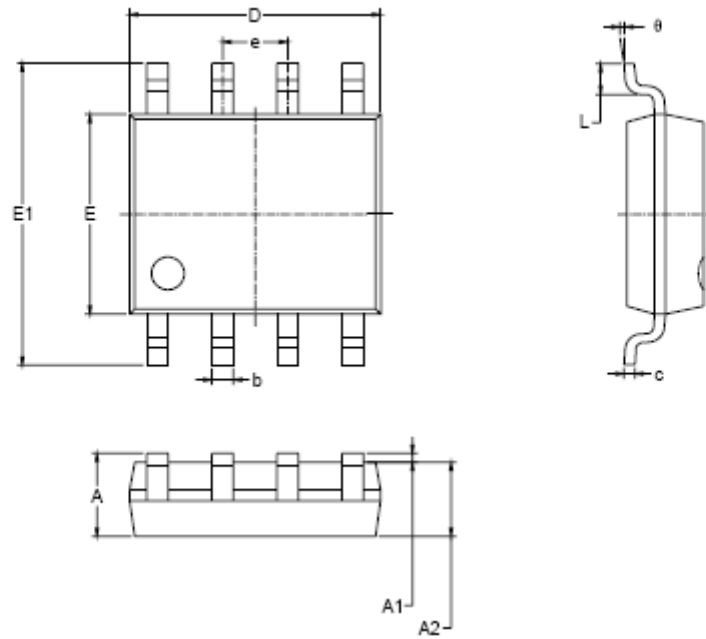

Symbol	Dimensions In Millimeters		Dimensions In Inches	
	MIN	MAX	MIN	MAX
A	1.350	1.750	0.053	0.069
A1	0.100	0.250	0.004	0.010
A2	1.350	1.550	0.053	0.061
b	0.330	0.510	0.013	0.020
c	0.170	0.250	0.006	0.010
D	4.700	5.100	0.185	0.200
E	3.800	4.000	0.150	0.157
E1	5.800	6.200	0.228	0.244
e	1.27 BSC		0.050 BSC	
L	0.400	1.270	0.016	0.050
θ	0°	8°	0°	8°

TSSOP-8

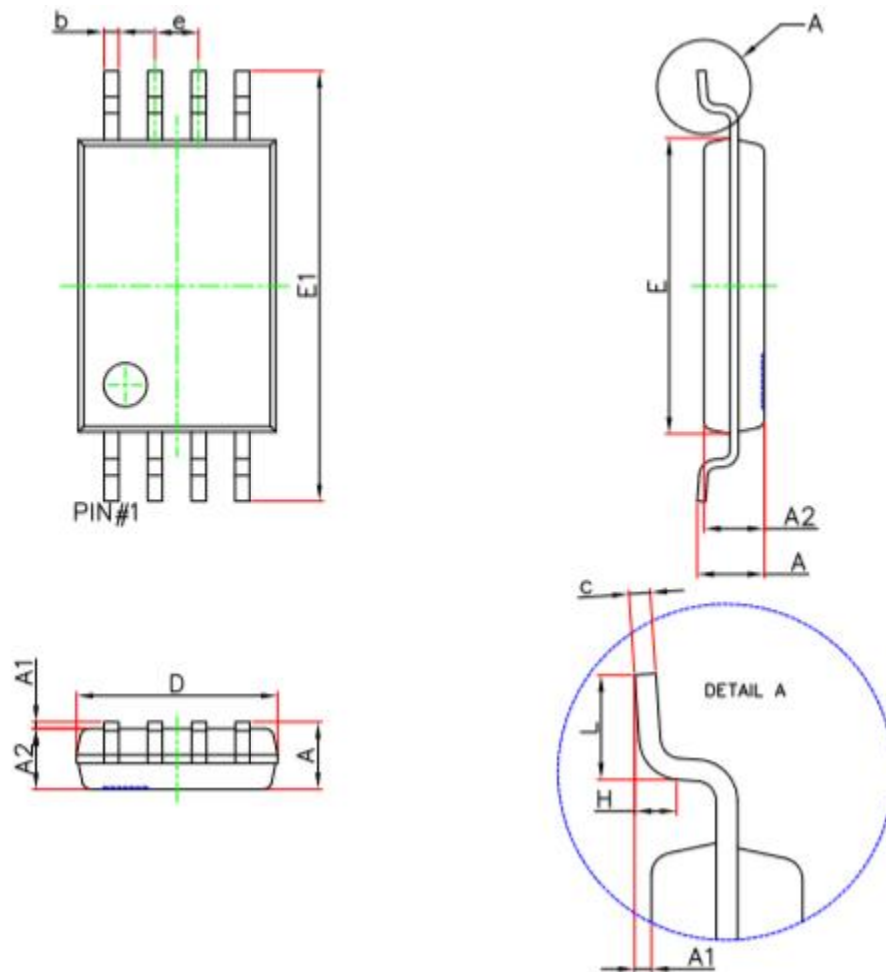

Symbol	Dimensions In Millimeters		Dimensions In Inches	
	Min.	Max.	Min.	Max.
D	4.900	5.100	0.193	0.201
E	4.300	4.500	0.169	0.177
b	0.190	0.300	0.007	0.012
c	0.090	0.200	0.004	0.008
E1	6.250	6.550	0.246	0.258
A	—	1.200	—	0.047
A2	0.800	1.000	0.031	0.039
A1	0.050	0.150	0.002	0.006
e	0.65 (BSC)		0.026 (BSC)	
L	0.500	0.700	0.020	0.028
H	0.25(TYP)		0.01(TYP)	
θ	1°	7°	1°	7°

SOT23-5

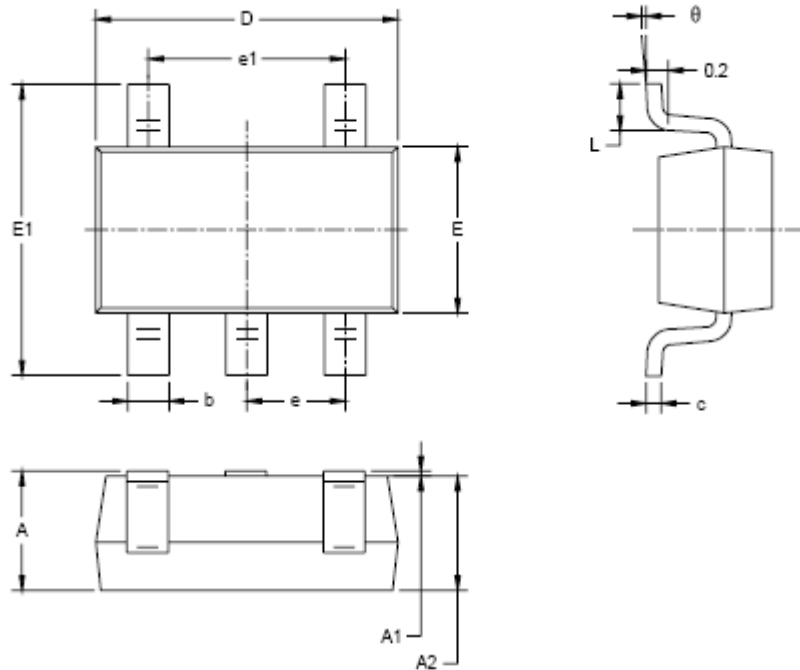

Symbol	Dimensions In Millimeters		Dimensions In Inches	
	MIN	MAX	MIN	MAX
A	1.050	1.250	0.041	0.049
A1	0.000	0.100	0.000	0.004
A2	1.050	1.150	0.041	0.045
b	0.300	0.500	0.012	0.020
c	0.100	0.200	0.004	0.008
D	2.820	3.020	0.111	0.119
E	1.500	1.700	0.059	0.067
E1	2.650	2.950	0.104	0.118
e	0.950 BSC		0.037 BSC	
e1	1.900 BSC		0.075 BSC	
L	0.300	0.600	0.012	0.024
θ	0°	8°	0°	8°

SOT23-6

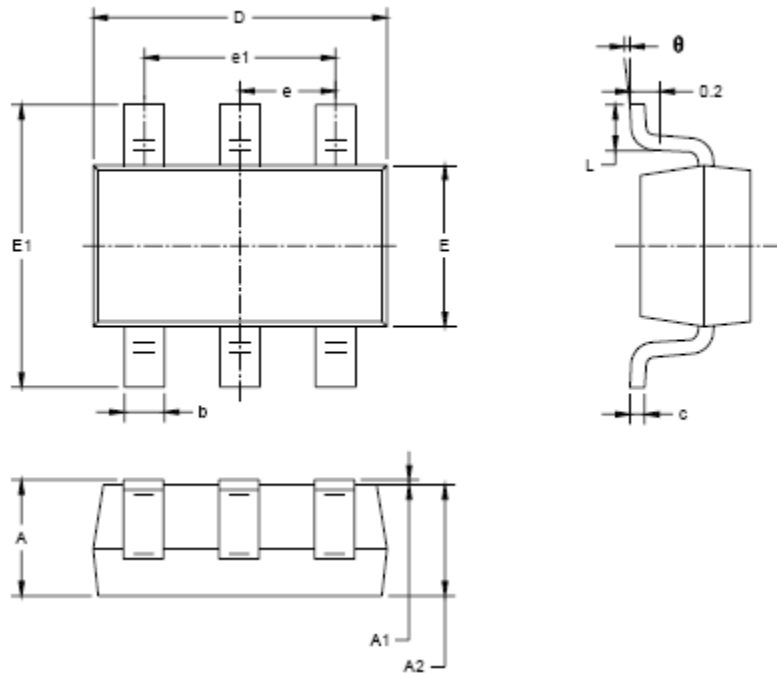

Symbol	Dimensions In Millimeters		Dimensions In Inches	
	MIN	MAX	MIN	MAX
A	1.050	1.250	0.041	0.049
A1	0.000	0.100	0.000	0.004
A2	1.050	1.150	0.041	0.045
b	0.300	0.500	0.012	0.020
c	0.100	0.200	0.004	0.008
D	2.820	3.020	0.111	0.119
E	1.500	1.700	0.059	0.067
E1	2.850	2.950	0.104	0.116
e	0.950 BSC		0.037 BSC	
e1	1.900 BSC		0.075 BSC	
L	0.300	0.800	0.012	0.024
θ	0°	8°	0°	8°

SC70-5

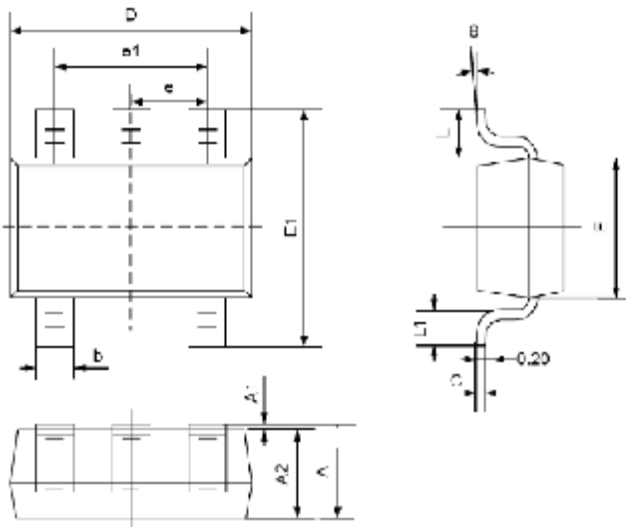

Symbol	Dimensions In Millimeters		Dimensions In Inches	
	Min	Max	Min	Max
A	0.900	1.100	0.035	0.043
A1	0.000	0.100	0.000	0.004
A2	0.900	1.000	0.035	0.039
b	0.150	0.350	0.006	0.014
C	0.080	0.150	0.003	0.006
D	2.000	2.200	0.079	0.087
E	1.150	1.350	0.045	0.053
E1	2.150	2.450	0.085	0.096
e	0.650TYP		0.026TYP	
e1	1.200	1.400	0.047	0.055
L	0.525REF		0.021REF	
L1	0.250	0.460	0.010	0.018
θ	0°	8°	0°	8°

TSSOP-14

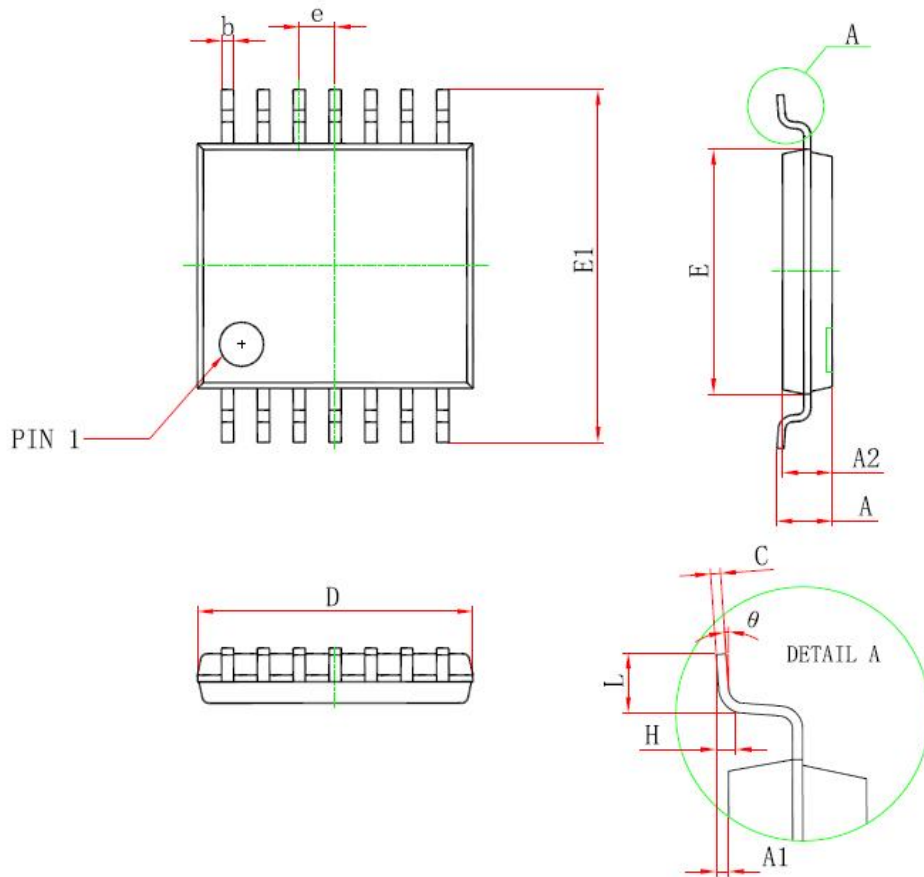

Symbol	Dimensions In Millimeters		Dimensions In Inches	
	Min	Max	Min	Max
D	4.900	5.100	0.193	0.201
E	4.300	4.500	0.169	0.177
b	0.190	0.300	0.007	0.012
c	0.090	0.200	0.004	0.008
E1	6.250	6.550	0.246	0.258
A		1.200		0.047
A2	0.800	1.000	0.031	0.039
A1	0.050	0.150	0.002	0.006
e	0.65 (BSC)		0.026 (BSC)	
L	0.500	0.700	0.020	0.028
H	0.25 (TYP)		0.01 (TYP)	
θ	1°	7°	1°	7°

SOP-14

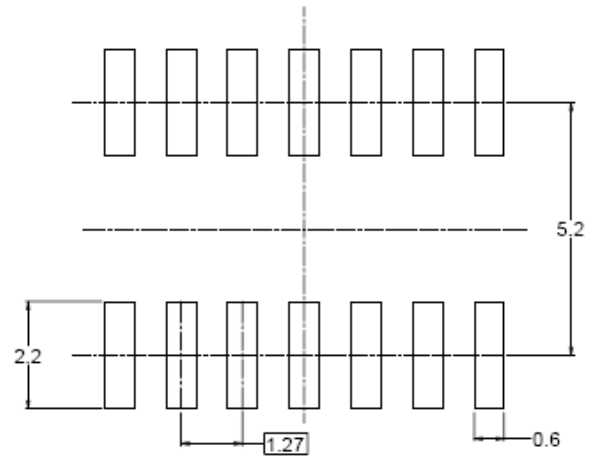
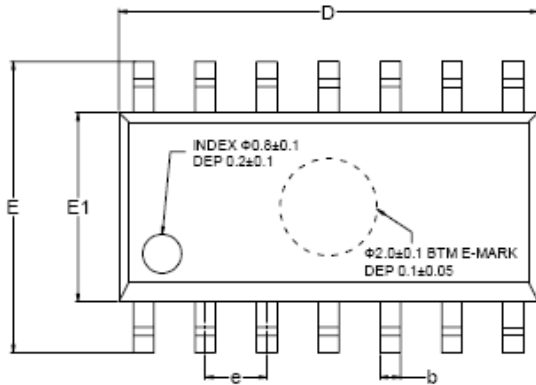

RECOMMENDED LAND PATTERN (Unit: mm)

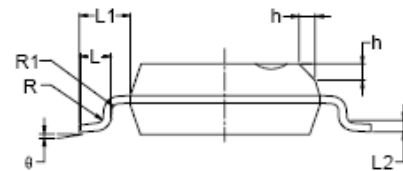
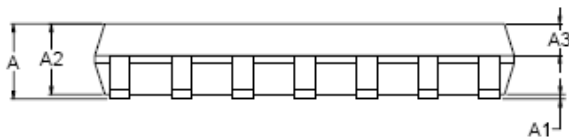

Symbol	Dimensions In Millimeters			Dimensions In Inches		
	MIN	MOD	MAX	MIN	MOD	MAX
A	1.35		1.75	0.053		0.069
A1	0.10		0.25	0.004		0.010
A2	1.25		1.65	0.049		0.065
A3	0.55		0.75	0.022		0.030
b	0.36		0.49	0.014		0.019
D	8.53		8.73	0.336		0.344
E	5.80		6.20	0.228		0.244
E1	3.80		4.00	0.150		0.157
e	1.27 BSC			0.050 BSC		
L	0.45		0.80	0.018		0.032
L1	1.04 REF			0.040 REF		
L2	0.25 BSC			0.01 BSC		
R	0.07			0.003		
R1	0.07			0.003		
h	0.30		0.50	0.012		0.020
θ	0°		8°	0°		8°

X-ON Electronics

Largest Supplier of Electrical and Electronic Components

Click to view similar products for [Operational Amplifiers - Op Amps](#) category:

Click to view products by [Tokmas](#) manufacturer:

Other Similar products are found below :

[430227FB](#) [LT1678IS8](#) [NCV33202DMR2G](#) [NJM324E](#) [M38510/13101BPA](#) [NTE925](#) [AZV358MTR-G1](#) [AP4310AUMTR-AG1](#)
[AZV358MMTR-G1](#) [SCY33178DR2G](#) [NCV20034DR2G](#) [NTE778S](#) [NTE871](#) [NTE937](#) [NJU7057RB1-TE2](#) [SCY6358ADR2G](#)
[NJM2904CRB1-TE1](#) [UPC4570G2-E1-A](#) [UPC4741G2-E1-A](#) [NJM8532RB1-TE1](#) [EL2250CS](#) [EL5100IS](#) [EL5104IS](#) [EL5127CY](#) [EL5127CYZ](#)
[EL5133IW](#) [EL5152IS](#) [EL5156IS](#) [EL5162IS](#) [EL5202IY](#) [EL5203IY](#) [EL5204IY](#) [EL5210CS](#) [EL5210CYZ](#) [EL5211IYE](#) [EL5220CY](#)
[EL5223CLZ](#) [EL5223CR](#) [EL5224ILZ](#) [EL5227CLZ](#) [EL5227CRZ](#) [EL5244CS](#) [EL5246CS](#) [EL5246CSZ](#) [EL5250IY](#) [EL5251IS](#) [EL5257IS](#)
[EL5260IY](#) [EL5261IS](#) [EL5300IU](#)