

## FEATURES

- 3.0V~5.5V Wide Power Range, Half-Duplex
- ESD Protection for RS-485 I/O Pins  $\pm 15\text{kV}$ , Human Body Model
- Bus Fault Tolerance and Withstand Voltage Reach  $\pm 15\text{V}$
- 1/8 Unit Load, Allow Up to 256 Transceivers on the Bus
- Driver Short-Circuit Output Protection
- Low Power Off Function
- Receiver Open-Circuit Failure Protection
- Strong Anti-Noise Ability
- Integrated Transient Voltage Suppression Function
- Data transmission up to 12Mbps in an electric noise environment

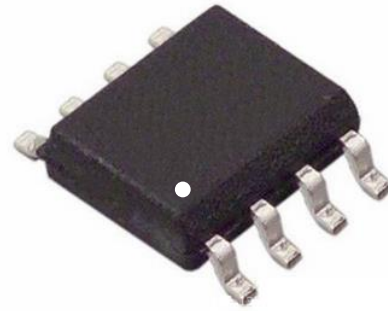

SOP-8

## DESCRIPTION

MAX3485 is a RS-485 transceiver with 3.0V~5.5V wide power supply, bus port ESD protection capacity of over 15kV HBM, bus withstand voltage range of  $\pm 15\text{V}$ , half duplex, low power consumption, and fully meet the requirements of TIA / EIA-485 standard.

MAX3485 includes a driver and a receiver, both of which can be enabled and closed independently. When both are disabled, both the driver and the receiver output are high resistance state. MAX3485 has 1/8 load, which allows 256 MAX3485 transceivers to be connected to the same communication bus. It can realize error-free data transmission up to 12Mbps.

MAX3485 has a working voltage range of 3.0~5.5V, and has the functions of fail safe, over temperature protection, current-limiting protection, over-voltage protection, etc.

## PIN CONFIGURATION

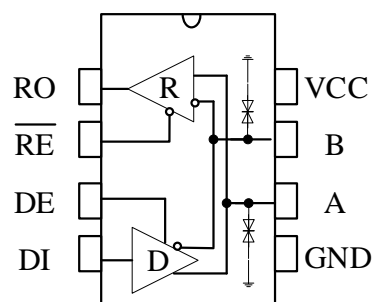

Figure 1 MAX3485 Pin Configuration

## LIMITING VALUES

PARAMETER	SYMBOL	VALUE	UNIT
Supply voltage	VCC	+7	V
Control Input Voltage	/RE, DE, DI	-0.3~VCC+0.5	V
Receiver Input Voltage	A, B	-15~+15	V
Receiver Output Voltage	RO	-0.3~VCC+0.5	V
Operating Temperature Ranges		-40~125	°C
Storage Temperature Range		-60~150	°C
Lead Temperature		300	°C
Continuous Power Dissipation	SOP8	470	mW
	MSOP8	830	mW
	DIP8	700	mW

The maximum limit parameters means that exceeding these values may cause irreversible damage to the device. Under these conditions, it is not conducive to the normal operation of the device. The continuous operation of the device at the maximum allowable rating may affect the reliability of the device. The reference point for all voltages is ground.

## PINNING

PIN	SYMBOL	DESCRIPTION
1	RO	Receiver Output. When /RE is low and if A - B $\geq$ -10mV, RO will be high; if A - B $\leq$ -200mV, RO will be low.
2	/RE	Receiver Output Enable. Drive /RE low to enable RO; RO is high impedance when /RE is high. Drive /RE high and DE low to enter low-power shutdown mode.
3	DE	Driver Output Enable. Drive DE high to enable driver outputs. These outputs are high impedance when DE is low. Drive /RE high and DE low to enter low-power shutdown mode.
4	DI	Driver Input. With DE high, a low on DI forces non-inverting output low and inverting output high. Similarly, a high on DI forces non-inverting output high and inverting output low.
5	GND	Ground
6	A	non-inverting Receiver Input and non-inverting Driver Output
7	B	Inverting Receiver Input and Inverting Driver Output
8	VCC	Positive Supply

**DRIVER DC ELECTRICAL CHARACTERISTICS**

PARAMETER	SYMBOL	CONDITION	MIN.	TYP.	MAX.	UNIT
Differential Driver Output (No load)	$V_{OD1}$		3		5.5	V
Differential Driver Output	$V_{OD2}$	Figure 2, $R_L = 54 \Omega$ , $V_{CC}=3.3V$	1.5		$V_{CC}$	V
		Figure 2, $R_L = 54 \Omega$ , $V_{CC}=5V$	1.5		$V_{CC}$	
Change in Magnitude of Driver Differential Output Voltage (NOTE1)	$\Delta V_{OD}$	Figure 2, $R_L = 54 \Omega$			0.2	V
Driver Common-Mode Output Voltage	$V_{OC}$	Figure 2, $R_L = 54 \Omega$			3	V
Change in Magnitude of Common-Mode Output Voltage (NOTE1)	$\Delta V_{OC}$	Figure 2, $R_L = 54 \Omega$			0.2	V
Input High Voltage	$V_{IH}$	DE, DI, /RE	2.0			V
Input Low Voltage	$V_{IL}$	DE, DI, /RE			0.8	V
Logic Input Current	$I_{IN1}$	DE, DI, /RE	-2		2	$\mu A$
Output short-circuit current, short-circuit to high	$I_{OSD1}$	short-circuit to 0V~12V			250	mA
Output short-circuit current, short-circuit to low	$I_{OSD2}$	short-circuit to -7V~0V	-250			mA

(Unless otherwise noted,  $Temp=T_{MIN} \sim T_{MAX}$ ,  $Temp=25^{\circ}C$ )

NOTE1:  $\Delta V_{OD}$  and  $\Delta V_{OC}$  are the changes in  $V_{OD}$  and  $V_{OC}$ , respectively, when the DI input changes state.

**RECEIVER DC ELECTRICAL CHARACTERISTICS**

PARAMETER	SYMBOL	CONDITION	MIN.	TYP.	MAX.	UNIT
Input current (A, B)	$I_{IN2}$	DE = 0 V, $V_{CC}=0$ 或 $3.3/5V$ $V_{IN} = 12 V$			125	$\mu A$
		DE = 0 V, $V_{CC}=0$ 或 $3.3/5V$ $V_{IN} = -7 V$	-100			$\mu A$

Positive input threshold voltage	$V_{IT+}$	$-7V \leq V_{CM} \leq 12V$			-10	mV
Reverse input threshold voltage	$V_{IT-}$	$-7V \leq V_{CM} \leq 12V$	-200			mV
Input hysteresis voltage	$V_{hys}$	$-7V \leq V_{CM} \leq 12V$	10	30		mV
Receiver Output High Voltage	$V_{OH}$	$I_{OUT} = -2.5mA,$ $V_{ID} = +200 mV$	$V_{CC}-1.5$			V
Receiver Output Low Voltage	$V_{OL}$	$I_{OUT} = +2.5mA,$ $V_{ID} = -200 mV$			0.4	V
Three-State Output Current at Receiver	$I_{OZR}$	$0.4 V < V_O < 2.4 V$			$\pm 1$	$\mu A$
Receiver Input Resistance	$R_{IN}$	$-7V \leq V_{CM} \leq 12V$	96			$k\Omega$
Receiver Short-Circuit Output Current	$I_{OSR}$	$0 V \leq V_O \leq V_{CC}$	$\pm 8$		$\pm 90$	mA

(Unless otherwise noted, Temp= $T_{MIN}$ ~ $T_{MAX}$ , Temp= $25^{\circ}C$ )

## SUPPLY CURRENT

PARAMETER	SYMBOL	CONDITION	MIN.	TYP.	MAX.	UNIT
Supply Current	$I_{CC1}$	/RE=0V, DE = 0 V, VCC=3.3V		240	650	$\mu A$
		/RE=0V, DE = 0 V VCC=5V		270	750	$\mu A$
	$I_{CC2}$	/RE=VCC, DE=VCC, VCC=3.3V		250	650	$\mu A$
		/RE=VCC, DE=VCC, VCC=5V		280	750	$\mu A$
Shutdown current	$I_{SHDN}$	/RE=VCC, DE=0V, VCC=3.3V		0.2	10	$\mu A$
		/RE=VCC, DE=0V, VCC=5V		0.2	10	$\mu A$

**DRIVER SWITCHING CHARACTERISTICS**

PARAMETER	SYMBOL	CONDITION	MIN.	TYP.	MAX.	UNIT
Driver differential Output delay	$t_{DD}$	$R_L = 60 \Omega$ , $C_{L1}=C_{L2}=100pF$ (figure3、 4)		20	40	ns
Driver differential output Transition time	$t_{TD}$			12	28	ns
Drive propagation delay From low to high	$t_{PLH}$	$R_L = 27 \Omega$ , (figure3、 4)		20	40	ns
Drive propagation delay From high to low	$t_{PHL}$			20	40	ns
$ t_{PLH}-t_{PHL} $	$t_{PDS}$			1	8	ns
Driver Enable to Output High	$t_{PZH}$	$R_L = 110\Omega$ , ( figure5、 6)			55	ns
Driver Enable to Output low	$t_{PZL}$				55	ns
Driver Disable Time from Low	$t_{PLZ}$	$R_L = 110\Omega$ , ( figure 5、 6)			85	ns
Driver Disable Time from high	$t_{PHZ}$				85	ns
In Shutdown mode, Enable to Output High	$t_{DSH}$	$R_L = 110\Omega$ , ( figure 5、 6)		20	100	ns
In Shutdown mode, Enable to Output low	$t_{DSL}$	$R_L = 110\Omega$ , ( figure 5、 6)		20	100	ns

**RECEIVER SWITCHING CHARACTERISTICS**

PARAMETER	SYMBOL	CONDITION	MIN.	TYP.	MAX.	UNIT
Receiver Input to output from low to high	$t_{RPLH}$	$C_L=15pF$ Figure7 & Figure8		60		ns
Receiver Input to output from high to low	$t_{RPHL}$				60	ns

$ t_{RPLH} - t_{RPHL} $	$t_{RPDS}$			3	10	ns
Receiver Enable to Output Low	$t_{RPZL}$	$C_L=15pF$ Figure7& Figure 8		15	40	ns
Receiver Enable to Output high	$t_{RPZH}$	$C_L=15pF$ Figure7 & Figure8		15	40	ns
Receiver Disable Time from Low	$t_{PRLZ}$	$C_L=15pF$ Figure7 & Figure8		25	55	ns
Receiver Disable Time from high	$t_{PRHZ}$	$C_L=15pF$ Figure7 & Figure8		25	55	ns
In Shutdown mode, Enable to Output High	$t_{RPSH}$	$C_L=15pF$ Figure7 & Figure8		150	500	ns
In Shutdown mode, Enable to Output low	$t_{RPSL}$	$C_L=15pF$ Figure7 & Figure8		150	500	ns
Time to Shutdown	$t_{SHDN}$	NOTE2	50		300	ns

NOTE2: If the enable inputs are RE=high and DE=low for less than 50ns, the device is guaranteed not to enter shutdown. If the enable inputs are in this state for at least 300ns, the device is guaranteed to have entered shutdown.

## FUNCTION TABLE

### Driver Function

CONTROL		INPUT	OUTPUT	
/RE	DE	DI	A	B
X	1	1	H	L
X	1	0	L	H
0	0	X	Z	Z
1	0	X	Z(shutdown)	

X=irrelevant; Z=high impedance

### Receiver Function

CONTROL		INPUT	OUTPUT
/RE	DE	A-B	RO
0	X	$\geq -10mV$	H
0	X	$\leq -200mV$	L
0	X	Open/short circuit	H
1	X	X	Z

X=irrelevant; Z=high impedance

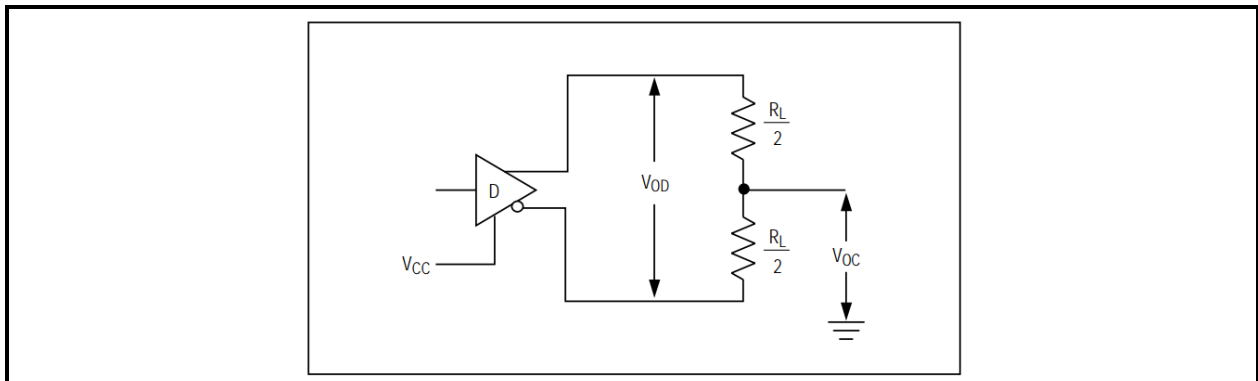
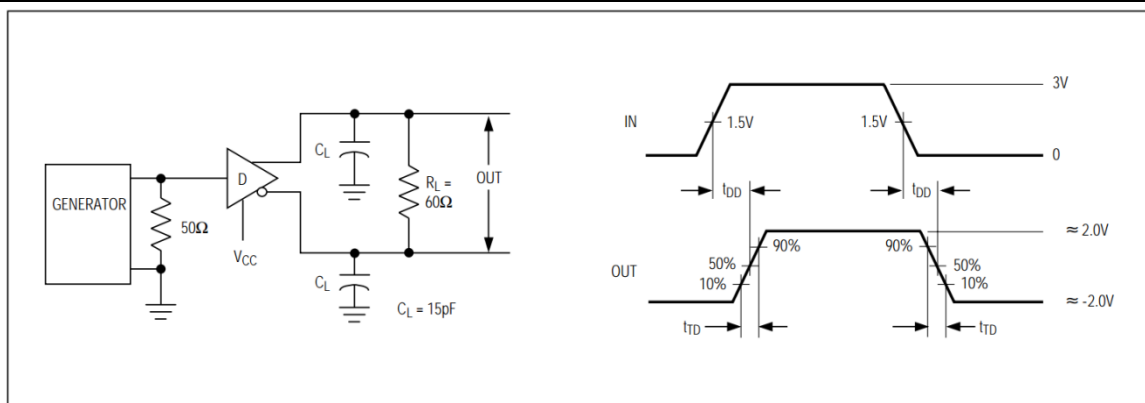
**TEST CIRCUIT**

**Figure 2 Driver DC test load**

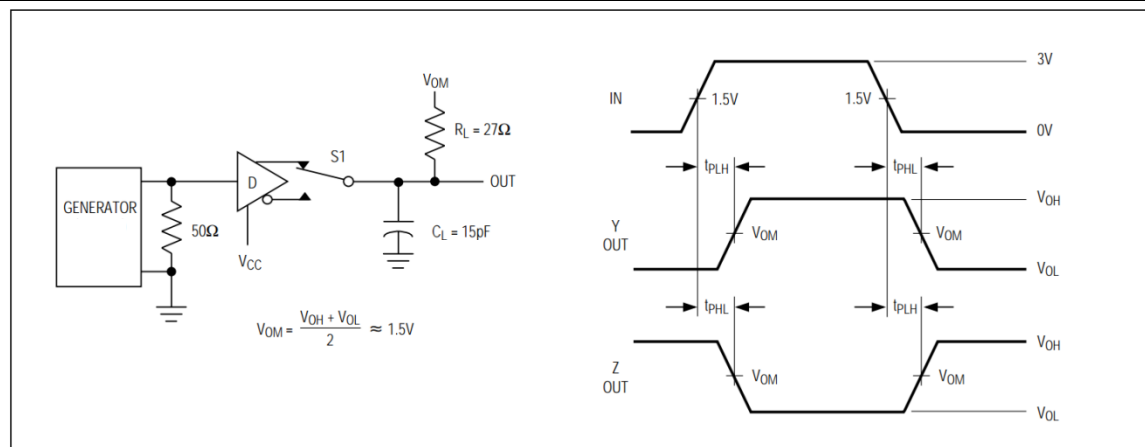
CL includes probe and stray capacitance (the same below)

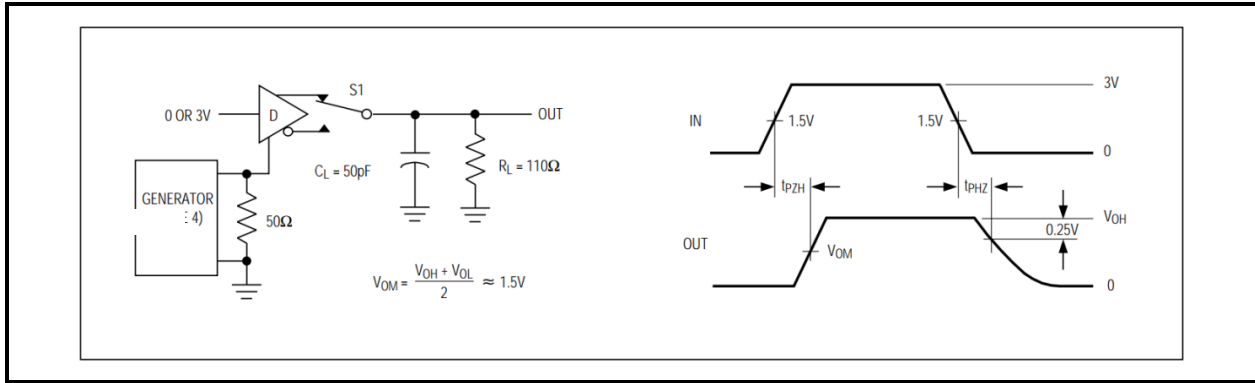
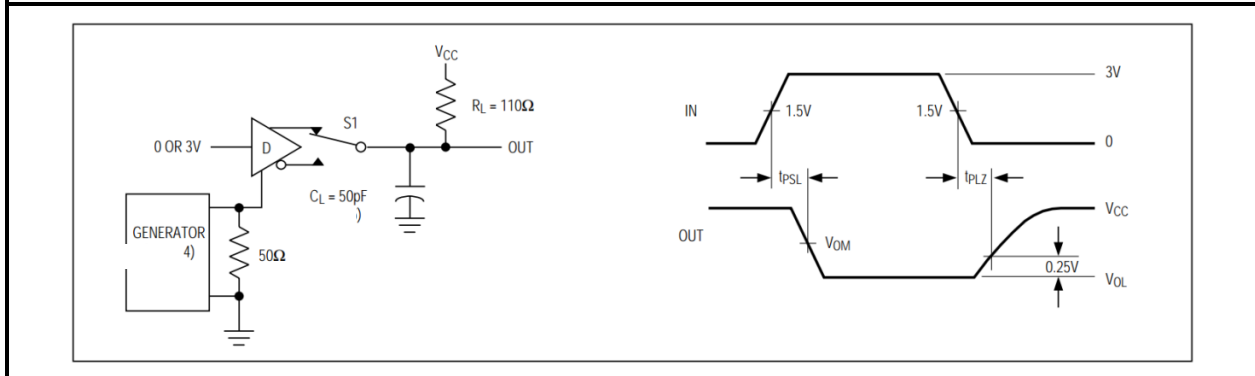
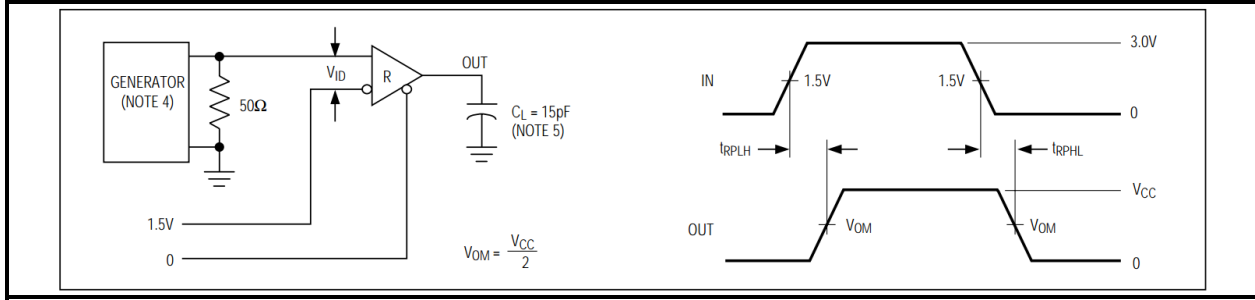
**Figure 3 Differential delay and transit time of driver**

**Figure 4 Drive propagation delay**

**Figure 5 Drive enable and disable time**

**Figure 6 Drive enable and disable time**

**Figure 7 Receiver propagation delay test circuit**



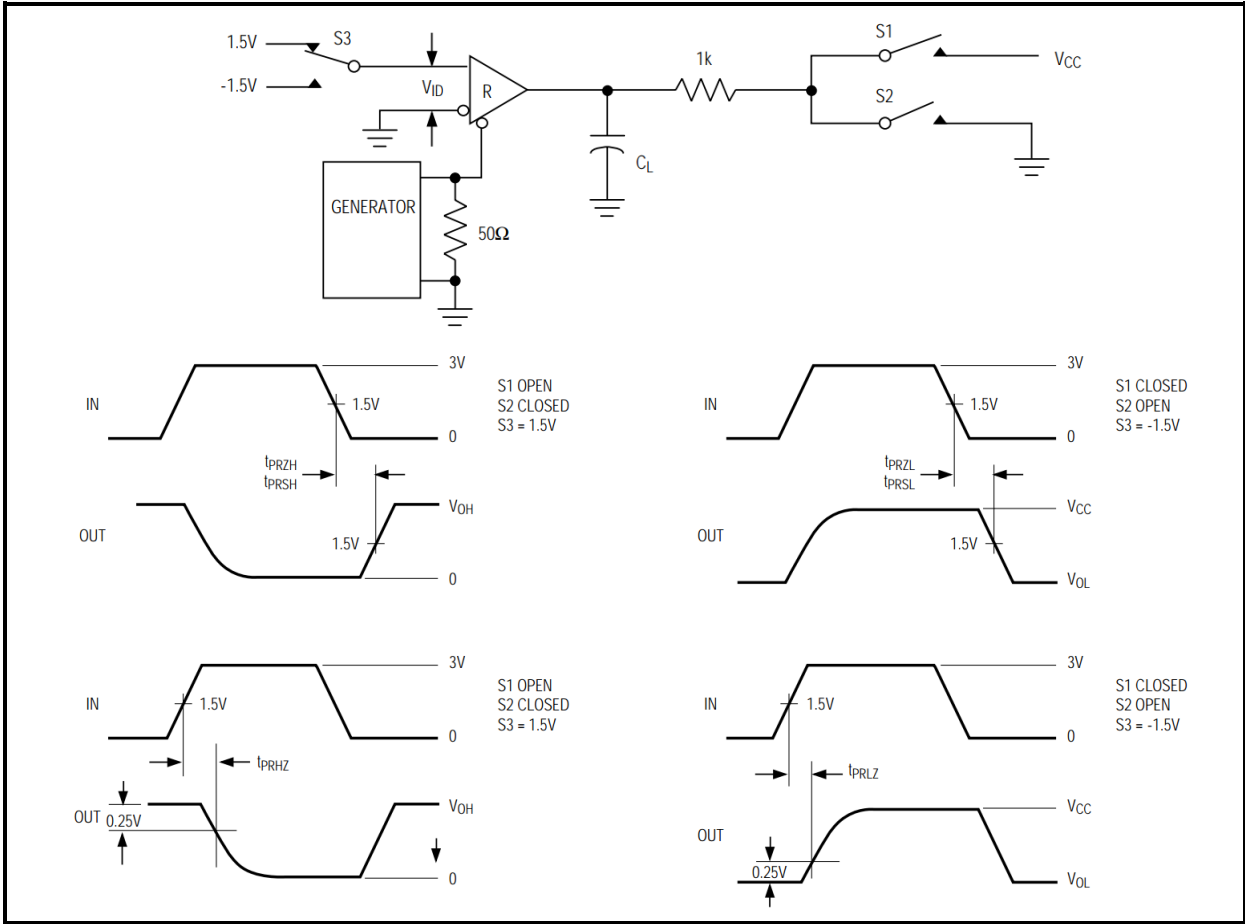

Figure 8 Receiver enable and disable time

## ADDITIONAL DESCRIPTION

### 1 Sketch

MAX3485E is a halfduplex high-speed transceiver with 3.0V~5.5V wide power supply, bus port ESD protection capacity of more than 15kV HBM, bus DC withstand voltage of more than  $\pm 15V$ , used for RS-485/RS-422 communication, including a driver and receiver. It has the functions of fail-safe, over-voltage protection, over-current protection and over temperature protection MAX3485E realizes error-free data transmission up to 12Mbps.

### 2 Allowing up to 256 Transceivers on the Bus

The input impedance of the standard RS485 receiver is  $12k\Omega$  (1 unit load), and the standard driver can drive up to 32 unit loads. The receiver of MAX3485E transceiver has 1/8 unit load input impedance ( $96k\Omega$ ), which allows up to 256 transceivers to be connected on the same communication bus in parallel. These devices can be combined arbitrarily or with other RS485 transceivers. Any combination of these devices and/or other RS-485 transceivers with a total of 32 unit loads or less can be connected to the line.

### 3 Driver output protection

Two mechanisms prevent excessive output current and power dissipation caused by faults or by bus contention. First, over-current protection, fast short circuit protection in the mode voltage range (refer to typical operating characteristics). Second, when the temperature of the tube core exceeds  $140^{\circ}C$ , the output of the driver is forced into the high resistance state.

### 4 Typical Applications

4.1 Bus Networking: MAX3485E RS485 transceiver is designed for bidirectional data communication on multi-point bus transmission line. Figure 9 shows a typical network application circuit. These devices can also be used as linear repeaters with cables longer than 4000 feet. In order to reduce reflection, terminal matching should be carried out at both ends of the transmission line with its characteristic impedance, and the length of branch lines outside the main line should be as short as possible.

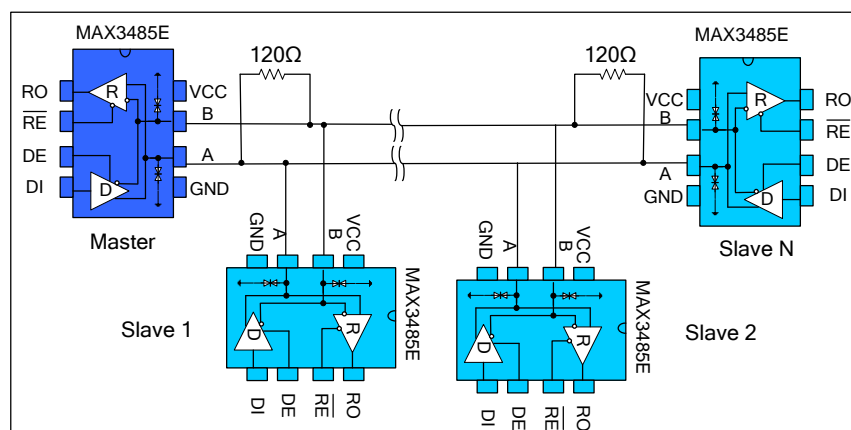

Figure 9 Bus type RS485 half duplex communication network

4.2 Hand in hand Networking: also known as daisy chain topology, is the standard and specification of RS485 bus wiring, and is the RS485 bus topology recommended by TIA and other organizations. The wiring mode is that the main control equipment and a plurality of slave control equipment form a hand-held connection mode, as shown in Figure 10, and the hand-held mode is no branches. This wiring mode has the advantages of small signal reflection and high communication success rate.

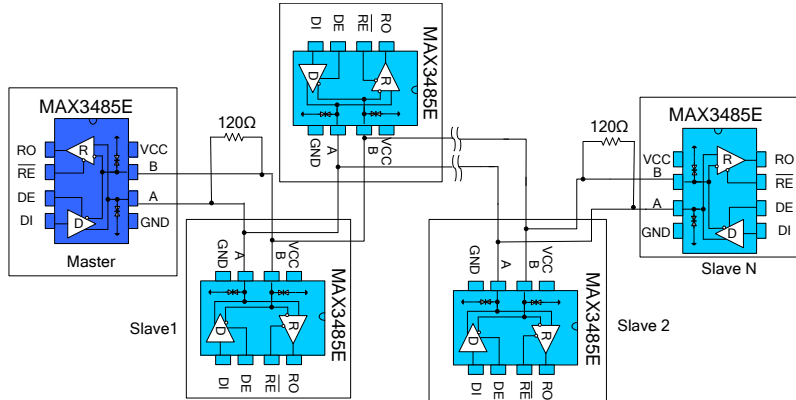

Figure10 Hand in hand RS485 half duplex communication network

4.3 Bus port protection: in severe environment, RS485 communication port is usually provided with electrostatic protection, lightning surge protection and other additional protection, and even the plan to prevent 380V market electricity access is needed to avoid the damage of intelligent instrument and industrial control host. Figure 11 shows three common RS485 bus port protection schemes. The first is the scheme of three-level protection by connecting TVS devices in parallel with A,B port to the protective ground, TVS devices in parallel with A,B port, thermistor in series with A,B port, gas discharge tube in parallel to the protective ground; the second is the scheme of three-level protection by connecting TVS in parallel with A,B port to the ground, thermistor in series with A,B port, and varistor in parallel with A,B port; the third is the scheme of three-level protection by connecting AB with pull-up or pull-down resistor to power and ground respectively, connecting TVS between A & B, A or B port connecting thermistor.

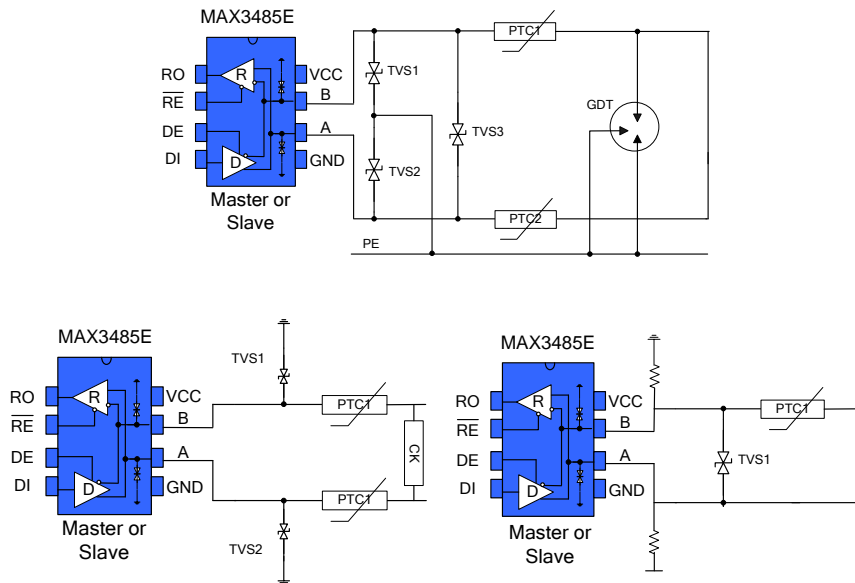
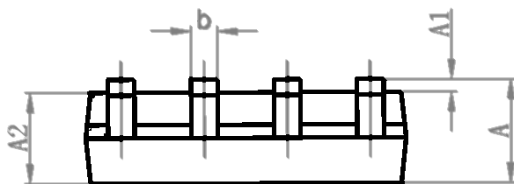
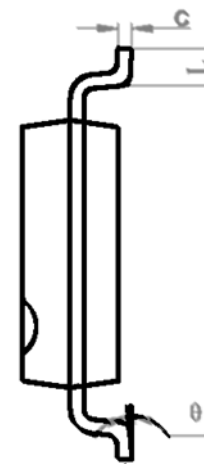
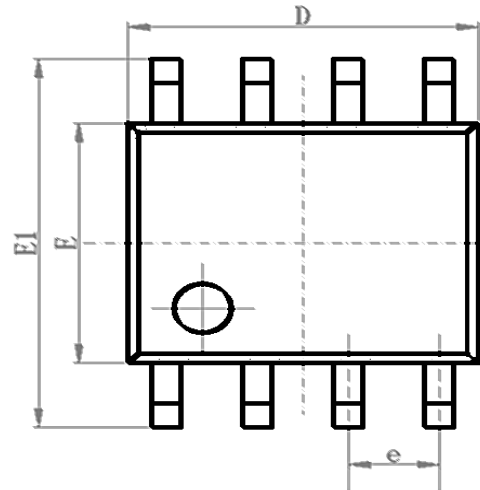

Figure 11 Port protection scheme

**SOP8 DIMENSIONS**
**PACKAGE SIZE**

SYMBOL	MIN./mm	TYP./mm	MAX./mm
A	1.40	-	1.80
A1	0.10	-	0.25
A2	1.30	1.40	1.50
b	0.38	-	0.51
D	4.80	4.90	5.00
E	3.80	3.90	4.00
E1	5.80	6.00	6.20
e		1.27BSC	
L	0.40	0.60	0.80
c	0.20	-	0.25
$\theta$	0°	-	8°



MSOP8 / 8 $\mu$ MAX / VSSOP8 DIMENSIONS

## PACKAGE SIZE

SYMBOL	MIN./mm	TYP./mm	MAX./mm
A	2.90	3.0	3.10
A1	0.28		0.35
A2	0.65TYP		
A3	0.375TYP		
B	2.90	3.0	3.10
B1	4.70		5.10
B2	0.45		0.75
C	0.75		0.95
C1			1.10
C2	0.328 TYP		
C3	0.152		
C4	0.15		0.23
H	0.00		0.09
$\theta$	12°TYP		

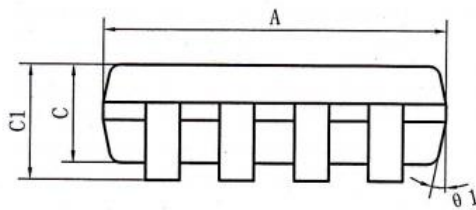
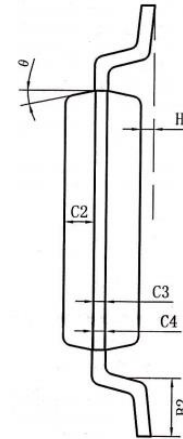
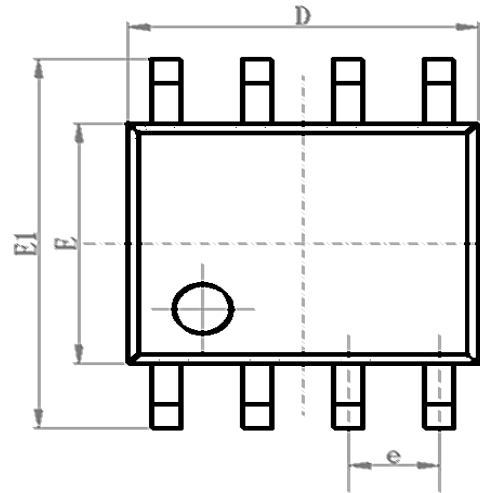

**DIP8 DIMENSIONS**

Package size			
SYMBOL	MIN./mm	TYP./mm	MAX./mm
A	9.00	9.20	9.40
A1	0.33	0.45	0.51
A2	2.54TYP		
A3	1.525TYP		
B	8.40	8.70	9.10
B1	6.20	6.40	6.60
B2	7.32	7.62	7.92
C	3.20	3.40	3.60
C1	0.50	0.60	0.80
C2	3.71	4.00	4.31
D	0.20	0.28	0.36
L	3.00	3.30	3.60

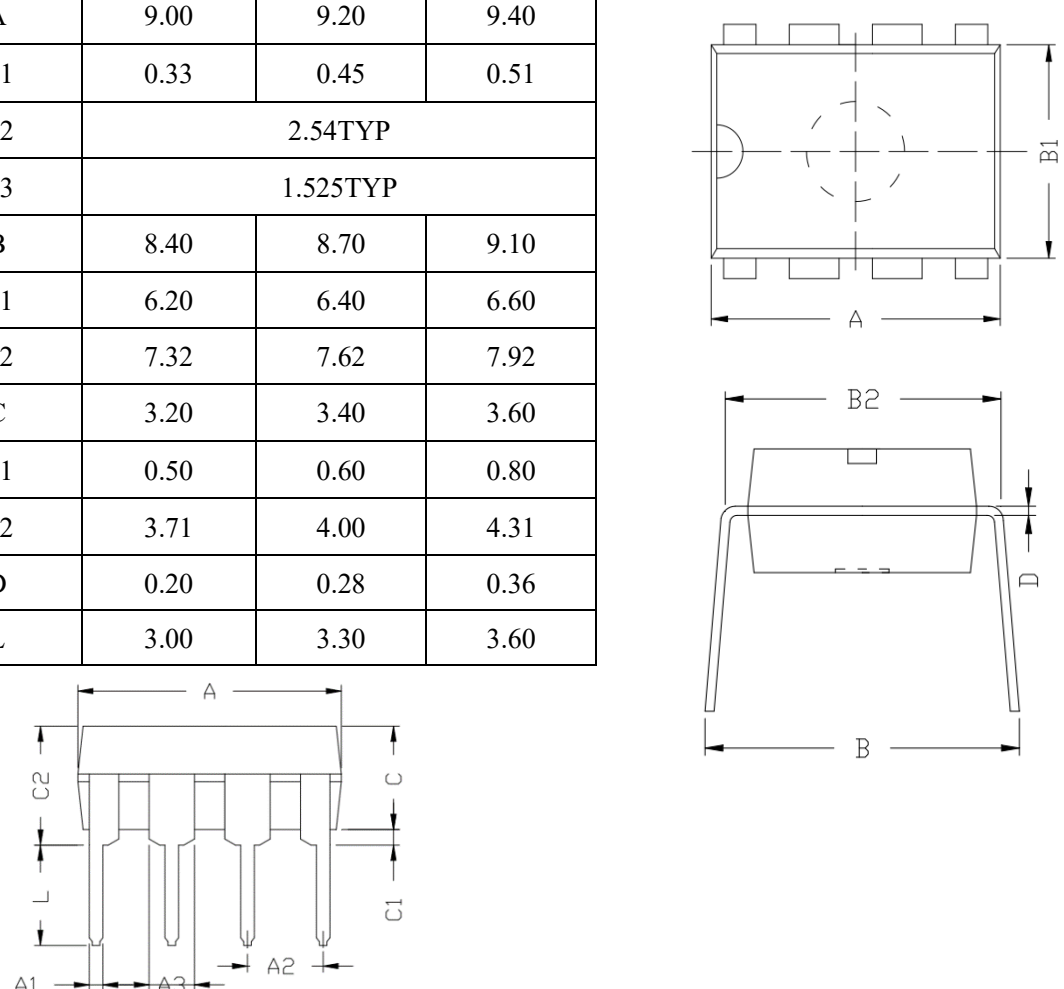
**ORDERING INFORMATION**

TYPE NUMBER	TEMPERATURE	PACKAGE
MAX3485ESA+T	-40°C~125°C	SOP8
MAX3485EEUA	-40°C~125°C	MSOP8/VSSOP8/8μMAX
MAX3485EEPA	-40°C~125°C	DIP8

Tapered package is 2500 pcs/reel. The HVSON8/DFN3\*3-8 package is 5000 pcs/reel.

## X-ON Electronics

Largest Supplier of Electrical and Electronic Components

*Click to view similar products for [RS-422/RS-485 Interface IC](#) category:*

*Click to view products by [Tokmas](#) manufacturer:*

Other Similar products are found below :

[SP3494CN-L/TR](#) [ISL4486IBZ-T](#) [ISL4491EIB](#) [ISL4491EIBZ-T](#) [ISL81483IB](#) [ISL83086EIB](#) [ISL83088EIB](#) [ISL83488IB](#) [ISL8483EIB](#)  
[ISL8487EIB](#) [ISL8489EIB](#) [ISL8491IP](#) [ADM489AN](#) [CA-IF4820HM](#) [CS48505M](#) [CS485S](#) [CS817x22HS](#) [MAX485ESA-MS](#) [MAX3085](#)  
[ADM3485EARZ](#) [SP3485EEN](#) [MAX3485ESA](#) [ST3485EBDR](#) [ADM485ARZ](#) [CA-IF4820HD](#) [CA-IF1042S-Q1](#) [CA-IF1021D-Q1](#) [CS48520D](#)  
[SN65HVD78EIMM/TR](#) [HGX3085ECMM/TR](#) [SP3085EIMM/TR](#) [HGX3085EIMM/TR](#) [SN65HVD72EIMM/TR](#) [HGX485EIN](#) [RS1905XK](#)  
[SIT1044QTK](#) [THVD1420DR](#) [MAX3490EESA+T](#) [UM3483EESA](#) [HD588L](#) [HD568N](#) [HD688ADR](#) [CA-IS3080WX](#) [CA-IS3086WX](#)  
[CS817x20HS](#) [CA-IF1044S-Q1](#) [CA-IF4820FS](#) [CA-IF4850HS](#) [GM3490E](#) [WS339E](#)