

## FEATURES

- 3.0V~5.5V Supply, Full-duplex
- 1/8 Unit Load, Allow Up to 256 Transceivers on the Bus
- Driver Short-Circuit Output Protection
- Strong Anti-Noise Ability
- Integrated Transient Voltage Suppression Function
- The Data Transmission Rate Up to 14Mbps in Electric Noise Environment
- ESD Protection for RS-485 I/O Pins  $\pm 15\text{kV}$ , Human Body Model

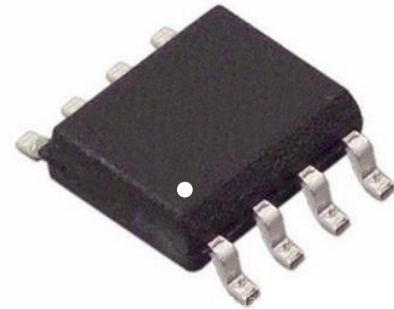

SOP-8

## DESCRIPTION

MAX3490E is a 3.0V~5.5V powered, full-duplex, low power dissipation RS-485 transceiver fully meeting the requirements of RS-485/RS-422 standard.

MAX3490E contains one driver and one receiver, both can transmit signals independently. The MAX3490E has a 1/8-unit-load. It allows up to 256 transceivers on the bus and error-free data transmission up to 14Mbps.

MAX3490E has a working voltage range of 3.0V~5.5V, with the functions of Current-Limiting Protection, Over-voltage Protection, Control Port Hot Plug Input, etc.

MAX3490E has excellent ESD release capability, and HBM reaches  $\pm 15\text{kV}$ .

## PIN CONFIGURATION

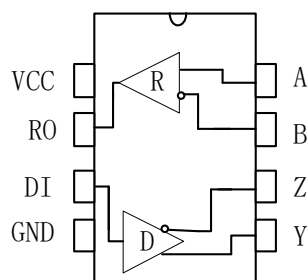

Figure 1 MAX3490E Pin Configuration

## LIMITING VALUES

PARAMETER	SYMBOL	VALUE	UNIT
Supply voltage	VCC	+7	V
Driver Input Voltage	DI	-0.3~VCC+0.3	V
Receiver Input Voltage	A, B	-8~13	V
Receiver Output Voltage	RO	-0.3~VCC+0.3	V
Operating Temperature Ranges	T <sub>A</sub>	-40~125	°C
Storage Temperature Range	T <sub>stg</sub>	-60~150	°C
Lead Temperature		300	°C
Continuous Power Dissipation	SOP8	400	mW
	DIP8	700	mW

The maximum limit parameters mean that exceeding these values may cause irreversible damage to the device. Under these conditions, it is not conducive to the normal operation of the device. The continuous operation of the device at the maximum allowable rating may affect the reliability of the device. The reference point for all voltages is ground.

## PINNING

PIN	SYMBOL	DESCRIPTION
1	VCC	Positive Supply: $3.0V \leq VCC \leq 5.5V$
2	RO	Receiver Output. If A-B $\geq +200mV$ , RO will be high; If A-B $\geq -200mV$ , RO will be low.
3	DI	Driver Input. A low on DI forces output Y low and output Z high. a high on DI forces output Y high and output Z low.
4	GND	Ground
5	Y	Non-inverting Driver Output
6	Z	Inverting Driver Output
7	B	Inverting Receiver Input
8	A	Non-inverting Receiver Input

## DRIVER DC ELECTRICAL CHARACTERISTICS

PARAMETER	SYMBOL	CONDITION	MIN	TYP	MAX	UNIT
Differential Driver Output (No load)	$V_{OD1}$			5		V
Differential Driver Output	$V_{OD2}$	Figure 2, $R_L = 27 \Omega$	1.5		VCC	V
		Figure 2, $R_L = 50 \Omega$	2		VCC	
Change in Magnitude of Driver Differential Output Voltage (NOTE1)	$\Delta V_{OD}$	Figure 2, $R_L = 27 \Omega$			0.2	V
Driver Common-Mode Output Voltage	$V_{OC}$	Figure 2, $R_L = 27 \Omega$			3	V
Change in Magnitude of Common-Mode Output Voltage (NOTE1)	$\Delta V_{OC}$	Figure 2, $R_L = 27 \Omega$			0.2	V
Input High Voltage	$V_{IH}$	DI	2.0			V
Input Low Voltage	$V_{IL}$	DI			0.8	V
Logic Input Current	$I_{IN1}$	DI	-2		2	$\mu A$
Output short-circuit current, short-circuit to high	$I_{OSD1}$	short-circuit to 0V~12V	35		250	mA
Output short-circuit current, short-circuit to low	$I_{OSD2}$	short-circuit to 7V~0V	-250		-35	mA

(Unless otherwise noted,  $V_{CC}=3.3V\pm 10\%$ ,  $Temp=T_{MIN}\sim T_{MAX}$ , typical values are at  $V_{CC}=+3.3V$ ,  $Temp=25^\circ C$ )

NOTE1:  $\Delta V_{OD}$  and  $\Delta V_{OC}$  are the changes in  $V_{OD}$  and  $V_{OC}$ , respectively, when the DI input changes state.

## RECEIVER DC ELECTRICAL CHARACTERISTICS

PARAMETER	SYMBOL	CONDITION	MIN	TYP	MAX	UNIT
Input current (A, B)	$I_{IN2}$	$V_{CC}=0$ or 3.3V $V_{IN}=12V$			125	$\mu A$
		$V_{CC}=0$ or 3.3V $V_{IN}=-7V$	-100			$\mu A$

PARAMETER	SYMBOL	CONDITION	MIN	TYP	MAX	UNIT
Positive input threshold voltage	$V_{IT+}$	$-7V \leq V_{CM} \leq 12V$			+200	mV
Reverse input threshold voltage	$V_{IT-}$	$-7V \leq V_{CM} \leq 12V$	-200			mV
Input hysteresis voltage	$V_{hys}$	$-7V \leq V_{CM} \leq 12V$	10	30		mV
Receiver Output High Voltage	$V_{OH}$	$I_{OUT} = -4mA$ , $V_{ID} = +200 mV$	$V_{CC} - 1.5$			V
Receiver Output Low Voltage	$V_{OL}$	$I_{OUT} = +4mA$ , $V_{ID} = -200 mV$			0.4	V
Three-State Output Current at Receiver	$I_{OZR}$	$0.4 V < V_O < 2.4 V$			$\pm 1$	$\mu A$
Receiver Input Resistance	$R_{IN}$	$-7V \leq V_{CM} \leq 12V$	96			k $\Omega$
Receiver Short-Circuit Output Current	$I_{OSR}$	$0 V \leq V_O \leq V_{CC}$	$\pm 7$		$\pm 95$	mA

(Unless otherwise noted,  $V_{CC} = 3.3V \pm 10\%$ ,  $Temp = T_{MIN} \sim T_{MAX}$ , typical values are at  $V_{CC} = +3.3V$ ,  $Temp = 25^\circ C$ )

## SUPPLY CURRENT

PARAMETER	SYMBOL	CONDITION	MIN	TYP	MAX	UNIT
Supply Current	$I_{CC}$	DI=0 or VCC		240	400	$\mu A$

## ESD PROTECTION

PARAMETER	SYMBOL	CONDITION	MIN	TYP	MAX	UNIT
A, B, Y, Z		HBM		$\pm 16$		kV
Other ports		HBM		$\pm 6$		kV

## DRIVER SWITCHING CHARACTERISTICS

PARAMETER	SYMBOL	CONDITION	MIN	TYP	MAX	UNIT
Driver Propagation Delay, Low-to-High Level	$t_{DPLH}$	$R_{DIFF} = 54 \Omega$ , $C_{L1} = C_{L2} = 100pF$ ( <a href="#">Figure3</a> & <a href="#">Figure4</a> )		15	35	ns

PARAMETER	SYMBOL	CONDITION	MIN	TYP	MAX	UNIT
Driver Propagation Delay, High-to-Low Level	$t_{DPLH}$	$R_{DIFF}=54\ \Omega$ , $C_{L1}=C_{L2}=100\text{pF}$ (Figure3 & Figure4)		15	35	ns
$ t_{DPLH} - t_{DPHL} $	$t_{SKEW1}$			7	10	ns
Rising time /Falling time	$t_{DR}, t_{DF}$				10	25

### RECEIVER SWITCHING CHARACTERISTICS

PARAMETER	SYMBOL	CONDITION	MIN	TYP	MAX	UNIT
Receiver Propagation Delay, Low-to-High Level	$t_{RPLH}$	<a href="#">Figure 5 &amp; Figure 6</a> $V_{ID} \geq 2.0\text{V}$ ; Rising and falling edge time $V_{ID} \leq 15\text{ns}$	20	60	90	ns
Receiver Propagation Delay, High-to-Low Level	$t_{RPHL}$		20	60	90	ns
$ t_{RPLH} - t_{RPHL} $	$t_{SKEW2}$			7	10	ns

### FUNCTION TABLE

**Driver Function**

INPUT	OUTPUT	
DI	Y	Z
1	H	L
0	L	H
-	-	-

**Receiver Function**

INPUT	OUTPUT
A-B	RO
$\geq +200\text{mV}$	H
$\leq -200\text{mV}$	L
Open/Short	H

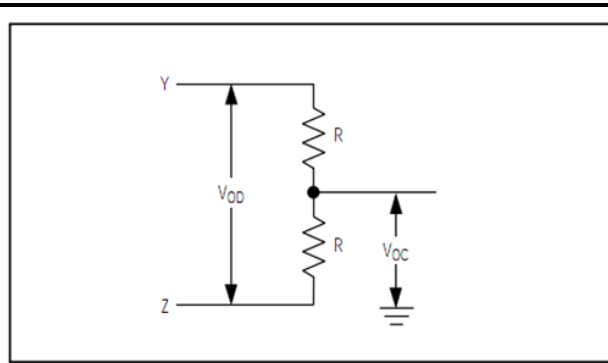
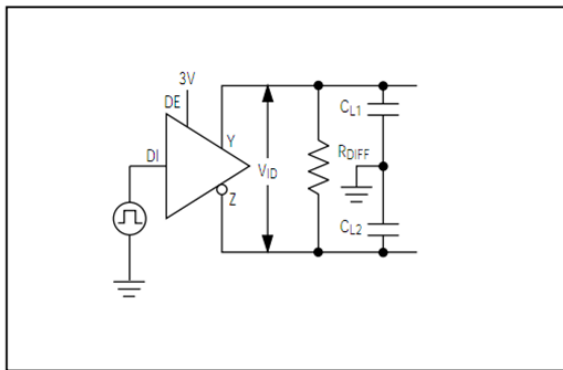
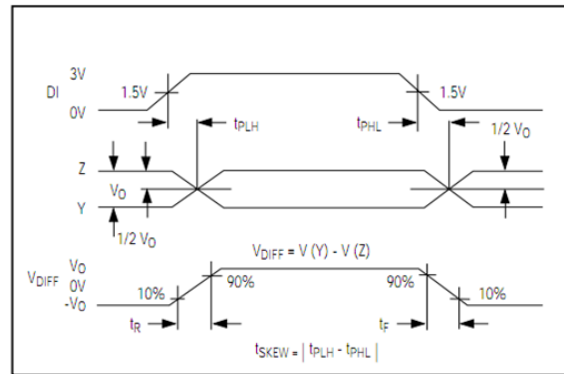
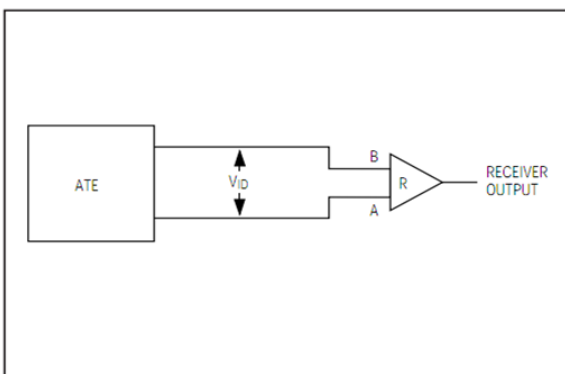
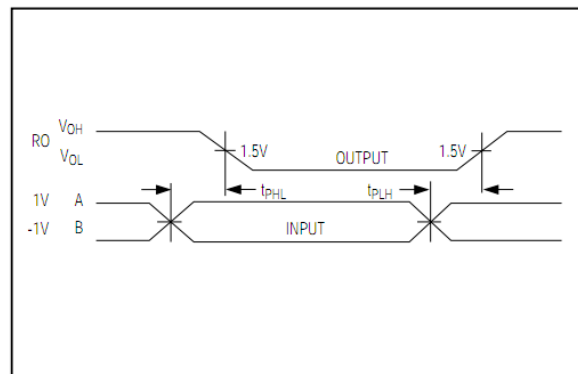
**TEST CIRCUIT**

**Figure 2 Driver DC test load**

**Figure 3 Driver timing test circuit**

**Figure 4 Drive propagation delay**

**Figure 5 Receiver propagation delay test circuit**

**Figure 6 Receiver propagation delay timing**

## ADDITIONAL DESCRIPTION

### 1 Sketch

MAX3490E is a full -duplex high-speed transceiver for RS-485/RS-422 communication, which includes a driver and a receiver. It has failure safety, over-voltage protection and over-current protection. MAX3490E realizes error-free data transmission up to 14Mbps.

### 2 Allowing up to 256 transceivers on the bus

The input impedance of the standard RS485 receiver is  $12k\Omega$  (1 unit load), and the standard driver can drive up to 32 unit loads. The receiver of MAX3490E transceiver has  $1/8$  unit load input impedance ( $96k\Omega$ ), which allows up to 256 transceivers to be connected on the same communication bus in parallel. These devices can be combined arbitrarily or with other RS485 transceivers. Any combination of these devices and/or other RS-485 transceivers with a total of 32 unit loads or less can be connected to the line.

### 3 Driver output protection

By means of over-current and over-voltage protection mechanism, it can prevent excessive output current and power dissipation caused by faults or by bus contention, and fast short-circuit protection can be provided in the whole common mode voltage range (refer to typical working characteristics).

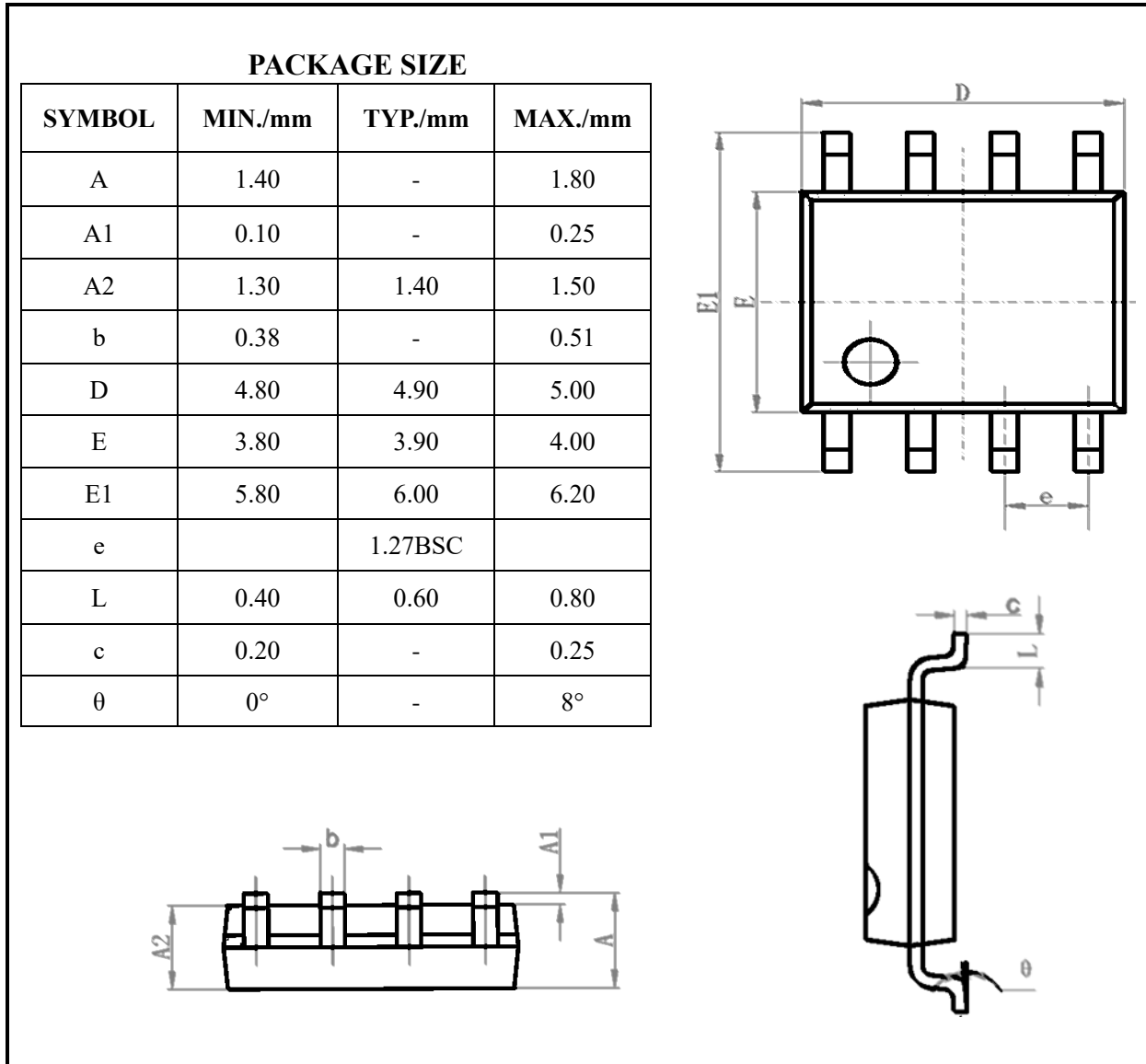
**SOP8 DIMENSIONS**

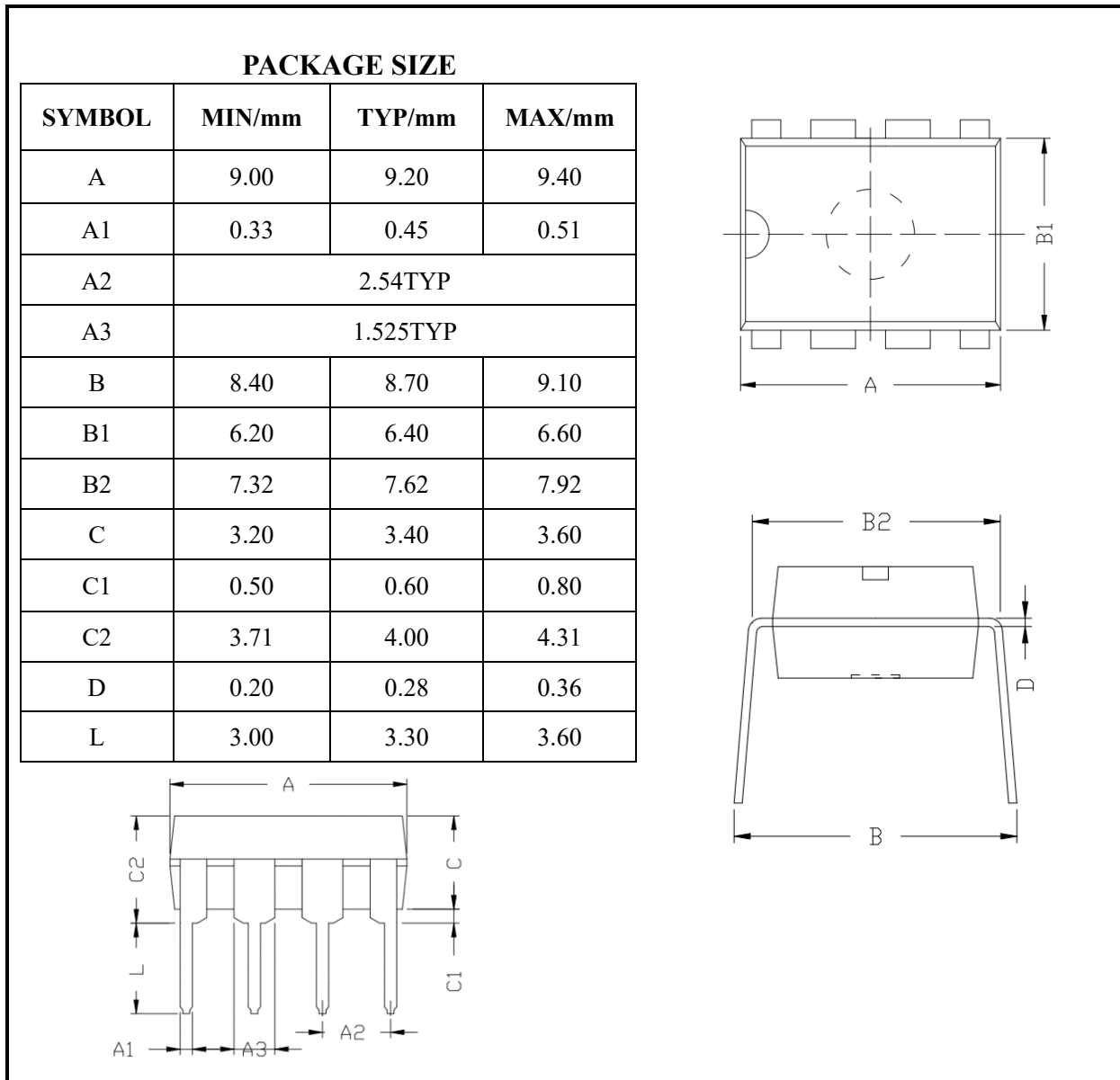

**DIP8 DIMENSIONS**

**MSOP8/8 $\mu$ MAX/VSSOP8 DIMENSIONS**

PACKAGE SIZE			
SYMBOL	MIN./mm	TYP./mm	MAX./mm
A	2.90	3.0	3.10
A1	0.28		0.35
A2	0.65TYP		
A3	0.375TYP		
B	2.90	3.0	3.10
B1	4.70		5.10
B2	0.45		0.75
C	0.75		0.95
C1			1.10
C2	0.328 TYP		
C3	0.152		
C4	0.15		0.23
H	0.00		0.09
$\theta$	12°TYP		

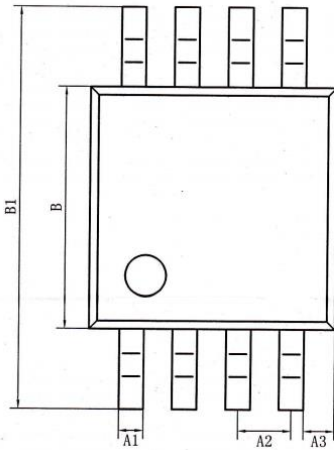
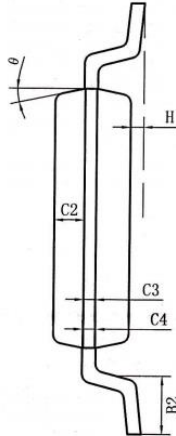
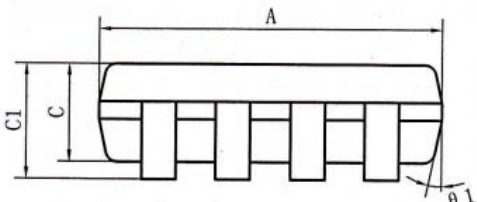

**ORDERING INFORMATION**

TYPE NUMBER	PACKAGE	PACKAGING
MAX3490EESA+T	SOP8	Tape and reel
MAX3490EEPA	DIP8	Tube
MAX3490EEUA	MSOP8/VSSOP8/8 $\mu$ MAX	Tape and reel

Braided packing is 2500 pieces/disc. DIP8 is packed with 50 pieces/tube.

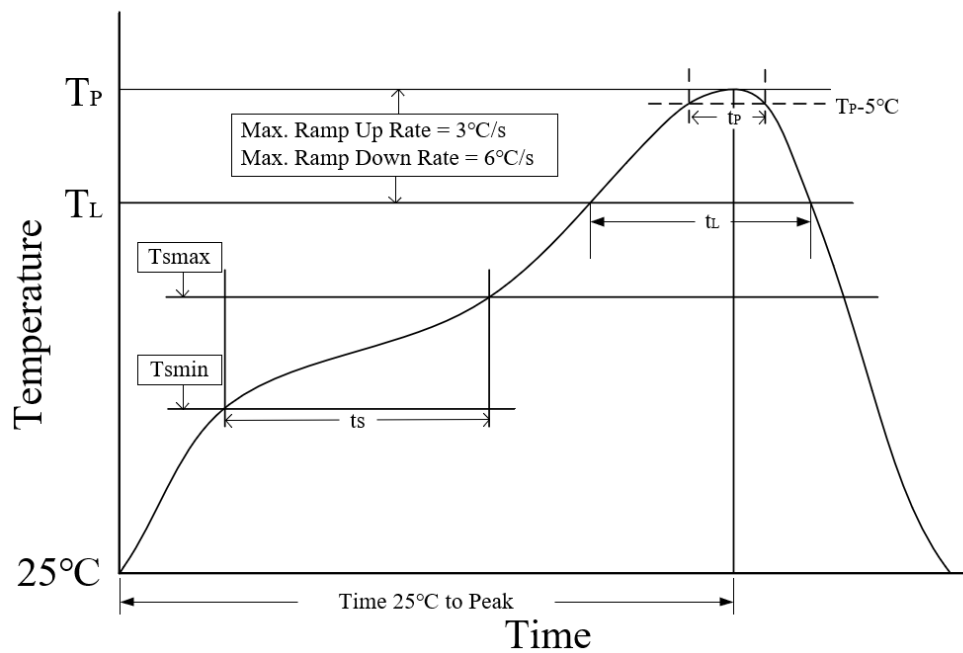
## REFLOW SOLDERING



Parameter	Lead-free soldering conditions
Ave ramp up rate ( $T_L$ to $T_P$ )	3 °C/second max
Preheat time $t_s$ ( $T_{smin}=150^\circ\text{C}$ to $T_{smax}=200^\circ\text{C}$ )	60-120 seconds
Melting time $t_L$ ( $T_L=217^\circ\text{C}$ )	60-150 seconds
Peak temp $T_P$	260-265 °C
5°C below peak temperature $t_p$	30 seconds
Ave cooling rate ( $T_P$ to $T_L$ )	6 °C/second max
Normal temperature 25°C to peak temperature $T_P$ time	8 minutes max

## X-ON Electronics

Largest Supplier of Electrical and Electronic Components

*Click to view similar products for [RS-422/RS-485 Interface IC](#) category:*

*Click to view products by [Tokmas](#) manufacturer:*

Other Similar products are found below :

[SP3494CN-L/TR](#) [ISL4486IBZ-T](#) [ISL4491EIB](#) [ISL4491EIBZ-T](#) [ISL81483IB](#) [ISL83086EIB](#) [ISL83088EIB](#) [ISL83488IB](#) [ISL8483EIB](#)  
[ISL8487EIB](#) [ISL8489EIB](#) [ISL8491IP](#) [ADM489AN](#) [CA-IF4820HM](#) [CS48505M](#) [CS485S](#) [CS817x22HS](#) [MAX485ESA-MS](#) [MAX3085](#)  
[ADM3485EARZ](#) [SP3485EEN](#) [TP3485ES8](#) [MAX3485ESA](#) [ST3485EBDR](#) [ADM485ARZ](#) [CA-IF4820HD](#) [CA-IF1042S-Q1](#) [CA-IF1021D-Q1](#)  
[CS48520D](#) [SN65HVD78EIMM/TR](#) [HGX3085ECMM/TR](#) [SP3085EIMM/TR](#) [HGX3085EIMM/TR](#) [SN65HVD72EIMM/TR](#) [HGX485EIN](#)  
[RS1905XK](#) [SIT1044QTK](#) [THVD1420DR](#) [MAX3490EESA+T](#) [UM3483EESA](#) [HD588L](#) [HD568N](#) [HD688ADR](#) [CA-IS3080WX](#) [CA-](#)  
[IS3086WX](#) [CS817x20HS](#) [CA-IF1044S-Q1](#) [CA-IF4820FS](#) [CA-IF4850HS](#) [XR3077XID-F](#)