

FEATURES

- Fully compatible with the ISO 11898 standard
- Thermally protected
- $\pm 70V$ BUS protection
- Driver (TXD) and standby bus (BUS) dominant timeout function
- Low-power standby mode with wake-up function
- TJA1042T can be interfaced directly to microcontrollers with supply voltages from 3V to 5V
- Undervoltage protection on VCC and VIO power supply pins
- Timing guaranteed for data rates up to 5 Mbit/s in the (CAN FD) fast phase
- The typical loop delay from TXD to RXD is less than 100ns
- Very low ElectroMagnetic Emission (EME)
- Unpowered nodes do not interfere with the bus
- Provide DFN3*3-8, small outline, leadless package

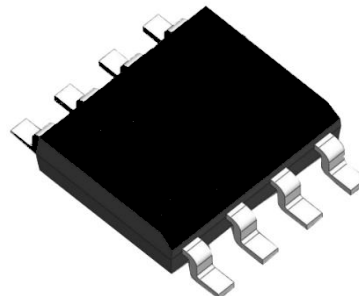

SOP-8

DESCRIPTION

| PARAMETER | SYMBOL | CONDITION | MIN. | MAX. | UNIT |
|-----------------------------------|--------------------|-------------------------|------|------|-------|
| Supply voltage | VCC | | 4.5 | 5.5 | V |
| Maximum transmission rate | 1/t _{bit} | Non-return to zero code | 5 | | Mbaud |
| CANH/CANL input or output voltage | V _{can} | | -70 | +70 | V |
| Bus differential voltage | V _{diff} | | 1.5 | 3.0 | V |
| Virtual junction temperature | T _j | | -40 | 150 | °C |

PIN CONFIGURATION

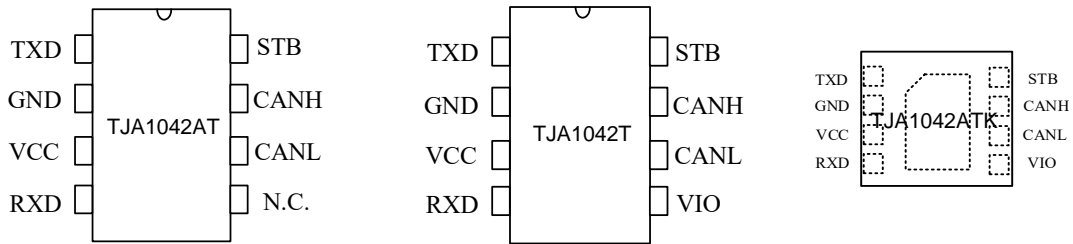

PIN DESCRIPTION

| PIN | SYMBOL | DESCRIPTION |
|-----|--------|---|
| 1 | TXD | transmit data input |
| 2 | GND | ground |
| 3 | VCC | supply voltage |
| 4 | RXD | receive data output; reads out data from the bus lines |
| 5 | VIO | transceiver I/O level conversion power supply voltage (TJA1042T version) |
| 5 | N.C. | no connection (TJA1042T version) |
| 6 | CANL | LOW-level CAN-bus line |
| 7 | CANH | HIGH-level CAN-bus line |
| 8 | STB | standby mode control input, low level is high speed mode |

LIMITING VALUES

| PARAMETER | SYMBOL | VALUE | UNIT |
|------------------------------------|--------------------|---------|------|
| Supply voltage | VCC | -0.3~7 | V |
| MCU side port | TXD, RXD, STB, VIO | -0.3~7 | V |
| Bus side input voltage | CANL, CANH | -70~70 | V |
| Bus differential breakdown voltage | $V_{CANH-CANL}$ | -27~27 | V |
| Storage temperature | T_{stg} | -55~150 | °C |
| Virtual junction temperature | T_j | -40~150 | °C |

The maximum limit parameters mean that exceeding these values may cause irreversible damage to the device. Under these conditions, it is not conducive to the normal operation of the device. The continuous operation of the device at the maximum allowable rating may affect the reliability of the device. The reference point for all voltages is ground.

INTERNAL CIRCUIT BLOCK DIAGRAM

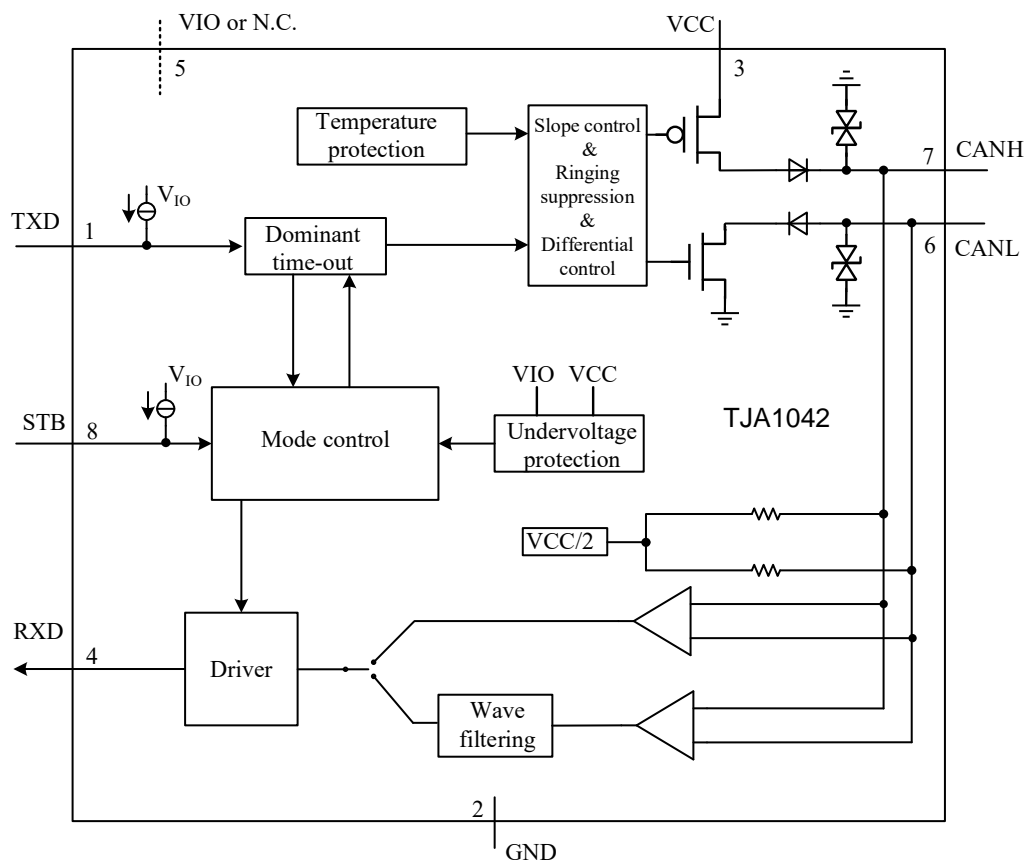

DRIVER ELECTRICAL CHARACTERISTICS

| PARAMETER | SYMBOL | CONDITION | MIN. | TYP. | MAX. | UNIT |
|--|------------------|---|--------------------|--------------------|--------------------|------|
| CANH dominant output voltage | $V_{OH(D)}$ | Normal mode, TXD=0V, $R_L=50\Omega$ to 65Ω | 2.75 | 3.5 | 4.5 | V |
| CANL dominant output voltage | $V_{OL(D)}$ | | 0.5 | 1.5 | 2.25 | V |
| Bus dominant differential output voltage | $V_{OD(D)}$ | Normal mode, TXD=0V, $R_L=50\Omega$ to 65Ω | 1.5 | | 3 | V |
| | | Normal mode, TXD=0V, $R_L=45\Omega$ to 70Ω | 1.4 | | 3.3 | V |
| | | Normal mode, TXD=0V, $R_L=2240\Omega$ | 1.5 | | 5 | V |
| Bus recessive output voltage | $V_{O(R)}$ | Normal mode, TXD=VIO, No load | 2 | 0.5V _{CC} | 3 | V |
| Bus recessive differential output voltage | $V_{OD(R)}$ | Normal mode, TXD=VIO, No load | -500 | | 50 | mV |
| Bus output voltage (Bus is biased to ground) | $V_{O(S)}$ | Standby mode, No load | -0.1 | | 0.1 | V |
| Bus differential output voltage (Bus is biased to ground) | $V_{OD(S)}$ | Standby mode, No load | -0.2 | | 0.2 | V |
| Transmitter dominant voltage symmetry | $V_{dom(TX)sym}$ | $V_{dom(TX)sym}=V_{CC}-$ CANH - CANL | -400 | | 400 | mV |
| Transmitter voltage symmetry | V_{TXsym} | $V_{TXsym}= CANH +$ CANL, $R_L=60\Omega$, $C_{SPLIT}=4.7nF$, $f_{TXD}=250kHz$, 1MHz, 2MHz Fig 5 | 0.9V _{CC} | | 1.1V _{CC} | V |
| Dominant-recessive common-mode output voltage difference | $V_{cm(step)}$ | Fig 3 , Fig 5 | -150 | | 150 | mV |

| PARAMETER | SYMBOL | CONDITION | MIN. | TYP. | MAX. | UNIT |
|---|----------------|---|------|------|------|------|
| Dominant-recessive common-mode peak-to-peak | $V_{cm(p-p)}$ | Fig 3 , Fig 5 | -300 | | 300 | mV |
| Dominant short-circuit output current | $I_{O(SC)DOM}$ | Normal mode, TXD=0V, CANH=-15V to 40V | -100 | -70 | -40 | mA |
| | | Normal mode, TXD=0V, CANL=-15V to 40V | 40 | 70 | 100 | mA |
| Recessive short-circuit output current | $I_{O(SC)REC}$ | Normal mode, TXD=VIO, CANH=CANL=-27V to 32V | -3 | | 3 | mA |

Unless otherwise stated, all typical values are measured at 25°C, supply voltage VCC=5V, VIO=5V (if applicable), $R_L=60\Omega$.

DRIVER SWITCHING CHARACTERISTICS

| PARAMETER | SYMBOL | CONDITION | MIN. | TYP. | MAX. | UNIT |
|--|---------------------|--|------|------|------|------|
| Propagation delay time, low-to-high level output | $t_{d(TXD-busdom)}$ | Normal mode, Fig 1 , Fig 4 | | 45 | | ns |
| Propagation delay time, high-to-low level output | $t_{d(TXD-busrec)}$ | Normal mode, Fig 1 , Fig 4 | | 55 | | ns |
| Differential output signal rise time | $t_{r(BUS)}$ | | | 45 | | ns |
| Differential output signal fall time | $t_{f(BUS)}$ | | | 45 | | ns |

Unless otherwise stated, all typical values are measured at 25°C, supply voltage VCC=5V, VIO=5V (if applicable), $R_L=60\Omega$.

RECEIVER ELECTRICAL CHARACTERISTICS

| PARAMETER | SYMBOL | CONDITION | MIN. | TYP. | MAX. | UNIT |
|---|------------------|---|------|------|------|------------|
| Receiver threshold voltage | $V_{th(RX)dif}$ | Normal mode, $-30V < V_{CM} < 30V$ | 0.5 | | 0.9 | V |
| | | Normal mode, $-12V < V_{CM} < 12V$ | 0.4 | | 1.15 | V |
| Receiver threshold voltage hysteresis range | $V_{hys(RX)dif}$ | Normal mode, $-30V < V_{CM} < 30V$ | 50 | 120 | 400 | mV |
| Receiver recessive voltage range | $V_{rec(RX)}$ | Normal mode, $-30V < V_{CM} < 30V$ | -3 | | 0.5 | V |
| | | Standby mode, $-12V < V_{CM} < 12V$ | -3 | | 0.4 | V |
| Receiver dominant voltage range | $V_{dom(RX)}$ | Normal mode, $-30V < V_{CM} < 30V$ | 0.9 | | 8 | V |
| | | Standby mode, $-12V < V_{CM} < 12V$ | 1.15 | | 8 | V |
| Bus leakage current | I_L | $V_{CC}=V_{IO}=0V$, CANH= CANL=5V | -10 | | 10 | μA |
| CANH, CANL input resistance | R_{IN} | $-2V \leq CANH \leq 7V$ $-2V \leq CANL \leq 7V$ | 9 | 15 | 28 | k Ω |
| CANH, CANL differential-input resistance | R_{ID} | $-2V \leq CANH \leq 7V$ $-2V \leq CANL \leq 7V$ | 19 | 30 | 52 | k Ω |
| CANH, CANL input resistance mismatch | ΔR_{IN} | $0V \leq CANH \leq 5V$ $0V \leq CANL \leq 5V$ | -2 | | 2 | % |
| CANH, CANL input capacitance to ground | C_{IN} | TXD=VIO | | 24 | | pF |
| CANH, CANL differential-input capacitance | C_{ID} | TXD=VIO | | 12 | | pF |
| Bus slew rate | SR | Bus differential voltage dominant to recessive edge | | | 70 | V/ μs |

Unless otherwise stated, all typical values are measured at 25°C, supply voltage $V_{CC}=5V$, $V_{IO}=5V$ (if applicable), $R_L=60\Omega$.

RECEIVER SWITCHING CHARACTERISTICS

| PARAMETER | SYMBOL | CONDITION | MIN. | TYP. | MAX. | UNIT |
|--|----------------------------|---|------|------|------|------|
| Propagation delay time, low-to-high level output | $t_{d(\text{busdom-RXD})}$ | Normal mode, Fig 1, Fig 4 | | 45 | | ns |
| Propagation delay time, high-to-low level output | $t_{d(\text{busrec-RXD})}$ | Normal mode, Fig 1, Fig 4 | | 45 | | ns |
| RXD signal rise time | $t_{r(\text{RXD})}$ | | | 8 | | ns |
| RXD signal fall time | $t_{f(\text{RXD})}$ | | | 8 | | ns |

Unless otherwise stated, all typical values are measured at 25°C, supply voltage VCC=5V, VIO=5V (if applicable), R_L=60Ω.

DEVICE SWITCHING CHARACTERISTICS

| PARAMETER | SYMBOL | CONDITION | MIN. | TYP. | MAX. | UNIT |
|--|------------------------------|---|------|------|------|------|
| Loop delay 1, TXD falling edge to RXD falling edge | t_{loop1} | Normal mode, Fig 1, Fig 4 | 40 | | 160 | ns |
| Loop delay 2, TXD rising edge to RXD rising edge | t_{loop2} | Normal mode, Fig 1, Fig 4 | 40 | | 175 | ns |
| Bit time of BUS output pin | $t_{\text{bit}(\text{BUS})}$ | $t_{\text{bit}(\text{TXD})}=500\text{ns}$ | 435 | | 530 | ns |
| | | $t_{\text{bit}(\text{TXD})}=200\text{ns}$ | 155 | | 210 | ns |
| Bit time of RXD output pin | $t_{\text{bit}(\text{RXD})}$ | $t_{\text{bit}(\text{TXD})}=500\text{ns}$ | 400 | | 550 | ns |
| | | $t_{\text{bit}(\text{TXD})}=200\text{ns}$ | 120 | | 220 | ns |
| Time difference between BUS and RXD output bits | Δt_{rec} | $\Delta t_{\text{rec}}=t_{\text{bit}(\text{RXD})}-t_{\text{bit}(\text{BUS});}$ $t_{\text{bit}(\text{TXD})}=500\text{ns}$ | -65 | | 40 | ns |
| | | $\Delta t_{\text{rec}}=t_{\text{bit}(\text{RXD})}-t_{\text{bit}(\text{BUS});}$ $t_{\text{bit}(\text{TXD})}=200\text{ns}$ | -45 | | 15 | ns |
| TXD dominant timeout | $t_{\text{dom_TXD}}$ | | 0.8 | 2 | 4 | ms |
| BUS dominant timeout | $t_{\text{dom_BUS}}$ | | 0.8 | 2 | 4 | ms |
| Enable time from standby mode to normal mode | t_{EN} | | | | 10 | μs |

| PARAMETER | SYMBOL | CONDITION | MIN. | TYP. | MAX. | UNIT |
|---------------------|------------|-----------|------|------|------|---------|
| Wake-up time of BUS | t_{WAKE} | | 0.5 | | 1.8 | μs |

Unless otherwise stated, all typical values are measured at 25°C, supply voltage $V_{CC}=5V$, $V_{IO}=5V$ (if applicable), $R_L=60\Omega$.

TXD PIN CHARACTERISTICS

| PARAMETER | SYMBOL | CONDITION | MIN. | TYP. | MAX. | UNIT |
|--------------------------------------|---------------|------------------------------------|-------------|------|--------------|---------|
| HIGH-level input current | $I_{IH}(TXD)$ | $TXD=V_{IO}$ | -5 | | 5 | μA |
| LOW-level input current | $I_{IL}(TXD)$ | $TXD=0V$ | -260 | -150 | -30 | μA |
| Leakage current of TXD without power | $I_{O(off)}$ | $V_{CC}=V_{IO}=0V$, $TXD=5.5V$ | -1 | | 1 | μA |
| HIGH-level input voltage | V_{IH} | TJA1042T | $0.7V_{IO}$ | | $V_{IO}+0.3$ | V |
| LOW-level input voltage | V_{IL} | TJA1042T | -0.3 | | $0.3V_{IO}$ | V |
| HIGH-level input voltage | V_{IH} | TJA1042AT | 2 | | $V_{CC}+0.3$ | V |
| LOW-level input voltage | V_{IL} | TJA1042AT | -0.3 | | 0.8 | V |
| Open voltage on TXD pin | TXD_O | | H | | | logic |

Unless otherwise stated, all typical values are measured at 25°C, supply voltage $V_{CC}=5V$, $V_{IO}=5V$ (if applicable), $R_L=60\Omega$.

STB PIN CHARACTERISTICS

| PARAMETER | SYMBOL | CONDITION | MIN. | TYP. | MAX. | UNIT |
|--------------------------------------|---------------|------------------------------------|-------------|------|--------------|---------|
| HIGH-level input current | $I_{IH}(STB)$ | $STB=V_{IO}$ | -2 | | 2 | μA |
| LOW-level input current | $I_{IL}(STB)$ | $STB=0V$ | -20 | | -2 | μA |
| Leakage current of STB without power | $I_{O(off)}$ | $V_{CC}=V_{IO}=0V$, $STB=5.5V$ | -1 | | 1 | μA |
| HIGH-level input voltage | V_{IH} | TJA1042T | $0.7V_{IO}$ | | $V_{IO}+0.3$ | V |
| LOW-level input voltage | V_{IL} | TJA1042T | -0.3 | | $0.3V_{IO}$ | V |

| PARAMETER | SYMBOL | CONDITION | MIN. | TYP. | MAX. | UNIT |
|--------------------------|------------------|-----------|------|------|--------------|-------|
| HIGH-level input voltage | V_{IH} | TJA1042AT | 2 | | $V_{CC}+0.3$ | V |
| LOW-level input voltage | V_{IL} | TJA1042AT | -0.3 | | 0.8 | V |
| Open voltage on STB pin | STB _o | | H | | | logic |

Unless otherwise stated, all typical values are measured at 25°C, supply voltage $V_{CC}=5V$, $V_{IO}=5V$ (if applicable), $R_L=60\Omega$.

RXD PIN CHARACTERISTICS

| PARAMETER | SYMBOL | CONDITION | MIN. | TYP. | MAX. | UNIT |
|--------------------------------------|---------------|--|------|------|------|---------|
| HIGH-level input current | $I_{OH}(RXD)$ | $V_{IO}=V_{CC}$, $RXD=V_{IO}-0.4V$ | -8 | -3 | -1 | mA |
| LOW-level input current | $I_{OL}(RXD)$ | $RXD=0.4V$, Bus dominant | 2 | 5 | 12 | mA |
| Leakage current of RXD without power | $I_{o(off)}$ | $V_{CC}=V_{IO}=0V$, $RXD=5.5V$ | -1 | | 1 | μA |

Unless otherwise stated, all typical values are measured at 25°C, supply voltage $V_{CC}=5V$, $V_{IO}=5V$ (if applicable), $R_L=60\Omega$.

SUPPLY CURRENT

| PARAMETER | SYMBOL | CONDITION | MIN. | TYP. | MAX. | UNIT | |
|--------------------|---------------|--|------|------|------|---------|---------|
| VCC supply current | I_{CC_D} | Normal mode, dominant | | 45 | 70 | mA | |
| | I_{CC_R} | Normal mode, recessive | | 5 | 10 | mA | |
| | I_{CC_STB} | Standby mode, $STB=TXD=V_{IO}$, (TJA1042T) | | | 0.5 | 5 | μA |
| | | Standby mode, $STB=TXD=V_{CC}$, (TJA1042AT) | | | 12 | 20 | μA |
| VIO supply current | I_{IO_D} | Normal mode, dominant | | 170 | 300 | μA | |
| VIO supply current | I_{IO_R} | Normal mode, recessive | | 15 | 30 | μA | |

| PARAMETER | SYMBOL | CONDITION | MIN. | TYP. | MAX. | UNIT |
|--------------------|---------------|------------------------------|------|------|------|---------------|
| VIO supply current | I_{IO_STB} | Standby mode, STB=TXD=VIO | | 10 | 17 | μA |

Unless otherwise stated, all typical values are measured at 25°C, supply voltage VCC=5V, VIO=5V (if applicable), $R_L=60\Omega$.

OVER TEMPERATURE PROTECTION

| PARAMETER | SYMBOL | CONDITION | MIN. | TYP. | MAX. | UNIT |
|-------------------------------|-------------|-----------|------|------|------|--------------------|
| Shutdown junction temperature | $T_{j(sd)}$ | | | 190 | | $^{\circ}\text{C}$ |

Unless otherwise stated, all typical values are measured at 25°C, supply voltage VCC=5V, VIO=5V (if applicable), $R_L=60\Omega$.

UNDERVOLTAGE PROTECTION

| PARAMETER | SYMBOL | CONDITION | MIN. | TYP. | MAX. | UNIT |
|-----------------------------|----------------|-----------|------|------|------|------|
| VCC undervoltage protection | V_{uvd_VCC} | | 3.7 | 4 | 4.3 | V |
| VIO undervoltage protection | V_{uvd_VIO} | | 1.7 | 2 | 2.3 | V |

Unless otherwise stated, all typical values are measured at 25°C, supply voltage VCC=5V, VIO=5V (if applicable), $R_L=60\Omega$.

ESD PERFORMANCE

| PARAMETER | SYMBOL | CONDITION | MIN. | TYP. | MAX. | UNIT |
|---|----------------|---|------|------|------|------|
| CAN bus pin contact discharge model (IEC) | V_{ESD_IEC} | IEC 61000-4-2: Contact discharge (CANH, CANL) | -4 | | +4 | kV |
| Human body model (HBM) | V_{ESD_HBM} | All ports | -8 | | +8 | kV |
| Charged device model (CDM) | V_{ESD_CDM} | | -750 | | +750 | V |
| Machine model (MM) | V_{ESD_MM} | | -300 | | +300 | V |

FUNCTION TABLE
Table1. CAN TRANSCEIVER TRUTH TABLE

| TXD ⁽¹⁾ | STB ⁽¹⁾ | CANH ⁽¹⁾ | CANL ⁽¹⁾ | BUS STATE | RXD ⁽¹⁾ |
|--------------------|--------------------|---------------------|---------------------|-----------|--------------------|
| L | L | H | L | Dominate | L |
| H or Open | L | 0.5VCC | 0.5VCC | Recessive | H |
| X | H or Open | GND | GND | Recessive | H |

(1) H=high level; L=low level; X=irrelevant.

Table 2. RECEIVER FUNCTION TABLE

| OPERATING MODE | $V_{ID}=CANH-CANL$ | BUS STATE | RXD ⁽¹⁾ |
|----------------|------------------------|-----------|--------------------|
| Normal mode | $V_{ID} \geq 0.9V$ | Dominate | L |
| | $0.5 < V_{ID} < 0.9V$ | ? | ? |
| | $V_{ID} \leq 0.5V$ | Recessive | H |
| Standby mode | $V_{ID} \geq 1.15V$ | Dominate | L |
| | $0.4 < V_{ID} < 1.15V$ | ? | ? |
| | $V_{ID} \leq 0.4V$ | Recessive | H |

(1) H=high level; L=low level; ?=uncertain.

Table 3. UNDERVOLTAGE PROTECTION STATUS TABLE

| VCC | VIO ⁽¹⁾ | BUS STATE | BUS OUTPUT ⁽²⁾ | RXD ⁽²⁾ |
|----------------------|----------------------|------------------|---------------------------|--------------------|
| $VCC > V_{uvd_VCC}$ | $VIO > V_{uvd_VIO}$ | Normal | According to STB and TXD | Follow the bus |
| $VCC < V_{uvd_VCC}$ | $VIO > V_{uvd_VIO}$ | Protected status | GND | H |
| $VCC > V_{uvd_VCC}$ | $VIO < V_{uvd_VIO}$ | Protected status | Z | H |
| $VCC < V_{uvd_VCC}$ | $VIO < V_{uvd_VIO}$ | Protected status | Z | H |

(1) TJA1042T version only;

(2) H=high level; Z=high ohmic.

TIMING WAVEFORM

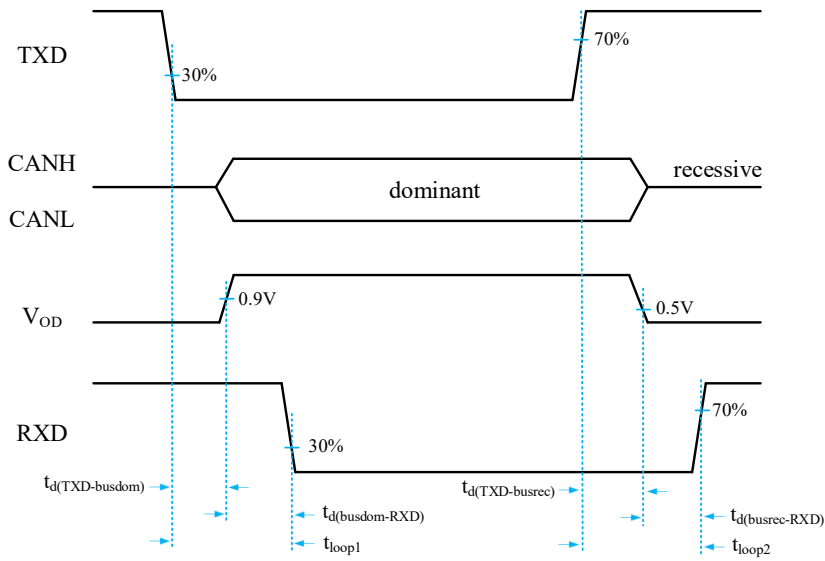

Fig 1 Transceiver transmission delay

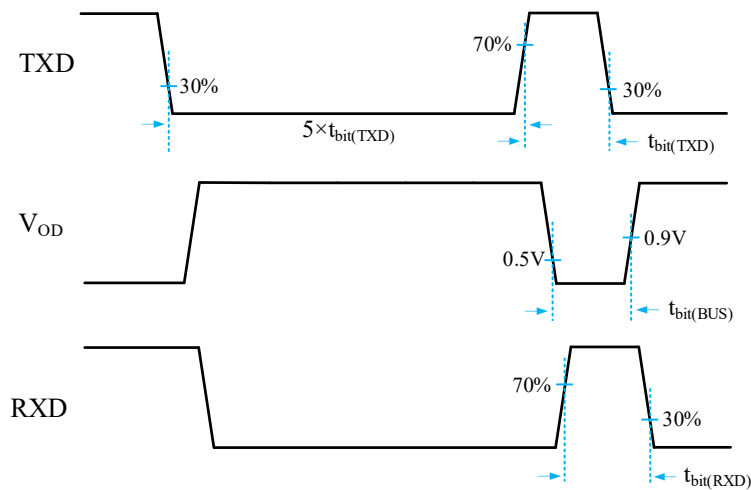

Fig 2 t_{bit} delay

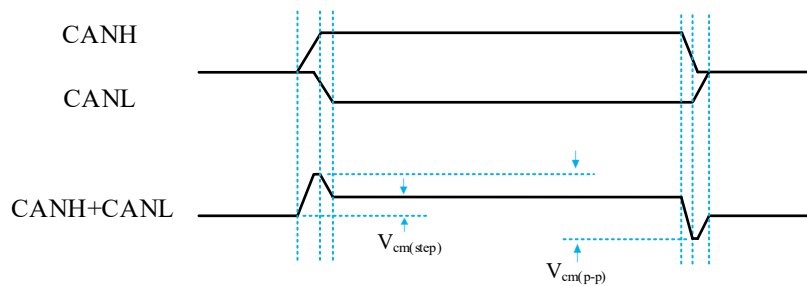

Fig 3 Bus common-mode voltage (SAE 1939-14)

TEST CIRCUIT

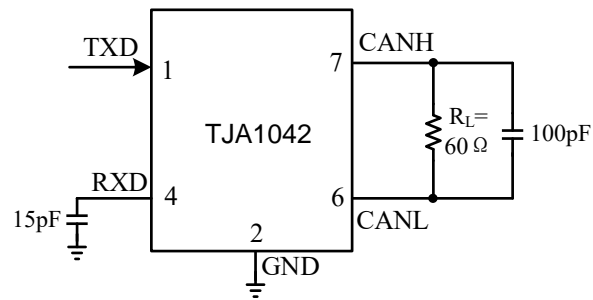

Fig 4 Transceiver timing sequence test circuit

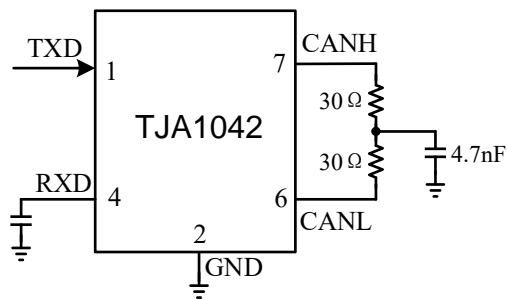

Fig 5 Transceiver bus symmetry test circuit

TYPICAL APPLICATION DIAGRAM

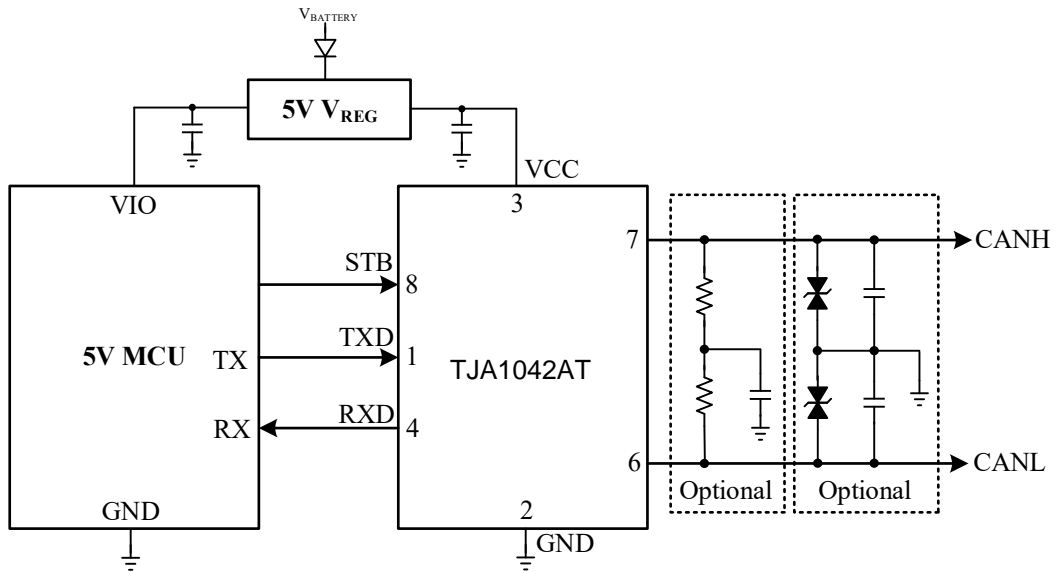

Fig 6 TJA1042AT and 5V MCU typical application diagram

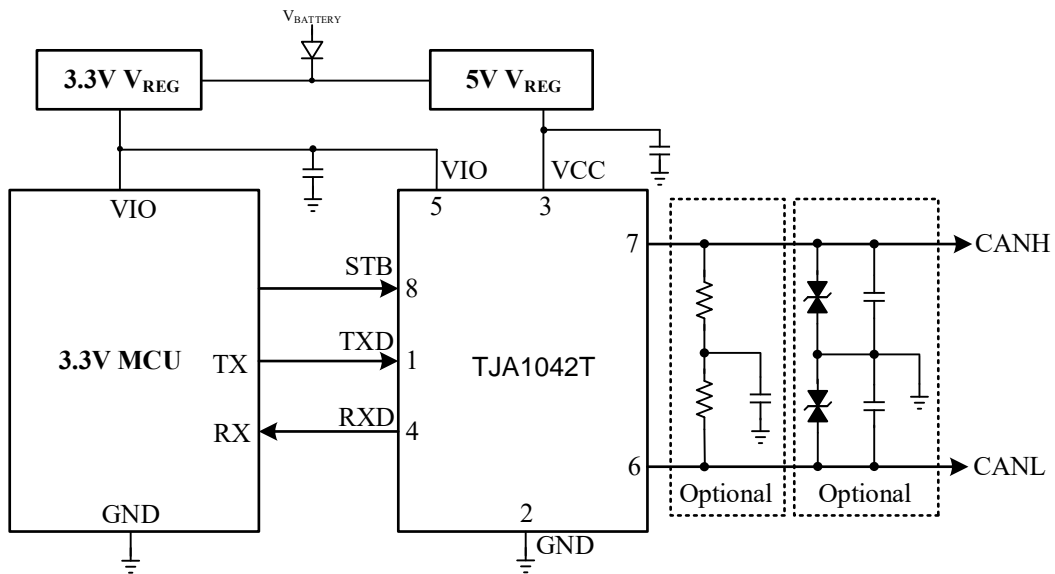

Fig 7 TJA1042T and 3.3V MCU typical application diagram

ADDITIONAL DESCRIPTION

1 Sketch

TJA1042 is an interface chip applied between the CAN protocol controller and the physical bus. It can be used for in-vehicle, industrial control and other fields. It supports 5Mbps flexible data rate (CAN FD) and has the ability to transmit differential signals between the bus and the CAN protocol controller. Fully compatible with ISO 11898 standard.

2 Short-circuit protection

A current-limiting circuit protects the transmitter output stage from damage caused by accidental short-circuit to either positive or negative supply voltage, although power dissipation increases during this fault condition.

3 Over temperature protection

The output drivers are protected against over-temperature conditions. If the virtual junction temperature exceeds the shutdown junction temperature $T_{j(sd)}$, the output drivers will be disabled until the virtual junction temperature becomes lower than $T_{j(sd)}$ and TXD becomes recessive again.

By including the TXD condition, the occurrence of output driver oscillation due to temperature drifts is avoided.

4 Undervoltage protection

The TJA1042 power supply pin has an undervoltage detection function, which can put the device in a protected mode. This protects the bus when VCC is lower than V_{uvd_VCC} or VIO is lower than V_{uvd_VIO} .

5 Control mode

The TJA1042 provides two modes of operation which are selectable via pin STB: High-speed mode and standby mode.

High-speed mode is normal working mode, by connecting STB to ground to set the TJA1042 to high-speed mode. In this mode the transceiver is able to transmit and receive data via the bus lines CANH and CANL. The differential receiver converts the analog data on the bus lines into digital data which is output to pin RXD via the multiplexer (MUX).

Set pin STB to high level to activate low power standby mode. CAN driver and receiver are turned off to save system power consumption. A high level on the pin STB activates this low-power receiver and wake-up filter, and pin RXD becomes low once the low-power differential comparator detects that the dominant bus level of the T_{WAKE} is exceeded. (In TJA1042T, when the VCC is undervoltage or the VCC is open, the low-power receiver can still detect dominant and recessive level on the bus as long as the VIO is powered properly.)

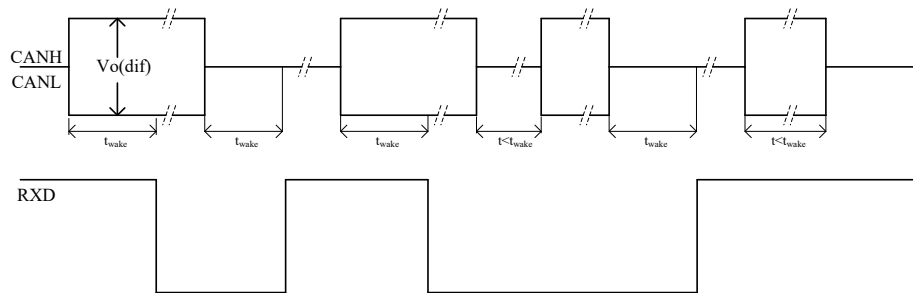

Fig 8 Wake-up timing

6 TXD dominant time-out function

A 'TXD dominant time-out' timer circuit prevents the bus lines from being driven to a permanent dominant state (blocking all network communication) if pin TXD is forced permanently LOW by a hardware and/or software application failure. The timer is triggered by a falling edge on pin TXD.

If the duration of the LOW level on pin TXD exceeds the internal timer value ($t_{\text{dom_TXD}}$), the transmitter is disabled, driving the bus lines into a recessive state. The timer is reset by a rising edge on pin TXD.

In standby mode, the pin RXD is forced to high if the bus becomes dominant and lasts longer than ($t_{\text{dom_BUS}}$), which can prevent permanent wakeup due to a short circuit in the bus or the failure of another node on the network. It can be reset when the bus changes from dominant to recessive.

SOP8 DIMENSIONS
PACKAGE SIZE

| SYMBOL | MIN./mm | TYP./mm | MAX./mm |
|----------|---------|---------|---------|
| A | 1.40 | - | 1.80 |
| A1 | 0.10 | - | 0.25 |
| A2 | 1.30 | 1.40 | 1.50 |
| A3 | 0.60 | 0.65 | 0.70 |
| b | 0.38 | - | 0.51 |
| D | 4.80 | 4.90 | 5.00 |
| E | 5.80 | 6.00 | 6.20 |
| E1 | 3.80 | 3.90 | 4.00 |
| e | 1.27BSC | | |
| L | 0.40 | 0.60 | 0.80 |
| L1 | 1.05REF | | |
| c | 0.20 | - | 0.25 |
| θ | 0° | - | 8° |

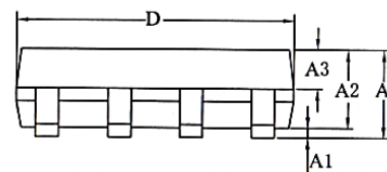
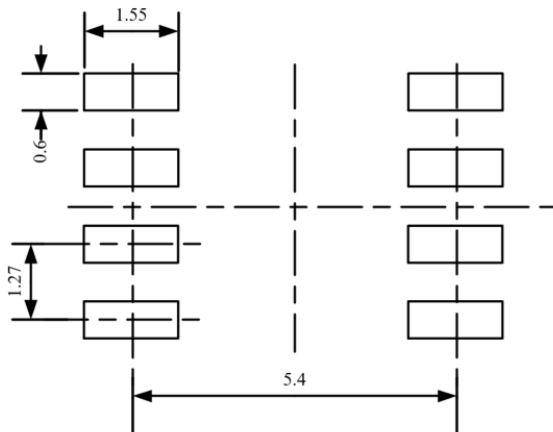
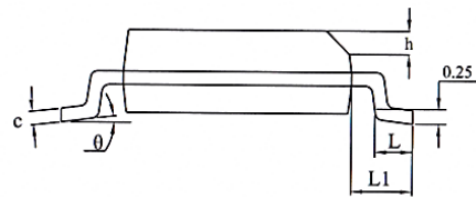
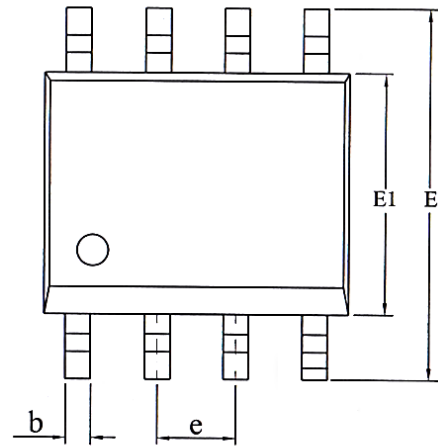

LAND PATTERN EXAMPLE (Unit: mm)

DFN3*3-8 DIMENSIONS
PACKAGE SIZE

| SYMBOL | MIN/mm | TYP /mm | MAX/mm |
|--------|-----------|---------|--------|
| A | 0.70 | 0.75 | 0.80 |
| A1 | 0 | 0.02 | 0.05 |
| A3 | 0.203 REF | | |
| D | 2.90 | 3.00 | 3.10 |
| E | 2.90 | 3.00 | 3.10 |
| D2 | 2.05 | 2.15 | 2.25 |
| Nd | 1.95BSC | | |
| E2 | 1.10 | 1.20 | 1.30 |
| b | 0.25 | 0.30 | 0.35 |
| e | 0.65 TYP | | |
| k | 0.50REF | | |
| L | 0.35 | 0.4 | 0.45 |
| h | 0.20 | 0.25 | 0.30 |

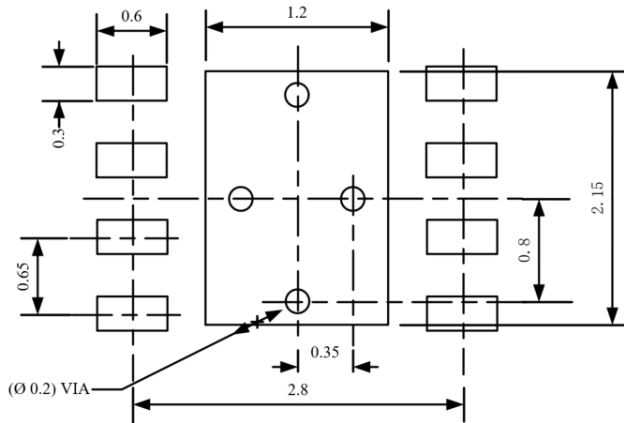
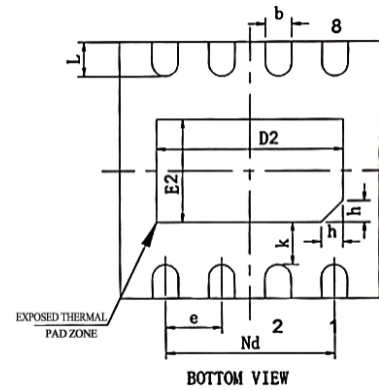
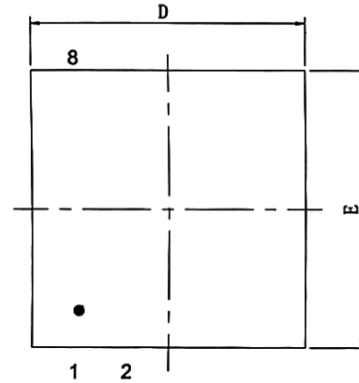

LAND PATTERN EXAMPLE (Unit: mm)

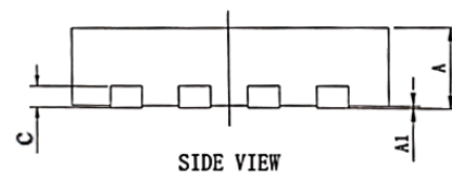

TAPE AND REEL INFORMATION

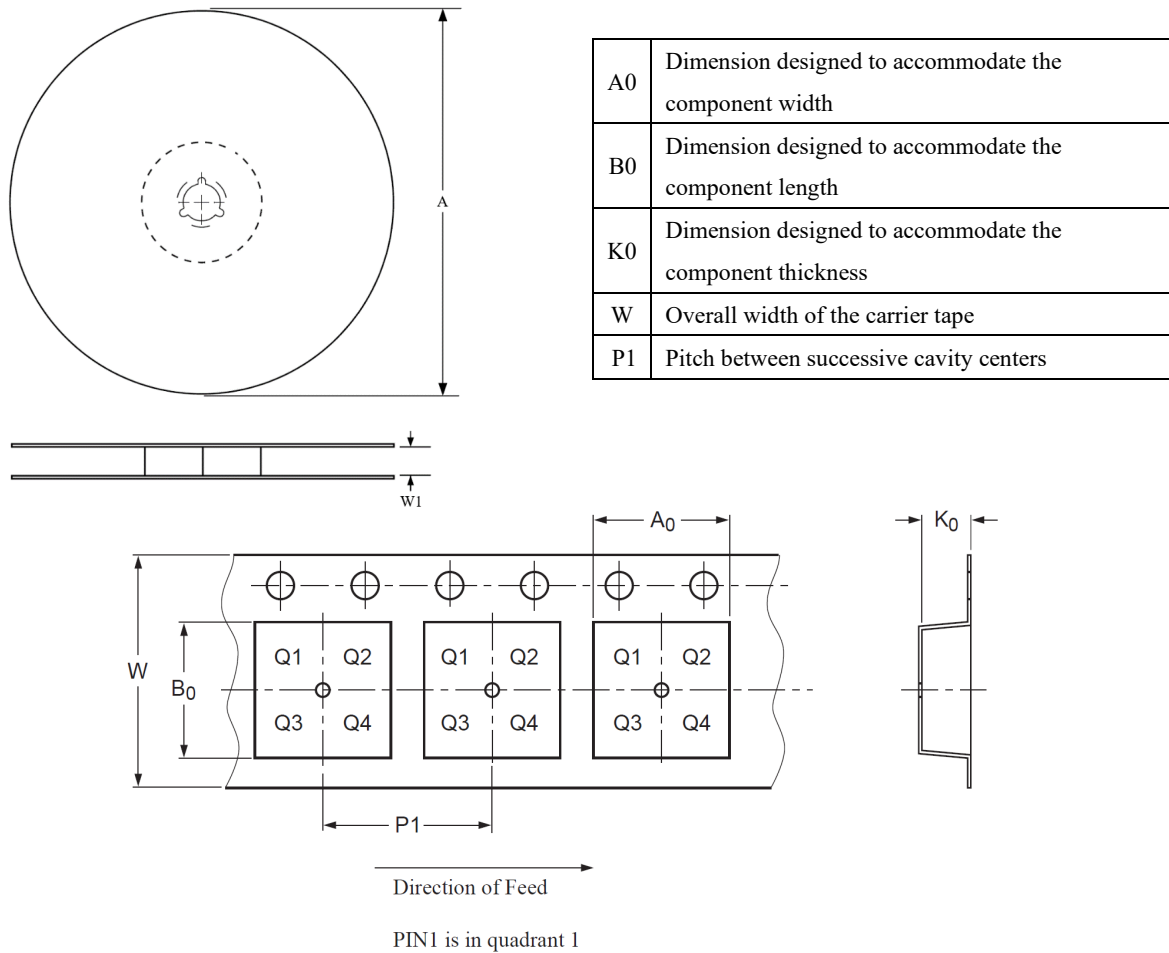

| Package Type | Reel Diameter A (mm) | Tape Width W1 (mm) | A0 (mm) | B0 (mm) | K0 (mm) | P1 (mm) | W (mm) |
|--------------|----------------------|--------------------|----------|-----------|----------|----------|-----------|
| SOP8 | 330±1 | 12.4 | 6.60±0.1 | 5.30±0.10 | 1.90±0.1 | 8.00±0.1 | 12.00±0.1 |
| DFN3*3-8 | 329±1 | 12.4 | 3.30±0.1 | 3.30±0.1 | 1.10±0.1 | 8.00±0.1 | 12.00±0.3 |

ORDERING INFORMATION

| TYPE NUMBER | PACKAGE | PACKING |
|-------------|---|---------------|
| TJA1042AT | SOP8 | Tape and reel |
| TJA1042T | SOP8 | Tape and reel |
| TJA1042ATK | DFN3*3-8, small shape, no leads, 8 terminals | Tape and reel |

SOP8 is packed with 2500 pieces/disc in braided packaging. Leadless DFN3*3-8 is packed with 6000 pieces/disc in braided packaging.

REFLOW SOLDERING

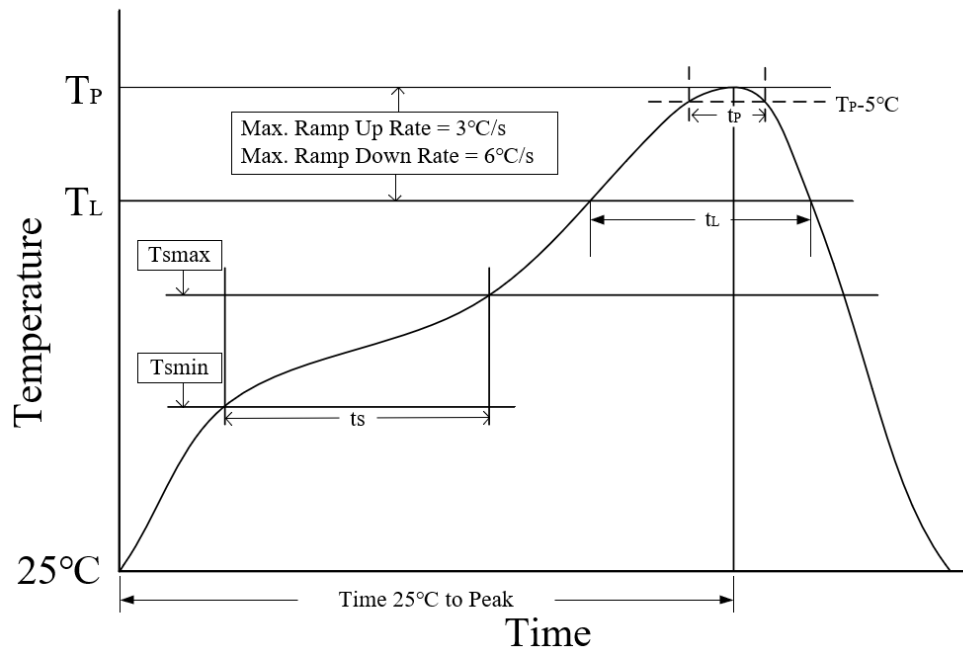

| Parameter | Lead-free soldering conditions |
|--|--------------------------------|
| Ave ramp up rate (T_L to T_P) | $3^\circ\text{C/second max}$ |
| Preheat time t_s ($T_{smin}=150^\circ\text{C}$ to $T_{smax}=200^\circ\text{C}$) | 60-120 seconds |
| Melting time t_L ($T_L=217^\circ\text{C}$) | 60-150 seconds |
| Peak temp T_P | $260-265^\circ\text{C}$ |
| 5°C below peak temperature t_p | 30 seconds |
| Ave cooling rate (T_P to T_L) | $6^\circ\text{C/second max}$ |
| Normal temperature 25°C to peak temperature T_P time | 8 minutes max |

X-ON Electronics

Largest Supplier of Electrical and Electronic Components

Click to view similar products for [CAN Interface IC](#) category:

Click to view products by [Tokmas](#) manufacturer:

Other Similar products are found below :

[PCA82C250T/N4](#) [TLE7251VLE](#) [SIT1051AT/3](#) [TJA1042T](#) [TJA1044T](#) [TJA1040T](#) [TJA1051T/3](#) [TPT1042V-SO1R-S](#) [SCM3425ASA](#)
[NCA1042-DSPR](#) [SIT1057QTK/3](#) [SIT1042AQT/3](#) [SIT1051AQT/3](#) [SIT1044QTK/3](#) [MCP2515-I](#) [TJA1051T](#) [PCA82C251T](#) [MAX3051ESA](#)
[SN65HVD230DR](#) [UM3608QA](#) [CA-IF1042VS-Q1](#) [CA-IF1044VS-Q1](#) [HMT1050T](#) [HMT1040T](#) [HGA82C251M/TR](#) [TJA1040M/TR](#)
[HG65HVD230M/TR](#) [TJA1042M-3/TR](#) [PCA82C251M/TR](#) [TDA51SCANHC](#) [TJA1044GT/1](#) [TJA1055T/3/1](#) [SIT1042AQT/3](#) [SIT1051AT](#)
[SIT1044QT/3](#) [SIT1057QT](#) [SIT1042QT](#) [SIT1051QT](#) [SIT1057QT/3](#) [SIT1051AQT/E](#) [SIT1057T/3](#) [SIT1043QTK](#) [SIT1042AT](#) [SIT1042AT/3](#)
[SIT1043QT](#) [SIT1042ATK/3](#) [SIT1057TK/3](#) [SL1040S](#) [MCP2561-HMF](#) [MCP2510-E/P](#)