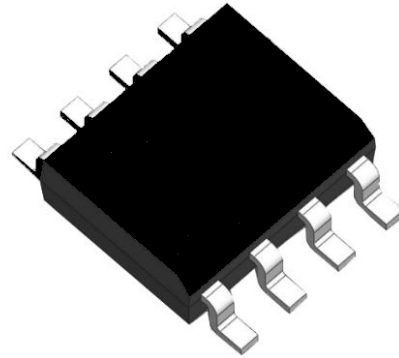


## FEATURES

- Fully compatible with ISO 11898-2:2016/SAE J2284-1~SAE J2284-5
- AEC-Q100 qualified
- Thermally protected
- $\pm 40V$  BUS protection
- Transmit Data (TXD) dominant time-out function
- Silent receive mode
- TJA1057GT/3J I/O can be interfaced directly to microcontrollers with supply voltages from 3V to 5V
- Undervoltage protection on VCC and VIO power supply pins
- Timing guaranteed for data rates up to 5 Mbps in the (CAN FD) fast phase
- Very low ElectroMagnetic Emission (EME)
- Unpowered nodes do not interfere with the bus
- The typical loop delay from TXD to RXD is less than 100ns
- Provide SOP8 and DFN3\*3-8 package



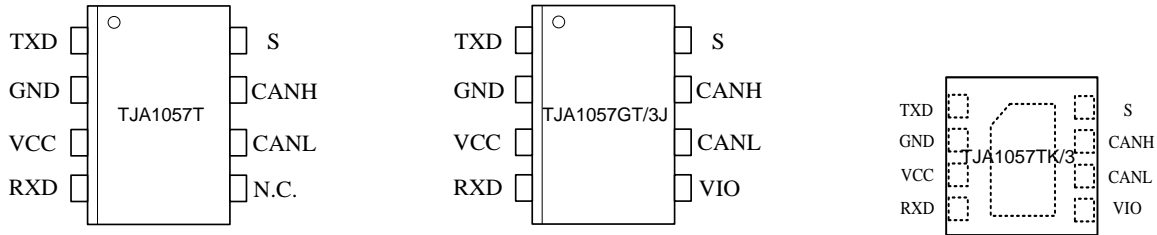
SOP-8

## DESCRIPTION

TJA1057 is an interface chip used between the CAN protocol controller and the physical bus. It can be used in trucks, buses, cars, industrial control and other fields. It supports 5Mbps (CAN FD) flexible data rate, and has the ability to perform differential signal transmission between bus and the CAN protocol controller.

PARAMETER	SYMBOL	CONDITION	MIN.	MAX.	UNIT
Supply voltage	VCC		4.75	5.25	V
VIO voltage	VIO		2.95	5.25	V
Maximum transmission rate	1/tbit	Non-return to zero code	5		Mbaud
CANH/CANL input or output voltage	V <sub>can</sub>		-40	+40	V
Bus differential voltage	V <sub>diff</sub>		1.5	3.0	V
Virtual junction temperature	T <sub>j</sub>		-40	150	°C

### PIN CONFIGURATION



### LIMITING VALUES

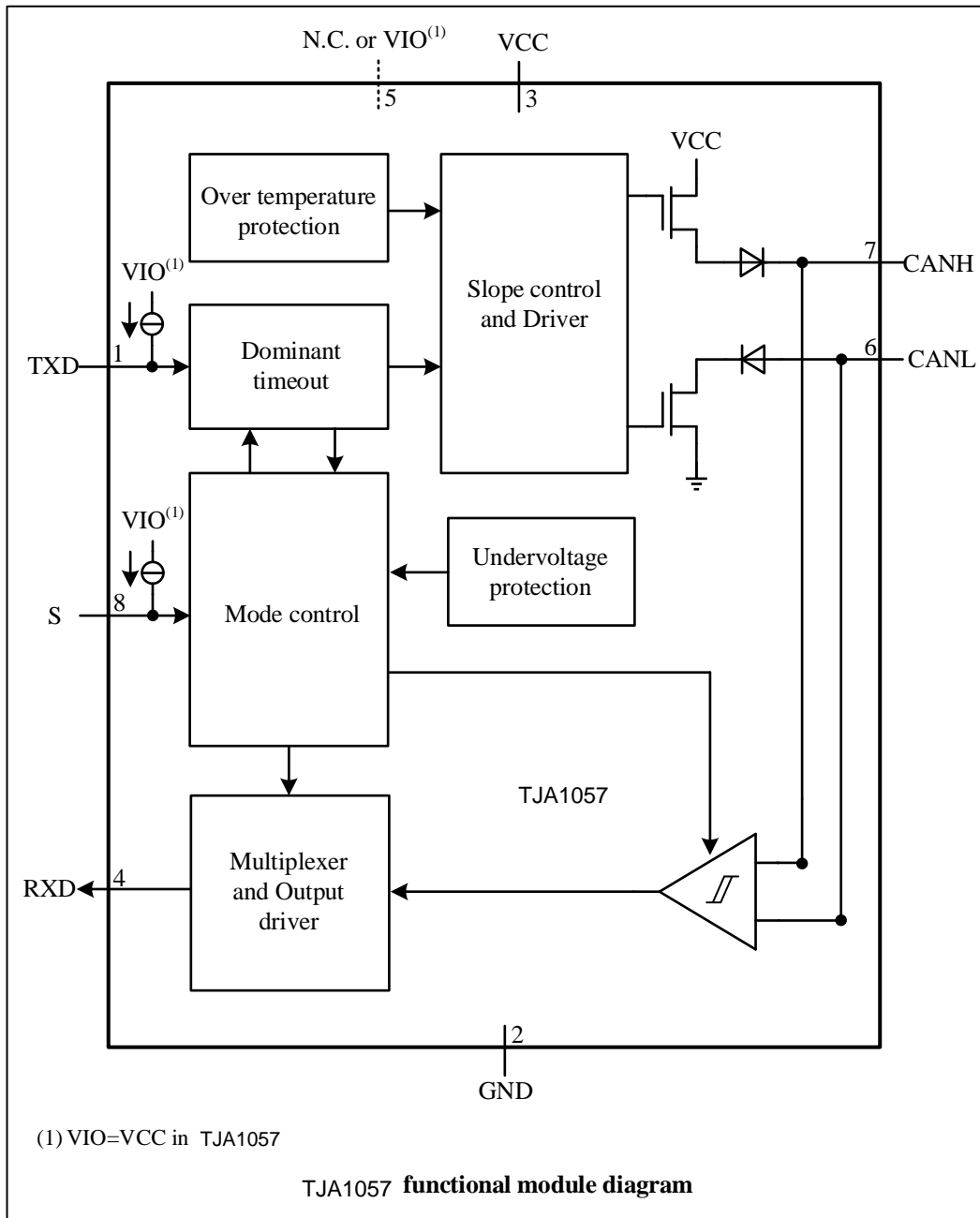
PARAMETER	SYMBOL	VALUE	UNIT
Supply voltage	VCC	-0.3~+7	V
MCU side port voltage	TXD, RXD, S, VIO	-0.3~+7	V
Bus side input voltage	CANL, CANH	-40~+40	V
Bus differential breakdown voltage	$V_{CANH-CANL}$	-27~27	V
Storage temperature	$T_{stg}$	-55~150	°C
Virtual junction temperature	$T_j$	-40~150	°C

The maximum limit parameters mean that exceeding these values may cause irreversible damage to the device. Under these conditions, it is not conducive to the normal operation of the device. The continuous operation of the device at the maximum allowable rating may affect the reliability of the device. The reference point for all voltages is ground.

### PINNING

PIN	SYMBOL	DESCRIPTION
1	TXD	transmit data input
2	GND	ground
3	VCC	supply voltage
4	RXD	receive data output; reads out data from the bus lines
5	N.C.	not connected ( TJA1057T )
5	VIO	transceiver I/O level conversion power supply voltage ( TJA1057GT3J )
6	CANL	LOW-level CAN bus line
7	CANH	HIGH-level CAN bus line
8	S	High speed mode control input, LOW-level is High speed mode

## FUNCTIONAL BLOCK DIAGRAM



## DRIVER ELECTRICAL CHARACTERISTICS

PARAMETER	SYMBOL	CONDITION	MIN.	TYP.	MAX.	UNIT
CANH dominant output voltage	$V_{OH(D)}$	TXD=0V, S=0V, $R_L=50\Omega$ to $65\Omega$ , Fig 1, Fig 2	2.75	3.5	4.5	V
CANL dominant output voltage	$V_{OL(D)}$		0.5	1.5	2.25	V
Bus dominant differential output voltage	$V_{OD(D)}$	TXD=0V, S=0V, $t < t_{dom\_TXD}$				
		$R_L=50\Omega$ to $65\Omega$	1.5		3	V
		$R_L=45\Omega$ to $70\Omega$	1.4		3.3	V
		$R_L=2240\Omega$	1.5		5	V
Bus recessive output voltage	$V_{O(R)}$	S=0V, TXD=VIO, no load	2	0.5VCC	3	V
Bus recessive differential output voltage	$V_{OD(R)}$	TXD=VIO, S=0V, no load	-0.5		0.05	V
Transmitter dominant voltage symmetry	$V_{dom(TX)sym}$	$V_{dom(TX)sym}=VCC-$ CANH - CANL	-400		400	mV
Transmitter voltage symmetry	$V_{TXsym}$	$V_{TXsym}=CANH+CANL$ <sup>(1)</sup> , $f_{TXD}=250kHz$ , 1MHz or 2.5MHz, $C_{SPLIT}=4.7nF$ , Fig 7	0.9VCC		1.1VCC	V
Common-mode output voltage	$V_{OC}$	S=0V	2	0.5VCC	3	V
Dominant short-circuit output current	$I_{OS\_dom}$	TXD=0V; $t < t_{dom\_TXD}$ ; VCC=5V				
		Pin CANH, CANH=-15V to 40V	-100		100	mA
		Pin CANL, CANL=-15V to 40V	-100		100	mA
Recessive short-circuit output current	$I_{OS\_rec}$	TXD=VIO, $-27V < CANH < 32V$	-5		5	mA

(1) Not tested in production; guaranteed by design.

Unless otherwise stated, all typical values are measured at 25°C, supply voltage VCC=5V, VIO=5V (if applicable),  $R_L=60\Omega$ .

## DRIVER SWITCHING CHARACTERISTICS

PARAMETER	SYMBOL	CONDITION	MIN.	TYP.	MAX.	UNIT
Driver timing; pins CANH, CANL, RXD; see Fig 3 and Fig 5 and Fig 6; $R_L=60\Omega$ ; $C_L=100pF$ ; $C_{RXD}=15pF$ .						
Propagation delay time, TXD to bus recessive	$t_d(TXD\_busrec)$	S=0V, Fig 3, Fig 6		90		ns
Propagation delay time, TXD to bus dominant	$t_d(TXD\_busdom)$	S=0V, Fig 3, Fig 6		65		ns

PARAMETER	SYMBOL	CONDITION	MIN.	TYP.	MAX.	UNIT
Differential output signal rise time	$t_r$	S=0V, Fig 3, Fig 6		45		ns
Differential output signal fall time	$t_f$	S=0V, Fig 3, Fig 6		45		ns
TXD dominant time-out time	$t_{dom\_TXD}$	Fig 4	0.8	3	6.5	ms

Unless otherwise stated, all typical values are measured at 25°C, supply voltage VCC=5V, VIO=5V (if applicable), RL=60Ω.

## RECEIVER ELECTRICAL CHARACTERISTICS

PARAMETER	SYMBOL	CONDITION	MIN.	TYP.	MAX.	UNIT
Positive-going input threshold voltage	$V_{IT+}$	Normal/Silence mode, $-12\text{ V} \leq V_{CANL} \leq +12\text{ V}$ , $-12\text{ V} \leq V_{CANH} \leq +12\text{ V}$			900	mV
Negative-going input threshold voltage	$V_{IT-}$	Normal/Silence mode, $-12\text{ V} \leq V_{CANL} \leq +12\text{ V}$ , $-12\text{ V} \leq V_{CANH} \leq +12\text{ V}$	500			mV
Hysteresis voltage ( $V_{TH+\_dif} - V_{TH-\_dif}$ )	$V_{HYS}$	Normal/Silence mode, $-12\text{ V} \leq V_{CANL} \leq +12\text{ V}$ , $-12\text{ V} \leq V_{CANH} \leq +12\text{ V}$		120		mV
Receiver dominant differential input voltage	$V_{dom\_Diff}$	Normal/Silence mode, $-12\text{ V} \leq V_{CANL} \leq +12\text{ V}$ , $-12\text{ V} \leq V_{CANH} \leq +12\text{ V}$	0.9		8.0	V
Receiver recessive differential input voltage	$V_{rec\_Diff}$	Normal/Silence mode, $-12\text{ V} \leq V_{CANL} \leq +12\text{ V}$ , $-12\text{ V} \leq V_{CANH} \leq +12\text{ V}$	-3		0.5	V
Power-off bus input current	$I_{(OFF)}$	$V_{CANH} = V_{CANL} = 5\text{V}$ , $GND = VCC = VIO = 0\text{V}$	-5		5	μA
Input capacitance to ground, (CANH or CANL)	$C_I$	(1)			24	pF
Differential input capacitance	$C_{ID}$	(1)			12	pF
Slew Rate	SR	Bus differential voltage dominant to recessive edge (1)			70	V/μs
Input resistance, (CANH or CANL)	$R_{IN}$	$V_{TXD} = V_{IO}$ , $V_S = 0\text{V}$ , (1) $-2\text{ V} \leq V_{CANL} \leq +7\text{ V}$ , $-2\text{ V} \leq V_{CANH} \leq +7\text{ V}$	9	15	28	kΩ
Differential input resistance	$R_{ID}$		19	30	52	kΩ
CANH, CANL input resistance mismatch	$R_{I\_match}$	$CANH = CANL$ , (1) $0\text{ V} \leq V_{CANL} \leq +5\text{ V}$ , $0\text{ V} \leq V_{CANH} \leq +5\text{ V}$	-2		2	%
The range of common-mode voltage	$V_{COM}$		-12		12	V

(1) Not tested in production; guaranteed by design.

Unless otherwise stated, all typical values are measured at 25°C, supply voltage VCC=5V, VIO=5V (if applicable), RL=60Ω.

## RECEIVER SWITCHING CHARACTERISTICS

PARAMETER	SYMBOL	CONDITION	MIN.	TYP.	MAX.	UNIT
Receive timing; pins CANH, CANL, RXD; see Fig 3 and Fig 5 and Fig 6; $R_L=60\Omega$ ; $C_L=100\text{pF}$ ; $C_{RXD}=15\text{pF}$ .						
Propagation delay time, bus recessive to RXD	$t_{d(\text{busrec\_RXD})}$	S=0V, Fig 3, Fig 6		65		ns
Propagation delay time, bus dominant to RXD	$t_{d(\text{busdom\_RXD})}$	S=0V, Fig 3, Fig 6		60		ns
RXD signal rise time	$t_r$	S=0V, Fig 3, Fig 6		10		ns
RXD signal fall time	$t_f$	S=0V, Fig 3, Fig 6		10		ns

Unless otherwise stated, all typical values are measured at 25°C, supply voltage VCC=5V, VIO=5V (if applicable),  $R_L=60\Omega$ .

## DEVICE SWITCHING CHARACTERISTIC

PARAMETER	SYMBOL	CONDITION	MIN.	TYP.	MAX.	UNIT
Receive timing; pins CANH, CANL, TXD and RXD; see Fig.3 and Fig.5 and Fig.6; $R_L=60\Omega$ ; $C_L=100\text{pF}$ ; $C_{RXD}=15\text{pF}$ .						
Loop delay 1, driver input to receiver output, Recessive to Dominant	$t_{\text{loop1}}$	S=0V, Fig 3, Fig 6		80	220	ns
Loop delay 2, driver input to receiver output, Dominant to Recessive	$t_{\text{loop2}}$	S=0V, Fig 3, Fig 6		90	220	ns
Bit time of BUS output pin	$t_{\text{bit}(\text{BUS})}$	$t_{\text{bit}(\text{TXD})}=500\text{ns}$ Fig 5, Fig 6	435		530	ns
		$t_{\text{bit}(\text{TXD})}=200\text{ns}$ Fig 5, Fig 6	155		210	ns
Bit time of RXD output pin	$t_{\text{bit}(\text{RXD})}$	$t_{\text{bit}(\text{TXD})}=500\text{ns}$ Fig 5, Fig 6	400		550	ns
		$t_{\text{bit}(\text{TXD})}=200\text{ns}$ Fig 5, Fig 6	120		220	ns
Receiver timing symmetry	$\Delta t_{\text{rec}}$	$t_{\text{bit}(\text{TXD})}=500\text{ns}$ Fig 5, Fig 6	-65		+40	ns
		$t_{\text{bit}(\text{TXD})}=200\text{ns}$ Fig 5, Fig 6	-45		+15	ns

Unless otherwise stated, all typical values are measured at 25°C, supply voltage VCC=5V, VIO=5V (if applicable),  $R_L=60\Omega$ .

## OVER TEMPERATURE PROTECTION

PARAMETER	SYMBOL	CONDITION	MIN.	TYP.	MAX.	UNIT
Shutdown junction temperature	$T_{j(sd)}$			190		°C

Unless otherwise stated, all typical values are measured at 25°C, supply voltage VCC=5V, VIO=5V (if applicable), RL=60Ω.

## UNDERVOLTAGE PROTECTION

PARAMETER	SYMBOL	CONDITION	MIN.	TYP.	MAX.	UNIT
VCC undervoltage protection	$V_{uvd\_VCC}$		3.5	3.9	4.3	V
VIO under-voltage protection	$V_{uvd\_VIO}$		2.1	2.5	2.7	V

Unless otherwise stated, all typical values are measured at 25°C, supply voltage VCC=5V, VIO=5V (if applicable), RL=60Ω.

## TXD PIN CHARACTERISTICS

PARAMETER	SYMBOL	CONDITION	MIN.	TYP.	MAX.	UNIT
HIGH-level input current	$I_{IH}(TXD)$	TXD=VIO	-5		5	μA
LOW-level input current	$I_{IL}(TXD)$	TXD=0V	-260	-150	-30	μA
When VCC=0V, current on TXD pin	$I_{O(off)}$	VCC=VIO=0V, TXD=VIO	-1		1	μA
HIGH-level input voltage	$V_{IH}$		$0.7V_{IO}^{(1)}$		$V_{IO}^{(1)}+0.3$	V
LOW-level input voltage	$V_{IL}$		-0.3		$0.3V_{IO}^{(1)}$	V
Open voltage on TXD pin	TXD <sub>O</sub>		H			logic

(1)  $V_{IO}=V_{CC}$  in TJA1057T

Unless otherwise stated, all typical values are measured at 25°C, supply voltage VCC=5V, VIO=5V (if applicable), RL=60Ω.

## S PIN CHARACTERISTICS

PARAMETER	SYMBOL	CONDITION	MIN.	TYP.	MAX.	UNIT
HIGH-level input current	$I_{IH}(S)$	S=VIO	-1		1	μA
LOW-level input current	$I_{IL}(S)$	S=0V	-15		-1	μA
When VCC=0V, current	$I_{O(off)}$	VCC=VIO=0V,	-1		1	μA

PARAMETER	SYMBOL	CONDITION	MIN.	TYP.	MAX.	UNIT
on S pin		S=VIO				
HIGH-level input voltage	V <sub>IH</sub>		0.7V <sub>IO</sub> <sup>(1)</sup>		V <sub>IO</sub> <sup>(1)</sup> +0.3	V
LOW-level input voltage	V <sub>IL</sub>		-0.3		0.3V <sub>IO</sub> <sup>(1)</sup>	V
Open voltage on S pin	S <sub>O</sub>		H			Logic

(1) V<sub>IO</sub>=V<sub>CC</sub> in TJA1057T

Unless otherwise stated, all typical values are measured at 25°C, supply voltage V<sub>CC</sub>=5V, V<sub>IO</sub>=5V (if applicable), R<sub>L</sub>=60Ω.

## RXD PIN CHARACTERISTICS

PARAMETER	SYMBOL	CONDITION	MIN.	TYP.	MAX.	UNIT
HIGH-level input current	I <sub>OH</sub> (RXD)	V <sub>IO</sub> =V <sub>CC</sub> , RXD=V <sub>IO</sub> -0.4V	-8	-3	-1	mA
LOW-level input current	I <sub>OL</sub> (RXD)	RXD=0.4V	1		12	mA
When V <sub>CC</sub> =0V, current on RXD pin	I <sub>O</sub> (off)	V <sub>CC</sub> =V <sub>IO</sub> =0V, RXD=V <sub>IO</sub>	-1		1	μA

Unless otherwise stated, all typical values are measured at 25°C, supply voltage V<sub>CC</sub>=5V, V<sub>IO</sub>=5V (if applicable), R<sub>L</sub>=60Ω.

## SUPPLY CURRENT

PARAMETER	SYMBOL	CONDITION	MIN.	TYP.	MAX.	UNIT
VCC current (Silence mode)	I <sub>CC</sub>	S=V <sub>CC</sub> , TXD=V <sub>IO</sub> , TJA1057T and TJA1057GT3J	0.1		1.2	mA
VCC current (Dominant)		TXD=V <sub>IO</sub> , S=0V, load=60Ω		45	70	mA
VCC current (Recessive)		TXD=V <sub>IO</sub> , S=0V, no load		5	10	mA
VIO current (Silence mode)	I <sub>IO</sub>	S=TXD=V <sub>IO</sub>		3	16	μA
VIO current (Dominant)		TXD=0V, S=0V		110	320	μA
VIO current (Recessive)		TXD=V <sub>IO</sub> , S=0V		7	30	μA

Unless otherwise stated, all typical values are measured at 25°C, supply voltage V<sub>CC</sub>=5V, V<sub>IO</sub>=5V (if applicable), R<sub>L</sub>=60Ω.



## ESD PERFORMANCE

PARAMETER	SYMBOL	CONDITION	MIN.	TYP.	MAX.	UNIT
CAN bus pin contact discharge model (IEC)	$V_{ESD\_IEC}$	IEC 61000-4-2: Contact discharge	-4		+4	kV
CAN bus pin human body discharge model (HBM)	$V_{ESD\_HBM}$		-8		+8	kV

## FUNCTION TABLE

**Table1. CAN TRANSCEIVER TRUTH TABLE**

TXD <sup>(1)</sup>	S <sup>(1)</sup>	CANH <sup>(1)</sup>	CANL <sup>(1)</sup>	BUS STATE	RXD <sup>(1)</sup>
L	L	H	L	Dominate	L
H or Open	L	0.5VCC	0.5VCC	Recessive	H
X	H or Open	0.5VCC	0.5VCC	Recessive	H
X	H or Open	H	L	Dominate	L

(1) H=high level; L=low level; X=irrelevant.

**Table 2. RECEIVER FUNCTION TABLE**

$V_{ID}=CANH-CANL$	RXD <sup>(1)</sup>	BUS STATE
$V_{ID} \geq 0.9V$	L	Dominate
$0.5 < V_{ID} < 0.9V$	?	?
$V_{ID} \leq 0.5V$	H	Recessive
Open	H	Recessive

(1) H=high-level; L=low-level; ?=uncertain.

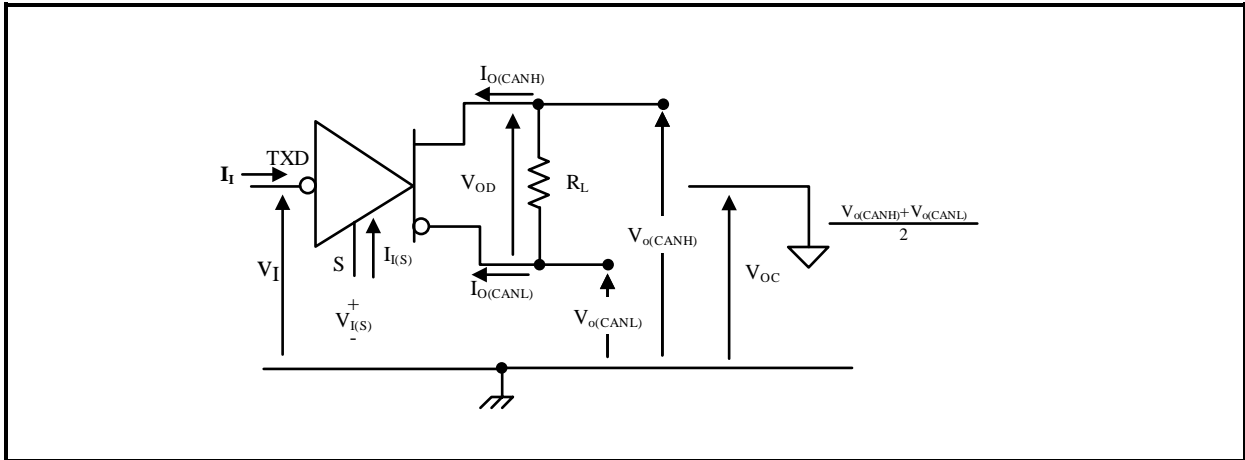
**Table 3. Under-voltage protection status table**

VCC	VIO <sup>(1)</sup>	BUS STATE	BUS OUTPUT <sup>(2)</sup>	RXD <sup>(2)</sup>
$VCC > V_{uvd\_VCC}$	$VIO > V_{uvd\_VIO}$	normal	According to S and TXD	Follow the bus
$VCC < V_{uvd\_VCC}$	$VIO > V_{uvd\_VIO}$	Protected state	Z	H
$VCC > V_{uvd\_VCC}$	$VIO < V_{uvd\_VIO}$	Protected state	Z	H
$VCC < V_{uvd\_VCC}$	$VIO < V_{uvd\_VIO}$	Protected state	Z	H

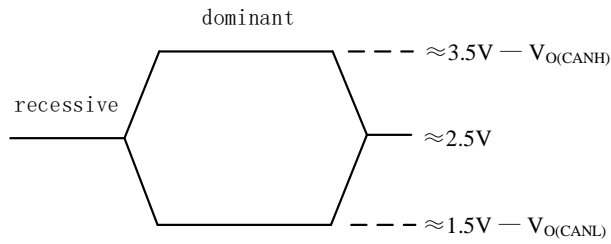
(1) Only TJA1057GT/3J version;

(2) H=high level; Z=high ohmic.

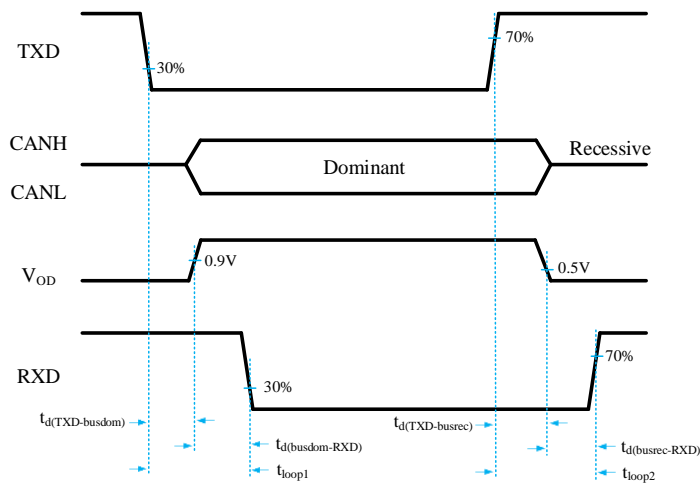
**TEST CIRCUIT**



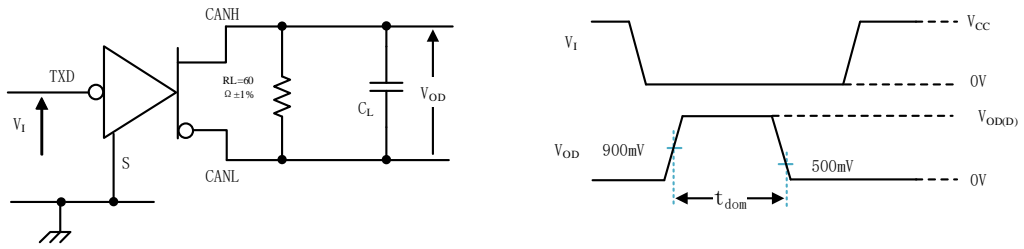
**Fig 1 Test Definition of Driver Voltage and Current**



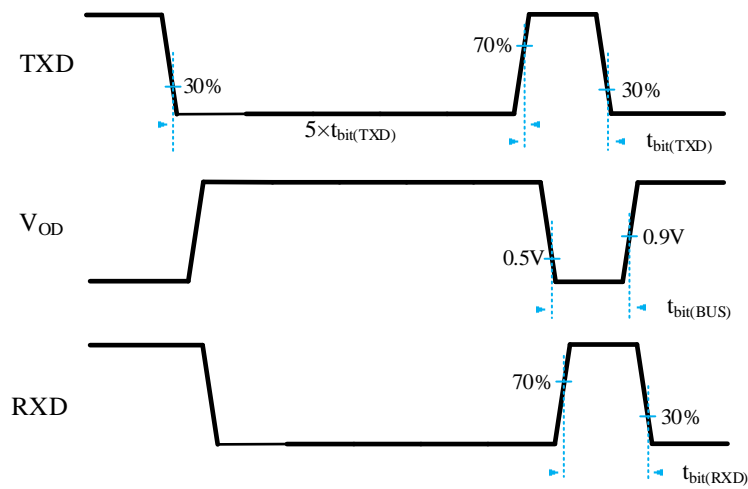
**Fig 2 Bus Logic State Voltage Definition**



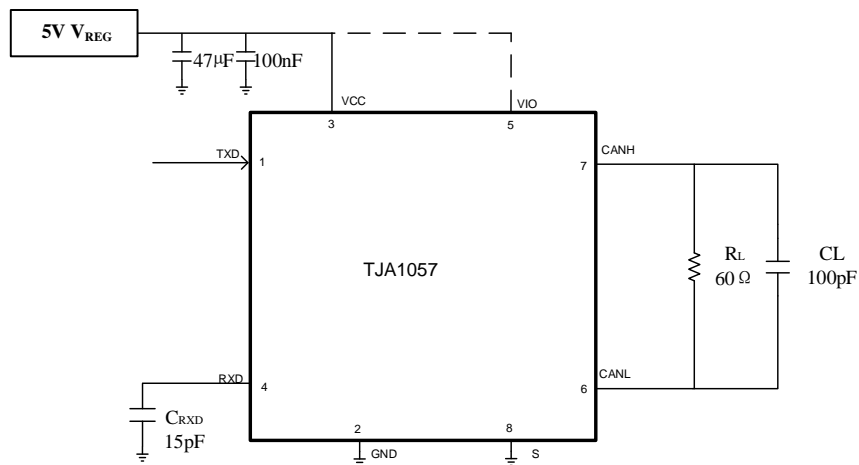
**Fig 3 Transceiver timing diagram**



**Fig 4 Dominant timeout test circuit and waveform**

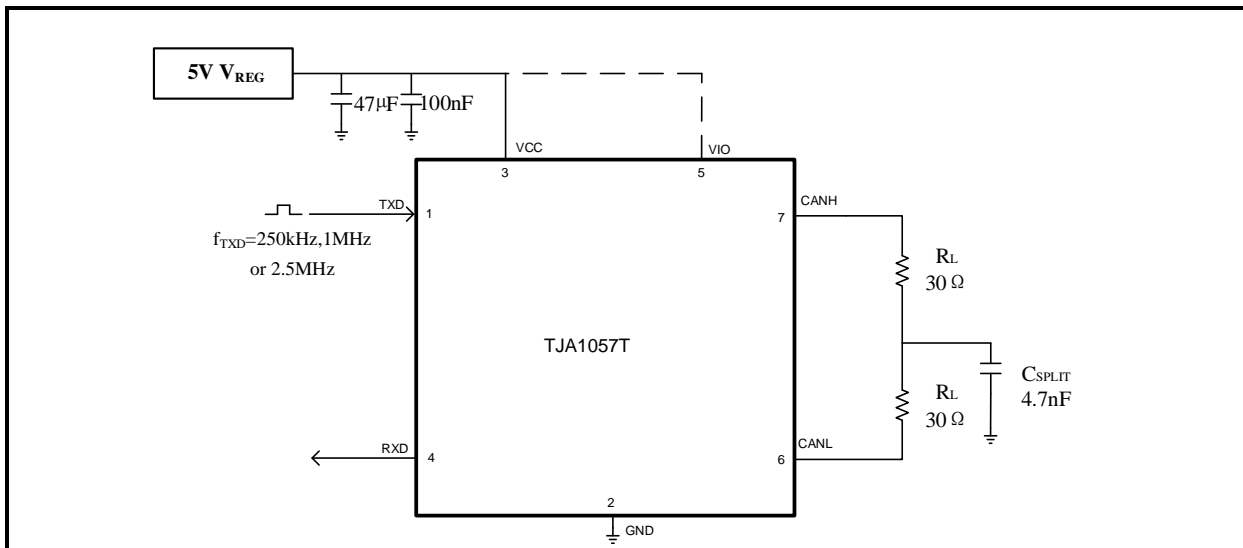


**Fig 5  $t_{bit}$  test circuit and waveform**



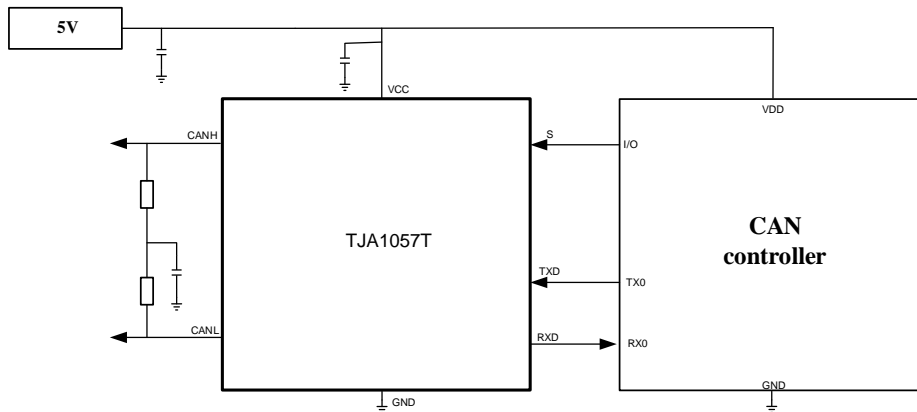
The VIO pin is internally connected to pin VCC in the non-VIO product variants TJA1057T

**Fig 6 CAN transceiver timing test circuit**

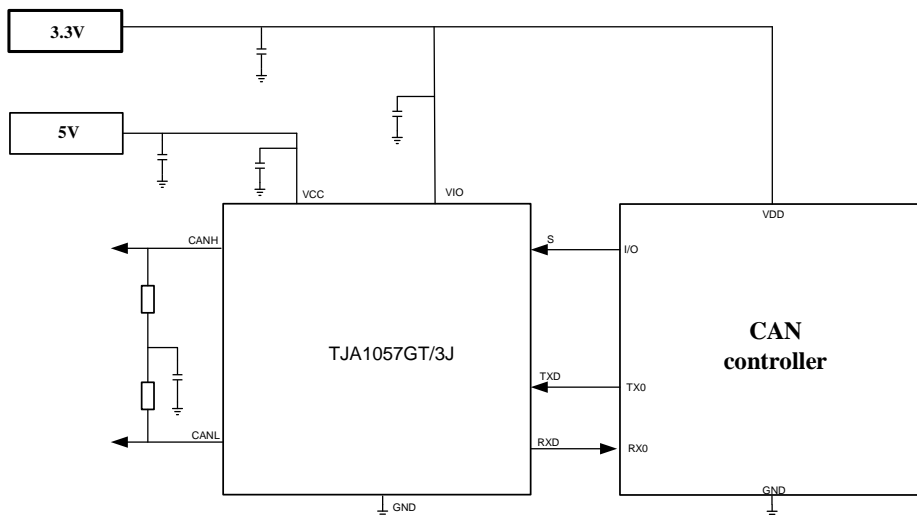


**Fig 7 Test circuit for measuring transmitter driver symmetry**

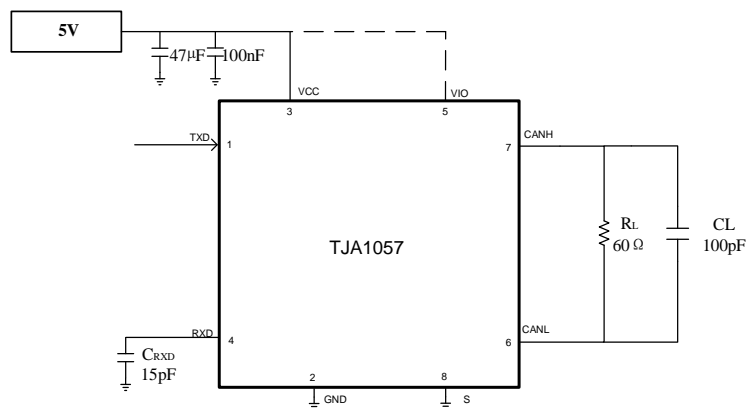
## TYPICAL APPLICATION TEST



TJA1057T typical application diagram



TJA1057GT/3J typical application diagram



(1) VIO is limited to TJA1057GT3J, VIO=VCC in TJA1057T

TJA1057 typical high-speed mode test chart

## ADDITIONAL DESCRIPTION

### 1 Sketch

The TJA1057 is an interface chip applied between the CAN protocol controller and the physical bus. It can be used in trucks, buses, cars, industrial control and other fields. It supports 5Mbps (CAN FD) flexible data rate, and has the ability to perform differential signal transmission between bus and the CAN protocol controller. In addition, the TJA1057 is fully compatible with "ISO 11898-2: 2016" standard.

### 2 Over temperature protection

The TJA1057 has an over-temperature protection function. After the over-temperature protection is triggered, the drive tube will be turned off, because the drive tube is the main energy-consuming component. Turning off the drive tube can reduce power consumption and thus reduce the chip temperature. At the same time, other parts of the chip are still working normally.

### 3 Undervoltage protection

The TJA1057 power supply pin has an under-voltage detection function, which can put the device in a protected mode. This protects the bus when VCC is lower than  $V_{\text{uvd\_VCC}}$  or VIO is lower than  $V_{\text{uvd\_VIO}}$  (if applicable).

### 4 Operating modes

The control pin S allows two working modes to be selected: high-speed mode and silence mode.

The high-speed mode is a normal operating mode and is selected by grounding the pin S. Both the CAN driver and the receiver can operate normally and CAN communication is carried out in both directions.

In silence mode, the transmitter is disabled and the receiver working normally. The silence mode can be selected by connecting the pin S to VCC, can be used to prevent blocking of network signals due to uncontrolled CAN controller.

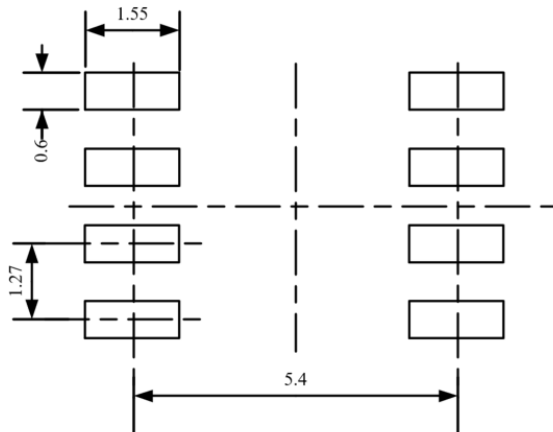
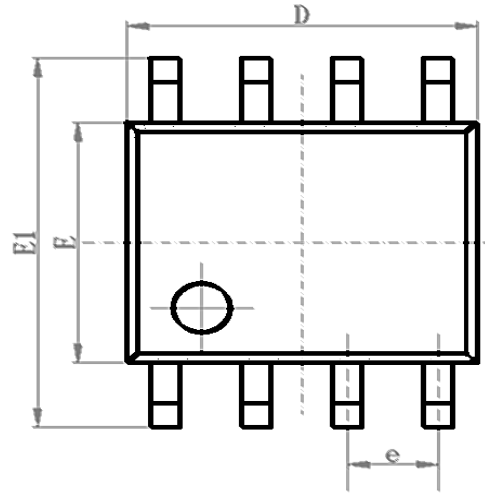
### 5 TXD dominant time-out function

In high-speed mode, if the low-level duration on pin TXD exceeds the internal timer value ( $t_{\text{dom\_BUS}}$ ), the transmitter will be disabled and will drive the bus into a recessive state. It can prevent the pin TXD from being forced to a permanent low level due to a hardware or software application failure, causing the bus line to be driven to a permanent dominant state (blocking all network communications). A rising edge signal on pin TXD can be reset.

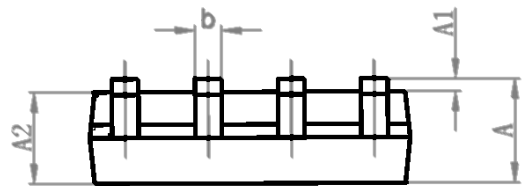
### SOP8 DIMENSIONS

#### PACKAGE SIZE

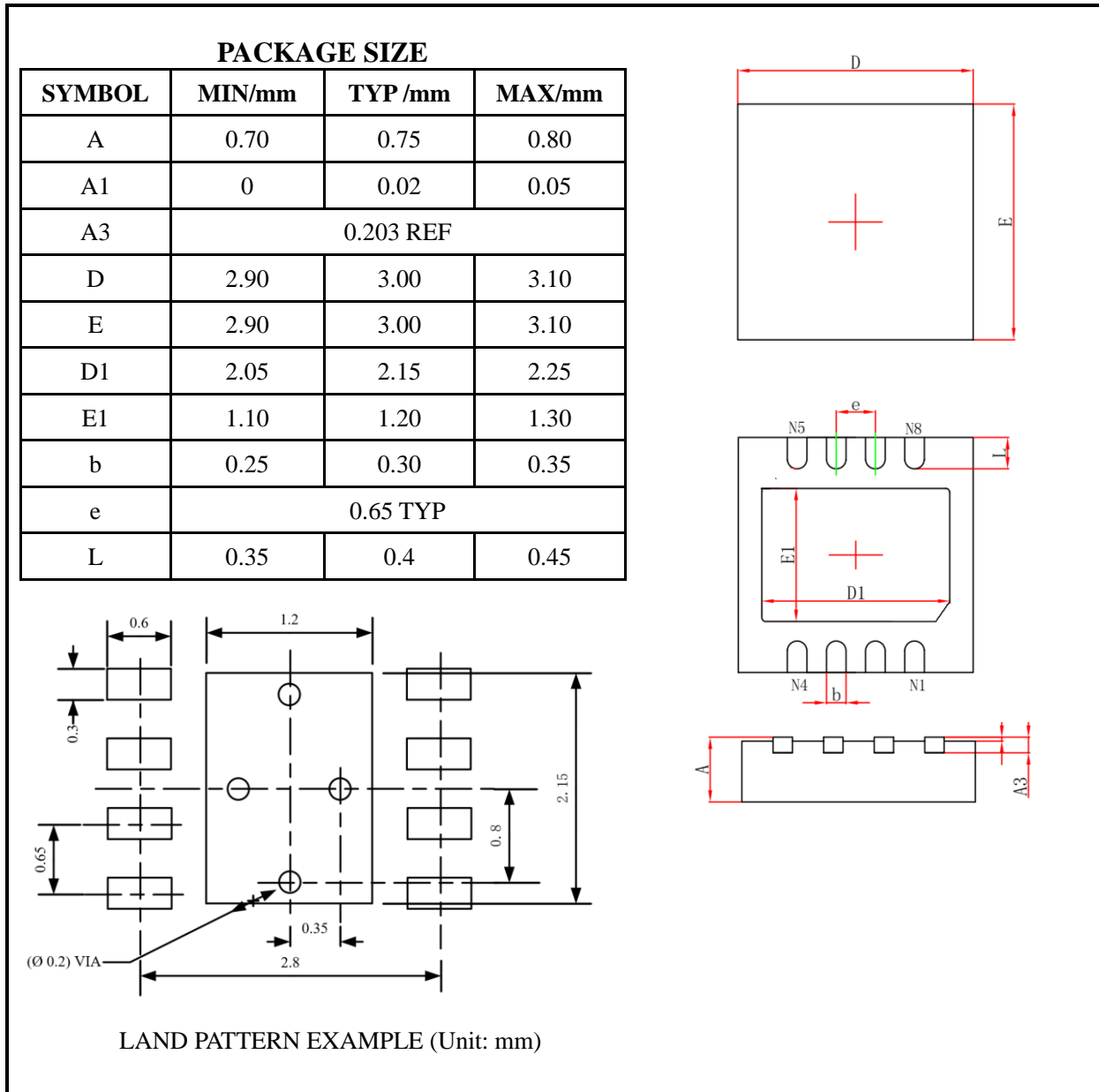
SYMBOL	MIN/mm	TYP /mm	MAX/mm
A	1.40	-	1.80
A1	0.10	-	0.25
A2	1.30	1.40	1.50
b	0.38	-	0.51
D	4.80	4.90	5.00
E	3.80	3.90	4.00
E1	5.80	6.00	6.20
e	1.27BSC		
L	0.40	0.60	0.80
c	0.20	-	0.25
$\theta$	0°	-	8°



LAND PATTERN EXAMPLE (Unit: mm)



### DFN3\*3-8 DIMENSIONS



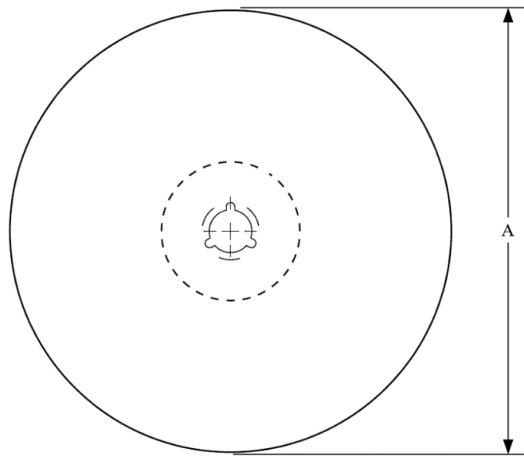
### ORDERING INFORMATION

TYPE NUMBER	PACKAGE	PACKING
TJA1057T	SOP8	Tape and reel
TJA1057GT/3J	SOP8	Tape and reel
TJA1057TK/3	DFN3*3-8, small shape, no leads, 8 terminals	Tape and reel

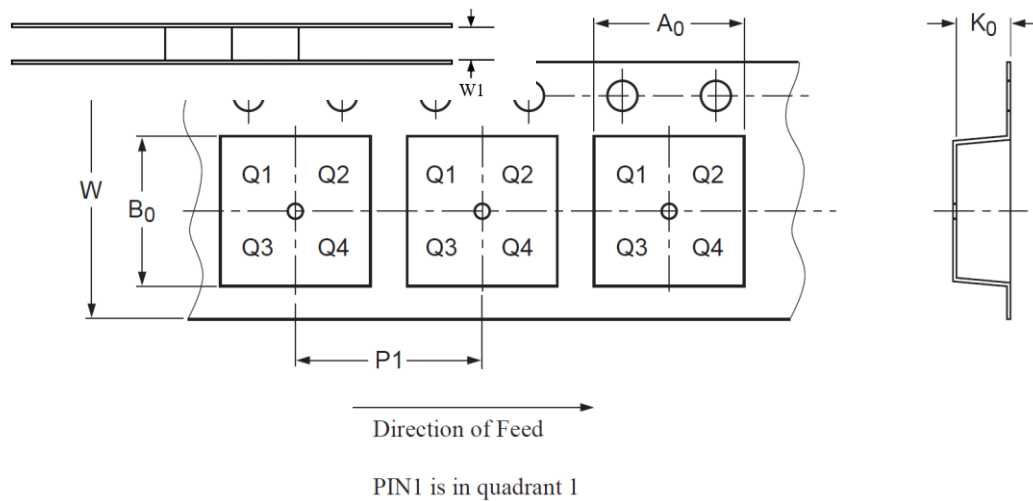
SOP8 is packed with 2500 pieces/disc in braided packaging. Leadless DFN3\*3-8 is packed with 6000 pieces/disc in braided packaging.



### TAPE AND REEL INFORMATION

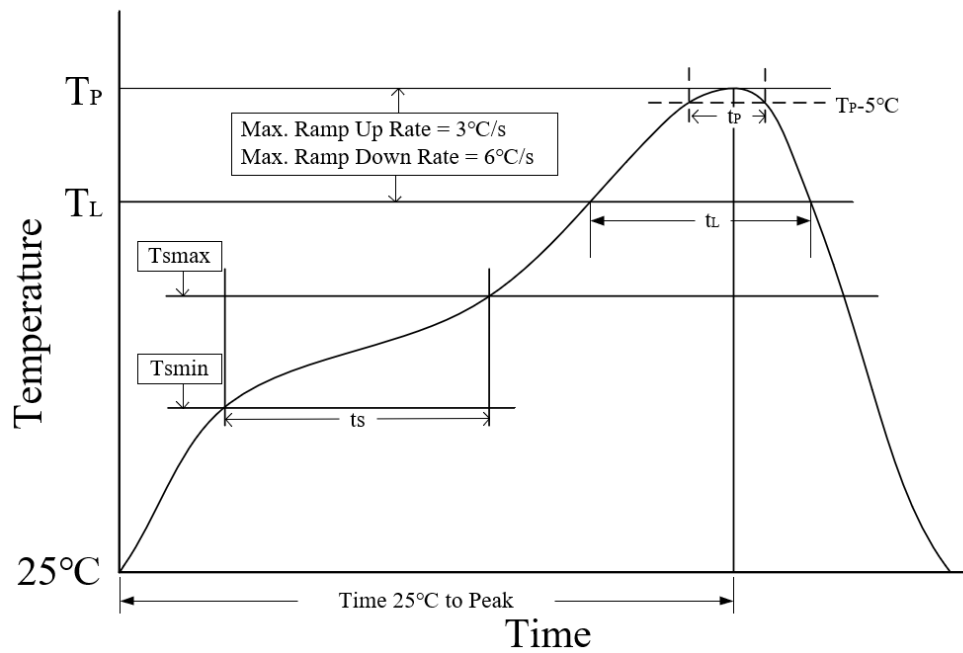


A0	Dimension designed to accommodate the component width
B0	Dimension designed to accommodate the component length
K0	Dimension designed to accommodate the component thickness
W	Overall width of the carrier tape
P1	Pitch between successive cavity centers



Package Type	Reel Diameter A (mm)	Tape Width W1 (mm)	A0 (mm)	B0 (mm)	K0 (mm)	P1 (mm)	W (mm)
SOP8	330±1	12.4	6.60±0.1	5.30±0.10	1.90±0.1	8.00±0.1	12.00±0.1
DFN3*3-8	329±1	12.4	3.30±0.1	3.30±0.1	1.10±0.1	8.00±0.1	12.00±0.3

## REFLOW SOLDERING



Parameter	Lead-free soldering conditions
Ave ramp up rate ( $T_L$ to $T_P$ )	3 °C/second max
Preheat time $t_s$ ( $T_{smin}=150\text{ °C}$ to $T_{smax}=200\text{ °C}$ )	60-120 seconds
Melting time $t_L$ ( $T_L=217\text{ °C}$ )	60-150 seconds
Peak temp $T_P$	260-265 °C
5°C below peak temperature $t_P$	30 seconds
Ave cooling rate ( $T_P$ to $T_L$ )	6 °C/second max
Normal temperature 25°C to peak temperature $T_P$ time	8 minutes max

## X-ON Electronics

Largest Supplier of Electrical and Electronic Components

*Click to view similar products for [CAN Interface IC category](#):*

*Click to view products by [Tokmas manufacturer](#):*

Other Similar products are found below :

[PCA82C250T/N4](#) [TLE7251VLE](#) [SIT1051AT/3](#) [TJA1042T](#) [TJA1044T](#) [TJA1040T](#) [TJA1051T/3](#) [TPT1042V-SO1R-S](#) [SCM3425ASA](#)  
[NCA1042-DSPR](#) [SIT1057QTK/3](#) [SIT1042AQT/3](#) [SIT1051AQT/3](#) [SIT1044QTK/3](#) [MCP2515-I](#) [TJA1051T](#) [PCA82C251T](#) [MAX3051ESA](#)  
[UM3608QA](#) [CA-IF1042VS-Q1](#) [CA-IF1044VS-Q1](#) [HMT1050T](#) [HMT1040T](#) [HGA82C251M/TR](#) [TJA1040M/TR](#) [HG65HVD230M/TR](#)  
[TJA1042M-3/TR](#) [PCA82C251M/TR](#) [TDA51SCANHC](#) [TJA1044GT/1](#) [TJA1055T/3/1](#) [SIT1042AQT/3](#) [SIT1051AT](#) [SIT1044QT/3](#)  
[SIT1057QT](#) [SIT1042QT](#) [SIT1051QT](#) [SIT1057QT/3](#) [SIT1051AQT/E](#) [SIT1057T/3](#) [SIT1043QTK](#) [SIT1042AT](#) [SIT1042AQT](#) [SIT1042AT/3](#)  
[SIT1043QT](#) [SIT1042ATK/3](#) [SIT1057TK/3](#) [SL1040S](#) [SJA1000M/TR](#) [HT82C251ANZ](#)