

规格書

SPECIFICATION

Customer : 深圳市立創電子商務有限公司

Part Name: E-CAP

SPEC : LJ Series

Part NO. : ALL

Date : 2021-7-26

CUSTOMER SIGN		

TOPAZCON	
DRAWING	RATIFY
李梦如	<i>Cocp</i>

LJ Series

- High performance, high reliability.
- Low impedance, high ripple current, long life.
- Endurance: +105°C 4000-10000 hours.
- RoHS Compliant

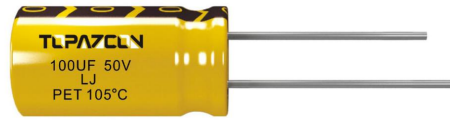

SPECIFICATIONS

Item	Performance Characteristics											
Temperature Range	-40 to +105°C											
Working Voltage Range	6.3 to 120Vdc											
Capacitance Range	6.8 to 18000 μ F											
Capacitance Tolerance	$\pm 20\%$ (at 20°C and 120Hz)											
Dissipation Factor (tan δ)	Rated Voltage (V)	6.3	10	16	25	35	50	63	80	100	120	(at 20°C, 120Hz)
	Tan δ (Max)	0.22	0.19	0.16	0.14	0.12	0.10	0.09	0.08	0.08	0.12	
Low Temperature Characteristics (Max. Impedance Ratio)	Rate voltage (V)	6.3	10	16	25	35	50	63	80	100	120	(at 120Hz)
	Z(-25°C)/Z(+20°C)	4	3	2						3		
	Z(-40°C)/Z(+20°C)	8	6	4	3						6	
Leakage Current	$I \leq 0.01CV$ or $3\mu A$ Whichever is greater (at 20°C after 2 minutes) Where, I: Max. Leakage current (μA); C: Nominal capacitance (μF); V: Rated voltage (V).											
Endurance	The following specification shall be satisfied when the capacitor are restored to 20°C after subjected to DC voltage with the rated ripple current is applied for the specified period of time at 105°C.											
	Capacitance change	$\leq \pm 20\%$ of the initial value (6.3-10V $\leq \pm 30\%$)										
	Dissipation	$\leq 200\%$ of the specified value										
Shelf Life	The following requirements shall be satisfied when the capacitor are restored to 20°C after exposing them for 1000 hours at 105°C without voltage applied.											
	Capacitance change	$\leq \pm 20\%$ of the initial value (6.3-10V $\leq \pm 30\%$)										
	Dissipation	$\leq 200\%$ of the specified value										

DIMENSIONS (mm)

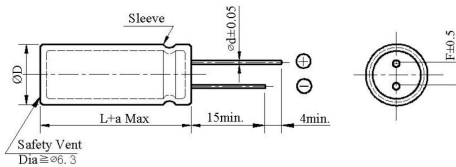

ΦD	5	6.3	8	10	12.5	16	18
Φd	0.5	0.5	0.5	0.6	0.6	0.8	0.8
F	2.0	2.5	3.5	3.5	5.0	7.5	7.5
a	+2max						

RIPPLE CURRENT MULTIPLIERS

Frequency correction factor for ripple current (Hz)

μF \ Hz	120	1K	10K	100K
Cap < 220	0.40	0.75	0.90	1.00
220 \leq Cap < 680	0.50	0.85	0.94	1.00
680 \leq Cap < 2200	0.60	0.87	0.95	1.00
2200 \leq Cap < 4700	0.75	0.90	0.95	1.00

LJ Series

◆ STANDARD RATINGS

(Impedance at 20°C 100KHz/Qmax. Ripple current ;mAms/105°C 100KHz)

WV (Vdc)	Cap (uF)	CaSe size Ø D×L (mm)	Tan δ	Impedance (Ωmax)	Ripple current (mAms)	WV (Vdc)	Cap (uF)	CaSe size Ø D×L (mm)	Tan δ	Impedance (Ωmax)	Ripple current (mAms)
6.3 (0J)	150	5×11	0.22	0.57	200	16 (1C)	56	5×11	0.16	0.57	200
		6.3×9	0.22	0.74	180			6.3×9	0.16	0.74	180
	330	6.3×11	0.22	0.21	350		120	6.3×11	0.16	0.21	350
		8×9	0.22	0.27	310			8×9	0.16	0.27	310
	680	8×12	0.22	0.13	660		330	8×12	0.16	0.13	660
		10×9	0.22	0.17	590			10×9	0.16	0.17	590
	820	10×13	0.22	0.08	870		470	8×16	0.16	0.087	850
	1000	8×16	0.22	0.086	850			10×13	0.16	0.08	870
	1200	8×20	0.22	0.07	1050		680	8×20	0.16	0.069	1050
		10×16	0.22	0.06	1230			10×16	0.16	0.06	1230
	1500	10×20	0.22	0.046	1400		1000	10×20	0.16	0.046	1400
	1800	12.5×16	0.22	0.049	1450			12.5×16	0.16	0.049	1450
	2200	10×20	0.24	0.042	1650		1200	10×25	0.16	0.042	1650
		10×30	0.24	0.03	1920			10×30	0.16	0.031	1920
	2700	16×15	0.24	0.041	1950		1500	12.5×20	0.16	0.035	1910
		3300	12.5×20	0.26	0.035			1910	16×15	0.16	0.041
	3900	12.5×25	0.26	0.026	2230		2200	12.5×25	0.18	0.027	2230
	4700	12.5×30	0.28	0.024	2650			12.5×30	0.18	0.024	2650
	5600	12.5×35	0.30	0.02	2880		2700	16×20	0.18	0.027	2530
		16×20	0.30	0.027	2530			12.5×35	0.20	0.02	2880
		12.5×40	0.32	0.017	3350			12.5×40	0.20	0.017	3350
	6800	16×25	0.32	0.02	2930		3900	16×25	0.20	0.021	2930
		18×20	0.32	0.026	2860			18×20	0.20	0.026	2860
		8200	16×30	0.36	0.017			3450	16×30	0.22	0.017
10000	16×35	0.40	0.015	3610	4700	18×25	0.22	0.019	3140		
	18×25	0.40	0.019	3140		16×35	0.24	0.015	3610		
12000	16×40	0.44	0.013	4100	5600	18×30	0.24	0.015	4170		
	18×30	0.44	0.015	4170		6800	16×40	0.26	0.013	4100	
15000	18×35	0.50	0.014	4220	8200	18×35	0.30	0.014	4220		
18000	18×40	0.56	0.012	4300	10000	18×40	0.34	0.012	4300		
10 (1A)	100	5×11	0.19	0.57	200	25 (1E)	47	5×11	0.14	0.57	200
		6.3×9	0.19	0.74	180			6.3×9	0.14	0.74	180
	220	6.3×11	0.19	0.21	350		100	6.3×11	0.14	0.21	350
		8×9	0.19	0.27	310			8×9	0.14	0.27	310
	470	8×12	0.19	0.13	660		220	8×12	0.14	0.13	660
		10×9	0.19	0.17	590			10×9	0.14	0.17	590
	680	8×16	0.19	0.086	850		330	8×16	0.14	0.086	850
		10×13	0.19	0.08	870			10×13	0.14	0.08	870
	1000	8×20	0.19	0.069	1050		470	8×20	0.14	0.069	1050
		10×16	0.19	0.06	1230			10×16	0.14	0.06	1230
	1200	10×20	0.19	0.046	1400		680	10×20	0.14	0.046	1400
	1500	10×25	0.19	0.042	1650			12.5×16	0.14	0.049	1450
		12.5×16	0.19	0.049	1450		10×25	0.14	0.042	1650	
	2200	10×30	0.21	0.03	1920		1000	10×30	0.14	0.03	1920
		12.5×20	0.21	0.035	1910			12.5×20	0.14	0.035	1910
		16×15	0.21	0.041	1950			16×15	0.14	0.041	1950
	3300	12.5×25	0.23	0.026	2230		1500	12.5×25	0.14	0.026	2230
	3900	12.5×30	0.23	0.024	2650			12.5×30	0.14	0.024	2650
		16×20	0.23	0.027	2530		1800	16×20	0.14	0.027	2530
	4700	12.5×35	0.25	0.02	2880			12.5×35	0.16	0.02	2880
		12.5×40	0.27	0.017	3350		2200	18×20	0.16	0.026	2860
	5600	16×25	0.27	0.021	2930			12.5×40	0.16	0.017	3350
		18×20	0.27	0.026	2860		2700	16×25	0.16	0.021	2930
		16×30	0.29	0.017	3450			16×30	0.18	0.017	3450
	6800	18×25	0.29	0.019	3140		3300	18×25	0.18	0.019	3140
		16×35	0.33	0.015	3610			16×35	0.18	0.015	3610
	8200	18×30	0.33	0.015	4170		3900	18×30	0.18	0.015	4170
		16×40	0.37	0.013	4100			16×40	0.20	0.013	4100
	10000	18×35	0.37	0.014	4220		4700	18×35	0.20	0.014	4220
		18×40	0.41	0.012	4300			18×40	0.22	0.012	4300

LJ Series

◆ STANDARD RATINGS

(Impedance at 20°C 100KHz/Qmax. Ripple current ; mAms/105°C 100KHz)

WV (Vdc)	Cap (uF)	CaSe size	Tan δ	Impedance	Ripple current	
		∅ D×L (mm)		(Ωmax)	(mAms)	
35 (1V)	33	5×11	0.12	0.57	200	
		6.3×9	0.12	0.74	180	
	56	6.3×11	0.12	0.21	350	
		8×9	0.12	0.27	310	
	150	8×12	0.12	0.13	660	
		10×9	0.12	0.17	590	
	220	8×16	0.12	0.086	850	
		10×13	0.12	0.08	870	
	270	8×20	0.12	0.069	1050	
		10×16	0.12	0.06	1230	
	370	10×20	0.12	0.046	1400	
		12.5×16	0.12	0.049	1450	
	560	10×25	0.12	0.042	1650	
		10×30	0.12	0.03	1920	
	680	12.5×20	0.12	0.035	1910	
		16×15	0.12	0.041	1950	
	1000	12.5×25	0.12	0.026	2230	
		12.5×30	0.12	0.024	2650	
	1200	16×20	0.12	0.028	2247	
		16×25	0.12	0.027	2530	
	1500	12.5×35	0.12	0.02	2880	
		12.5×40	0.12	0.017	3350	
	1800	16×25	0.12	0.021	2930	
		18×20	0.12	0.026	2860	
	2200	16×30	0.14	0.017	3450	
		18×25	0.14	0.019	3140	
	2700	16×35	0.14	0.015	3610	
		18×30	0.14	0.015	4170	
	3300	16×40	0.16	0.012	4100	
		18×35	0.16	0.014	4220	
	3900	18×40	0.16	0.011	4300	
	50 (1H)	22	5×12	0.10	0.68	190
			6.3×9	0.10	0.89	170
56		6.3×11	0.10	0.3	300	
		8×9	0.10	0.39	270	
100		8×12	0.10	0.17	560	
		10×9	0.10	0.22	500	
120		8×16	0.10	0.12	740	
		10×13	0.10	0.12	760	
180		8×20	0.10	0.09	910	
		10×16	0.10	0.084	1050	
270		10×20	0.10	0.058	1230	
		12.5×16	0.10	0.061	1260	
330		10×25	0.10	0.055	1440	
		10×30	0.10	0.043	1700	
470		12.5×20	0.10	0.045	1660	
		16×15	0.10	0.055	1690	
560		12.5×25	0.10	0.034	1960	
		12.5×30	0.10	0.03	2310	
820		12.5×35	0.10	0.025	2510	
		18×20	0.10	0.034	2210	
1000		12.5×40	0.10	0.021	2920	
		16×25	0.10	0.025	2560	
1200		18×20	0.10	0.036	2490	
		16×30	0.10	0.021	3010	
1500		18×25	0.10	0.026	2740	
		16×35	0.10	0.019	3150	
1800		16×40	0.10	0.016	3710	
		18×30	0.10	0.021	3640	
2200		18×35	0.12	0.017	3680	
		18×40	0.12	0.014	3800	
63 (1J)		15	5×11	0.09	0.88	165
			6.3×9	0.09	1.15	145
		33	6.3×12	0.09	0.35	265
	8×9		0.09	0.46	135	
	56	8×12	0.09	0.22	500	
		10×9	0.09	0.29	440	
	82	8×16	0.09	0.16	665	
		10×13	0.09	0.11	690	
	120	8×20	0.09	0.12	820	
		10×16	0.09	0.076	950	
	180	10×20	0.09	0.056	1150	
		12.5×16	0.09	0.072	1150	
	220	10×25	0.09	0.046	1350	
		12.5×20	0.09	0.041	1500	
	390	12.5×25	0.09	0.031	1900	
		12.5×30	0.09	0.028	2300	
	470	16×20	0.09	0.032	2000	
		12.5×35	0.09	0.024	2500	
	560	12.5×40	0.09	0.021	2800	
		16×25	0.09	0.025	2600	
	680	18×20	0.09	0.03	2500	
		16×30	0.09	0.021	2850	
	820	18×25	0.09	0.024	2800	
		16×35	0.09	0.019	2900	
	1000	16×40	0.09	0.018	3400	
		18×30	0.09	0.02	3300	
	1500	18×35	0.09	0.018	3400	
		18×40	0.09	0.017	3500	
	80 (1K)	68	10×13	0.08	0.17	480
			10×16	0.08	0.11	600
		120	10×20	0.08	0.084	800
			10×25	0.08	0.069	900
		150	12.5×16	0.08	0.11	750
12.5×20			0.08	0.062	1100	
220		12.5×25	0.08	0.047	1250	
		16×20	0.08	0.048	1350	
390		12.5×30	0.08	0.042	1500	
		12.5×35	0.08	0.036	1650	
470		16×25	0.08	0.038	1700	
		18×20	0.08	0.045	1500	
560		12.5×40	0.08	0.032	1800	
		16×30	0.08	0.032	1850	
680		18×25	0.08	0.036	1750	
	16×35	0.08	0.029	2000		
820	18×30	0.08	0.03	1900		
	16×40	0.08	0.027	2200		
1000	18×35	0.08	0.027	2200		
	18×40	0.08	0.026	2700		

LJ Series

◆ STANDARD RATINGS

(Impedance at 20°C 100KHz/Qmax. Ripple current; mAms/105°C 100KHz)

WV (Vdc)	Cap (uF)	CaSe size ∅ D×L (mm)	Tan δ	Impedance (Ωmax)	Ripple current (mAms)
100 (2A)	6.8	5×11	0.08	1.4	125
		6.3×9	0.08	1.9	110
	15	6.3×12	0.08	0.57	205
		8×9	0.08	0.75	180
	27	8×12	0.08	0.36	355
		10×9	0.08	0.45	310
	39	8×16	0.08	0.25	450
	47	10×13	0.08	0.17	480
	56	8×20	0.08	0.19	565
	68	10×16	0.08	0.11	600
	82	10×20	0.08	0.084	800
	100	12.5×16	0.08	0.11	750
	120	10×25	0.08	0.069	900
	150	12.5×20	0.08	0.062	1100
	220	12.5×25	0.08	0.047	1250
		16×20	0.08	0.048	1350
	270	12.5×30	0.08	0.042	1500
		12.5×35	0.08	0.036	1650
	330	16×25	0.08	0.038	1700
		18×20	0.08	0.045	1500
390	12.5×40	0.08	0.032	1800	
470	16×30	0.08	0.032	1850	
	18×25	0.08	0.036	1750	
560	16×35	0.08	0.029	2000	
	18×30	0.08	0.03	1900	
680	16×40	0.08	0.027	2200	
	18×35	0.08	0.027	2200	
820	18×40	0.08	0.026	2700	

WV (Vdc)	Cap (uF)	CaSe size ∅ D×L (mm)	Tan δ	Impedance (Ωmax)	Ripple current (mAms)
120 (2B)	10	6.3×11	0.12	6	85
	15	6.3×12	0.12	5	110
	18	8×9	0.12	4.5	125
	22	8×12	0.12	4	140
	33	8×16	0.12	3.5	245
		10×13	0.12	3.5	245
	47	8×20	0.12	2.8	300
		10×16	0.12	2.8	315
	56	10×16	0.12	2.5	315
	68	10×16	0.12	2.2	315
	82	10×20	0.12	2	330
	100	10×25	0.12	1.7	410
	120	12.5×20	0.12	1.5	470
	150	12.5×25	0.12	1.0	620
	220	13×30	0.12	0.85	760
		16×20	0.12	0.85	760
	270	16×25	0.12	0.6	860
		18×20	0.12	0.6	860
	330	16×30	0.12	0.46	930
		18×25	0.12	0.46	930
470	16×40	0.12	0.33	1035	
	18×30	0.12	0.33	1035	

物料编码原则 Part Number System

1	2	3	4	5	6	7	8	9	10	11	12	13	14	15	16	17
E	R	G	2	D	1	5	0	M	1	0	1	3	0	0	Y	
①	②		③		④			⑤	⑥			⑦		⑧	⑨	
分类	系列		电压		容量			误差	直径		高度		引脚		颜色	其他
Category	Series		Voltage		Capacitance			Tol.	Dia.		Length		Terminal		Colour	Other

①分类Category

编码Code	代码Code	种类Type	备注Remark
1	E	Electrolytic Capacitor	铝电解电容
	P	Conductive Polymer	导电高分子固体铝
	S	super-capacitor	超级电容

②系列Series			③电压Voltage			④容量Capacitance			⑤Tolerance		尺寸Size	⑥尺寸Size				⑦引脚Terminal		
系列series	编码Code		电压WV	编码Code		容量Cap	编码Code			容量误差Tolerance		编码Code	直径编码Dia. Code		高度编码Length Code		形式Specification	编码Code
	2	3		4	5		6	7	8				9	10	11	12		
SM	S	M	4	0	G	0.1	R	1	0	-5~+5	J	3×5	0	3	0	5	Bulk packing	00
SS	S	S	6.3	0	J	0.22	R	2	2	-10~+10	K	4×5	0	4	0	5	Φ4-18 Taping	T1
NP	N	P	10	1	A	0.33	R	3	3	-20~+20	M	5×5	0	5	0	5		T2
LL	L	L	16	1	C	0.47	R	4	7	-5~+20	F	6.3×5	0	6	0	5		T3
RD	R	D	25	1	E	1	1	R	0	-10~+20	V	4×7	0	4	0	7		T4
RE	R	E	35	1	V	2.2	2	R	2	-10~+30	Q	5×7	0	5	0	7	Lead Cut	F
RT	R	T	40	1	G	3.3	3	R	3	-20~+0	S	6.3×7	0	6	0	7		C
RF	R	F	50	1	H	4.7	4	R	7	-0~+20	A	8×7	0	8	0	7		R
RG	R	G	55	1	I	6.8	6	R	8			5×11	0	5	1	1		Y
RJ	R	J	63	1	J	10	1	0	0			6.3×11	0	6	1	1		M
RR	R	R	70	1	L	22	2	2	0			8×12	0	8	1	2		X
LF	L	F	80	1	K	33	3	3	0			8×16	0	8	1	6		Z
LJ	L	J	100	2	A	47	4	7	0			10×12	1	0	1	2		K
LR	L	R	120	2	B	100	1	0	1			10×16	1	0	1	6		
LG	L	G	140	2	L	220	2	2	1			8×20	0	8	2	0		
RS	R	S	160	2	C	330	3	3	1			10×20	1	0	2	0		
RN	R	N	180	2	Q	470	4	7	1			13×20	1	3	2	0		
RV	R	V	200	2	D	560	5	6	1			13×25	1	3	2	5		
LH	L	H	220	2	N	1000	1	0	2			16×25	1	6	2	5		
TE	T	E	250	2	E	1500	1	5	2			16×32	1	6	3	2		
TF	T	F	300	2	S	2200	2	2	2			16×36	1	6	3	6		
TG	T	G	315	2	F	3300	3	3	2			18×32	1	8	3	2		
LP	L	P	350	2	V	4700	4	7	2			18×36	1	8	3	6		
LT	L	T	385	2	P	6800	6	8	2			18×40	1	8	4	0		
LS	L	S	400	2	G	10000	1	0	3									
LV	L	V	420	2	T	15000	1	5	3									
			450	2	W	22000	2	2	3									
			500	2	H	33000	3	3	3									
			550	2	J	56000	5	6	3									
			600	2	K	68000	6	8	3									

⑧颜色代码 Colour Code

编码Code	颜色	黑色	黄色	墨绿色	淡绿色	橙色	白色	紫色
16	Colour	Black	Yellow	Ink Green	Light Green	Orange	White	Purple
	代码Code	B	Y	I	L	O	W	P

⑨特殊代码 Other

用于标记客户特殊要求

Used to mark special requirements of customers

焊接温度及注意事项 Solder temperature and notes

●无铅波峰焊 Ware soldering(lead-free)

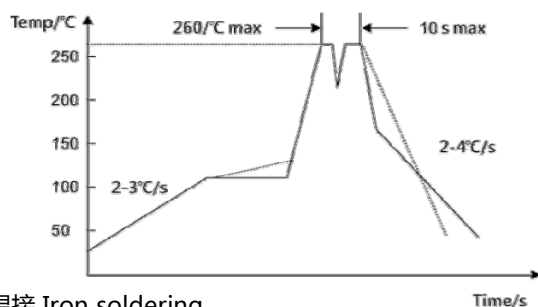

注意事项 notes:

- ①PCB主面预热温度最高升温斜率:2→3°C / sec, 预热时长:120s左右;
- ②PCB主面预热温度范围:90-130°C;
- ③PCB背面最高预热温度不超过130°C;
- ④波峰温度与预热区温度落差不能大于150°C;
- ⑤波峰焊锡炉温度应控制在250-260°C 之间;
- ⑥波谷温度最好不能低于217°C, 也就是说如果是双波峰, 两个波峰之间落差不能大于60度, 以防造成二次焊接;
- ⑦焊接时间:双波波峰"1"控制在0.5-2s 之间, 波峰"11"的时间控制在1.5-4s 之间, 合计时间:2-6s. 单波时间控制在2-6s.
- ⑧冷却区斜率一般指从最高温降到90°C时间平均负斜率-4→-2°C/s

●烙铁焊接 Iron soldering

烙铁作业:最高温度: 350 ± 5°C, 焊接时间: 3±0.5 秒

Lead Forming

Taping Specifications

Fig.1 Code:T1

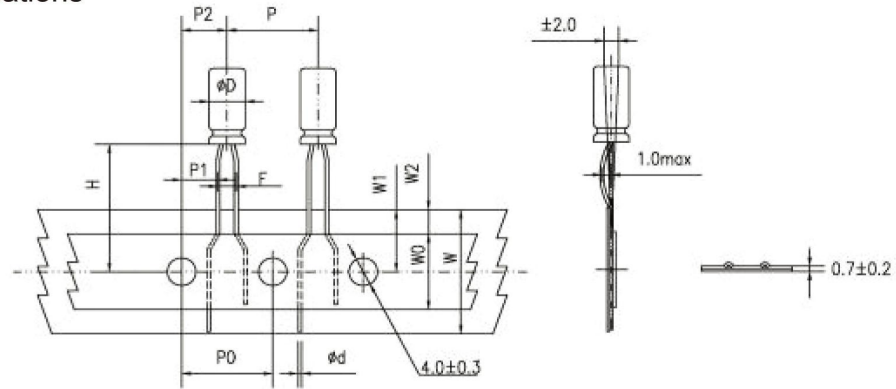

Fig.2 Code:T2

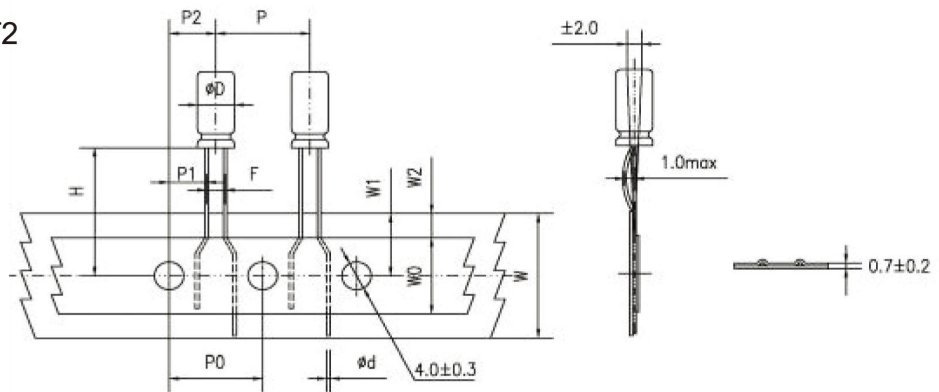

Fig.3 Code:T2

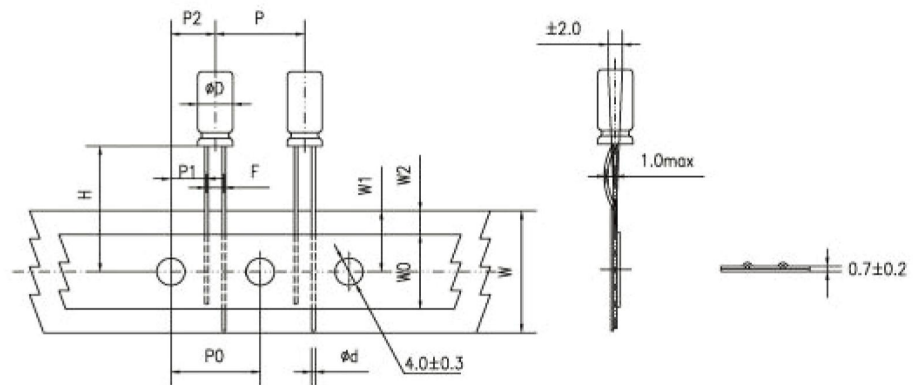
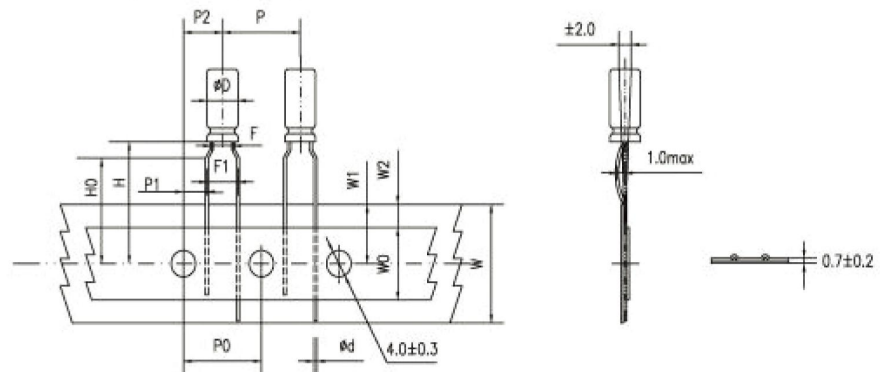

Fig.4 Code:T3



Specification Fig.1 & Fig.2 & Fig.3

Items	Symbol	CASE SIZE											Tolerance		
		4 × 5 4 × 7		5 × 5 5 × 7		5x11		6.3x5	6.3x7 6.3x9	6.3x11 6.3x12	8x5/7 8x9/11 8x11.5 8x12	8x16 8x20		10x9/12 10x12.5 10x13/16 10x20/25	
Pin Code		T ₁	T ₂	T ₁	T ₂	T ₁		T ₂	T ₂	T ₂	T ₂	T ₂	T ₂		
Lead wire diameter	φd	0.45		0.45		0.5		0.45	0.5	0.5	0.5	0.45/0.5	0.6	0.6	± 0.05
Pitch of body	P	12.7		12.7		12.7		12.7	12.7	12.7	12.7	12.7	12.7	12.7	± 1.0
Feed hole pitch	PO	12.7		12.7		12.7		12.7	12.7	12.7	12.7	12.7	12.7	12.7	± 0.2
Hole center to lead distance	P1	5.1	5.6	5.1	5.35	5.1	5.35	5.1	5.1	5.1	5.1	4.6	4.6	3.85	± 0.7
Feed hole center to body center distance	P2	6.35		6.35		6.35		6.35	6.35	6.35	6.35	6.35	6.35	6.35	± 1.0
Lead to lead distance	F	2.5	1.5	2.5	2.0	2.5	2.0	2.5	2.5	2.5	2.5	3.5	3.5	5.0	± 0.5
Height of body from tape center	H	18.5		18.5		18.5		18.5	18.5	18.5	18.5	18.5	18.5	18.5	± 0.75
Base tape width	W	18.0		18.0		18.0		18.0	18.0	18.0	18.0	18.0	18.0	18.0	± 0.5
Adhesive tape width	WO	11.0		11.0		11.0		11.0	11.0	11.0	11.0	11.0	11.0	11.0	min
Hole positron	W1	9.0		9.0		9.0		9.0	9.0	9.0	9.0	9.0	9.0	9.0	+0.75 -0.5
Hole down tape position	W2	3.0		3.0		3.0		3.0	3.0	3.0	3.0	3.0	3.0	3.0	max

Specification Fig.4

Items	Symbol	CASE SIZE									Tolerance
		4 × 5 4 × 7	5 × 5	5 × 7	5 × 11	6.3 × 5	6.3 × 7 6.3 × 9	6.3 × 11 6.3 × 12	8 × 5/7 8 × 9/11 8 × 11.5/12	8 × 16 8 × 20	
Pin Code		T ₃	T ₃	T ₃	T ₃	T ₃	T ₃	T ₃	T ₃	T ₃	
Lead wire diameter	φd	0.45	0.45	0.45	0.5	0.45	0.5	0.5	0.45/0.5	0.6	± 0.05
Pitch of body	P	12.7	12.7	12.7	12.7	12.7	12.7	12.7	12.7	12.7	± 1.0
Feed hole pitch	PO	12.7	12.7	12.7	12.7	12.7	12.7	12.7	12.7	12.7	± 0.2
Hole center to lead distance	P1	3.85	3.85	3.85	3.85	3.85	3.85	3.85	3.85	3.85	± 0.7
Feed hole center to body center distance	P2	6.35	6.35	6.35	6.35	6.35	6.35	6.35	6.35	6.35	± 1.0
Lead to lead distance	F	1.5	2.0	2.0	2.0	2.5	2.5	2.5	3.5	3.5	± 0.5
Lead to lead distance	F1	5.0	5.0	5.0	5.0	5.0	5.0	5.0	5.0	5.0	+0.8 -0.2
Height of body from tape center	H	18.5	18.5	18.5	18.5	18.5	18.5	18.5	18.5	18.5	± 0.75
Lead wire clinch height	HO	16.0	16.0	16.0	16.0	16.0	16.0	16.0	16.0	16.0	± 0.5
Base tape width	W	18.0	18.0	18.0	18.0	18.0	18.0	18.0	18.0	18.0	± 0.5
Adhesive tape width	WO	11.0	11.0	11.0	11.0	11.0	11.0	11.0	11.0	11.0	min
Hole position	W1	9.0	9.0	9.0	9.0	9.0	9.0	9.0	9.0	9.0	+0.75 -0.5
Hole down tape position	W2	3.0	3.0	3.0	3.0	3.0	3.0	3.0	3.0	3.0	max

● Lead Forming & Cut:

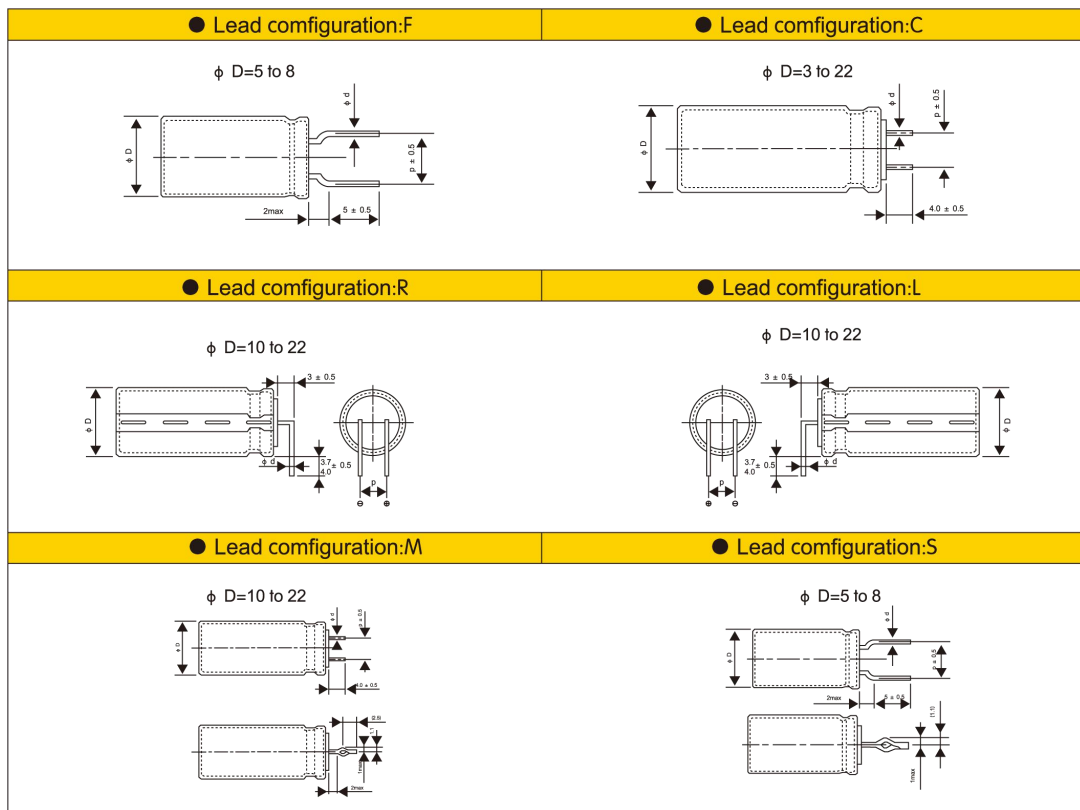

● LEAD SPACING&RECOMMENDED PCB DIMENSIONS

(mm)

Dimension	φD	φd	p	PC Board		Lead Configuration
				Hole diameter	Thickness	
5		0.5	5.0	0.8	1.6	F C S
6.3		0.5	5.0	0.8		
8		0.5/0.6	5.0	1.0		
10		0.6	5.0	1.0	1.6	C M R L
12.5		0.6	5.0	1.0		
16		0.8	7.5	1.2		
18		0.8	7.5	1.2		
20		0.8	7.5	1.2		
22		0.8	10.0	1.2		

● Lead configuration: B

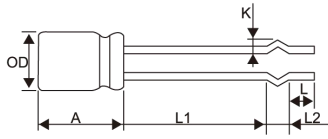

∅D	L1	L2	K	A	L	
5	17.5-19.5	2.6	1.9	10.0-15.0	3.0-5.0	
6.3	17.5-19.5	2.6	1.9	10.0-16.0		
8	12.0-14.0	2.5	1.3	10.0-20.0		
8	13.5-15.5	2.5	1.5			
8	13.0-15.0	3.0	1.5			
8	19.5-21.5	3.0	1.5			
8	21.0-23.0	3.0	1.5			
10	7.5-9.5	2.5	1.7	10.0-25.0		
10	17.0-19.0	2.5	1.7			
10	10.5-12.5	2.5	1.5			
10	10.0-12.0	3.0	1.5			
10	13.0-15.0	3.0	1.5			
10	18.0-20.0	3.0	1.5			
10	21.0-23.0	3.0	1.5			
	± 1.0	± 0.5	0.3	± 1.0		± 1.0

● Lead configuration: K

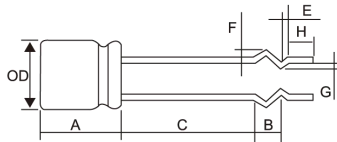

∅D	C	B	E	F	G	A	H
8	13.5-15.5	3	1.2	1.8	0.8	10-20	3.0-5.0
10	18.5-20.5	3	1.2	1.8	1	10-25	
10	19.0-21.0	3	1.5	1.4	0.5		
	± 1.0	± 0.5	± 0.3	± 0.3	± 0.3	± 1.0	± 1.0

■ 概述 Scope

本规范规定了所有系列径向引线引出铝电解电容器的技术规范。

This specification covers "ALL series" miniature single-ended aluminium electrolytic capacitors.

■ 参考标准 Standard

本承认书参考 JIS-C-5101-1 和 JIS-C-5101-4 制定

This approval sheet consulted the institute of JIS-C-5101-1 and JIS-C-5101-4.

■ 工作温度范围 Operating temperature range

工作温度范围是电容器在施加额定工作电压条件下，可以长期可靠工作的环境温度范围。

Operating temperature range is the range of ambient temperature at which the capacitor can be operated continuously at rated

■ 测试环境 Condition of test

如果没有其他规定，标准的测试、检验环境条件如下所示：

环境温度：15℃~35℃

相对湿度：25%~75%

大气压力：86kPa~106kPa

如果对测试结果有异议，可以在以下条件测试：

环境温度：20±1℃

相对湿度：60%~67%

大气压力：86kPa~106kPa

Unless otherwise specified, the standard range of atmospheric conditions for making measurements and tests are as follows:

Ambient temperature : 15°C to 35°C

Relative humidity : 25% to 75% A

ir pressure: 86kPa to 106kPa

If there may be doubt on the results, measurements shall be made within the following limits:

Ambient temperature : 20±1°C

Relative humidity: 60% to 67%

Air pressure : 86kPa to 106kPa

■ 试验方法及要求 Tests

项目 Item	试验条件 Test Conditions	性能要求 Performance	
浪涌电压 Surge Voltage	温度 15~35℃，施加额定浪涌电压，充电 30 秒，放电 5 分 30 秒，共循环 1000 次。 At 15~35℃, applying Surge Voltage 1000 cycles of 30s on and 330s off.	无可见损伤 No visible damage	
		ΔC/C	≤± 10 %
		tgδ	≤初始规定值 Not more than specified value
		I	≤初始规定值 Not more than specified value
耐久性 Load Life	额定温度下,施加额定电压(直流电压值+交流电压峰值≤标称电压)规格时间,恢复 16 小时后: After applying rated voltage (Voltage+peak ripple voltage ≤Rated voltage)specified times at rated temperature and then resumed 16 hours.	± 20 %初始测量值以内 Within ± 20 % of initial value	
		ΔC/C	± 20 %初始测量值以内 Within ± 20 % of initial value
		tgδ	≤200%初始规定值 Not more than 200% of specified value
		I	≤初始规定值 Not more than specified value
贮存 Shelf Life	105℃, 1000 小时。试验后: 恢复24小时 施加额定电压 30 分钟后 1000 hours at +105℃.After test:UR to be applied for 30min >24h before measurement.	± 20 %初始测量值以内 Within ± 20 % of initial value	
		ΔC/C	± 20 %初始测量值以内 Within ± 20 % of initial value
		tgδ	≤200%初始规定值 Not more than 200% of specified value
		I	≤200%初始规定值 Not more than 200% of specified value
可焊性 Solderability	焊料槽温度为 235±5℃, 浸渍深度占整个引出线的 90%, 浸渍持续时间为 2 秒。 Tank temperature : 235±5℃; Impregnating depth:≥90% of the total lead wire; Impregnating depth:2s.	引出端的镀层良好, 焊料自由流动, 引出端湿润。浸渍面积 90%以上附着焊锡 The lead wire is coated by tin and wet. At least 90% of Circumferential surface of the dipped portion of termination shall be covered with new solder	
耐焊接热 Resistance to soldering heat	方法: 焊料槽温度为260±5℃, 浸渍深度 6mm 浸渍持续时间为 10 秒。 Tank temperature:260±5℃; Impregnating depth:6mm; Impregnating time:10s.	无可见损伤 No visible damage	
		ΔC/C	≤± 10 %
		tgδ	≤初始规定值 Not more than specified value
		I	≤初始规定值 Not more than specified value
稳态湿热 Stable Humidity	试验温度:+40℃,湿度:90~95%,不施加电压21天 21 days at 40℃,RH 90 to 95%, no voltage applied.	无可见损伤和电解液漏出, 且标志清晰 No visible damage; no leakage of electrolyte; marking legible	
		ΔC/C	≤± 5 %
		tgδ	≤初始规定值 Not more than specified value
		I	≤初始规定值 Not more than specified value
耐振性 Resistance to vibration	频率: 10-55-10 Hz/分 Frequency :From 10 to 55 Hz and return to 10 Hz,shall be transferred in 1 Min Total Amplitude: 1.5 mm 条件: X. Y. Z 方向各2小时 Direction and duration of vibration :3 orthogonal directions mutually each for 2 hours Total 6 hours.	无可见损伤和电解液漏出, 且标志清晰 No visible damage; no leakage of electrolyte; marking legible	
		ΔC/C	≤± 5 %

■ 试验方法及要求 Tests

项目 Item	试验条件 Test Conditions	性能要求 Performance																								
高低温特性 Characteristic at High and low temperature	<p>电容器根据下表的次序处理 The capacitor shall be subjected in turn to the procedures specified below.</p> <table border="1"> <thead> <tr> <th>阶段 Step</th> <th>温度 Temperater</th> <th>时间 Time</th> </tr> </thead> <tbody> <tr> <td>1</td> <td>20±2℃</td> <td>热平衡状态 thermal stability</td> </tr> <tr> <td>2</td> <td>-40℃</td> <td>*2 hours</td> </tr> <tr> <td>3</td> <td>20±2℃</td> <td>热平衡状态 thermal stability</td> </tr> <tr> <td>4</td> <td>105℃</td> <td>*2 hours</td> </tr> <tr> <td>5</td> <td>20±2℃</td> <td>热平衡状态 thermal stability</td> </tr> </tbody> </table> <p>*电容器放置在每一温度下，待阻抗或电容量稳定后方可测试 *The capacitor should be stored at each temperature until measured impedance are stabilized.</p> <p>阶段 1: 测定阻抗值 Step 1: Measured impedance.</p> <p>阶段 2: 放置 2 小时后，达到热平衡状态再测。 Step 2 : After the capacitor being stored for 2 hours, impedance shall be Measured. The measurement shall be made at thermal stability.</p> <p>阶段 4: 放置 2 小时后，达到热平衡状态再测 Step 4 : After the capacitor being stored for 2 hours, Leakage Current shall be Measured. The measurement shall be made at thermal stability.</p>	阶段 Step	温度 Temperater	时间 Time	1	20±2℃	热平衡状态 thermal stability	2	-40℃	*2 hours	3	20±2℃	热平衡状态 thermal stability	4	105℃	*2 hours	5	20±2℃	热平衡状态 thermal stability	<table border="1"> <tbody> <tr> <td>阶段 2 Step 2</td> <td>阻抗比(对阶段 1) Impedance ratio</td> <td>≤3</td> </tr> <tr> <td>阶段 4 Step 4</td> <td>漏电流 Leakage Current</td> <td>≤10 倍规定值 Not more than 1000% of specified value</td> </tr> </tbody> </table>	阶段 2 Step 2	阻抗比(对阶段 1) Impedance ratio	≤3	阶段 4 Step 4	漏电流 Leakage Current	≤10 倍规定值 Not more than 1000% of specified value
阶段 Step	温度 Temperater	时间 Time																								
1	20±2℃	热平衡状态 thermal stability																								
2	-40℃	*2 hours																								
3	20±2℃	热平衡状态 thermal stability																								
4	105℃	*2 hours																								
5	20±2℃	热平衡状态 thermal stability																								
阶段 2 Step 2	阻抗比(对阶段 1) Impedance ratio	≤3																								
阶段 4 Step 4	漏电流 Leakage Current	≤10 倍规定值 Not more than 1000% of specified value																								
耐溶剂性 Resisting Solvent	溶剂: 异丙醇 Solvent :Isopropylalcohol 温度: 20-25℃ 时间 : 30±5s Temperature: 20-25℃ Time : 30±5s	外观: 无显著异常 Appearance :No remarkable abnormality																								

■ 试验方法及要求 Tests

项目 Item	试验条件 Test Conditions	性能要求 Performance																								
端子强度 Terminal Strength	<p>抗拉强度: 沿电容器端子引线方向施加拉力(如下表), 10±1 秒</p> <table border="1"> <tr> <td>引线直径Φ</td> <td>0.45</td> <td>0.5</td> <td>0.6</td> <td>0.8</td> <td>1</td> </tr> <tr> <td>拉力N</td> <td colspan="2">5</td> <td colspan="2">10</td> <td>20</td> </tr> </table> <p>Tensile strength of terminal: A static load(stated in the table above)shall be applied to the terminal in the axial direction and acting in a direction away from the body for 10±1 sec..</p> <p>端子抗弯强度: 在电容器引线施加固定重力(如下表), 然后将电容体弯折 90°后回到原位, 再向相反方向弯折 90°后回到原位。上述过程在 5 秒内完成。</p> <table border="1"> <tr> <td>引线直径Φ</td> <td>0.45</td> <td>0.5</td> <td>0.6</td> <td>0.8</td> <td>1</td> </tr> <tr> <td>拉力N</td> <td colspan="2">2.5</td> <td colspan="2">5</td> <td>10</td> </tr> </table> <p>Bending strength of terminal: Hang the specified dead weight(stated in the table above),then bend the body through 90°, return to the original position. Next bend it in opposite direction through 90° with the same speed,again return to the original position. Complete this operation in about 5 sec.</p>	引线直径Φ	0.45	0.5	0.6	0.8	1	拉力N	5		10		20	引线直径Φ	0.45	0.5	0.6	0.8	1	拉力N	2.5		5		10	<p>测定静电容量时, 无接触不良, 开路和短路现象, 另外无机械损伤和端子损伤。 When the capacitance is measured ,there shall be no intermittent contacts or open –or short –circuting . There shall be no such mechanical damage etc. as terminal damage</p>
引线直径Φ	0.45	0.5	0.6	0.8	1																					
拉力N	5		10		20																					
引线直径Φ	0.45	0.5	0.6	0.8	1																					
拉力N	2.5		5		10																					
压力释放 Pressure relief	<p>直流试验 D.C. test 施加同额定电压相等的反电压。 Reversed polarity D.C. rated voltage shall be applied to the capacitor.</p> <p>注: 1. 试验开始 30 Min 后,防爆装置不动作时,停止试验。 2. 该规定适用于铝壳直径6.3mm 以上的电容器。 Note: 1. When the pressure relief device does not open even 30 min after commencement of this test, the test may be ended. 2. This requirement applies to capacitors with a diameter of 6.3mm or more</p>	<p>防爆装置释放时, 无燃烧、无爆炸或铝壳和封口材料的分离。 The pressure relief device shall open in such a way as to avoid any danger of fire or explosion of Capacitor elements .</p>																								

提示: Notes:

*温度系数不应用在寿命计算公式中,只能作为参考

Temperature coefficient is not used in life formula but for reference.

*每升高5℃,纹波电流产生的温升使电容器的使用寿命减半,从而降低电容器的使用寿命.当实际使用中需延长寿命性能时,必须降低rms纹波电流。

The endurance of capacitors is reduced with internal heating produced by ripple current at the rate of halving the lifetime with every 5°C rise.

When long life performance is required in actual use, the rms ripple current has to be reduced.

■铝电解电容器的使用注意事项 Guidelines For Using Aluminum Electrolytic Capacitor

为使您获得电解电容器的最佳性能和延长电解电容器的使用寿命，在使用电解电容器前，请务必阅读本注意事项。

Upon using Aluminum Electrolytic Capacitors, please proper handing and observing to following important points will insure optimum capacitor performance and long life.

①直流电解电容器是有极性的.DC electrolytic capacitors are polarized.

确定极性，极性标志在电容器的基体上。以免因极性反可能引起电路短路或电容器损坏，当极性不固定或不确定的，使用 双极性电容器。

注意直流电解电容器不能使用于交流。

Make sure of the polarity .The polarity is marked on the body of the capacitor .Application of the reversed voltage cause a short circuit or damage to the capacitor .

Use bipolar capacitors when the polarity is not determined or unknown . Note that DC electrolytic capacitors can not be used for AC application .

②使用电压不要大于额定电压.Do not apply voltage greater than rated voltage .

使用电压大于额定电压，漏电流会增大，可能损坏电容器。建议工作电压为额定电压的70~80%，电容器在建议的工作电压下使用可延长电容器的寿命。

IF a voltage exceeding the rated voltage is applied ,the leakage current will increase , which damage the capacitor . Recommended working voltage is 70 to 80 percent of tatted voltage . Using capacitors at recommended working voltage prolongs capacitor life .

③不要使过大的纹波电流通过电容器.Do not allow excessive ripple current through the capacitor .

流过电容器的纹波电流超过许可值，将会引起电容器发热，电容量减少，损害电容器。通过电容器的纹波电流不要大于允许值。

The flow of ripple current over permissible ripple current will cause heat of the capacitor ,which may decrease the capacitance and damage the capacitor .

ripple current on the capacitor must be at or bellow allowable level .

④快速的充放电电路中,使用专门设计的电容器.Use specially designed capacitors for the circuits where charge and discharge are frequency repeated .

在经受快速的周期性充放电电路中，电容器可能受损害，它的寿命因容量下降、温升等原因而缩短，在这种电路中，一定要使用专门设计的电容器。

In the circuit subjected to rapid charge cycles ,capacitors may be damaged ,its life may be shortened by capacitance decrease ,heat rise , ect .

Be sure and use special capacitors in these applications .

⑤工作温度范围.Operating temperature range .

电容器的特性随工作温度而变化，在温度较高的情况下，容量、漏电流增大， $tg\delta$ 减少；在低温情况下，容量和漏电流下降， $tg\delta$ 增大。

电容器在较低的温度下使用会确保延长寿命。

The characteristics of capacitors change with the operating temperature .The capacitance and leakage current increase and decrease at higher temperatures .

The capacitance and leakage current decrease and $tg\delta$ increase lower temperature .Usage at lower temperature will ensure longer life .

⑥核对工作频率.Check operating frequency .

电解电容器的容量通常是在 100Hz 或 120Hz 下测得的。然而要记住容量随频率的升高而下降， $tg\delta$ 随频率的升高而增大，并使周围温度升高。

The capacitance of electrolytic capacitors is usually measured at 100Hz or 120Hz . However , remember that capacitance decrease and $tg\delta$ increase as the applied frequency becomes higher whereas the ambient temperature becomes higher .

⑦长时间存放的电容器，在使用前加额定直流电压处理. Apply rated DC voltage treatment to the capacitors which have been stored for a long time

长时间的存放，实际对电容器的容量和 $tg\delta$ 没有多大的影响，然而往往会使漏电流增大，耐压降低。长时间存放后的电容器处理，首先逐渐施加直流电压至额定电压，然后再使用。

Long periods of storage have virtually no effect no a capacitor's capacitance and $tg\delta$.Such periods tend however ,to increase leakage current and decrease

withstand voltage .After removing capacitors from long-duration storage ,first apply a gradually increasing DC voltage to rated voltage and then use them.

⑧电容器外壳与阴极端是不绝缘的.The capacitor case is not insulated from the cathode terminal .

电容器外壳与阴极端是通过电解液连接的，如果电容器的外壳必须与线路绝缘，则电容器的安装位置处，一定要采取绝缘出措施。

The capacitor's case and cathode terminal connect through the electrolyte.If the case is to be completely insulated,that insulation must be at the capacitor's mounting point.

⑨电容器的端子或引线上不要施加过大的力.Do not apply excessive force to the terminals and leads.

过大的力施加到端子和引线上，可能引起引线的断裂或端子分裂，转而会引起内部连接的破坏。

The excessive strong force applied to the terminals and lead wires may cause leads to break or terminals to separate and ,in turn ,cause the internal contact to fail.

⑩关于焊接以后的清洗. Cleaning after soldering

① 电容器不能用卤化有机物系列的清洗剂进行清洗。如果必须进行清洗，请使用能够保证电容器质量的清洗剂。

The aluminum electrolytic capacitors should be free of halogenated solvents during board cleaning after soldering. Use solvent proof capacitors when halogenated solvents are used.

② 请不要让固定剂及镀层（涂层剂）将电容器封口部位（端子一侧）全部封住。

Do not cover up all the sealing area of capacitors with adhesives、fixative or coating materials (coating agent), make coverage only partial.

X-ON Electronics

Largest Supplier of Electrical and Electronic Components

Click to view similar products for [Aluminium Electrolytic Capacitors - Radial Leaded](#) category:

Click to view products by [TOPAZ](#) manufacturer:

Other Similar products are found below :

[LXY50VB4.7M-5X11](#) [RFO-100V471MJ7P#](#) [ECE-A1EGE220](#) [B41041A7226M8](#) [B41044A7157M6](#) [NCD681K10KVY5PF](#)

[NEV1000M25EF-BULK](#) [NEV100M35DC](#) [NEV100M63DE](#) [NEV220M25DD-BULK](#) [NEV.33M100AA](#) [NEV4700M50HB](#) [NEV.47M100AA](#)

[NEVH1.0M250AB](#) [NEVH3.3M250BB](#) [NEVH3.3M450CC](#) [KME50VB100M-8X11.5](#) [SG220M1CSA-0407](#) [ES5107M016AE1DA](#)

[ESMG160ETD102MJ16S](#) [ESX472M16B](#) [227RZS050M](#) [476CKH100MSA](#) [477RZS050M](#) [B41793A9108Q1](#) [UVX1V101KPA1FA](#)

[UVX1V222MHA1CA](#) [KME25VB100M-6.3X11](#) [VTL100S10](#) [VTL470S10](#) [VTL470S16A](#) [511D336M250EK5D](#) [052687X](#) [ECE-A1CF471](#)

[NRE-S560M16V6.3X7TBSTF](#) [RGA221M1CTA-0611G](#) [ERZA630VHN182UP54N](#) [UPL1A331MPH](#) [NEV1000M6.3DE](#) [NEV100M16CB](#)

[NEV100M50DD-BULK](#) [NEV2200M16FF](#) [NEV220M50EE](#) [NEV2.2M50AA](#) [NEV330M63EF](#) [NEV4700M35HI](#) [NEV4.7M100BA](#)

[NEV47M16BA](#) [NEV47M50CB-BULK](#) [NEVH1.0M350AB](#)