

规格書

SPECIFICATION

Customer : 深圳市立創電子商務有限公司

Part Name: E-CAP

SPEC : RE Series

Part NO. : ALL

Date : 2021-7-24

CUSTOMER SIGN		

TOPAZCON	
DRAWING	RATIFY
李梦如	<i>Cock</i>

RE Series



- Standard series for general purpose
- Wide temperature range from -40°C ~ $+105^{\circ}\text{C}$
- Endurance: $+105^{\circ}\text{C}$ 2,000hours
- RoHS Compliant

● SPECIFICATIONS

Items	Characteristics												
Category	-40 to + 105 °C (6.3 to 100Vdc)						-25 to +105 °C (160 to 500Vdc)						
Temperature Range													
Rated Voltage Range	6.3 to 500Vdc												
Capacitance Tolerance	$\pm 20\%$ (M) (at 20 °C , 120Hz)												
Leakage Current	6.3 to 100Vdc						160 to 500Vdc						Where, I: Max.leakage current(μA), C: Nominal capacitance(μF) V: Rated voltage(V) (at 20 °C)
	$1 \leq 0.03CV$ or $4 \mu\text{A}$ (at 1 minute) $1 \leq 0.01CV$ or $3 \mu\text{A}$ (at 2 minutes) Whichever is greater						CV		After 1 minute		After 5 minutes		
							$CV \leq 1.000$		$1 \leq 0.1CV+40 \mu\text{A}$		$1 \leq 0.03CV+15 \mu\text{A}$		
						$CV > 1.000$		$1 \leq 0.04CV+100 \mu\text{A}$		$1 \leq 0.02CV+25 \mu\text{A}$			
Dissipation Factor (tan δ)	Rated voltage(Vdc)	6.3	10	16	25	35	50	63	100	160-250	350-400	450	500
	tan δ (Max)	0.26	0.19	0.16	0.14	0.12	0.10	0.09	0.08	0.20	0.24	0.24	0.24
	When nominal capacitance exceeds 1,000 μF , add 0.02 to the value above for each 1,000 μF increase. (at 20 °C , 120Hz)												
Low Temperature Characteristics (Max.Impedance Ratio)	Rated voltage(Vdc)	6.3	10	16	25	35	50	63	100	160-250	350-400	450	
	Z(-25 °C)/Z(+20 °C)	5	4	3			2			3	6	6	
	Z(-40 °C)/Z(+20 °C)	12	10	8	5	4		3			-	-	
Endurance	The following specification shall be satisfied when the capacitors are restored to 20 °C after subjected to DC voltage with the rated ripple current is applied for 2,000 hours at 105 °C												
	Capacitance change	$\leq \pm 20\%$ of the initial value											
	D.F. (tan δ)	$\leq 200\%$ of the initial specified value											
	Leakage current	\leq The initial specified value											
Shelf Life	The following specification shall be satisfied when the capacitors are restored to 20 °C after exposing them for 1,000 hours at 105 °C ,without voltage applied												
	Capacitance change	$\leq \pm 20\%$ of the initial value											
	D.F.(tan δ)	$\leq 200\%$ of the initial specified value											
	Leakage current	$\leq 200\%$ The initial specified value											

● DIMENSIONS[MM]

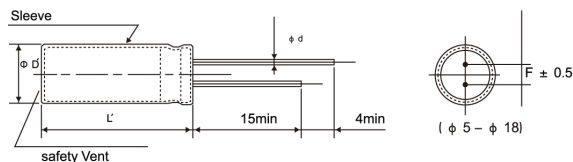

Φ D	5	6.3	8	10	12.5	16	18
Φ d	0.5	0.5	0.5	0.6	0.6	0.8	0.8
F	2.0	2.5	3.5	5.0	5.0	7.5	7.5
Φ D'	Φ D+0.5max						
L'	L+2max						

● RATED RIPPLE CURRENT MULTIPLIERS

Frequency correction factor for ripple current

Cap(μF)	50	120	300	1k	10k	100k
Cap < 10	0.65	1.00	1.35	1.75	2.30	2.50
10 ≤ Cap < 100	0.75	1.00	1.25	1.50	1.75	1.80
100 ≤ Cap ≤ 1000	0.80	1.00	1.15	1.30	1.40	1.50
Cap > 1000	0.85	1.00	1.03	1.05	1.08	1.08

The endurance of capacitors is shorted with internal heating produced by ripple current at the rate of halving the lifetime with every 5 °C rise. When long life performance is required in actual use, the rms ripple current has to be reduced

RE Series

● STANDARD RATINGS

WV (Vdc)	Cap (μ F)	Case size Φ D × L(mm)	tan δ	Ripple current (mA rms/105 °C, 120Hz)
6.3(OJ)	33	5 × 11	0.26	54
	47	5 × 11	0.26	64
	100	5 × 11	0.26	94
	220	5 × 11	0.26	140
	330	6.3 × 11	0.26	190
	470	6.3 × 11	0.26	230
	1000	8 × 11.5	0.26	380
	2200	10 × 20	0.28	710
	3300	10 × 20	0.30	840
	4700	12.5 × 20	0.32	1090
	6800	12.5 × 25	0.36	1350
	10000	16 × 25	0.44	1650
	15000	16 × 35	0.54	2010
	22000	18 × 40	0.68	2350
10(1A)	22	5 × 11	0.19	46
	33	5 × 11	0.19	57
	47	5 × 11	0.19	68
	100	5 × 11	0.19	100
	220	6.3 × 11	0.19	170
	330	6.3 × 11	0.19	200
	470	8 × 11.5	0.19	250
	1000	10 × 12	0.19	460
	2200	10 × 20	0.21	760
	3300	12.5 × 20	0.23	1000
	4700	12.5 × 25	0.25	1260
	6800	16 × 25	0.29	1570
	10000	16 × 35	0.37	1890
	15000	18 × 35	0.47	2180
16(1C)	10	5 × 11	0.16	34
	22	5 × 11	0.16	51
	33	5 × 11	0.16	63
	47	5 × 11	0.16	75
	100	5 × 11	0.16	110
	220	6.3 × 11	0.16	182
	330	8 × 11.5	0.16	260
	470	8 × 11.5	0.16	310
	1000	10 × 16	0.16	560
	2200	12.5 × 20	0.18	920
	3300	12.5 × 25	0.20	1170
	4700	16 × 25	0.22	1480
	6800	16 × 30	0.26	1780
	10000	18 × 35	0.34	2080
25(1E)	4.7	5 × 11	0.14	25
	10	5 × 11	0.14	36
	22	5 × 11	0.14	54
	33	5 × 11	0.14	67
	47	5 × 11	0.14	80
	100	6.3 × 11	0.14	130
	220	8 × 11.5	0.14	230
	330	8 × 11.5	0.14	310
	470	10 × 12	0.14	380
	1000	10 × 20	0.14	680
	2200	12.5 × 25	0.16	1090
	3300	16 × 25	0.18	1400
	4700	16 × 30	0.20	1710
	6800	18 × 35	0.24	2040

WV (Vdc)	Cap (μ F)	Case size Φ D × L(mm)	tan δ	Ripple current (mA rms/105 °C, 120Hz)
35(1V)	4.7	5 × 11	0.12	28
	10	5 × 11	0.12	41
	22	5 × 11	0.12	61
	33	5 × 11	0.12	75
	47	5 × 11	0.12	90
	100	6.3 × 11	0.12	150
	220	8 × 11.5	0.12	270
	330	10 × 12	0.12	350
	470	10 × 16	0.12	460
	1000	12.5 × 20	0.12	810
	2200	16 × 25	0.14	1260
	3300	16 × 35	0.16	1610
	4700	18 × 35	0.18	1910
	50(1H)	0.10	5 × 11	0.10
0.22		5 × 11	0.10	2.9
0.33		5 × 11	0.10	4.3
0.47		5 × 11	0.10	6.2
1.0		5 × 11	0.10	13
2.2		5 × 11	0.10	20
3.3		5 × 11	0.10	25
4.7		5 × 11	0.10	30
10		5 × 11	0.10	40
22		5 × 11	0.10	65
33		6.3 × 11	0.10	90
47		6.3 × 11	0.10	110
100		8 × 11.5	0.10	180
220		10 × 12	0.10	300
330	10 × 16	0.10	410	
470	10 × 20	0.10	530	
1000	12.5 × 25	0.10	950	
2200	16 × 35	0.12	1470	
3300	18 × 35	0.14	1770	
63(1J)	10	5 × 11	0.09	46
	22	5 × 11	0.09	71
	33	6.3 × 11	0.09	100
	47	6.3 × 11	0.09	120
	100	10 × 12	0.09	215
	220	10 × 16	0.09	335
	330	10 × 20	0.09	510
	470	12.5 × 20	0.09	640
	1000	16 × 25	0.09	930
	100(2A)	0.10	5 × 11	0.08
0.22		5 × 11	0.08	3.4
0.33		5 × 11	0.08	5.0
0.47		5 × 11	0.08	7.1
1.0		5 × 11	0.08	15
2.2		5 × 11	0.08	21
3.3		5 × 11	0.08	29
4.7		5 × 11	0.08	32
10		6.3 × 11	0.08	54
22		8 × 11.5	0.08	93
33		8 × 11.5	0.08	130
47		10 × 12	0.08	165
100		10 × 20	0.08	265
220		12.5 × 25	0.08	440

RE Series

● STANDARD RATINGS

WV (Vdc)	Cap (μF)	Case size Φ D × L(mm)	tan δ	Ripple current (mA _{rms} /105℃, 120Hz)
100(2A)	330	16 × 25	0.08	540
	470	16 × 30	0.08	715
	1000	18 × 40	0.08	985
160(2C)	3.3	6.3 × 11	0.20	32
	4.7	6.3 × 11	0.20	38
	10	8 × 12	0.20	65
	10	10 × 12	0.20	76
	22	10 × 12	0.20	98
	22	10 × 16	0.20	108
	22	10 × 20	0.20	120
	33	10 × 16	0.20	158
	33	10 × 20	0.20	165
	47	10 × 20	0.20	182
	47	12.5 × 20	0.20	205
	68	12.5 × 20	0.20	265
	100	12.5 × 25	0.20	318
	100	16 × 25	0.20	335
200(2D)	1	6.3 × 11	0.20	16
	2.2	6.3 × 11	0.20	22
	3.3	6.3 × 11	0.20	32
	4.7	8 × 12	0.20	48
	10	8 × 12	0.20	78
	10	10 × 12	0.20	82
	10	10 × 16	0.20	86
	22	10 × 16	0.20	128
	22	10 × 20	0.20	132
	33	10 × 20	0.20	185
	33	12.5 × 20	0.20	194
	47	12.5 × 20	0.20	225
	68	12.5 × 25	0.20	308
	82	12.5 × 25	0.20	318
100	16 × 25	0.20	345	
150	16 × 25	0.20	446	
180	16 × 30	0.20	560	
220	16 × 35	0.20	678	
220	18 × 30	0.20	695	
330	18 × 35	0.20	755	
470	18 × 45	0.20	938	
250(2E)	2.2	6.3 × 11	0.20	22
	3.3	6.3 × 11	0.20	32
	3.3	8 × 12	0.20	34
	4.7	6.3 × 11	0.20	38
	4.7	8 × 12	0.20	48
	10	10 × 12	0.20	75
	10	10 × 16	0.20	84
	22	10 × 20	0.20	128
	22	12.5 × 20	0.20	145
	33	10 × 20	0.20	150
	33	12.5 × 20	0.20	185
	47	12.5 × 20	0.20	232
	47	12.5 × 25	0.20	245
	100	16 × 25	0.20	370
100	16 × 30	0.20	400	
150	16 × 35	0.20	468	
220	18 × 35	0.20	660	
220	18 × 40	0.20	702	
330	18 × 40	0.20	730	

WV (Vdc)	Cap (μF)	Case size Φ D × L(mm)	tan δ	Ripple current (mA _{rms} /105℃, 120Hz)
350(2V)	0.47	6.3 × 11	0.24	11
	1	6.3 × 11	0.24	16
	2.2	8 × 12	0.24	26
	3.3	8 × 12	0.24	34
	3.3	10 × 12	0.24	38
	4.7	8 × 12	0.24	48
	4.7	10 × 12	0.24	52
	10	10 × 12	0.24	68
	10	10 × 16	0.24	82
	10	10 × 20	0.24	88
	22	12.5 × 20	0.24	154
	33	12.5 × 20	0.24	184
	33	16 × 20	0.24	198
	47	16 × 25	0.24	250
68	16 × 25	0.24	335	
100	18 × 30	0.24	398	
400(2G)	1	6.3 × 11	0.24	16
	2.2	6.3 × 11	0.24	30
	2.2	8 × 12	0.24	34
	3.3	8 × 12	0.24	35
	3.3	10 × 12	0.24	38
	4.7	8 × 12	0.24	48
	4.7	10 × 12	0.24	52
	10	10 × 16	0.24	98
	10	10 × 20	0.24	115
	22	12.5 × 25	0.24	192
	33	16 × 20	0.24	258
	47	16 × 25	0.24	305
	68	16 × 30	0.24	465
	68	18 × 25	0.24	445
82	18 × 25	0.24	474	
100	16 × 40	0.24	544	
100	18 × 30	0.24	532	
120	18 × 35	0.24	588	
150	18 × 40	0.24	668	
450(2W)	0.47	8 × 12	0.24	11
	1	8 × 12	0.24	18
	2.2	8 × 12	0.24	25
	2.2	10 × 12	0.24	32
	3.3	10 × 12	0.24	36
	3.3	10 × 16	0.24	40
	4.7	10 × 20	0.24	55
	10	10 × 20	0.24	90
	10	12.5 × 20	0.24	100
	22	12.5 × 25	0.24	168
	22	16 × 20	0.24	185
	33	16 × 25	0.24	215
	47	16 × 30	0.24	344
	68	18 × 30	0.24	455
82	18 × 30	0.24	472	
100	18 × 35	0.24	530	
120	18 × 40	0.24	582	
150	18 × 50	0.24	700	
500(2H)	6.8	10 × 16	0.24	62
	10	10 × 16	0.24	65
	15	12.5 × 16	0.24	70
	22	12.5 × 20	0.24	100
	33	16 × 20	0.24	128
	47	16 × 25	0.24	160

物料编码原则 Part Number System

1	2	3	4	5	6	7	8	9	10	11	12	13	14	15	16	17
E	R	G	2	D	1	5	0	M	1	0	1	3	0	0	Y	
①	②		③		④			⑤	⑥			⑦		⑧	⑨	
分类	系列		电压		容量			误差	直径		高度		引脚		颜色	其他
Category	Series		Voltage		Capacitance			Tol.	Dia.		Length		Terminal		Colour	Other

①分类Category

编码Code	代码Code	种类Type	备注Remark
1	E	Electrolytic Capacitor	铝电解电容
	P	Conductive Polymer	导电高分子固体铝
	S	super-capacitor	超级电容

②系列Series			③电压Voltage			④容量Capacitance			⑤Tolerance		⑥尺寸Size				⑦引脚Terminal				
系列series	编码Code		电压WV	编码Code		容量Cap	编码Code			容量误差Tolerance	编码Code	直径编码Dia. Code		高度编码Length Code		形式Specification	编码Code		
	2	3		4	5		6	7	8			9	10	11	12			13	14-15
SM	S	M	4	0	G	0.1	R	1	0	-5~+5	J	3	5	0	3	0	5	Bulk packing	00
SS	S	S	6.3	0	J	0.22	R	2	2	-10~+10	K	4	5	0	4	0	5	Φ4-18 Taping	T1
NP	N	P	10	1	A	0.33	R	3	3	-20~+20	M	5	5	0	5	0	5		T2
LL	L	L	16	1	C	0.47	R	4	7	-5~+20	F	6.3	5	0	6	0	5		T3
RD	R	D	25	1	E	1	1	R	0	-10~+20	V	4	7	0	4	0	7		T4
RE	R	E	35	1	V	2.2	2	R	2	-10~+30	Q	5	7	0	5	0	7	Lead Cut	F
RT	R	T	40	1	G	3.3	3	R	3	-20~+0	S	6.3	7	0	6	0	7		C
RF	R	F	50	1	H	4.7	4	R	7	-0~+20	A	8	7	0	8	0	7		R
RG	R	G	55	1	I	6.8	6	R	8			5	11	0	5	1	1		Y
RJ	R	J	63	1	J	10	1	0	0			6.3	11	0	6	1	1		M
RR	R	R	70	1	L	22	2	2	0			8	12	0	8	1	2		X
LF	L	F	80	1	K	33	3	3	0			8	16	0	8	1	6		Z
LJ	L	J	100	2	A	47	4	7	0			10	12	1	0	1	2		K
LR	L	R	120	2	B	100	1	0	1			10	16	1	0	1	6		
LG	L	G	140	2	L	220	2	2	1			8	20	0	8	2	0		
RS	R	S	160	2	C	330	3	3	1			10	20	1	0	2	0		
RN	R	N	180	2	Q	470	4	7	1			13	20	1	3	2	0		
RV	R	V	200	2	D	560	5	6	1			13	25	1	3	2	5		
LH	L	H	220	2	N	1000	1	0	2			16	25	1	6	2	5		
TE	T	E	250	2	E	1500	1	5	2			16	32	1	6	3	2		
TF	T	F	300	2	S	2200	2	2	2			16	36	1	6	3	6		
TG	T	G	315	2	F	3300	3	3	2			18	32	1	8	3	2		
LP	L	P	350	2	V	4700	4	7	2			18	36	1	8	3	6		
LT	L	T	385	2	P	6800	6	8	2			18	40	1	8	4	0		
LS	L	S	400	2	G	10000	1	0	3										
LV	L	V	420	2	T	15000	1	5	3										
			450	2	W	22000	2	2	3										
			500	2	H	33000	3	3	3										
			550	2	J	56000	5	6	3										
			600	2	K	68000	6	8	3										

⑧颜色代码 Colour Code

编码Code	颜色	黑色	黄色	墨绿色	淡绿色	橙色	白色	紫色
16	Colour	Black	Yellow	Ink Green	Light Green	Orange	White	Purple
	代码Code	B	Y	I	L	O	W	P

⑨特殊代码 Other

用于标记客户特殊要求

Used to mark special requirements of customers

焊接温度及注意事项 Solder temperature and notes

●无铅波峰焊 Ware soldering(lead-free)

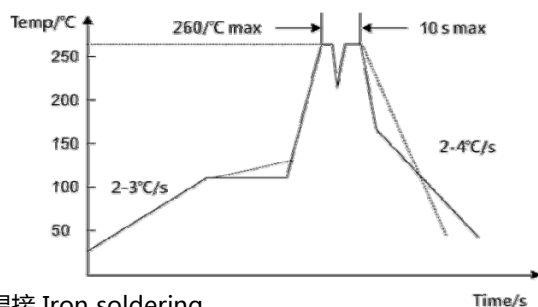

注意事项 notes:

- ①PCB主面预热温度最高升温斜率:2→3°C/sec, 预热时长:120s左右;
- ②PCB主面预热温度范围:90-130°C;
- ③PCB背面最高预热温度不超过130°C;
- ④波峰温度与预热区温度落差不能大于150°C;
- ⑤波峰焊锡炉温度应控制在250-260°C之间;
- ⑥波谷温度最好不能低于217°C, 也就是说如果是双波峰, 两个波峰之间落差不能大于60度, 以防造成二次焊接;
- ⑦焊接时间:双波峰"1"控制在0.5-2s之间, 波峰"11"的时间控制在1.5-4s之间, 合计时间:2-6s. 单波峰时间控制在2-6s.
- ⑧冷却区斜率一般指从最高温降到90°C时间平均负斜率-4→-2°C/s

●烙铁焊接 Iron soldering

烙铁作业:最高温度: 350 ± 5°C, 焊接时间: 3±0.5 秒

Lead Forming

Taping Specifications

Fig.1 Code:T1

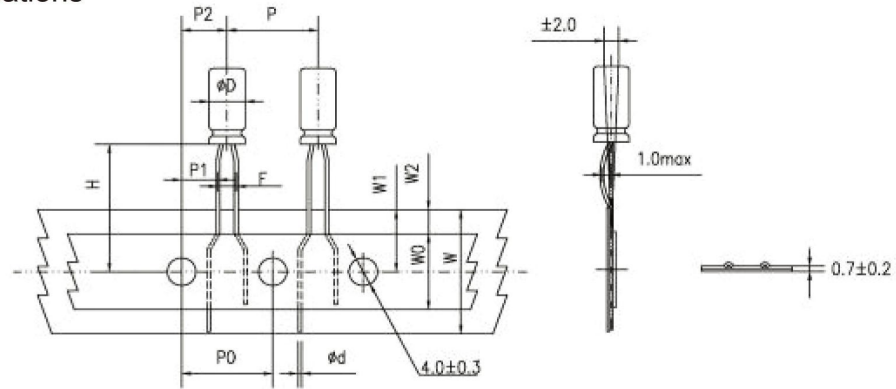

Fig.2 Code:T2

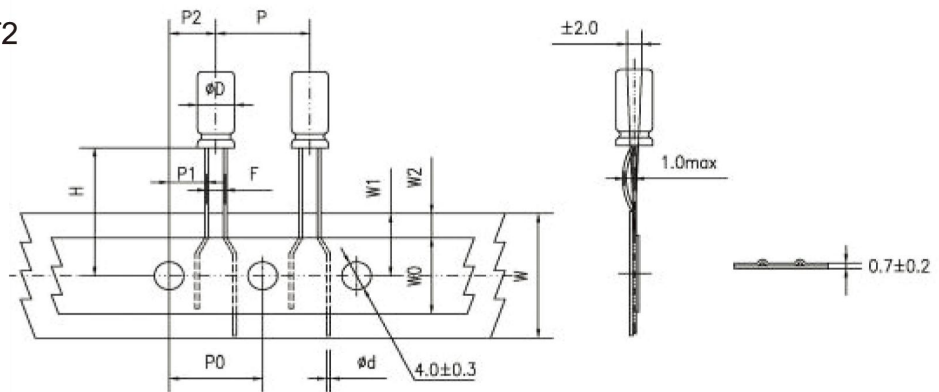

Fig.3 Code:T2

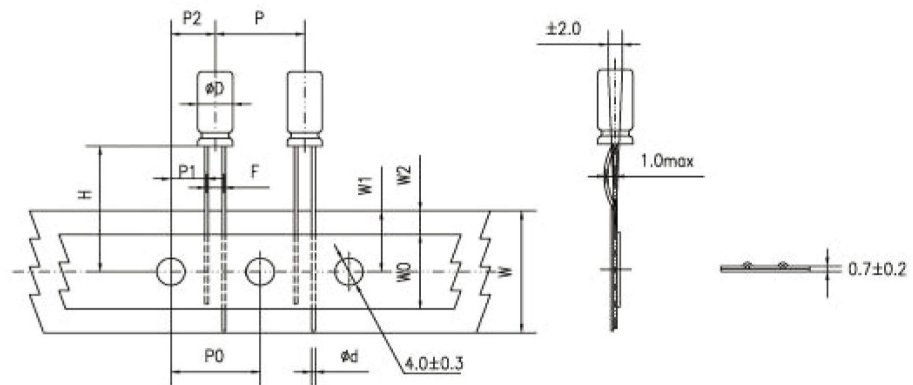
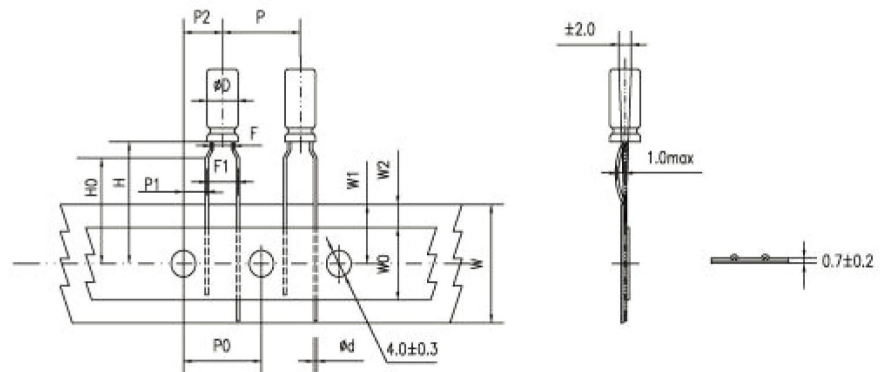

Fig.4 Code:T3



Specification Fig.1 & Fig.2 & Fig.3

Items	Symbol	CASE SIZE											Tolerance		
		4 × 5 4 × 7		5 × 5 5 × 7		5x11		6.3x5	6.3x7 6.3x9	6.3x11 6.3x12	8x5/7 8x9/11 8x11.5 8x12	8x16 8x20		10x9/12 10x12.5 10x13/16 10x20/25	
Pin Code		T ₁	T ₂	T ₁	T ₂	T ₁		T ₂	T ₂	T ₂	T ₂	T ₂	T ₂		
Lead wire diameter	φd	0.45		0.45		0.5		0.45	0.5	0.5	0.5	0.45/0.5	0.6	0.6	± 0.05
Pitch of body	P	12.7		12.7		12.7		12.7	12.7	12.7	12.7	12.7	12.7	12.7	± 1.0
Feed hole pitch	PO	12.7		12.7		12.7		12.7	12.7	12.7	12.7	12.7	12.7	12.7	± 0.2
Hole center to lead distance	P1	5.1	5.6	5.1	5.35	5.1	5.35	5.1	5.1	5.1	4.6	4.6	3.85	± 0.7	
Feed hole center to body center distance	P2	6.35		6.35		6.35		6.35	6.35	6.35	6.35	6.35	6.35	± 1.0	
Lead to lead distance	F	2.5	1.5	2.5	2.0	2.5	2.0	2.5	2.5	2.5	3.5	3.5	5.0	± 0.5	
Height of body from tape center	H	18.5		18.5		18.5		18.5	18.5	18.5	18.5	18.5	18.5	± 0.75	
Base tape width	W	18.0		18.0		18.0		18.0	18.0	18.0	18.0	18.0	18.0	± 0.5	
Adhesive tape width	WO	11.0		11.0		11.0		11.0	11.0	11.0	11.0	11.0	11.0	min	
Hole positron	W1	9.0		9.0		9.0		9.0	9.0	9.0	9.0	9.0	9.0	+0.75 -0.5	
Hole down tape position	W2	3.0		3.0		3.0		3.0	3.0	3.0	3.0	3.0	3.0	max	

Specification Fig.4

Items	Symbol	CASE SIZE									Tolerance
		4 × 5 4 × 7	5 × 5	5 × 7	5 × 11	6.3 × 5	6.3 × 7 6.3 × 9	6.3 × 11 6.3 × 12	8 × 5/7 8 × 9/11 8 × 11.5/12	8 × 16 8 × 20	
Pin Code		T ₃	T ₃	T ₃	T ₃	T ₃	T ₃	T ₃	T ₃	T ₃	
Lead wire diameter	φd	0.45	0.45	0.45	0.5	0.45	0.5	0.5	0.45/0.5	0.6	± 0.05
Pitch of body	P	12.7	12.7	12.7	12.7	12.7	12.7	12.7	12.7	12.7	± 1.0
Feed hole pitch	PO	12.7	12.7	12.7	12.7	12.7	12.7	12.7	12.7	12.7	± 0.2
Hole center to lead distance	P1	3.85	3.85	3.85	3.85	3.85	3.85	3.85	3.85	3.85	± 0.7
Feed hole center to body center distance	P2	6.35	6.35	6.35	6.35	6.35	6.35	6.35	6.35	6.35	± 1.0
Lead to lead distance	F	1.5	2.0	2.0	2.0	2.5	2.5	2.5	3.5	3.5	± 0.5
Lead to lead distance	F1	5.0	5.0	5.0	5.0	5.0	5.0	5.0	5.0	5.0	+0.8 -0.2
Height of body from tape center	H	18.5	18.5	18.5	18.5	18.5	18.5	18.5	18.5	18.5	± 0.75
Lead wire clinch height	HO	16.0	16.0	16.0	16.0	16.0	16.0	16.0	16.0	16.0	± 0.5
Base tape width	W	18.0	18.0	18.0	18.0	18.0	18.0	18.0	18.0	18.0	± 0.5
Adhesive tape width	WO	11.0	11.0	11.0	11.0	11.0	11.0	11.0	11.0	11.0	min
Hole position	W1	9.0	9.0	9.0	9.0	9.0	9.0	9.0	9.0	9.0	+0.75 -0.5
Hole down tape position	W2	3.0	3.0	3.0	3.0	3.0	3.0	3.0	3.0	3.0	max

● Lead Forming & Cut:

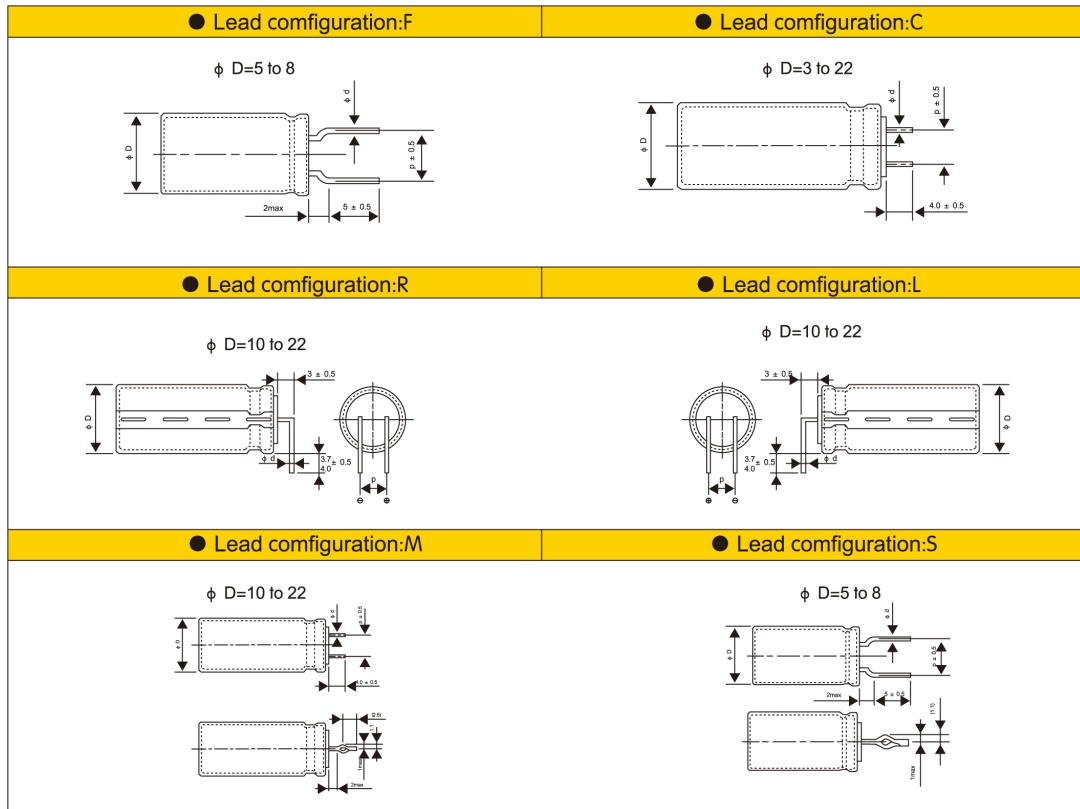

● LEAD SPACING&RECOMMENDED PCB DIMENSIONS

(mm)

Dimension	ϕD	ϕd	p	PC Board		Lead Configuration
				Hole diameter	Thickness	
5	0.5	0.5	5.0	0.8	1.6	F C S
6.3	0.5	0.5	5.0	0.8		
8	0.5/0.6	0.5	5.0	1.0		
10	0.6	0.6	5.0	1.0	1.6	C M R L
12.5	0.6	0.6	5.0	1.0		
16	0.8	0.8	7.5	1.2		
18	0.8	0.8	7.5	1.2		
20	0.8	0.8	7.5	1.2		
22	0.8	0.8	10.0	1.2		

● Lead configuration: B

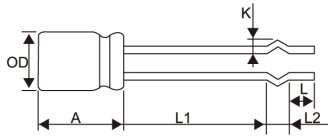

∅D	L1	L2	K	A	L	
5	17.5-19.5	2.6	1.9	10.0-15.0	3.0-5.0	
6.3	17.5-19.5	2.6	1.9	10.0-16.0		
8	12.0-14.0	2.5	1.3	10.0-20.0		
8	13.5-15.5	2.5	1.5			
8	13.0-15.0	3.0	1.5			
8	19.5-21.5	3.0	1.5			
8	21.0-23.0	3.0	1.5			
10	7.5-9.5	2.5	1.7	10.0-25.0		
10	17.0-19.0	2.5	1.7			
10	10.5-12.5	2.5	1.5			
10	10.0-12.0	3.0	1.5			
10	13.0-15.0	3.0	1.5			
10	18.0-20.0	3.0	1.5			
10	21.0-23.0	3.0	1.5			
	± 1.0	± 0.5	0.3	± 1.0		± 1.0

● Lead configuration: K

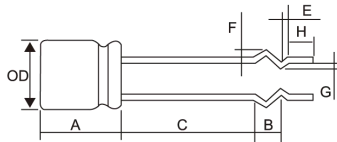

∅D	C	B	E	F	G	A	H
8	13.5-15.5	3	1.2	1.8	0.8	10-20	3.0-5.0
10	18.5-20.5	3	1.2	1.8	1	10-25	
10	19.0-21.0	3	1.5	1.4	0.5		
	± 1.0	± 0.5	± 0.3	± 0.3	± 0.3	± 1.0	± 1.0

■ 概述 Scope

本规范规定了所有系列径向引线引出铝电解电容器的技术规范。

This specification covers "ALL series" miniature single-ended aluminium electrolytic capacitors.

■ 参考标准 Standard

本承认书参考 JIS-C-5101-1 和 JIS-C-5101-4 制定

This approval sheet consulted the institute of JIS-C-5101-1 and JIS-C-5101-4.

■ 工作温度范围 Operating temperature range

工作温度范围是电容器在施加额定工作电压条件下，可以长期可靠工作的环境温度范围。

Operating temperature range is the range of ambient temperature at which the capacitor can be operated continuously at rated

■ 测试环境 Condition of test

如果没有其他规定，标准的测试、检验环境条件如下所示：

环境温度：15℃~35℃

相对湿度：25%~75%

大气压力：86kPa~106kPa

如果对测试结果有异议，可以在以下条件测试：

环境温度：20±1℃

相对湿度：60%~67%

大气压力：86kPa~106kPa

Unless otherwise specified, the standard range of atmospheric conditions for making measurements and tests are as follows:

Ambient temperature : 15°C to 35°C

Relative humidity : 25% to 75% A

ir pressure: 86kPa to 106kPa

If there may be doubt on the results, measurements shall be made within the following limits:

Ambient temperature : 20±1°C

Relative humidity: 60% to 67%

Air pressure : 86kPa to 106kPa

■ 试验方法及要求 Tests

项目 Item	试验条件 Test Conditions	性能要求 Performance	
浪涌电压 Surge Voltage	温度 15~35℃，施加额定浪涌电压，充电 30 秒，放电 5 分 30 秒，共循环 1000 次。 At 15~35℃, applying Surge Voltage 1000 cycles of 30s on and 330s off.	无可见损伤 No visible damage	
		ΔC/C	≤± 10 %
		tgδ	≤初始规定值 Not more than specified value
		I	≤初始规定值 Not more than specified value
耐久性 Load Life	额定温度下,施加额定电压(直流电压值+交流电压峰值≤标称电压)规格时间,恢复 16 小时后: After applying rated voltage (Voltage+peak ripple voltage ≤Rated voltage)specified times at rated temperature and then resumed 16 hours.	± 20 %初始测量值以内 Within ± 20 % of initial value	
		ΔC/C	± 20 %初始测量值以内 Within ± 20 % of initial value
		tgδ	≤200%初始规定值 Not more than 200% of specified value
		I	≤初始规定值 Not more than specified value
贮存 Shelf Life	105℃, 1000 小时。试验后: 恢复24小时 施加额定电压 30 分钟后 1000 hours at +105℃.After test:UR to be applied for 30min >24h before measurement.	± 20 %初始测量值以内 Within ± 20 % of initial value	
		ΔC/C	± 20 %初始测量值以内 Within ± 20 % of initial value
		tgδ	≤200%初始规定值 Not more than 200% of specified value
		I	≤200%初始规定值 Not more than 200% of specified value
可焊性 Solderability	焊料槽温度为 235±5℃, 浸渍深度占整个引出线的 90%, 浸渍持续时间为 2 秒。 Tank temperature : 235±5℃; Impregnating depth:≥90% of the total lead wire; Impregnating depth:2s.	引出端的镀层良好, 焊料自由流动, 引出端湿润。 浸渍面积 90%以上附着焊锡 The lead wire is coated by tin and wet. At least 90% of Circumferential surface of the dipped portion of termination shall be covered with new solder	
耐焊接热 Resistance to soldering heat	方法: 焊料槽温度为260±5℃, 浸渍深度 6mm 浸渍持续时间为 10 秒。 Tank temperature:260±5℃; Impregnating depth:6mm; Impregnating time:10s.	无可见损伤 No visible damage	
		ΔC/C	≤± 10 %
		tgδ	≤初始规定值 Not more than specified value
		I	≤初始规定值 Not more than specified value
稳态湿热 Stable Humidity	试验温度:+40℃,湿度:90~95%,不施加电压21天 21 days at 40℃,RH 90 to 95%, no voltage applied.	无可见损伤和电解液漏出, 且标志清晰 No visible damage; no leakage of electrolyte; marking legible	
		ΔC/C	≤± 5 %
		tgδ	≤初始规定值 Not more than specified value
		I	≤初始规定值 Not more than specified value
耐振性 Resistance to vibration	频率: 10-55-10 Hz/分 Frequency :From 10 to 55 Hz and return to 10 Hz,shall be transferred in 1 Min Total Amplitude: 1.5 mm 条件: X. Y. Z 方向各2小时 Direction and duration of vibration :3 orthogonal directions mutually each for 2 hours Total 6 hours.	无可见损伤和电解液漏出, 且标志清晰 No visible damage; no leakage of electrolyte; marking legible	
		ΔC/C	≤± 5 %

■ 试验方法及要求 Tests

项目 Item	试验条件 Test Conditions	性能要求 Performance																								
高低温特性 Characteristic at High and low temperature	<p>电容器根据下表的次序处理 The capacitor shall be subjected in turn to the procedures specified below.</p> <table border="1"> <thead> <tr> <th>阶段 Step</th> <th>温度 Temperater</th> <th>时间 Time</th> </tr> </thead> <tbody> <tr> <td>1</td> <td>20±2℃</td> <td>热平衡状态 thermal stability</td> </tr> <tr> <td>2</td> <td>-40℃</td> <td>*2 hours</td> </tr> <tr> <td>3</td> <td>20±2℃</td> <td>热平衡状态 thermal stability</td> </tr> <tr> <td>4</td> <td>105℃</td> <td>*2 hours</td> </tr> <tr> <td>5</td> <td>20±2℃</td> <td>热平衡状态 thermal stability</td> </tr> </tbody> </table> <p>*电容器放置在每一温度下，待阻抗或电容量稳定后方可测试 *The capacitor should be stored at each temperature until measured impedance are stabilized. 阶段 1: 测定阻抗值 Step 1: Measured impedance. 阶段 2: 放置 2 小时后，达到热平衡状态再测。 Step 2 : After the capacitor being stored for 2 hours, impedance shall be Measured. The measurement shall be made at thermal stability. 阶段 4: 放置 2 小时后，达到热平衡状态再测 Step 4 : After the capacitor being stored for 2 hours, Leakage Current shall be Measured. The measurement shall be made at thermal stability.</p>	阶段 Step	温度 Temperater	时间 Time	1	20±2℃	热平衡状态 thermal stability	2	-40℃	*2 hours	3	20±2℃	热平衡状态 thermal stability	4	105℃	*2 hours	5	20±2℃	热平衡状态 thermal stability	<table border="1"> <tbody> <tr> <td>阶段 2 Step 2</td> <td>阻抗比(对阶段 1) Impedance ratio</td> <td>≤5</td> </tr> <tr> <td>阶段 4 Step 4</td> <td>漏电流 Leakage Current</td> <td>≤10 倍规定值 Not more than 1000% of specified value</td> </tr> </tbody> </table>	阶段 2 Step 2	阻抗比(对阶段 1) Impedance ratio	≤5	阶段 4 Step 4	漏电流 Leakage Current	≤10 倍规定值 Not more than 1000% of specified value
阶段 Step	温度 Temperater	时间 Time																								
1	20±2℃	热平衡状态 thermal stability																								
2	-40℃	*2 hours																								
3	20±2℃	热平衡状态 thermal stability																								
4	105℃	*2 hours																								
5	20±2℃	热平衡状态 thermal stability																								
阶段 2 Step 2	阻抗比(对阶段 1) Impedance ratio	≤5																								
阶段 4 Step 4	漏电流 Leakage Current	≤10 倍规定值 Not more than 1000% of specified value																								
耐溶剂性 Resisting Solvent	溶剂: 异丙醇 Solvent :Isopropylalcohol 温度: 20-25℃ 时间 : 30±5s Temperature: 20-25℃ Time : 30±5s	外观: 无显著异常 Appearance :No remarkable abnormality																								

■ 试验方法及要求 Tests

项目 Item	试验条件 Test Conditions	性能要求 Performance																								
端子强度 Terminal Strength	<p>抗拉强度: 沿电容器端子引线方向施加拉力(如下表), 10±1 秒</p> <table border="1"> <tr> <td>引线直径Φ</td> <td>0.45</td> <td>0.5</td> <td>0.6</td> <td>0.8</td> <td>1</td> </tr> <tr> <td>拉力N</td> <td colspan="2">5</td> <td colspan="2">10</td> <td>20</td> </tr> </table> <p>Tensile strength of terminal: A static load(stated in the table above)shall be applied to the terminal in the axial direction and acting in a direction away from the body for 10±1 sec..</p> <p>端子抗弯强度: 在电容器引线施加固定重力(如下表), 然后将电容体弯折 90°后回到原位, 再向相反方向弯折 90°后回到原位。上述过程在 5 秒内完成。</p> <table border="1"> <tr> <td>引线直径Φ</td> <td>0.45</td> <td>0.5</td> <td>0.6</td> <td>0.8</td> <td>1</td> </tr> <tr> <td>拉力N</td> <td colspan="2">2.5</td> <td colspan="2">5</td> <td>10</td> </tr> </table> <p>Bending strength of terminal: Hang the specified dead weight(stated in the table above),then bend the body through 90°, return to the original position. Next bend it in opposite direction through 90° with the same speed,again return to the original position. Complete this operation in about 5 sec.</p>	引线直径Φ	0.45	0.5	0.6	0.8	1	拉力N	5		10		20	引线直径Φ	0.45	0.5	0.6	0.8	1	拉力N	2.5		5		10	<p>测定静电容量时, 无接触不良, 开路和短路现象, 另外无机械损伤和端子损伤。 When the capacitance is measured ,there shall be no intermittent contacts or open –or short –ciruiting . There shall be no such mechanical damage etc. as terminal damage</p>
引线直径Φ	0.45	0.5	0.6	0.8	1																					
拉力N	5		10		20																					
引线直径Φ	0.45	0.5	0.6	0.8	1																					
拉力N	2.5		5		10																					
压力释放 Pressure relief	<p>直流试验 D.C. test 施加同额定电压相等的反电压。 Reversed polarity D.C. rated voltage shall be applied to the capacitor.</p> <p>注: 1. 试验开始 30 Min 后,防爆装置不动作时,停止试验。 2. 该规定适用于铝壳直径6.3mm 以上的电容器。 Note: 1. When the pressure relief device does not open even 30 min after commencement of this test, the test may be ended. 2. This requirement applies to capacitors with a diameter of 6.3mm or more</p>	<p>防爆装置释放时, 无燃烧、无爆炸或铝壳和封口材料的分离。 The pressure relief device shall open in such a way as to avoid any danger of fire or explosion of Capacitor elements .</p>																								

提示: Notes:

*温度系数不应用在寿命计算公式中,只能作为参考

Temperature coefficient is not used in life formula but for reference.

*每升高5℃,纹波电流产生的温升使电容器的使用寿命减半,从而降低电容器的使用寿命.当实际使用中需延长寿命性能时,必须降低rms纹波电流。

The endurance of capacitors is reduced with internal heating produced by ripple current at the rate of halving the lifetime with every 5°C rise.

When long life performance is required in actual use, the rms ripple current has to be reduced.

■铝电解电容器的使用注意事项 Guidelines For Using Aluminum Electrolytic Capacitor

为使您获得电解电容器的最佳性能和延长电解电容器的使用寿命，在使用电解电容器前，请务必阅读本注意事项。

Upon using Aluminum Electrolytic Capacitors, please proper handing and observing to following important points will insure optimum capacitor performance and long life.

①直流电解电容器是有极性的.DC electrolytic capacitors are polarized.

确定极性，极性标志在电容器的基体上。以免因极性反可能引起电路短路或电容器损坏，当极性不固定或不确定的，使用 双极性电容器。

注意直流电解电容器不能用于交流。

Make sure of the polarity .The polarity is marked on the body of the capacitor .Application of the reversed voltage cause a short circuit or damage to the capacitor .

Use bipolar capacitors when the polarity is not determined or unknown . Note that DC electrolytic capacitors can not be used for AC application .

②使用电压不要大于额定电压.Do not apply voltage greater than rated voltage .

使用电压大于额定电压，漏电流会增大，可能损坏电容器。建议工作电压为额定电压的70~80%，电容器在建议的工作电压下使用可延长电容器的寿命。

IF a voltage exceeding the rated voltage is applied ,the leakage current will increase , which damage the capacitor . Recommended working voltage is 70 to 80 percent of tatted voltage . Using capacitors at recommended working voltage prolongs capacitor life .

③不要使过大的纹波电流通过电容器.Do not allow excessive ripple current through the capacitor .

流过电容器的纹波电流超过许可值，将会引起电容器发热，电容量减少，损害电容器。通过电容器的纹波电流不要大于允许值。

The flow of ripple current over permissible ripple current will cause heat of the capacitor ,which may decrease the capacitance and damage the capacitor .

ripple current on the capacitor must be at or bellow allowable level .

④快速的充放电电路中,使用专门设计的电容器.Use specially designed capacitors for the circuits where charge and discharge are frequency repeated .

在经受快速的周期性充放电电路中，电容器可能受损害，它的寿命因容量下降、温升等原因而缩短，在这种电路中，一定要使用专门设计的电容器。

In the circuit subjected to rapid charge cycles ,capacitors may be damaged ,its life may be shortened by capacitance decrease ,heat rise , ect .

Be sure and use special capacitors in these applications .

⑤工作温度范围.Operating temperature range .

电容器的特性随工作温度而变化，在温度较高的情况下，容量、漏电流增大， $tg\delta$ 减少；在低温情况下，容量和漏电流下降， $tg\delta$ 增大。

电容器在较低的温度下使用会确保延长寿命。

The characteristics of capacitors change with the operating temperature .The capacitance and leakage current increase and decrease at higher temperatures .

The capacitance and leakage current decrease and $tg\delta$ increase lower temperature .Usage at lower temperature will ensure longer life .

⑥核对工作频率.Check operating frequency .

电解电容器的容量通常是在 100Hz 或 120Hz 下测得的。然而要记住容量随频率的升高而下降， $tg\delta$ 随频率的升高而增大，并使周围温度升高。

The capacitance of electrolytic capacitors is usually measured at 100Hz or 120Hz . However , remember that capacitance decrease and $tg\delta$ increase as the applied frequency becomes higher whereas the ambient temperature becomes higher .

⑦长时间存放的电容器，在使用前加额定直流电压处理. Apply rated DC voltage treatment to the capacitors which have been stored for a long time

长时间的存放，实际对电容器的容量和 $tg\delta$ 没有多大的影响，然而往往会使漏电流增大，耐压降低。长时间存放后的电容器处理，首先逐渐施加直流电压至额定电压，然后再使用。

Long periods of storage have virtually no effect no a capacitor's capacitance and $tg\delta$.Such periods tend however ,to increase leakage current and decrease withstand voltage .After removing capacitors from long-duration storage ,first apply a gradually increasing DC voltage to rated voltage and then use them.

⑧电容器外壳与阴极端是不绝缘的.The capacitor case is not insulated from the cathode terminal .

电容器外壳与阴极端是通过电解液连接的，如果电容器的外壳必须与线路绝缘，则电容器的安装位置处，一定要采取绝缘出措施。

The capacitor's case and cathode terminal connect through the electrolyte.If the case is to be completely insulated,that insulation must be at the capacitor's mounting point.

⑨电容器的端子或引线上不要施加过大的力.Do not apply excessive force to the terminals and leads.

过大的力施加到端子和引线上，可能引起引线的断裂或端子分裂，转而会引起内部连接的破坏。

The excessive strong force applied to the terminals and lead wires may cause leads to break or terminals to separate and ,in turn ,cause the internal contact to fail.

⑩关于焊接以后的清洗. Cleaning after soldering

① 电容器不能用卤化有机物系列的清洗剂进行清洗。如果必须进行清洗，请使用能够保证电容器质量的清洗剂。

The aluminum electrolytic capacitors should be free of halogenated solvents during board cleaning after soldering. Use solvent proof capacitors when halogenated solvents are used.

② 请不要让固定剂及镀层（涂层剂）将电容器封口部位（端子一侧）全部封住。

Do not cover up all the sealing area of capacitors with adhesives、fixative or coating materials (coating agent), make coverage only partial.

X-ON Electronics

Largest Supplier of Electrical and Electronic Components

Click to view similar products for [Aluminium Electrolytic Capacitors - Radial Leaded](#) category:

Click to view products by [TOPAZ](#) manufacturer:

Other Similar products are found below :

[LXY50VB4.7M-5X11](#) [RFO-100V471MJ7P#](#) [ECE-A1EGE220](#) [B41041A7226M8](#) [B41044A7157M6](#) [NCD681K10KVY5PF](#)

[NEV1000M25EF-BULK](#) [NEV100M35DC](#) [NEV100M63DE](#) [NEV220M25DD-BULK](#) [NEV.33M100AA](#) [NEV4700M50HB](#) [NEV.47M100AA](#)

[NEVH1.0M250AB](#) [NEVH3.3M250BB](#) [NEVH3.3M450CC](#) [KME50VB100M-8X11.5](#) [SG220M1CSA-0407](#) [ES5107M016AE1DA](#)

[ESMG160ETD102MJ16S](#) [ESX472M16B](#) [227RZS050M](#) [476CKH100MSA](#) [477RZS050M](#) [B41793A9108Q1](#) [UVX1V101KPA1FA](#)

[UVX1V222MHA1CA](#) [KME25VB100M-6.3X11](#) [VTL100S10](#) [VTL470S10](#) [VTL470S16A](#) [511D336M250EK5D](#) [052687X](#) [ECE-A1CF471](#)

[NRE-S560M16V6.3X7TBSTF](#) [RGA221M1CTA-0611G](#) [ERZA630VHN182UP54N](#) [UPL1A331MPH](#) [NEV1000M6.3DE](#) [NEV100M16CB](#)

[NEV100M50DD-BULK](#) [NEV2200M16FF](#) [NEV220M50EE](#) [NEV2.2M50AA](#) [NEV330M63EF](#) [NEV4700M35HI](#) [NEV4.7M100BA](#)

[NEV47M16BA](#) [NEV47M50CB-BULK](#) [NEVH1.0M350AB](#)