

Built-in Inrush Current Protection, 300mA High Speed LDO Voltage Regulator

■ GENERAL DESCRIPTION

The XC6223 series is a high speed LDO regulator that features high accurate, low noise, high ripple rejection, low dropout and low power consumption. The series consists of a voltage reference, an error amplifier, a driver transistor, a current limiter, a phase compensation circuit, a thermal shutdown circuit and an inrush current protection circuit.

The CE function enables the circuit to be in stand-by mode by inputting low level signal. In the stand-by mode, the series enables the electric charge at the output capacitor C_L to be discharged via the internal switch, and as a result the V_{OUT} pin quickly returns to the V_{SS} level. The output stabilization capacitor C_L is also compatible with low ESR ceramic capacitors.

The output voltage is selectable in 0.05V increments within the range of 1.2V to 4.0V which fixed by laser trimming technologies. The over current protection circuit and the thermal shutdown circuit are built-in. These two protection circuits will operate when the output current reaches current limit level or the junction temperature reaches temperature limit level.

■ APPLICATIONS

- Digital still cameras
- Smart phones / Mobile phones
- Portable game consoles
- Modules (wireless, cameras, etc.)
- IC recorders
- Mobile devices / terminals
- Bluetooth
- Wireless LAN
- Digital TV tuners

■ FEATURES

Maximum Output Current	: 300mA
Input Voltage Range	: 1.6V ~ 5.5V
Output Voltages	: 2.0V ~ 4.0V (Accuracy $\pm 1\%$) 1.2 ~ 1.95V (Accuracy $\pm 20mV$) 0.05V increments
Dropout Voltage	: 200mV@ $I_{OUT}=300mA$ ($V_{OUT}=3.0V$)
Low Power Consumption	: 100 μA
Stand-by Current	: 0.01 μA
High Ripple Rejection	: 80dB@f=1kHz
Protection Circuits	: Current Limit (400mA) Short Circuit Protection Over Heat Protection Inrush Current Protection
Low ESR Capacitors	: $C_{IN} = 1.0\mu F$, $C_L = 1.0\mu F$
CE Function	: Active High C_L High Speed Discharge
Operating Ambient Temperature	: -40°C ~ 105°C
Packages	: USPQ-4B03 USP-4 SSOT-24 SOT-25 SOT-89-5
Environmentally Friendly	: EU RoHS Compliant, Pb Free

■ TYPICAL APPLICATION CIRCUIT

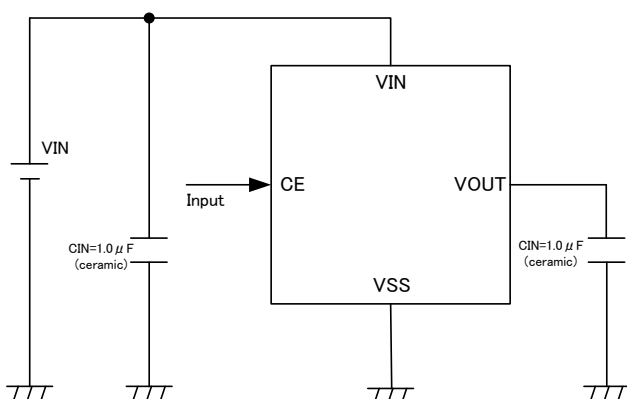

■ TYPICAL PERFORMANCE CHARACTERISTICS

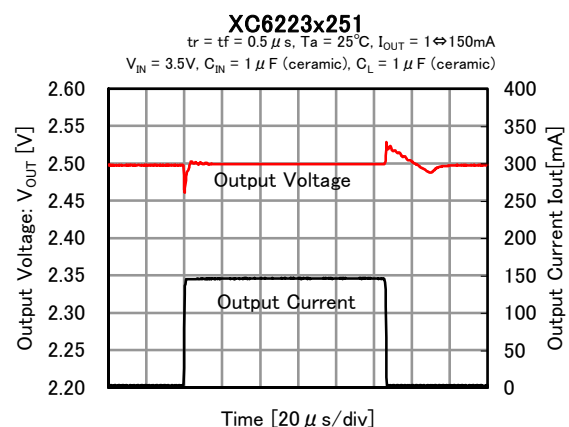

■ BLOCK DIAGRAMS

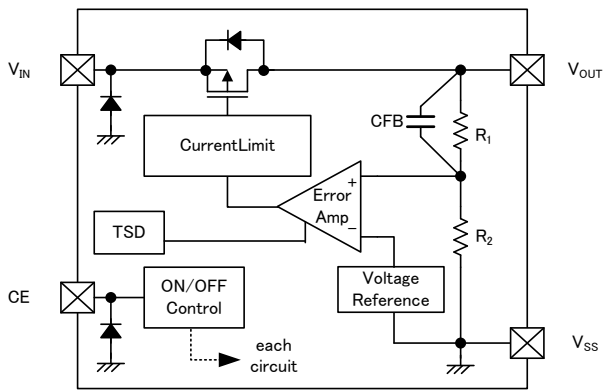

XC6223A/J

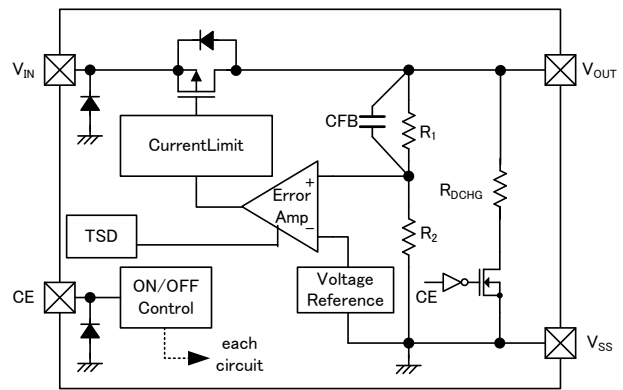

XC6223B/K

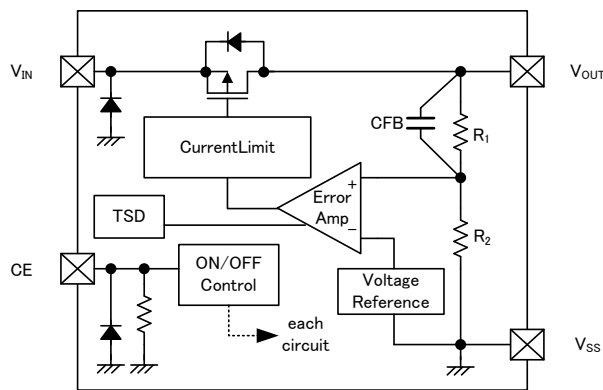

XC6223C/M

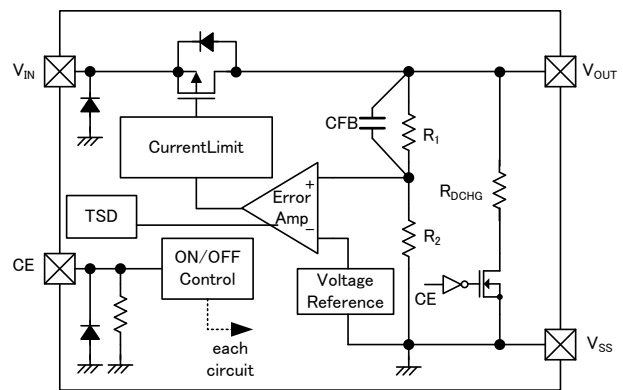

XC6223D/N

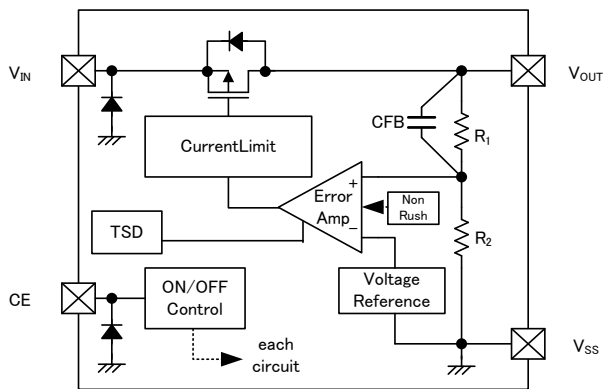

XC6223E/P

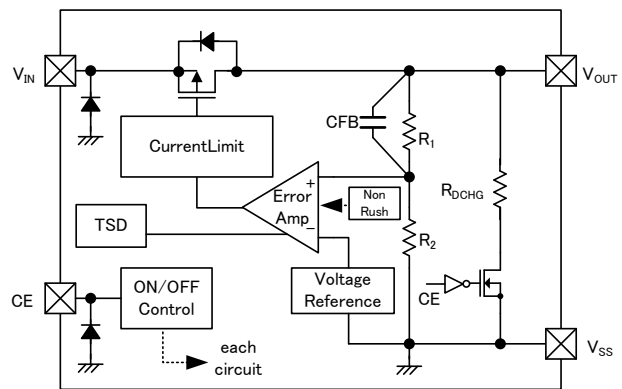

XC6223F/Q

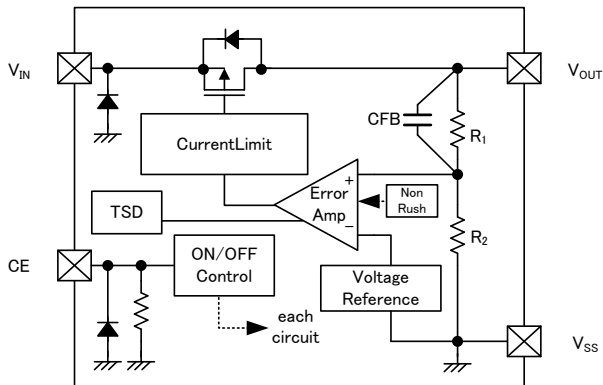

XC6223G/R

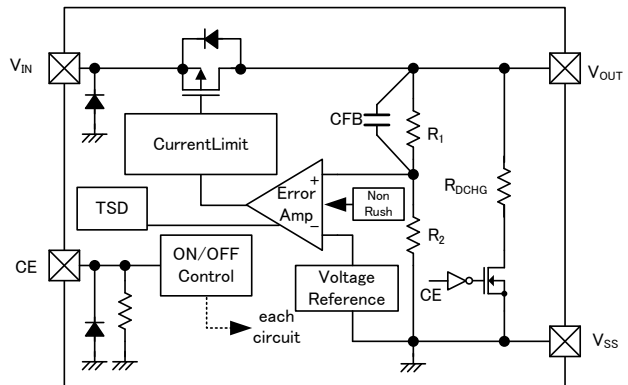

XC6223H/T

* Diodes inside the circuits are ESD protection diodes and parasitic diodes

■ PRODUCT CLASSIFICATION

● Ordering Information

XC6223①②③④⑤⑥-⑦^(*)

DESIGNATOR	ITEM	SYMBOL	DESCRIPTION
①	Type of Regulator	A/J ^(*)	Without Inrush Current Protection, Without CE Pull-down, Without C _L discharge (Semi-Custom)
		B/K ^(*)	Without Inrush Current Protection, Without CE Pull-down, With C _L discharge (Semi-Custom)
		C/M ^(*)	Without Inrush Current Protection, With CE Pull-down ^(*) , Without C _L discharge (Semi-Custom)
		D/N ^(*)	Without Inrush Current Protection, With CE Pull-down ^(*) , With C _L discharge
		E/P ^(*)	With Inrush Current Protection, Without CE Pull-down, Without CL discharge (Semi-Custom)
		F/Q ^(*)	With Inrush Current Protection, Without CE Pull-down, With C _L discharge (Semi-Custom)
		G/R ^(*)	With Inrush Current Protection, With CE Pull-down ^(*) , Without C _L discharge (Semi-Custom)
		H/T ^(*)	With Inrush Current Protection, With CE Pull-down ^(*) , With C _L discharge
②③	Output Voltage	12 ~ 40	ex.) 2.80V → ②=2, ③=8, ④=please see down below.
④	Output Accuracy	1	±1% (V _{OUT} ≥ 2.0V) ±0.02V (V _{OUT} < 2.0V) In case of 2nd decimal place 0 (ex.2.80V → ④=1)
		B	±1% (V _{OUT} ≥ 2.0V) ±0.02V (V _{OUT} < 2.0V) In case of 2nd decimal place 5 (ex.2.85V → ④=B)
⑤⑥-⑦ ^(*)	Packages (Order Unit)	9R-G	USPQ-4B03 (5,000pcs/Reel)
		GR-G	USP-4 (3,000pcs/Reel)
		NR-G	SSOT-24 (3000pcs/Reel)
		MR-G	SOT-25 (3,000pcs/Reel)
		PR-G	SOT-89-5 (1,000pcs/Reel)

^(*) The "-G" suffix denotes Halogen and Antimony free as well as being fully EU RoHS compliant.

⁽²⁾ With CE pin pull-down resistor.

⁽³⁾ Product types A/B/C/D/E/F/G/H are for pre-existing customers who were or are already using these types of products.

For customers who intend to adopt this product newly, please select from types J/K/M/N/P/Q/R/T which have been extended the operating temperature range (105°C compliance).

■ PIN CONFIGURATION

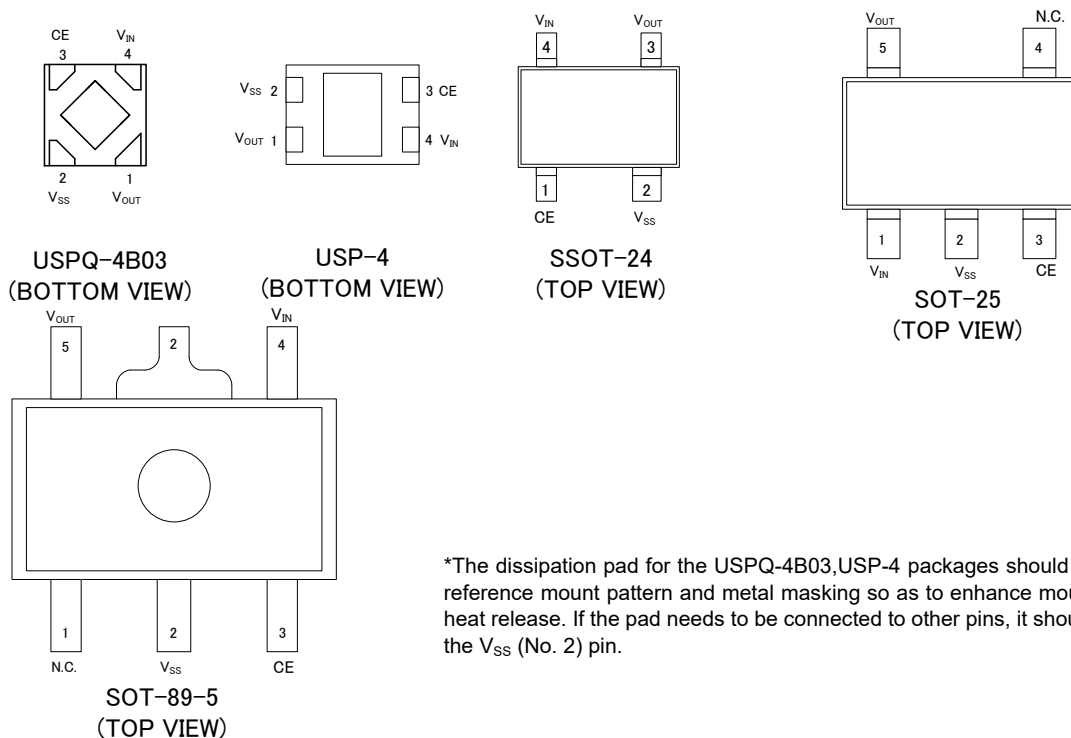

*The dissipation pad for the USPQ-4B03, USP-4 packages should be solder-plated in reference mount pattern and metal masking so as to enhance mounting strength and heat release. If the pad needs to be connected to other pins, it should be connected to the V_{SS} (No. 2) pin.

PIN ASSIGNMENT

PIN NUMBER					PIN NAME	FUNCTIONS
USPQ-4B03	USP-4	SSOT-24	SOT-25	SOT-89-5		
4	4	4	1	4	V _{IN}	Power Input
1	1	3	5	5	V _{OUT}	Output
2	2	2	2	2	V _{SS}	Ground
3	3	1	3	3	CE	ON/OFF Control
-	-	-	4	1	NC	No Connection

LOGIC CONDITION FOR THE PIN

PIN NAME	DESIGNATOR	CONDITION
CE	L	$0V \leq V_{CE} \leq 0.3V$
	H	$1.0V \leq V_{CE} \leq 5.5V$
	OPEN	CE=OPEN

PIN FUNCTION ASSIGNMENT

CE LOGIC CONDITION	IC OPERATION
H	Operation ON
L	Operation OFF(Stand-by)
OPEN	*

* Undefined state in A/B/E/F/J/K/P/Q. On the other hand, Operation OFF states in C/D/G/H/M/N/R/T because that an internal pull-down resistor maintains the CE pin voltage to be low.

■ ABSOLUTE MAXIMUM RATINGS

● A/B/C/D/E/F/G/H Type

PARAMETER		SYMBOL	RATINGS	UNITS
Input Voltage		V_{IN}	$V_{SS} - 0.3 \sim 7.0$	V
Output Voltage		V_{OUT}	$V_{SS} - 0.3 \sim V_{IN} + 0.3$	V
CE Input Voltage		V_{CE}	$V_{SS} - 0.3 \sim 7.0$	V
Power Dissipation ($T_a=25^\circ\text{C}$)	USPQ-4B03	Pd	100 (IC only)	mW
			550 (40mm x 40mm Standard board) ^(*)	
	USP-4		120 (IC only)	
	SSOT-24		1000 (40mm x 40mm Standard board) ^(*)	
			150 (IC only)	
	SOT-25		500 (40mm x 40mm Standard board) ^(*)	
			680 (JESD51-7 board) ^(*)	
	SOT-89-5		250 (IC only)	
			600 (40mm x 40mm Standard board) ^(*)	
			760 (JESD51-7 board) ^(*)	
500 (IC only)				
Operating Ambient Temperature		T_{opr}	-40 ~ 85	°C
Storage Temperature		T_{stg}	-55 ~ 125	°C

^(*) The power dissipation figure shown is PCB mounted and is for reference only.
Please refer to PACKAGING INFORMATION for the mounting condition.

● J/K/M/N/P/Q/R/T Type

PARAMETER		SYMBOL	RATINGS	UNITS
Input Voltage		V_{IN}	$V_{SS} - 0.3 \sim 7.0$	V
Output Voltage		V_{OUT}	$V_{SS} - 0.3 \sim V_{IN} + 0.3$	V
CE Input Voltage		V_{CE}	$V_{SS} - 0.3 \sim 7.0$	V
Power Dissipation ($T_a=25^\circ\text{C}$)	USPQ-4B03	Pd	100 (IC only)	mW
			550 (40mm x 40mm Standard board) ^(*)	
	USP-4		120 (IC only)	
	SSOT-24		1000 (40mm x 40mm Standard board) ^(*)	
			150 (IC only)	
	SOT-25		500 (40mm x 40mm Standard board) ^(*)	
			680 (JESD51-7 board) ^(*)	
	SOT-89-5		250 (IC only)	
			600 (40mm x 40mm Standard board) ^(*)	
			760 (JESD51-7 board) ^(*)	
500 (IC only)				
Operating Ambient Temperature		T_{opr}	-40 ~ 105	°C
Storage Temperature		T_{stg}	-55 ~ 125	°C

^(*) The power dissipation figure shown is PCB mounted and is for reference only.
Please refer to PACKAGING INFORMATION for the mounting condition.

ELECTRICAL CHARACTERISTICS

Ta=25°C

PARAMETER	SYMBOL	CONDITIONS	MIN.	TYP.	MAX.	UNITS	CIRCUITS
Output Voltage	V _{OUT(E)} (*1)	V _{OUT(T)} ≥ 2.0V, V _{CE} =V _{IN} , I _{OUT} =10mA	V _{OUT(T)} × 0.99 (*2)	V _{OUT(T)} (*2)	V _{OUT(T)} × 1.01 (*2)	V	①
		V _{OUT(T)} < 2.0V, V _{CE} =V _{IN} , I _{OUT} = 10mA(*3)	V _{OUT(T)} - 20mV (*2)	V _{OUT(T)} (*2)	V _{OUT(T)} + 20mV (*2)	V	
Maximum Output Current	I _{OUTMAX}	V _{CE} =V _{IN}	300	-	-	mA	①
Load Regulation	ΔV _{OUT}	V _{CE} =V _{IN} , 0.1mA ≤ I _{OUT} ≤ 300mA	-	25	45	mV	①
Dropout Voltage	V _{dif} (*4)	V _{CE} =V _{IN} , I _{OUT} =300mA	E-1			mV	①
Supply Current	I _{SS}	V _{CE} =V _{IN}	-	100	220	μA	②
Stand-by Current	I _{STB}	V _{CE} =V _{SS}	-	0.01	0.4	μA	②
Line Regulation	ΔV _{OUT} / (ΔV _{IN} × V _{OUT})	V _{OUT(T)} +0.5V ≤ V _{IN} ≤ 5.5V V _{CE} =V _{IN} , I _{OUT} =50mA	-	0.01	0.1	%/V	①
Input Voltage	V _{IN}	-	1.6	-	5.5	V	①
Output Voltage Temperature Characteristics (A/B/C/D/E/F/G/H Type)	ΔV _{OUT} / (ΔTa × V _{OUT})	V _{CE} =V _{IN} , I _{OUT} =10mA -40°C ≤ Ta ≤ 85°C	-	±100	-	ppm / °C	①
Output Voltage Temperature Characteristics (J/K/M/N/P/Q/R/T Type)	ΔV _{OUT} / (ΔTa × V _{OUT})	V _{CE} =V _{IN} , I _{OUT} =10mA -40°C ≤ Ta ≤ 105°C	-	±100	-	ppm / °C	①
Power Supply Rejection Ratio	PSRR	V _{OUT(T)} < 2.5V V _{IN} =3.0V _{DC} +0.5V _{p-pAC} V _{CE} =V _{OUT(T)} +1.0V I _{OUT} =30mA, f=1kHz V _{OUT(T)} ≥ 2.5V V _{IN} ={V _{OUT(T)} +1.0}V _{DC} +0.5V _{p-pAC} V _{CE} =V _{OUT(T)} +1.0V I _{OUT} =30mA, f=1kHz	-	80	-	dB	③
Current Limit	I _{LIM}	V _{CE} =V _{IN}	310	400	-	mA	①
Short Current	I _{SHORT}	V _{CE} =V _{IN} , V _{OUT} =V _{SS}	-	50	-	mA	①
CE High Level Voltage	V _{CEH}	-	1.0	-	5.5	V	④
CE Low Level Voltage	V _{CEL}	-	-	-	0.3	V	④
CE High Level Current (A/B/E/F/J/K/P/Q Type)	I _{CEH}	V _{CE} =V _{IN} =5.5V	-0.1	-	0.1	μA	④
CE High Level Current (C/D/G/H/M/N/R/T Type)	I _{CEH}	V _{CE} =V _{IN} =5.5V	3.0	5.5	9.0	μA	④
CE Low Level Current	I _{CEL}	V _{CE} =V _{SS}	-0.1	-	0.1	μA	④
C _L Discharge Resistance (Only B/D/F/H/K/N/Q/T Type)	R _{DCHG}	V _{IN} =5.5V, V _{OUT} =2.0V, V _{CE} =V _{SS}	-	300	-	Ω	①
Inrush Current (Only E/F/G/H/P/Q/R/T Type)	I _{rush}	V _{IN} =V _{CE} =5.5V	-	150	-	mA	⑤
Thermal Shutdown Detect Temperature	T _{TSD}	Junction Temperature	-	150	-	°C	①
Thermal Shutdown Release Temperature	T _{TSR}	Junction Temperature	-	120	-	°C	
Thermal Shutdown Hysteresis Width	T _{TSD} - T _{TSR}	Junction Temperature	-	30	-	°C	

NOTE:

(*1) V_{OUT(E)}: Effective output voltage

(i.e. the output voltage when "V_{OUT(T)}+1.0V" is provided at the V_{IN} pin while maintaining a certain I_{OUT} value.)

(*2) V_{OUT(T)}: Nominal output voltage

(*3) The standard output voltage is specified in V_{OUT(T)} ± 20mV where V_{OUT(T)} < 2.0V.

(*4) V_{dif} = {V_{IN1}{*5} - V_{OUT1}{*6}} (V_{IN1} ≥ 1.6V)

(*5) V_{IN1} = The input voltage when V_{OUT1} appears as input voltage is gradually decreased.

(*6) V_{OUT1} = A voltage equal to 98% of the output voltage whenever an amply stabilized I_{OUT} {V_{OUT(T)}+1.0V} is input

(*7) Unless otherwise stated regarding input voltage conditions, V_{IN}=V_{OUT(T)}+1.0V.

■ ELECTRICAL CHARACTERISTICS (Continued)

● Voltage Chart 1

SYMBOL PARAMETER NOMINAL OUTPUT VOLTAGE (V)	E-0 OUTPUT VOLTAGE (V)		E-1 DROPOUT VOLTAGE (mV)	
	V _{OUT(E)}		V _{dif}	
V _{OUT(T)}	MIN	MAX	TYP	MAX
1.20	1.1800	1.2200	480	630
1.25	1.2300	1.2700		
1.30	1.2800	1.3200	440	580
1.35	1.3300	1.3700		
1.40	1.3800	1.4200	420	520
1.45	1.4300	1.4700		
1.50	1.4800	1.5200		
1.55	1.5300	1.5700		
1.60	1.5800	1.6200	400	440
1.65	1.6300	1.6700		
1.70	1.6800	1.7200		
1.75	1.7300	1.7700		
1.80	1.7800	1.8200	300	410
1.85	1.8300	1.8700		
1.90	1.8800	1.9200		
1.95	1.9300	1.9700		
2.00	1.9800	2.0200	270	380
2.05	2.0295	2.0705		
2.10	2.0790	2.1210		
2.15	2.1285	2.1715		
2.20	2.1780	2.2220		
2.25	2.2275	2.2725		
2.30	2.2770	2.3230		
2.35	2.3265	2.3735		
2.40	2.3760	2.4240	240	350
2.45	2.4255	2.4745		
2.50	2.4750	2.5250		
2.55	2.5245	2.5755		
2.60	2.5740	2.6260		
2.65	2.6235	2.6765		
2.70	2.6730	2.7270		
2.75	2.7225	2.7775		

■ ELECTRICAL CHARACTERISTICS (Continued)

● Voltage Chart2

SYMBOL	E-0		E-1	
PARAMETER	OUTPUT VOLTAGE (V)		DROPOUT VOLTAGE (mV)	
NOMINAL OUTPUT VOLTAGE (V)	$V_{OUT(E)}$		V_{dif}	
$V_{OUT(T)}$	MIN.	MAX.	TYP.	MAX.
2.80	2.7720	2.8280	240	350
2.85	2.8215	2.8785		
2.90	2.8710	2.9290		
2.95	2.9205	2.9795		
3.00	2.9700	3.0300	200	305
3.05	3.0195	3.0805		
3.10	3.0690	3.1310		
3.15	3.1185	3.1815		
3.20	3.1680	3.2320		
3.25	3.2175	3.2825		
3.30	3.2670	3.3330		
3.35	3.3165	3.3835		
3.40	3.3660	3.4340		
3.45	3.4155	3.4845		
3.50	3.4650	3.5350		
3.55	3.5145	3.5855		
3.60	3.5640	3.6360		
3.65	3.6135	3.6865		
3.70	3.6630	3.7370		
3.75	3.7125	3.7875		
3.80	3.7620	3.8380		
3.85	3.8115	3.8885		
3.90	3.8610	3.9390		
3.95	3.9105	3.9895		
4.00	3.9600	4.0400		

■ TEST CIRCUITS

● Circuit ①

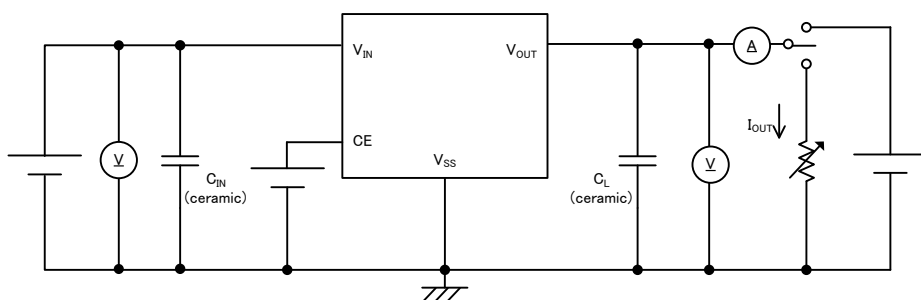

● Circuit ②

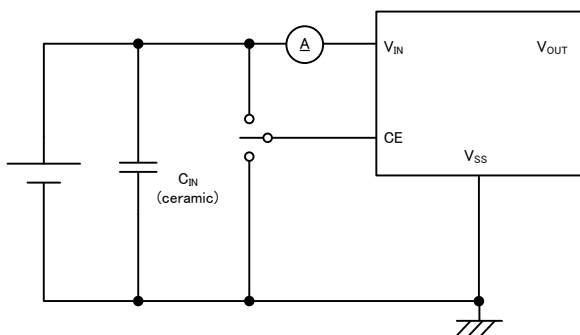

● Circuit ③

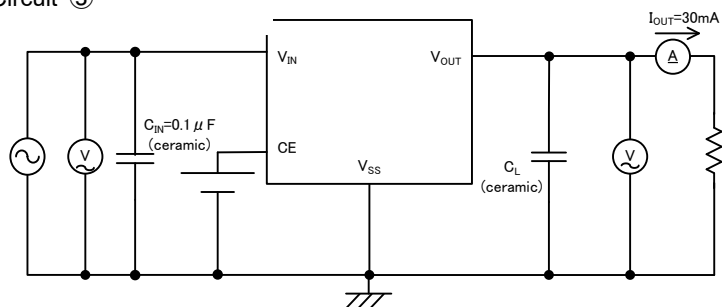

TEST CIRCUITS (Continued)

● Circuit ④

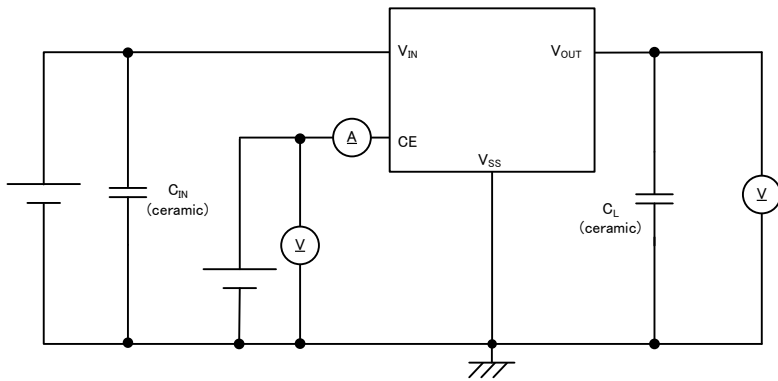

● Circuit ⑤

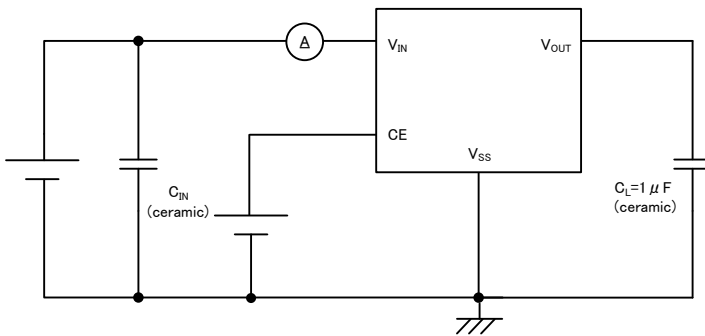

■ OPERATIONAL EXPLANATION

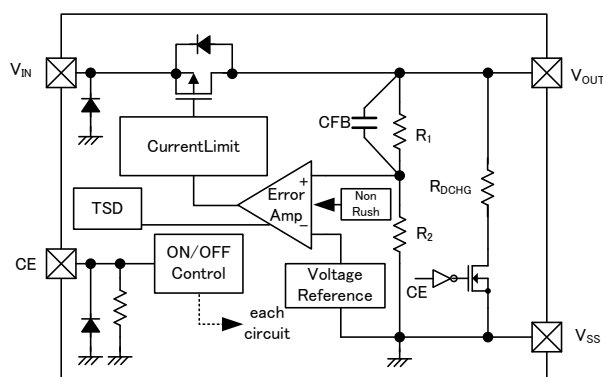

The voltage divided by resistors R1 & R2 is compared with the internal reference voltage by the error amplifier. The P-channel MOSFET which is connected to the Output pin (V_{OUT}) is then driven by the subsequent control signal. The output voltage at the Output pin (V_{OUT}) is controlled and stabilized by a system of negative feedback. The current limit circuit and short circuit protection operate in relation to the level of output current and heat dissipation. Further, the IC's internal circuitry can be shutdown via the CE pin (CE) signal.

<Low ESR Capacitor>

The XC6223 series needs an output capacitor C_L for phase compensation. In order to ensure the stable phase compensation, please place an output capacitor of $1.0\mu\text{F}$ or bigger at the V_{OUT} pin and V_{SS} pin as close as possible. For a stable power input, please connect an input capacitor (C_{IN}) of $1.0\mu\text{F}$ between the input pin (V_{IN}) and the ground pin (V_{SS}).

<Current Limiter, Short-Circuit Protection>

The protection circuit operates as a combination of an output current limiter and fold-back short circuit protection. When load current reaches the current limit level, the output voltage drops. As a result, the load current starts to reduce with showing fold-back curve. When the output is short-circuited, the current drops to the Short Current (I_{short}).

<CE Pin>

The IC's internal circuitry can be shutdown via the signal from the CE pin (CE). In shutdown mode, the XC6223B/D/F/H/K/N/Q/T type enables the electric charge at the output capacitor (C_L) to be discharged via the internal auto-discharge switch, and as a result the output pin (V_{OUT}) quickly returns to the ground pin (V_{SS}) level. When the CE pin (CE) is open, the output voltage becomes undefined state in the XC6223A/B/E/F/J/K/P/Q type because of a high active and no pull-down. On the other hand, the XC6223C/D/G/H/M/N/R/T type has a pull-down resistor at the CE pin (CE) inside, so that the CE pin (CE) input current flows.

<Thermal Shutdown>

When the junction temperature of the built-in driver transistor reaches the temperature limit, the thermal shutdown circuit operates and the driver transistor will be set to OFF. The IC resumes its operation when the thermal shutdown function is released and the IC's operation is automatically restored because the junction temperature drops to the level of the thermal shutdown release voltage.

<Inrush Current Protection>

The E/F/G/H/P/Q, R and T types have a built-in inrush current prevention function.

When the output voltage is about 30% or less of the set voltage after the IC starts up, a short-circuit current flows and the output voltage rises. When the output voltage reaches about 30% of the set voltage, the inrush current prevention function operates for a period of about $120\mu\text{s}$.

While the inrush current prevention function is operating, the inrush current flowing from the input pin (V_{IN}) to the output pin (V_{OUT}) is suppressed not to exceed the I_{rush} (150mA TYP.).

After the inrush current prevention function is released, the current flowing from the input pin to the output pin is limited by the current limit circuit.

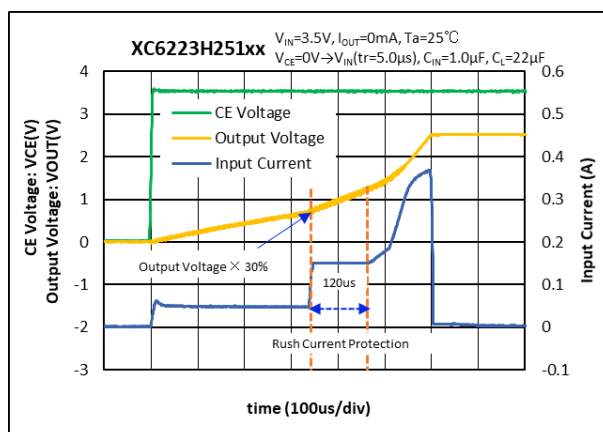

■ NOTES ON USE

1. Where wiring impedance is high, operations may become unstable due to the noise and/or phase lag depending on output current. Please strengthen input pin (V_{IN}) and output pin (V_{OUT}) wiring in particular.
2. The input capacitor C_{IN} and the output capacitor C_L should be placed to the as close as possible with a shorter wiring.
3. The IC is controlled with constant current start-up. Start-up sequence control is requested to draw a load current after even nominal output voltage rising up the output voltage.
4. For temporary, transitional voltage drop or voltage rising phenomenon, the IC is liable to malfunction should the ratings be exceeded.
5. Torex places an importance on improving our products and its reliability.
However, by any possibility, we would request user fail-safe design and post-aging treatment on system or equipment.

■ TYPICAL PERFORMANCE CHARACTERISTICS

(1) Output Voltage vs. Output Current

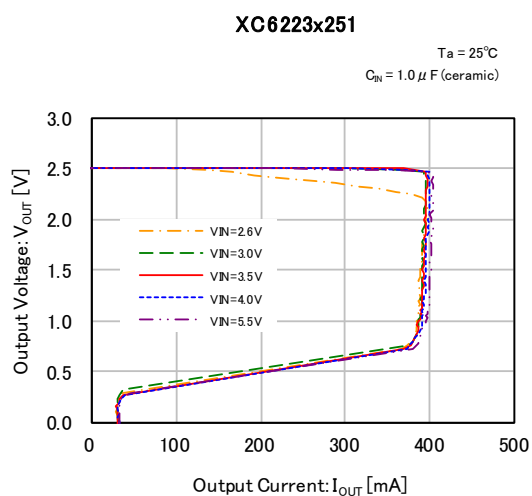
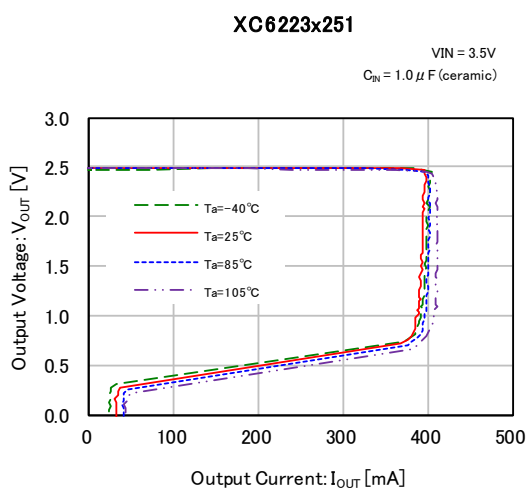
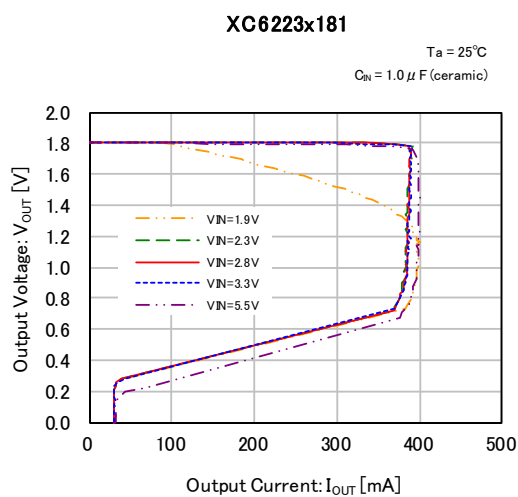
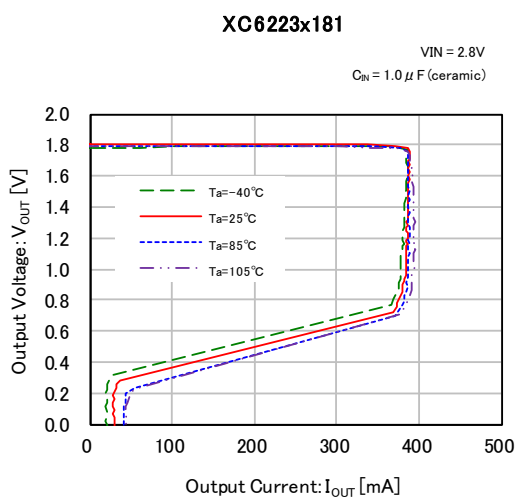
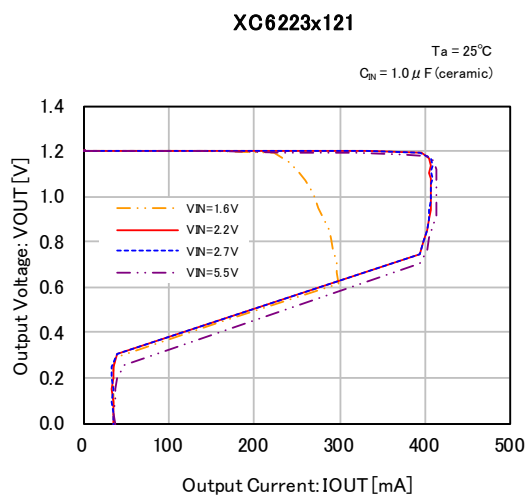
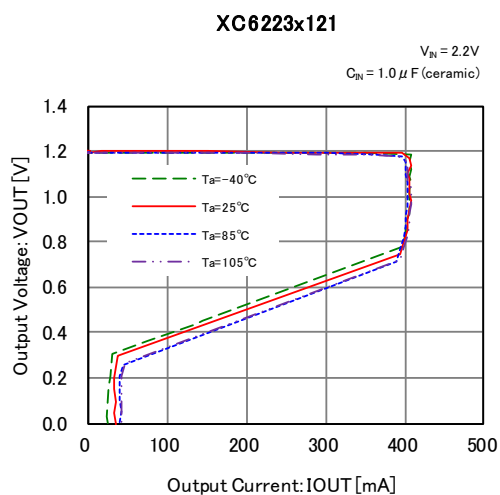

TYPICAL PERFORMANCE CHARACTERISTICS (Continued)

(1) Output Voltage vs. Output Current (Continued)

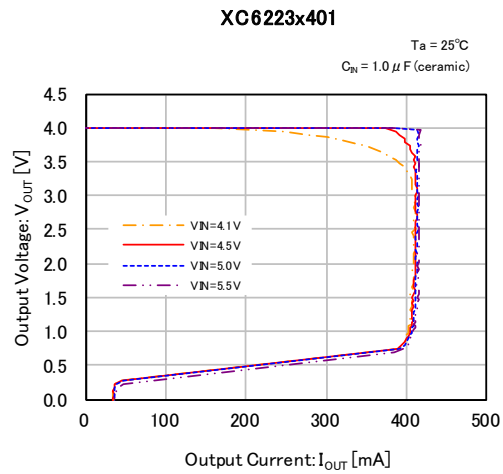
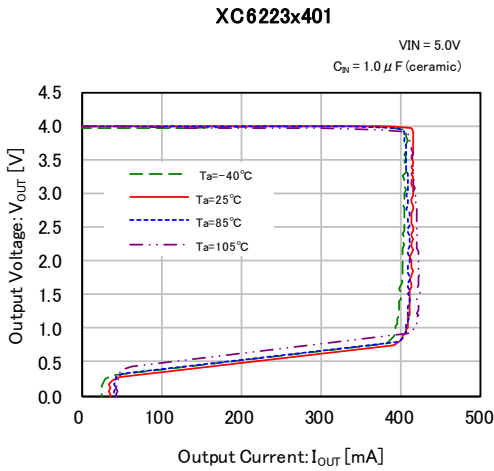

(2) Output Voltage vs. Input Voltage

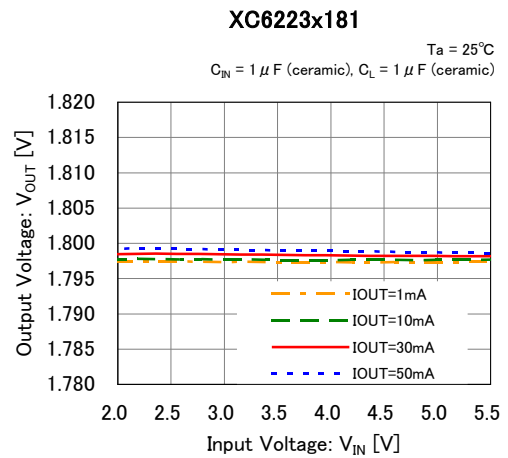
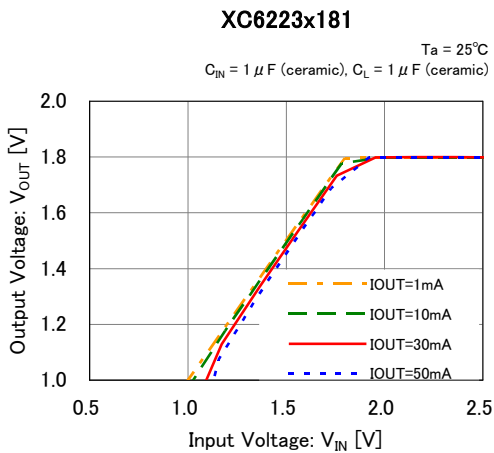
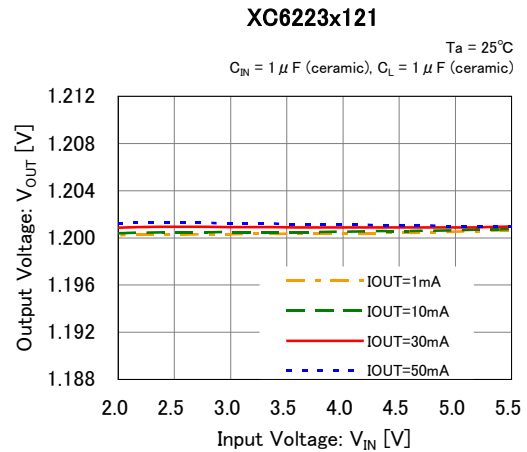
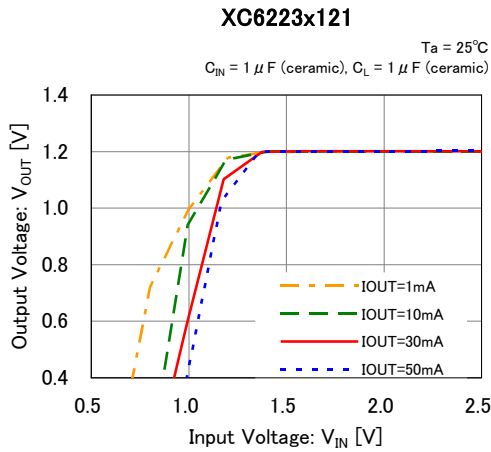

■ TYPICAL PERFORMANCE CHARACTERISTICS (Continued)

(2) Output Voltage vs. Input Voltage (Continued)

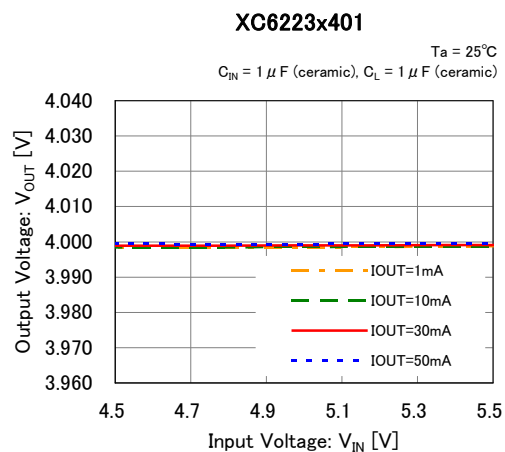
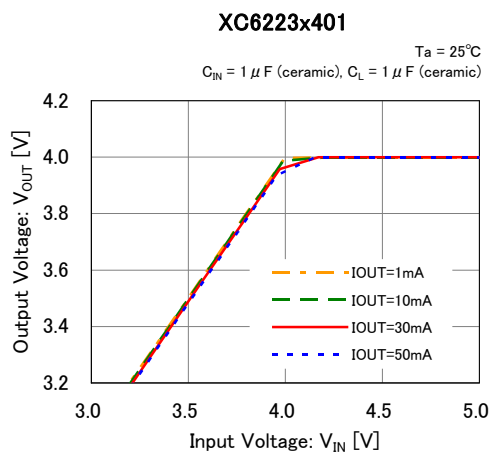
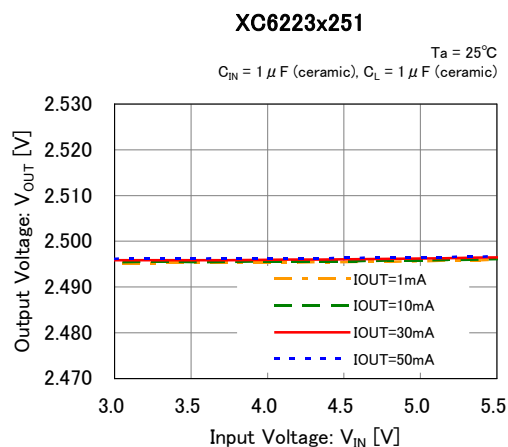
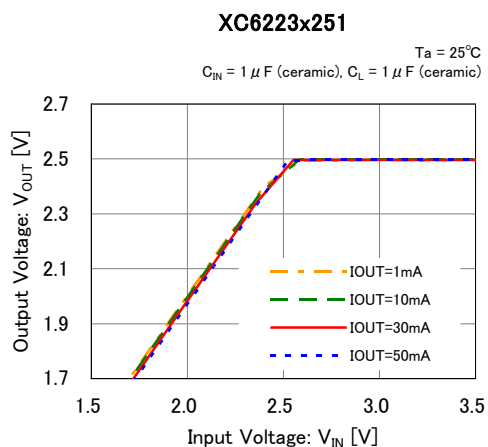

(3) Dropout Voltage vs. Output Current

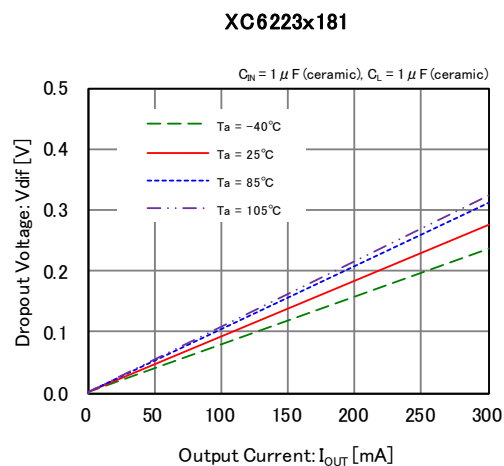
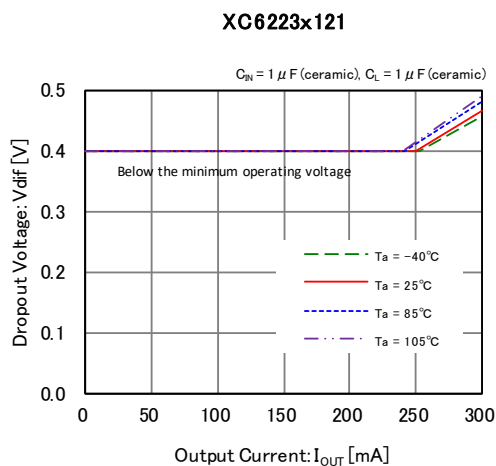

TYPICAL PERFORMANCE CHARACTERISTICS (Continued)

(3) Dropout Voltage vs. Output Current (Continued)

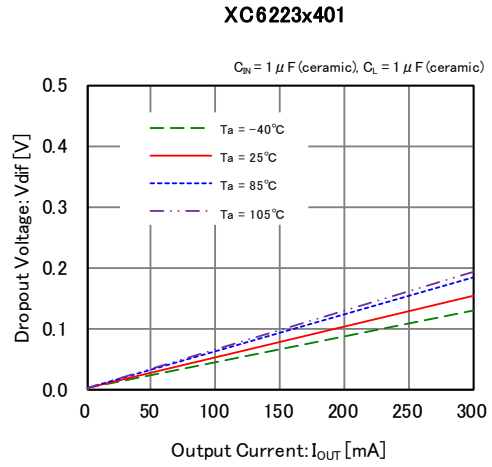
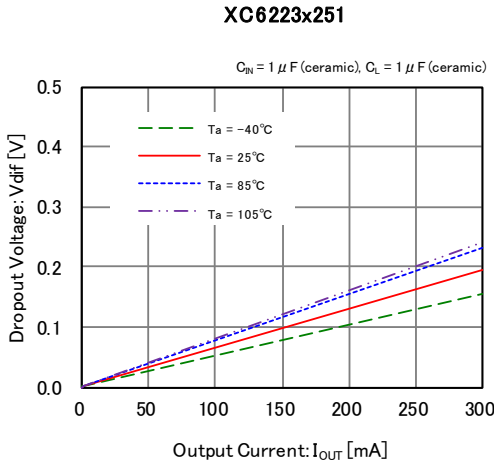

(4) Supply Current vs. Input Voltage

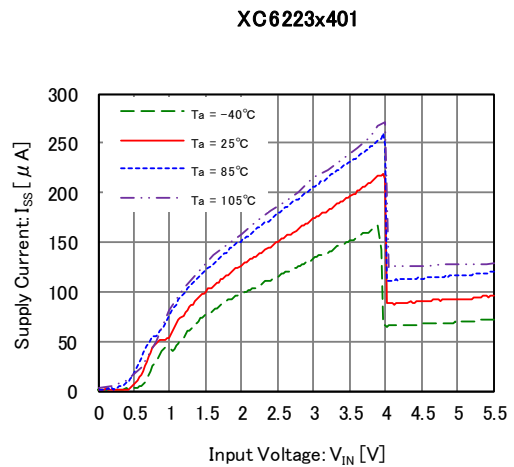
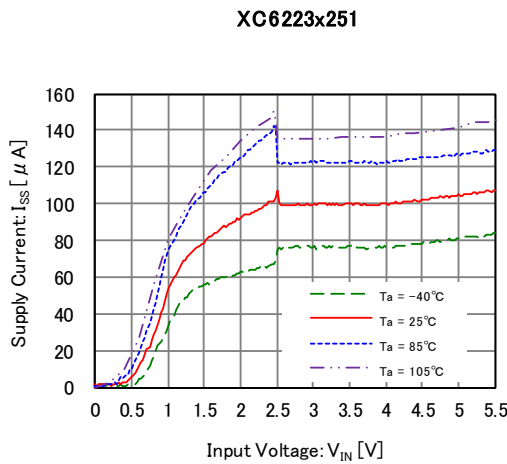
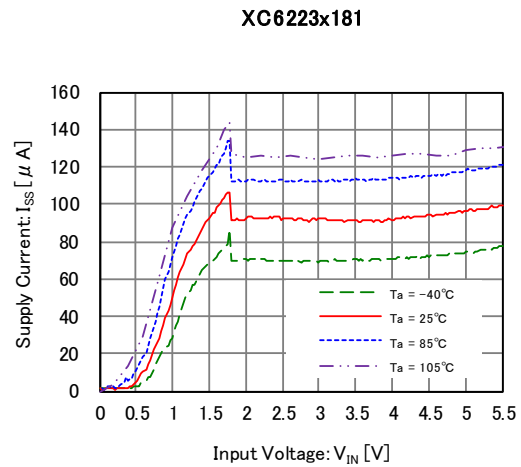
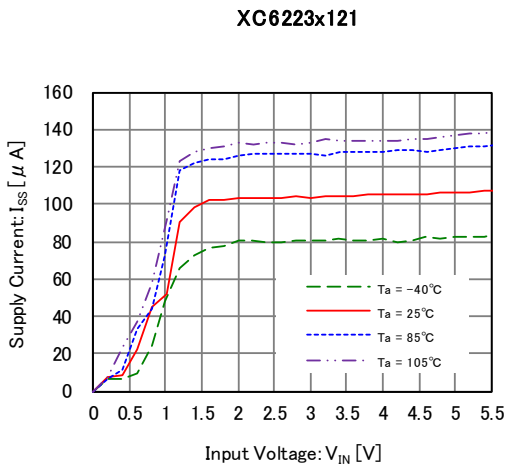

TYPICAL PERFORMANCE CHARACTERISTICS (Continued)

(5) Output Voltage vs. Ambient Temperature

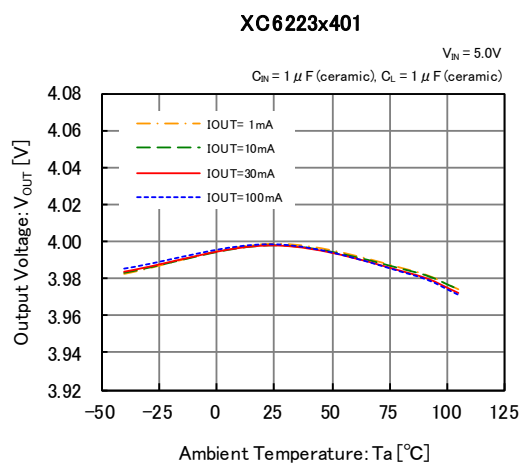
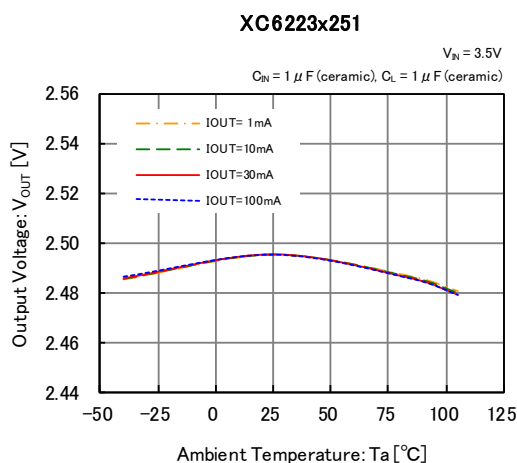
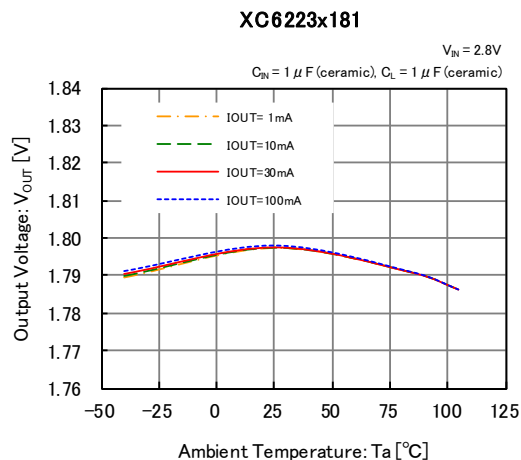
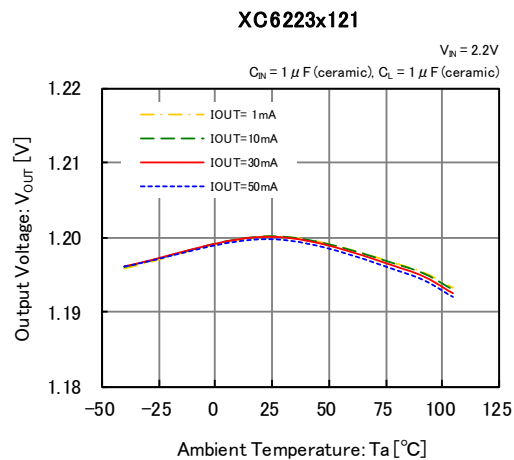

(6) Rising Response Time

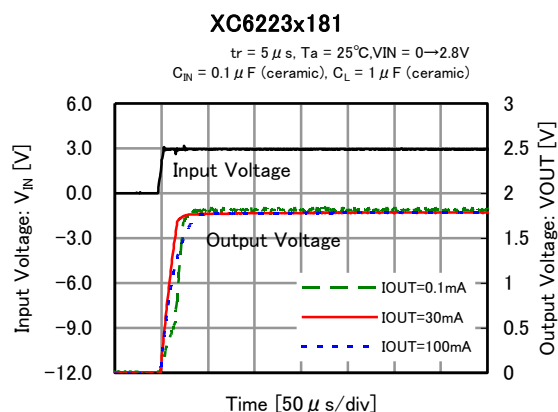
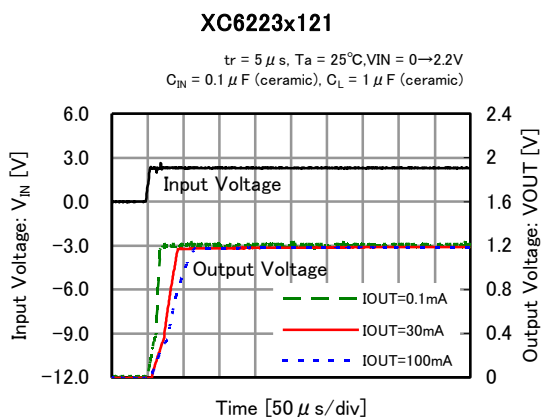

TYPICAL PERFORMANCE CHARACTERISTICS (Continued)

(6) Rising Response Time (Continued)

XC6223x251

$t_r = 5 \mu s$, $T_a = 25^\circ C$, $V_{IN} = 0 \rightarrow 3.5V$
 $C_{IN} = 0.1 \mu F$ (ceramic), $C_L = 1 \mu F$ (ceramic)

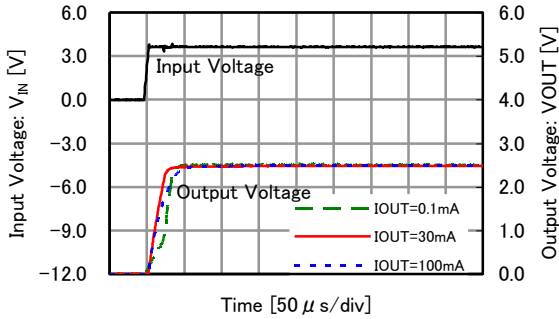

XC6223x401

$t_r = 5 \mu s$, $T_a = 25^\circ C$, $V_{IN} = 0 \rightarrow 5.0V$
 $C_{IN} = 0.1 \mu F$ (ceramic), $C_L = 1 \mu F$ (ceramic)

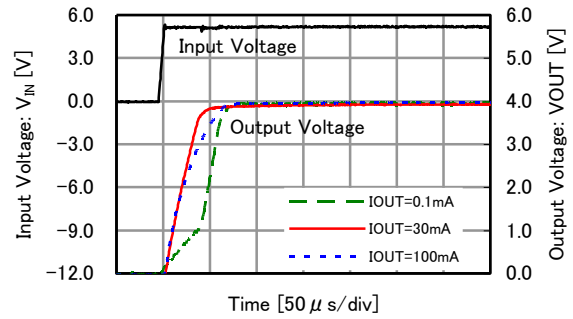

(7) Input Transient Response

XC6223x121

$t_r = t_f = 5 \mu s$, $T_a = 25^\circ C$, $V_{IN} = 2.2V \leftrightarrow 3.2V$
 $C_{IN} = 0.1 \mu F$ (ceramic), $C_L = 1.0 \mu F$ (ceramic)

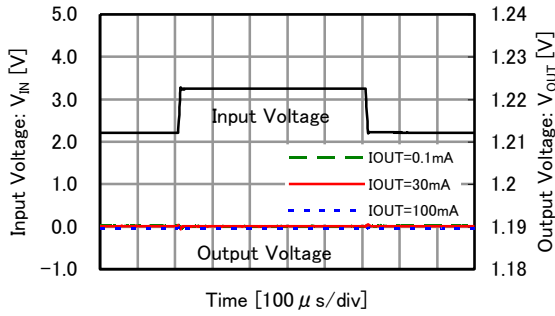

XC6223x181

$t_r = t_f = 5 \mu s$, $T_a = 25^\circ C$, $V_{IN} = 2.8V \leftrightarrow 3.8V$
 $C_{IN} = 0.1 \mu F$ (ceramic), $C_L = 1.0 \mu F$ (ceramic)

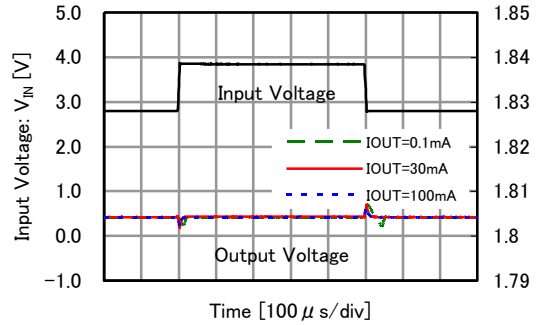

XC6223x251

$t_r = t_f = 5 \mu s$, $T_a = 25^\circ C$, $V_{IN} = 3.5V \leftrightarrow 4.5V$
 $C_{IN} = 0.1 \mu F$ (ceramic), $C_L = 1.0 \mu F$ (ceramic)

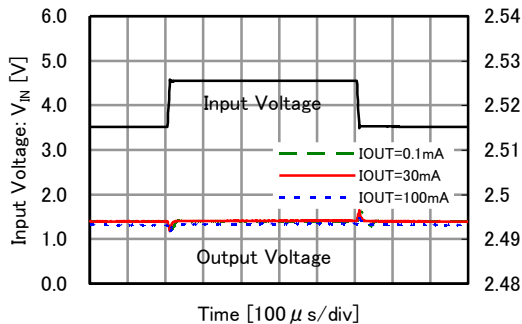

XC6223x401

$t_r = t_f = 5 \mu s$, $T_a = 25^\circ C$, $V_{IN} = 4.5V \leftrightarrow 5.5V$
 $C_{IN} = 0.1 \mu F$ (ceramic), $C_L = 1.0 \mu F$ (ceramic)

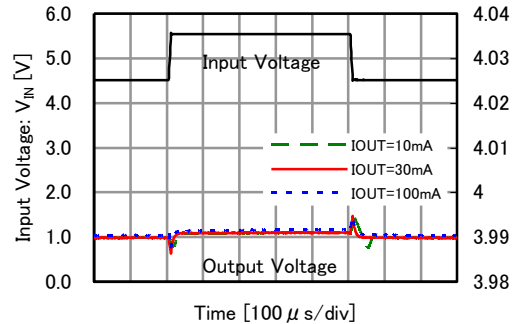

■ TYPICAL PERFORMANCE CHARACTERISTICS (Continued)

(8) Load Transient Response ($t_r=t_f=0.5\mu s$)

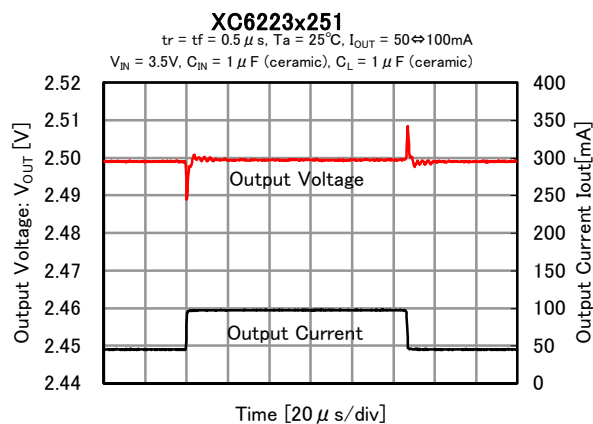
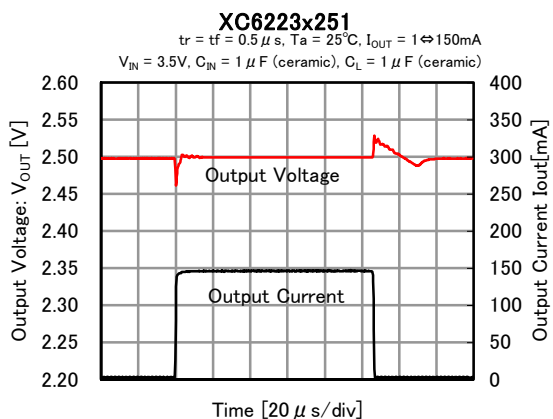
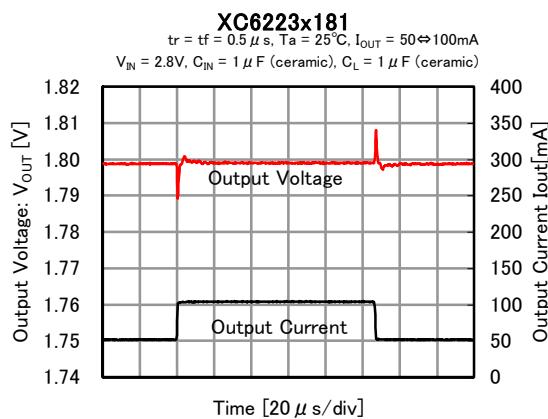
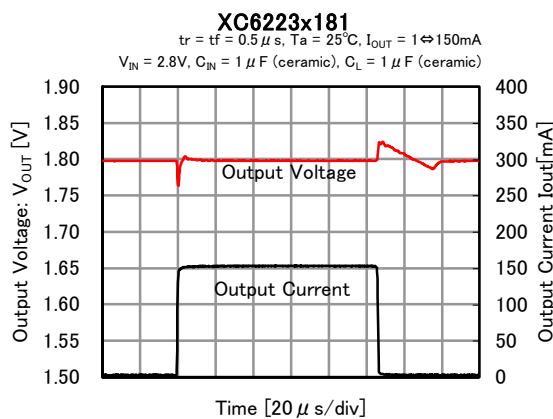
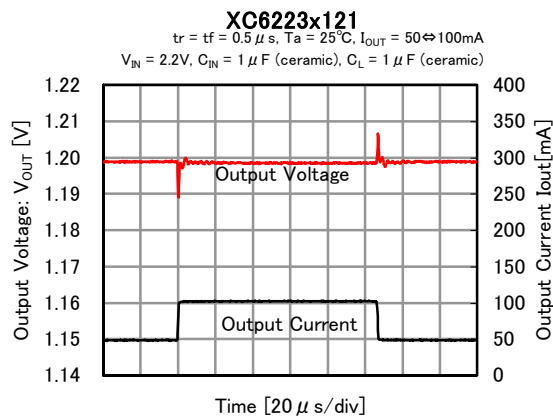
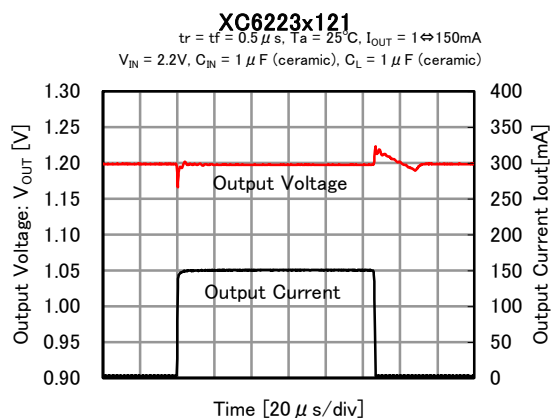

TYPICAL PERFORMANCE CHARACTERISTICS (Continued)

(8) Load Transient Response ($t_r=t_f=0.5\mu s$) (Continued)

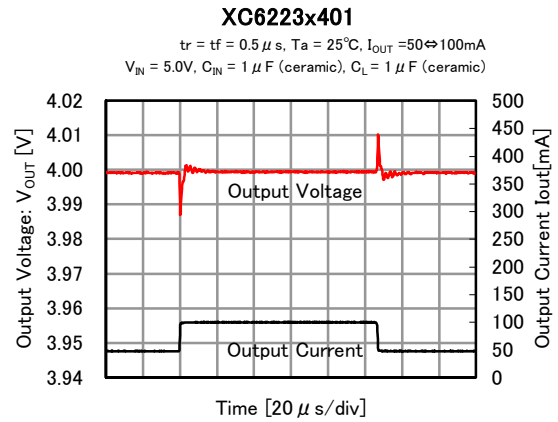
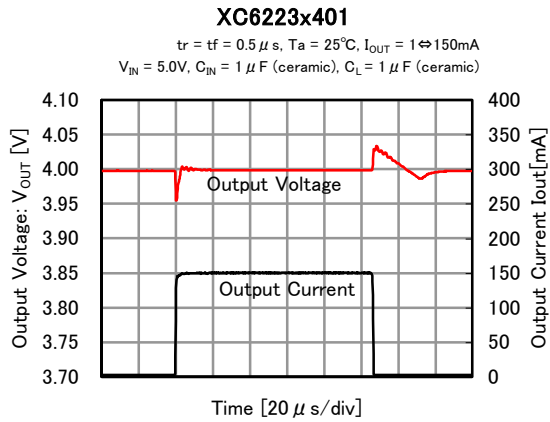

(8) Load Transient Response ($t_r=t_f=5\mu s$) (Continued)

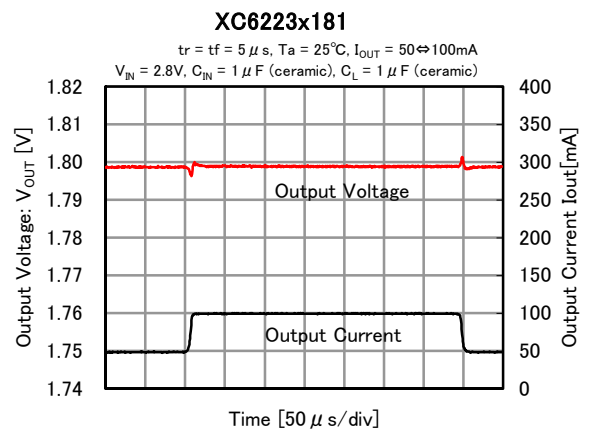
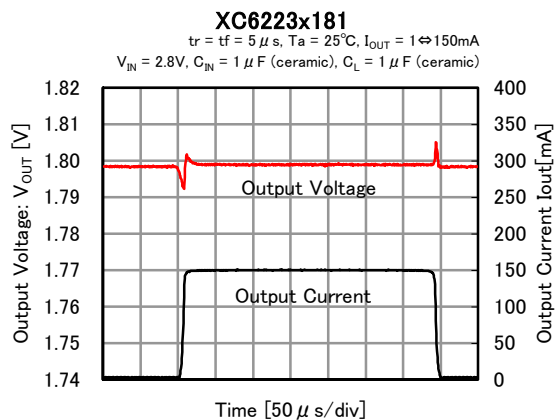
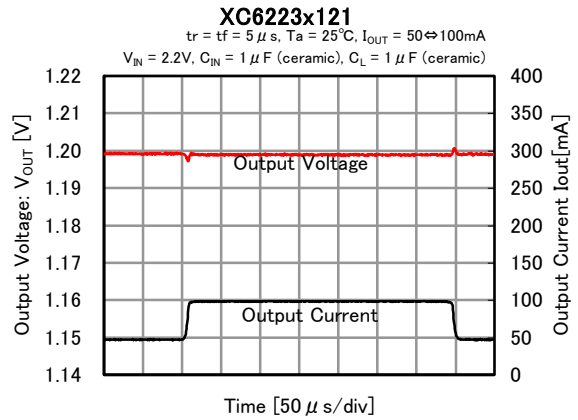
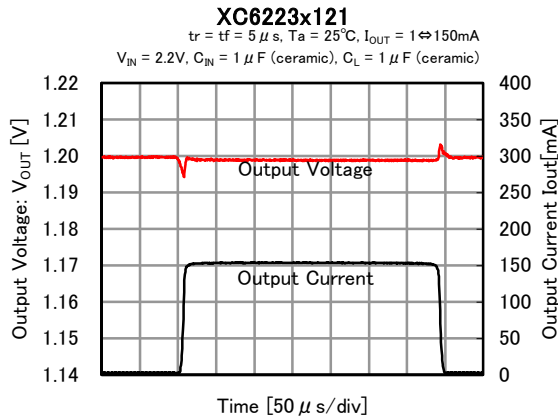

■ TYPICAL PERFORMANCE CHARACTERISTICS (Continued)

(8) Load Transient Response ($t_r=t_f=5\mu s$) (Continued)

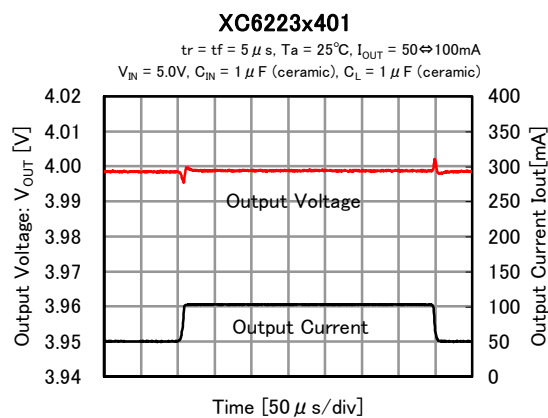
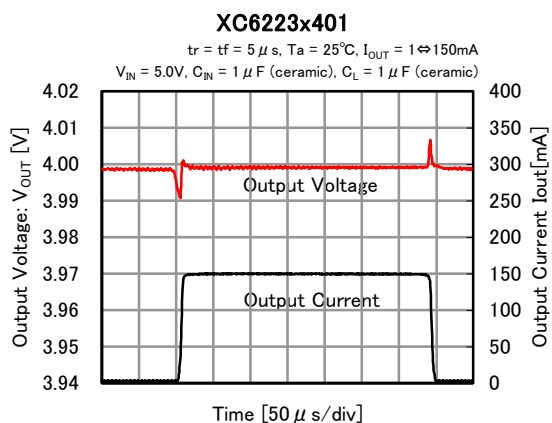
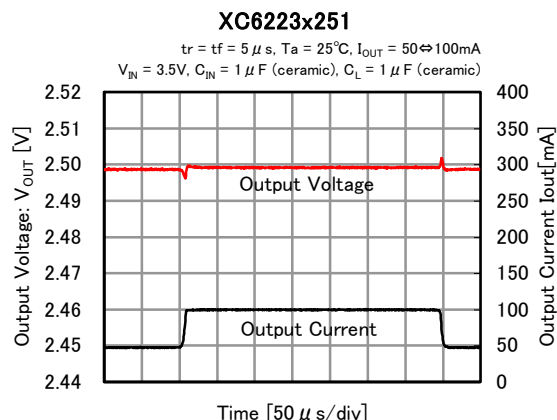
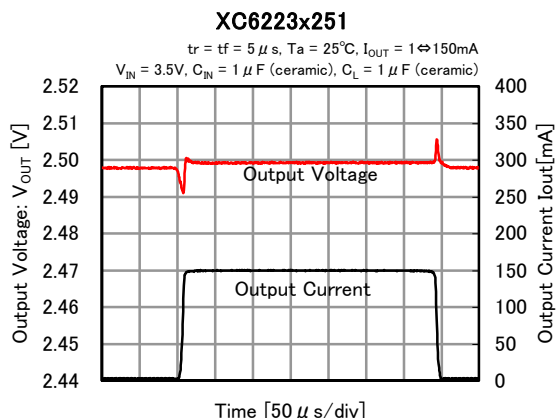

(9) CE Rising Response Time (A,B,C,D J,K,M,N Type)

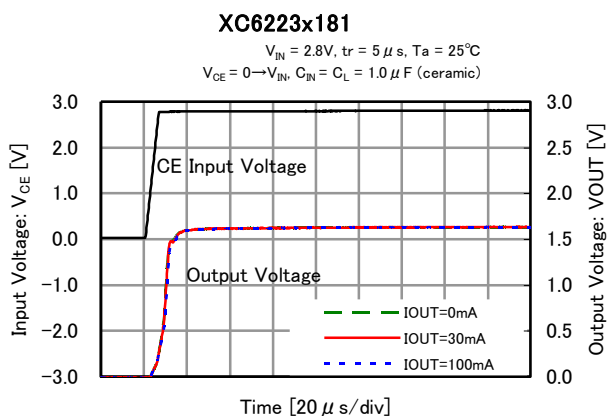
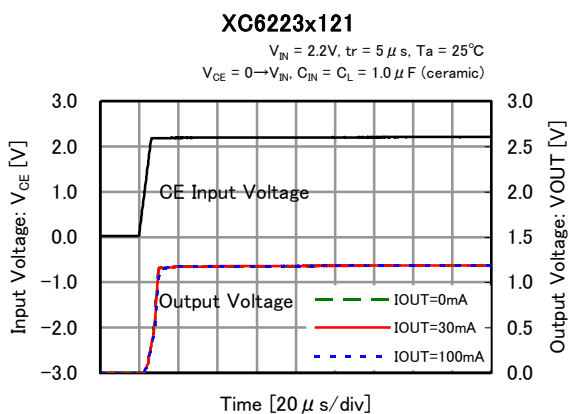

TYPICAL PERFORMANCE CHARACTERISTICS (Continued)

(9) CE Rising Response Time (A,B,C,D,J,K,M,N Type) (Continued)

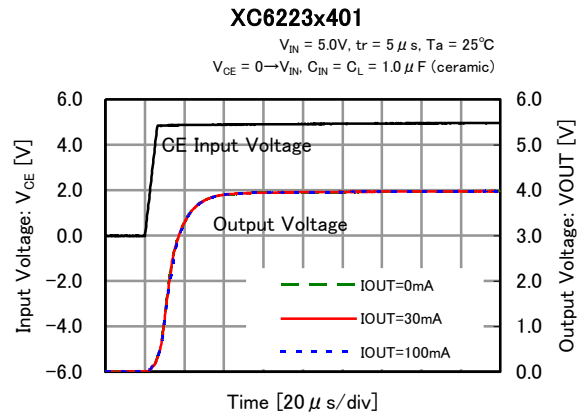
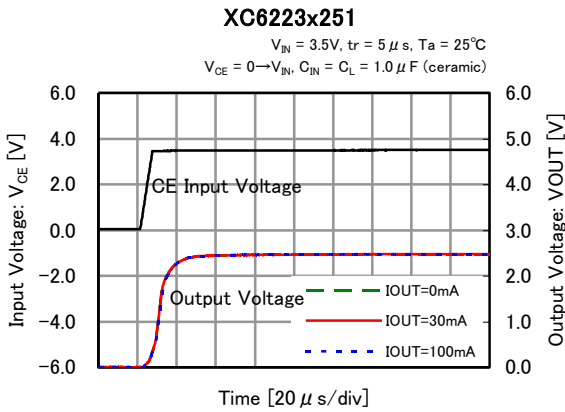

(9) CE Rising Response Time (E,F,G,H,P,Q,R,T Type) (Continued)

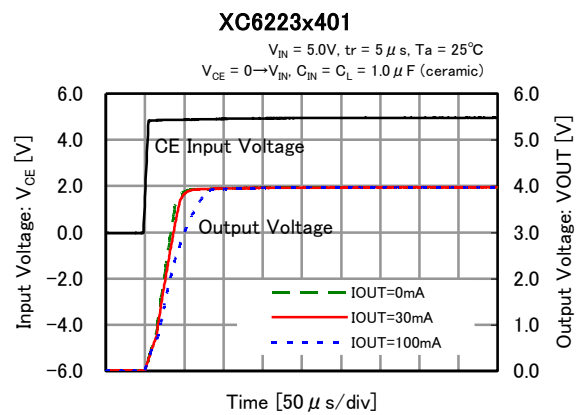
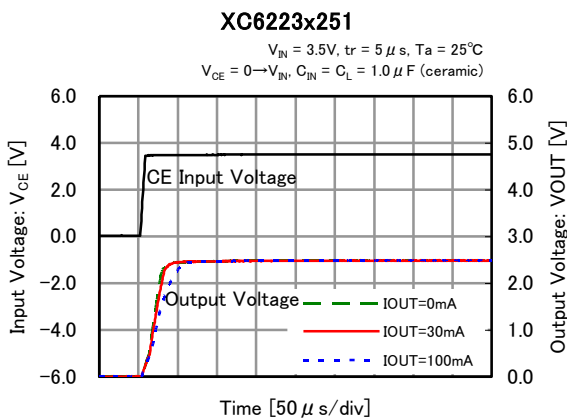
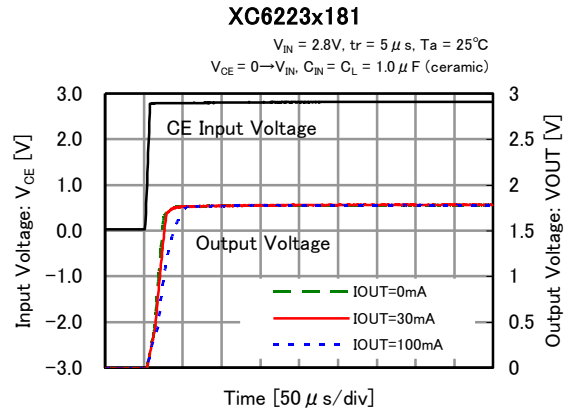
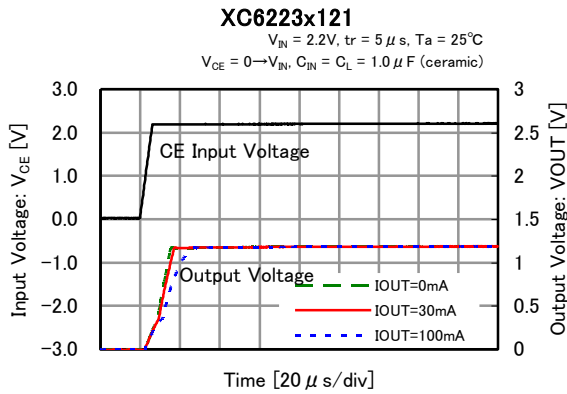

■ TYPICAL PERFORMANCE CHARACTERISTICS (Continued)

(10) Inrush Current Response Time (E,F,G,H,P,Q,R,T Type)

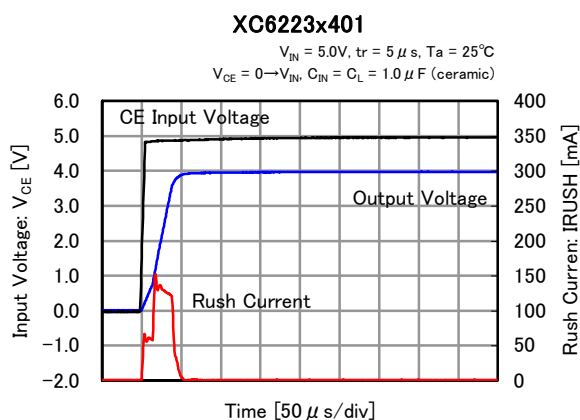
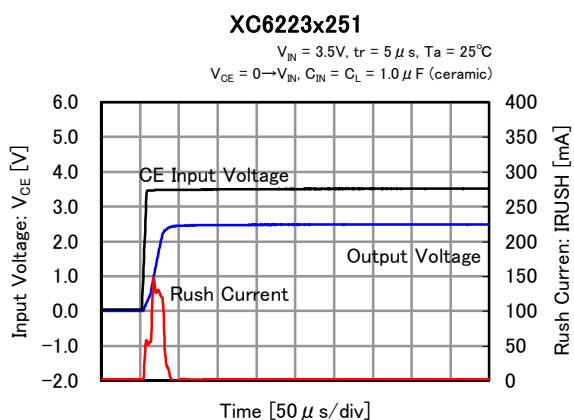
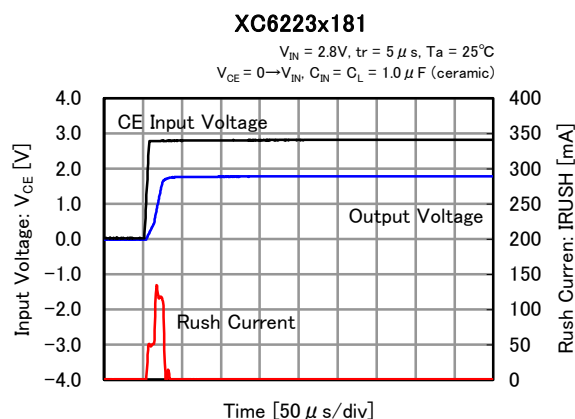
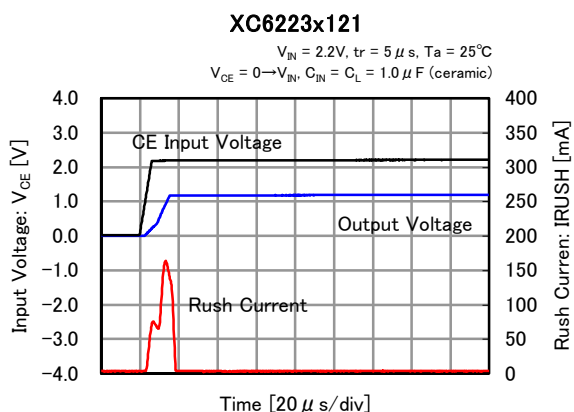

TYPICAL PERFORMANCE CHARACTERISTICS (Continued)

(11) Ripple Rejection Rate

XC6223x121

$T_a = 25^\circ\text{C}$, $V_{IN} = 3.0\text{VDC} + 0.5\text{Vp-pAC}$
 $C_{IN} = 0.1 \mu\text{F}$ (ceramic), $C_L = 1 \mu\text{F}$ (ceramic)

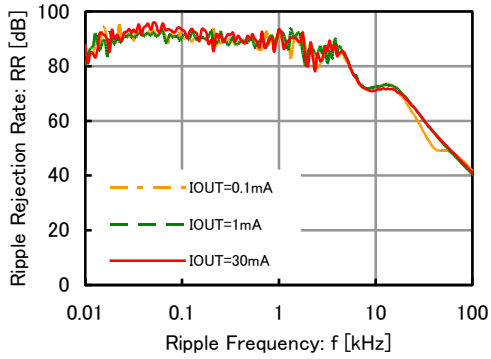

XC6223x181

$T_a = 25^\circ\text{C}$, $V_{IN} = 3.0\text{VDC} + 0.5\text{Vp-pAC}$
 $C_{IN} = 0.1 \mu\text{F}$ (ceramic), $C_L = 1 \mu\text{F}$ (ceramic)

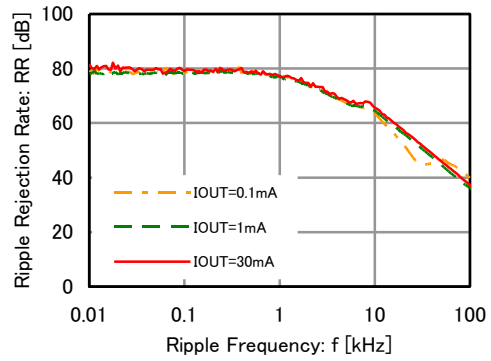

XC6223x251

$T_a = 25^\circ\text{C}$, $V_{IN} = 3.5\text{VDC} + 0.5\text{Vp-pAC}$
 $C_{IN} = 0.1 \mu\text{F}$ (ceramic), $C_L = 1 \mu\text{F}$ (ceramic)

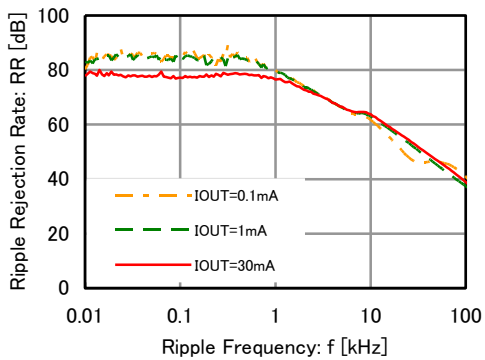

XC6223x331

$T_a = 25^\circ\text{C}$, $V_{IN} = 4.3\text{VDC} + 0.5\text{Vp-pAC}$
 $C_{IN} = 0.1 \mu\text{F}$ (ceramic), $C_L = 1 \mu\text{F}$ (ceramic)

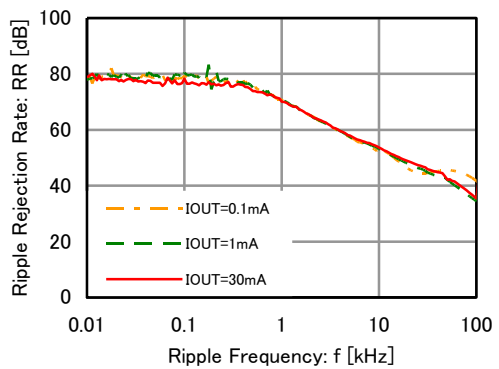

■ TYPICAL PERFORMANCE CHARACTERISTICS (Continued)

(12) Output Noise Density

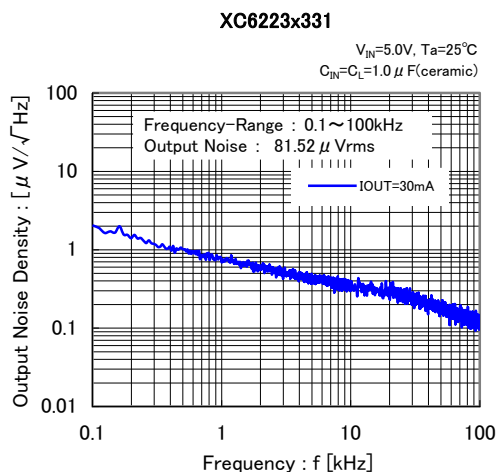
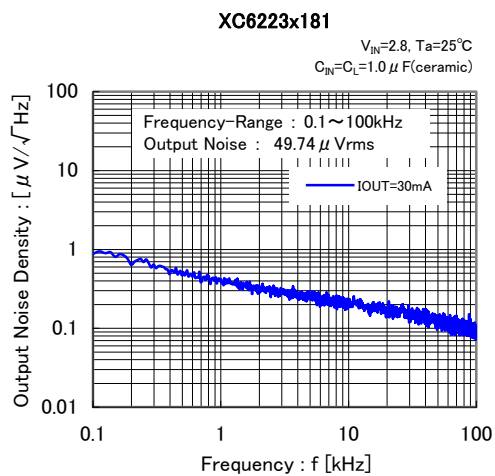
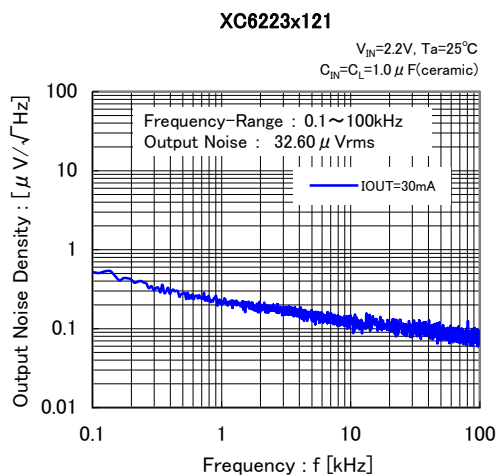

■ PACKAGING INFORMATION

For the latest package information go to, www.torexsemi.com/technical-support/packages

PACKAGE	OUTLINE / LAND PATTERN	THERMAL CHARACTERISTICS
USPQ-4B03	USPQ-4B03 PKG	USPQ-4B03 Power Dissipation
USP-4	USP-4 PKG	USP-4 Power Dissipation
SSOT-24	SSOT-24 PKG	SSOT-24 Power Dissipation
SOT-25	SOT-25 PKG	SOT-25 Power Dissipation
SOT-89-5	SOT-89-5 PKG	SOT-89-5 Power Dissipation

MARKING RULE

● USPQ-4B03

① represents type of regulator and output voltage range.

MARK			PRODUCT SERIES
OUTPUT VOLTAGE 0.1V INCREMENTS		OUTPUT VOLTAGE 0.05V INCREMENTS	
VOLTAGE=1.2~3.9V	VOLTAGE =4.0V	VOLTAGE =1.25~3.95V	
0	H	8	XC6223A/J*****
1		9	XC6223B/K*****
2		A	XC6223C/M*****
3		B	XC6223D/N*****
4		C	XC6223E/P*****
5		D	XC6223F/Q*****
6		E	XC6223G/R*****
7		F	XC6223H/T*****

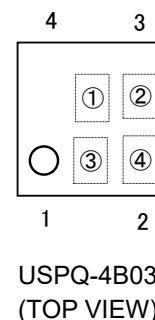

② represents output voltage.

VOLTAGE=1.2~3.95[V]

MARK	OUTPUT VOLTAGE (V)		MARK	OUTPUT VOLTAGE (V)	
0	-	-	F	2.50	2.55
1	-	-	H	2.60	2.65
2	1.20	1.25	K	2.70	2.75
3	1.30	1.35	L	2.80	2.85
4	1.40	1.45	M	2.90	2.95
5	1.50	1.55	N	3.00	3.05
6	1.60	1.65	P	3.10	3.15
7	1.70	1.75	R	3.20	3.25
8	1.80	1.85	S	3.30	3.35
9	1.90	1.95	T	3.40	3.45
A	2.00	2.05	U	3.50	3.55
B	2.10	2.15	V	3.60	3.65
C	2.20	2.25	X	3.70	3.75
D	2.30	2.35	Y	3.80	3.85
E	2.40	2.45	Z	3.90	3.95

VOLTAGE=4.0[V]

PRODUCT SERIES	MARK
XC6223A/J*****	0
XC6223B/K*****	1
XC6223C/M*****	2
XC6223D/N*****	3
XC6223E/P*****	4
XC6223F/Q*****	5
XC6223G/R*****	6
XC6223H/T*****	7

③④ represents production lot number.

01 to 09, 0A to 0Z, 11 to 9Z, A1 to A9, AA to Z9, ZA to ZZ in order.

(G, I, J, O, Q, W excepted)

*No character inversion used.

MARKING RULE (Continued)

●SSOT-24 (with bar)

① represents type of regulator and output voltage range.

MARK			PRODUCT SERIES
OUTPUT VOLTAGE 0.1V INCREMENTS		OUTPUT VOLTAGE 0.05V INCREMENTS	
VOLTAGE =1.2~ 2.9V	VOLTAGE =3.0 ~4.0V	VOLTAGE =1.25~ 3.95V	
B	3	8	XC6223A/J*****
C	5	9	XC6223B/K*****
D	7	S	XC6223C/M*****
E	A	T	XC6223D/N*****
K	F	U	XC6223E/P*****
L	H	V	XC6223F/Q*****
M	P	X	XC6223G/R*****
N	Z	Y	XC6223H/T*****

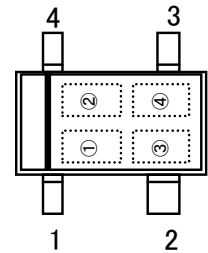

SSOT-24(with bar)
(TOP VIEW)

② represents output voltage.

MARK	OUTPUT VOLTAGE (V)				MARK	OUTPUT VOLTAGE (V)			
0	-	-	-	-	F	2.50	3.20	-	2.55
1	-	-	-	-	H	2.60	3.30	-	2.65
2	1.20	-	-	1.25	K	2.70	3.40	-	2.75
3	1.30	-	-	1.35	L	2.80	3.50	-	2.85
4	1.40	-	-	1.45	M	2.90	3.60	-	2.95
5	1.50	-	-	1.55	N	-	-	-	3.05
6	1.60	-	-	1.65	P	-	3.70	-	3.15
7	1.70	-	-	1.75	R	-	3.80	-	3.25
8	1.80	-	-	1.85	S	-	3.90	-	3.35
9	1.90	-	-	1.95	T	-	4.00	-	3.45
A	2.00	-	-	2.05	U	-	-	-	3.55
B	2.10	-	-	2.15	V	-	-	-	3.65
C	2.20	-	-	2.25	X	-	-	-	3.75
D	2.30	3.00	-	2.35	Y	-	-	-	3.85
E	2.40	3.10	-	2.45	Z	-	-	-	3.95

③④ represents production lot number.

01 to 09, 0A to 0Z, 11 to 9Z, A1 to A9, AA to Z9, ZA to ZZ in order.

(G, I, J, O, Q, W excepted)

*No character inversion used.

MARKING RULE (Continued)

●SOT-25, SOT-89-5, USP-4

① represents product series

MARK	PRODUCT SERIES
9	XC6223*****

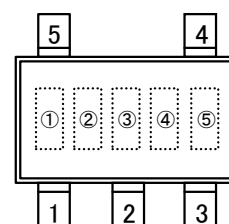

SOT-25
(TOP VIEW)

② represents type of regulator.

MARK			PRODUCT SERIES
OUTPUT VOLTAGE 0.1V INCREMENTS		OUTPUT VOLTAGE 0.05V INCREMENTS	
VOLTAGE =1.2~ 3.9V	VOLTAGE =4.0V	VOLTAGE =1.25~ 3.95V	
C	D	E	XC6223A/J*****
F	H	K	XC6223B/K*****
L	M	N	XC6223C/M*****
P	R	S	XC6223D/N*****
T	U	V	XC6223E/P*****
X	Y	Z	XC6223F/Q*****
0	1	2	XC6223G/R*****
3	4	5	XC6223H/T*****

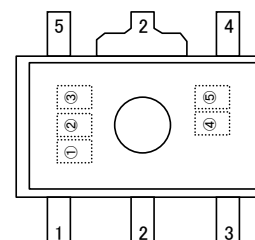

SOT-89-5
(TOP VIEW)

③ represents output voltage.

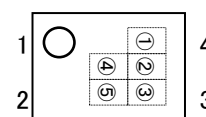

USP-4
(TOP VIEW)

MARK	OUTPUT VOLTAGE (V)				MARK	OUTPUT VOLTAGE (V)			
0	-	4.00	-	-	F	2.50	-	2.55	-
1	-	-	-	-	H	2.60	-	2.65	-
2	1.20	-	1.25	-	K	2.70	-	2.75	-
3	1.30	-	1.35	-	L	2.80	-	2.85	-
4	1.40	-	1.45	-	M	2.90	-	2.95	-
5	1.50	-	1.55	-	N	3.00	-	3.05	-
6	1.60	-	1.65	-	P	3.10	-	3.15	-
7	1.70	-	1.75	-	R	3.20	-	3.25	-
8	1.80	-	1.85	-	S	3.30	-	3.35	-
9	1.90	-	1.95	-	T	3.40	-	3.45	-
A	2.00	-	2.05	-	U	3.50	-	3.55	-
B	2.10	-	2.15	-	V	3.60	-	3.65	-
C	2.20	-	2.25	-	X	3.70	-	3.75	-
D	2.30	-	2.35	-	Y	3.80	-	3.85	-
E	2.40	-	2.45	-	Z	3.90	-	3.95	-

④⑤ represents production lot number.

01 to 09, 0A to 0Z, 11 to 9Z, A1 to A9, AA to Z9, ZA to ZZ in order.

(G, I, J, O, Q, W excepted)

*No character inversion used.

1. The product and product specifications contained herein are subject to change without notice to improve performance characteristics. Consult us, or our representatives before use, to confirm that the information in this datasheet is up to date.
2. The information in this datasheet is intended to illustrate the operation and characteristics of our products. We neither make warranties or representations with respect to the accuracy or completeness of the information contained in this datasheet nor grant any license to any intellectual property rights of ours or any third party concerning with the information in this datasheet.
3. Applicable export control laws and regulations should be complied and the procedures required by such laws and regulations should also be followed, when the product or any information contained in this datasheet is exported.
4. The product is neither intended nor warranted for use in equipment of systems which require extremely high levels of quality and/or reliability and/or a malfunction or failure which may cause loss of human life, bodily injury, serious property damage including but not limited to devices or equipment used in 1) nuclear facilities, 2) aerospace industry, 3) medical facilities, 4) automobile industry and other transportation industry and 5) safety devices and safety equipment to control combustions and explosions. Do not use the product for the above use unless agreed by us in writing in advance.
5. Although we make continuous efforts to improve the quality and reliability of our products; nevertheless Semiconductors are likely to fail with a certain probability. So in order to prevent personal injury and/or property damage resulting from such failure, customers are required to incorporate adequate safety measures in their designs, such as system fail safes, redundancy and fire prevention features.
6. Our products are not designed to be Radiation-resistant.
7. Please use the product listed in this datasheet within the specified ranges.
8. We assume no responsibility for damage or loss due to abnormal use.
9. All rights reserved. No part of this datasheet may be copied or reproduced unless agreed by Torex Semiconductor Ltd in writing in advance.

TOREX SEMICONDUCTOR LTD.

X-ON Electronics

Largest Supplier of Electrical and Electronic Components

Click to view similar products for [LDO Voltage Regulators](#) category:

Click to view products by [Torex Semiconductor](#) manufacturer:

Other Similar products are found below :

[AP7363-SP-13](#) [NCV8664CST33T3G](#) [L79M05TL-E](#) [AP7362-HA-7](#) [PT7M8202B12TA5EX](#) [TCR3DF185,LM\(CT](#) [TLF4949EJ](#)
[NCP4687DH15T1G](#) [NCV8703MX30TCG](#) [LP2951CN](#) [NCV4269CPD50R2G](#) [AP7315-25W5-7](#) [NCV47411PAAJR2G](#) [AP2111H-1.2TRG1](#)
[ZLDO1117QK50TC](#) [AZ1117ID-ADJTRG1](#) [NCV4263-2CPD50R2G](#) [NCP114BMX075TCG](#) [MC33269T-3.5G](#) [TLE4471GXT](#) [AP7315-33SA-](#)
[7](#) [NCV4266-2CST33T3G](#) [NCP715SQ15T2G](#) [NCV8623MN-50R2G](#) [NCV563SQ18T1G](#) [NCV8664CDT33RKG](#) [NCV4299CD250R2G](#)
[NCV8702MX25TCG](#) [TLE7270-2E](#) [NCV562SQ25T1G](#) [AP2213D-3.3TRG1](#) [AP2202K-2.6TRE1](#) [NCV8170BMX300TCG](#)
[NCV8152MX300180TCG](#) [NCP700CMT45TBG](#) [AP7315-33W5-7](#) [NCP154MX180300TAG](#) [AP2113AMTR-G1](#) [NJW4104U2-33A-TE1](#)
[MP2013AGG-5-P](#) [NCV8775CDT50RKG](#) [NJM2878F3-45-TE1](#) [S-19214B00A-V5T2U7](#) [S-19214B50A-V5T2U7](#) [S-19213B50A-V5T2U7](#) [S-](#)
[19214BC0A-E8T1U7*1](#) [S-19213B00A-V5T2U7](#) [S-19213B33A-V5T2U7](#) [S-19213BC0A-V5T2U7](#) [S-1313D18-N4T1U4](#)