

## Charge Pump Voltage Inverter IC

## ■ GENERAL DESCRIPTION

The XC6351A series are charge pump voltage inverter ICs that have 4 MOSFETs built in. Since highly efficient negative voltages can be generated with only 2 external capacitors connected, GaAs bias power supplies & OpAmp's negative power supplies etc., can be easily accommodated on a standard PCB.

A mini-molded, 6 pin, SOT-26 and USP-6B packages provides for space saving and makes high density mounting possible. Low power consumption and high efficiency make this series perfect for use with battery operated applications.

Since the IC's operations stop when output is shutdown via the CE (chip enable) function, total power consumption reduction is possible in applications which use this IC.

## ■ APPLICATIONS

- Negative power supplies
- Power supplies for Opamp
- Cellular and portable phones
- Miniature LCD panels
- PDAs
- Various battery powered systems

## ■ FEATURES

<b>Operating Voltage Range</b>	: 1.2V ~ 5.0V
<b>Oscillation Frequency</b>	: 120kHz : 35kHz ( custom )
<b>Low Supply Current</b>	: 310 $\mu$ A ( TYP. ) : 100 $\mu$ A (35kHz custom TYP.)
<b>High Efficiency</b>	: 90% (TYP.) ( RL = 2k $\Omega$ )
<b>Stand-by Current</b>	: 2.0 $\mu$ A (MAX.)
<b>CE(Chip Enable) Function</b>	
<b>Operating Ambient Temperature</b>	: -30°C ~ +80°C
<b>Packages</b>	: SOT-26 ,USP-6B
<b>Environmentally Friendly</b>	: EU RoHS Compliant, Pb Free

## ■ TYPICAL APPLICATION CIRCUIT

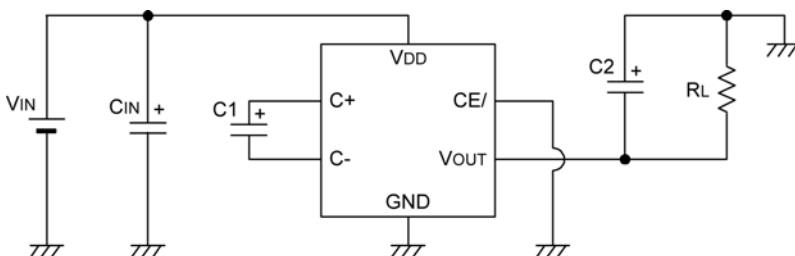

## ■ TYPICAL PERFORMANCE CHARACTERISTICS

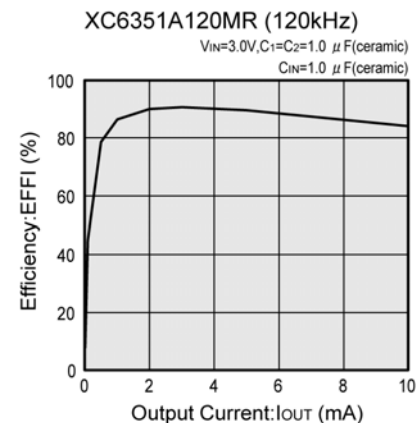

## ■ BLOCK DIAGRAM

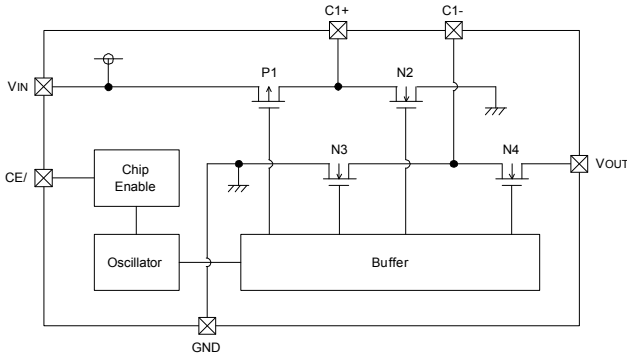

### Note:

- In operation, the following conditions will be repeated alternately:  
P1 & N3 ON: N2 & N4 OFF  
P1 & N3 OFF: N2 & N4 ON
- In standby mode, P1, N3 & N4 will be ON and N2 will be OFF. The output pin VOUT will be connected to GND.

## ■ PRODUCT CLASSIFICATION

### ● Ordering Information

XC6351A ①②③④⑤-⑥<sup>(\*)</sup>

DESIGNATOR	DESCRIPTION	SYMBOL	DESCRIPTION
①②③	Oscillation Frequency	120	120kHz
		035	35kHz (custom)
④⑤-⑥	Packages Taping Type	MR	SOT-26(3,000pcs/Reel)
		MR-G	SOT-26(3,000pcs/Reel)
		DR	USP-6B(3,000pcs/Reel)
		DR-G	USP-6B(3,000pcs/Reel)

(\*) The "-G" suffix indicates that the products are Halogen and Antimony free as well as being fully RoHS compliant.

## ■ PIN CONFIGURATION

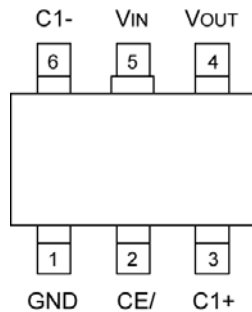

SOT-26  
(TOP VIEW)

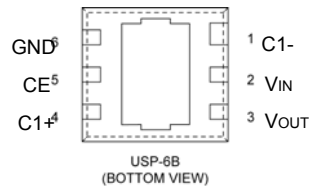

USP-6B  
(BOTTOM VIEW)

\*The dissipation pad for the USP-6B package should be solder-plated in recommended mount pattern and metal masking so as to enhance mounting strength and heat release.

If the pad needs to be connected to other pins, it should be connected to the VIN (No. 2) pin.

## ■ PIN ASSIGNMENT

PIN NUMBER		SYMBOL	FUNCTION
SOT-26	USP-6B		
1	6	GND	Ground
2	5	CE/	Chip Enable (Low Active)
3	4	C1+	External Capacitor +Pin
4	3	VOUT	Reverse Output
5	2	VIN	Power Supply
6	1	C1-	External Capacitor -Pin

## ■ PIN FUNCTIOS ASSIGNMENT

CE/PIN	STATUS
H	Stand-by
L	Active

## ■ ABSOLUTE MAXIMUM RATINGS

Ta = 25°C

PARAMETER	SYMBOL	RATINGS	UNITS	
V <sub>IN</sub> Input Voltage	V <sub>IN</sub>	6.0	V	
V <sub>OUT</sub> Pin Voltage	V <sub>OUT</sub>	-6~0.3	V	
C1+ Pin Voltage	C1+	-0.3~V <sub>IN</sub> + 0.3	V	
C1- Pin Voltage	C1-	V <sub>OUT</sub> - 0.3~0.3	V	
CE/ Pin Voltage	CE/	-0.3~V <sub>IN</sub> + 0.3	V	
V <sub>OUT</sub> Pin Current	I <sub>OUT</sub>	50	mA	
Power Dissipation	SOT-26	P <sub>d</sub>	150	mW
			600 (40mm x 40mm Standard board ) <sup>(*)</sup>	
	100			
	1000 (40mm x 40mm Standard board ) <sup>(*)</sup>			
Operating Temperature Range	T <sub>opr</sub>	-30~+80	°C	
Storage Temperature Range	T <sub>stg</sub>	-40~+125	°C	

Each rating voltage is based on the GND

<sup>(\*)</sup>This is a reference data taken by using the test board. Please see the power dissipation page for the mounting condition.

## ■ ELECTRICAL CHARACTERISTICS

f<sub>osc</sub>=120kHz, Ta=25°C

PARAMETER	SYMBOL	CONDITIONS	MIN.	TYP.	MAX.	UNITS	CIRCUIT
Supply Current	I <sub>DD</sub>		-	310	520	μA	1
Operating Voltage Range	V <sub>IN</sub>	R <sub>L</sub> =5kΩ	1.2	-	5.0	V	2
Oscillation Frequency	f <sub>OSC</sub>		75	120	192	kHz	1
Power Transition Efficiency	EFFI	R <sub>L</sub> =2kΩ	-	90	-	%	2
Voltage Transition Efficiency	VEFFI	R <sub>L</sub> =∞	95	-	-	%	2
Output Impedance	R <sub>OUT</sub>	R <sub>L</sub> =5kΩ	-	45	90	Ω	2
Stand -by Current	I <sub>STB</sub>	CE/=V <sub>IN</sub>	-	-	2.0	μA	3
CE/ 'H' Level Voltage	V <sub>CEH</sub>		0.9	-	-	V	3
CE/ 'L' Level Voltage	V <sub>CEL</sub>		-	-	0.25	V	3

Measuring Conditions: Unless otherwise stated, V<sub>IN</sub> = 5.0V, CE/ = 0V

f<sub>osc</sub>=35kHz, Ta=25°C

PARAMETER	SYMBOL	CONDITIONS	MIN.	TYP.	MAX.	UNITS	CIRCUIT
Supply Current	I <sub>DD</sub>		-	100	170	μA	1
Operating Voltage Range	V <sub>IN</sub>	R <sub>L</sub> =5kΩ	1.2	-	5.0	V	2
Oscillation Frequency	f <sub>OSC</sub>		21	35	56	kHz	1
Power Transition Efficiency	EFFI	R <sub>L</sub> =2kΩ	-	90	-	%	2
Voltage Transition Efficiency	VEFFI	R <sub>L</sub> =∞	95	-	-	%	2
Output Impedance	R <sub>OUT</sub>	R <sub>L</sub> =5kΩ	-	45	90	Ω	2
Stand -by Current	I <sub>STB</sub>	CE/=V <sub>IN</sub>	-	-	2.0	μA	3
CE/ 'H' Level Voltage	V <sub>CEH</sub>		0.9	-	-	V	3
CE/ 'L' Level Voltage	V <sub>CEL</sub>		-	-	0.25	V	3

Measuring Conditions: Unless otherwise stated, V<sub>IN</sub> = 5.0V, CE/ = 0V

## TEST CIRCUITS

Circuit 1

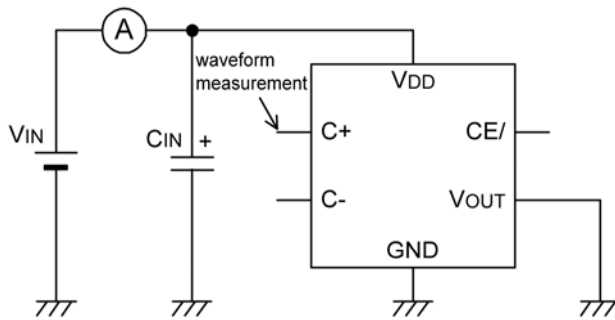

Circuit 2

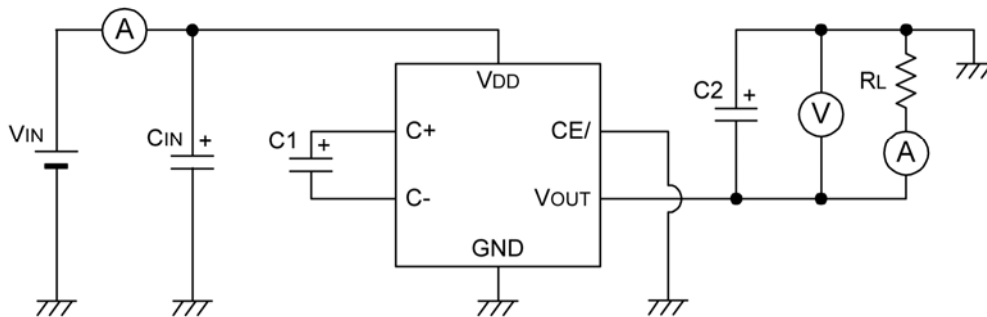

Circuit 3

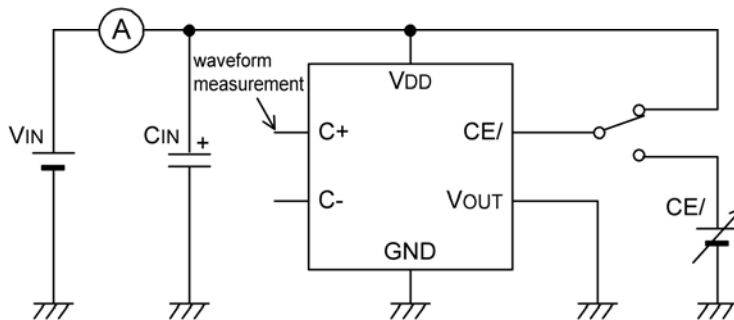

External components:

$C_{IN} = 1 \mu F$  (ceramic capacitor)

$C1 = C2 = 1 \mu F$  (ceramic capacitor)\*

\* With the custom 35kHz frequency,  $C1 = C2 = 3.3 \mu F$

## ■ TYPICAL APPLICATION CIRCUIT

### ● Standard Circuit

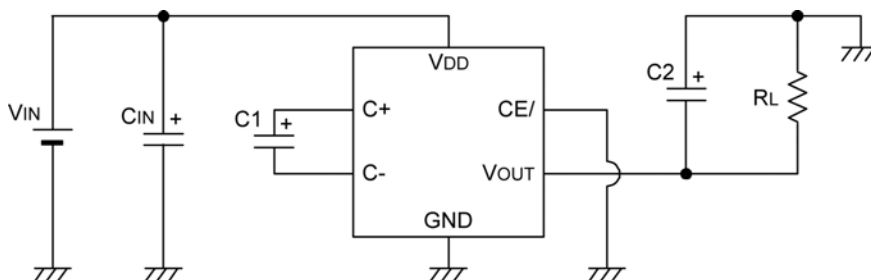

External components:

$C_{IN} = 1 \mu F$  (ceramic capacitor)

$C1 = C2 = 1 \mu F$  (ceramic capacitor)\*

\* With the custom 35kHz frequency,  $C1 = C2 = 3.3 \mu F$

## ■ NOTES ON USE

1. Please use the IC & external components: within the specified electrical characteristics range and ensure that absolute maximum ratings are not exceeded.
2. For  $C1$  &  $C2$ , please use a capacitor with as small an ESR value as possible.
3. In order to reduce impedance between the IC's input pin and the power supply, we recommend that a capacitor ( $C_{IN}$ ) be connected to the input side.
4. If an external power supply is applied to the output pin in order to have  $V_{OUT}$  connected to GND during standby, large current flows through the IC are a possibility. Further, do not use a capacitor at  $C2$  that has a large capacitance value.

## TYPICAL PERFORMANCE CHARACTERISTICS

### (1) Output Voltage vs. Output Current

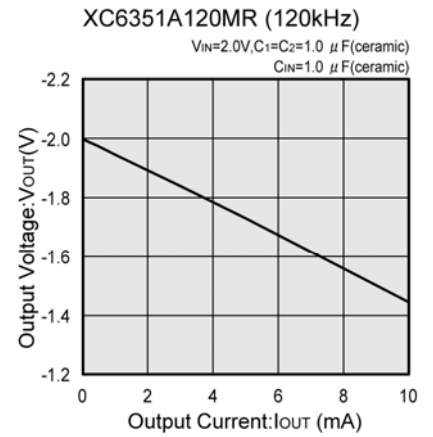
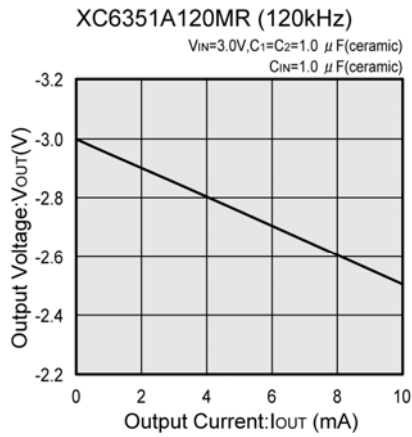
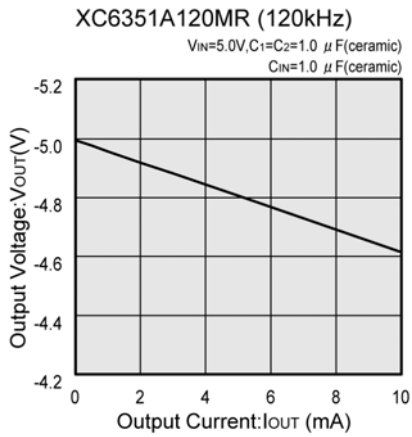

### (2) Efficiency vs. Output Current

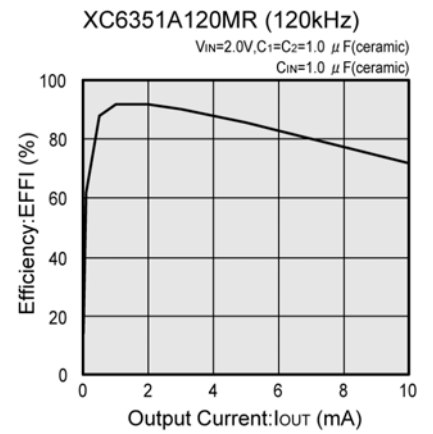
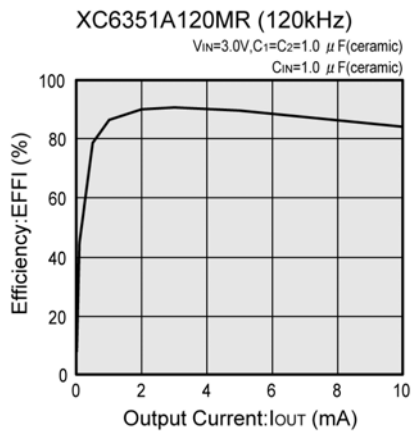
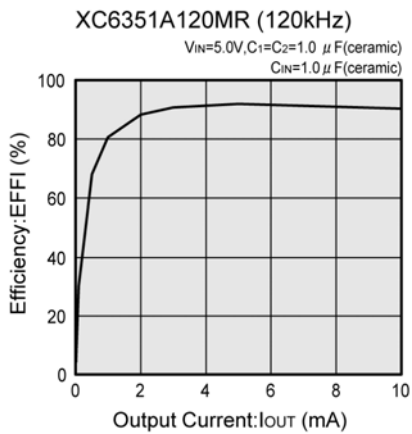

### (3) Oscillation Frequency vs. Ambient Temperature

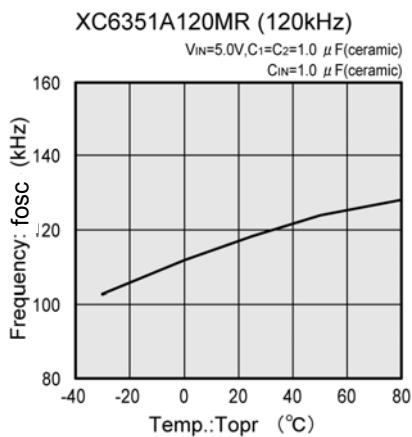

### (4) Oscillation Frequency vs. Input Voltage

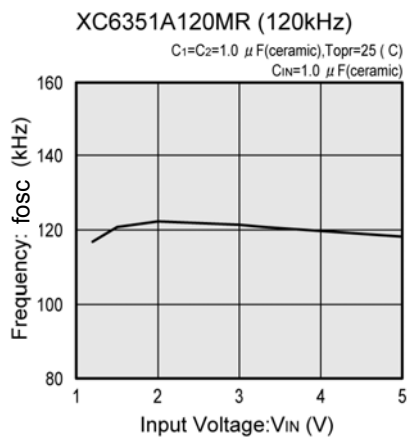

**PACKAGING INFORMATION**

● SOT-26

Unit : mm

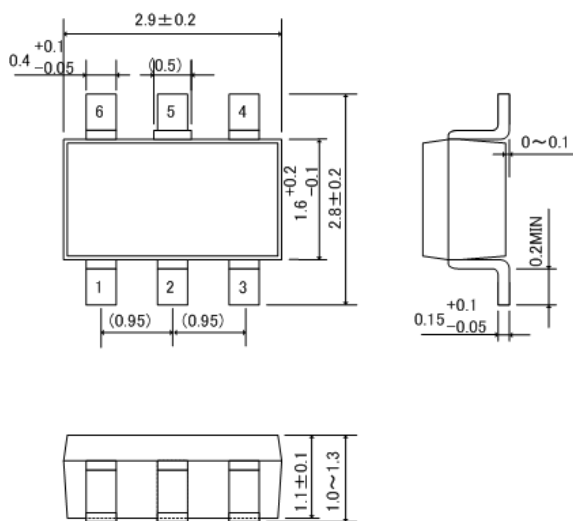

● SOT-26 Reference Pattern Layout

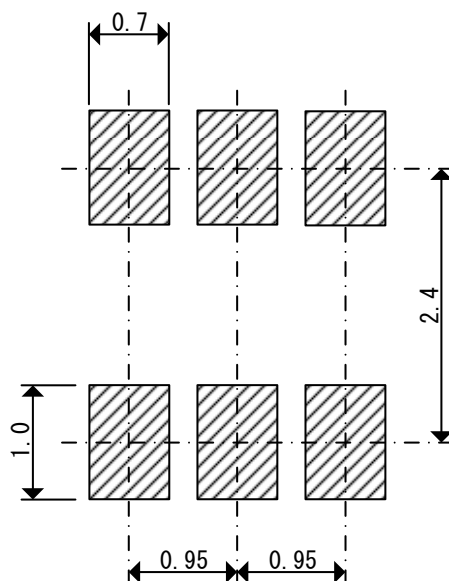

● USP-6B

Unit : mm

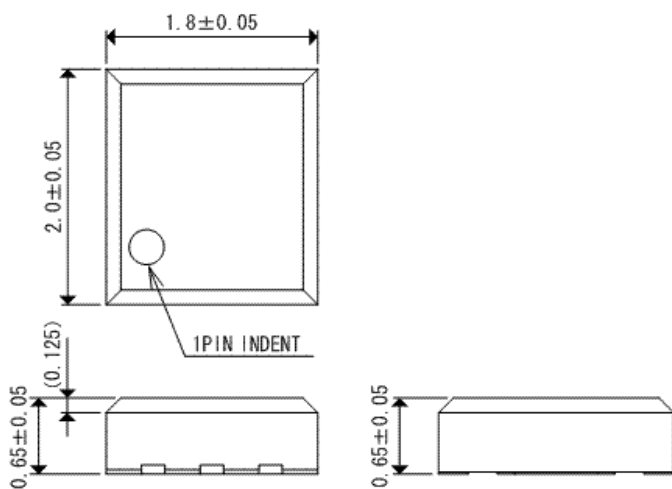

● USP-6B Reference Pattern Layout

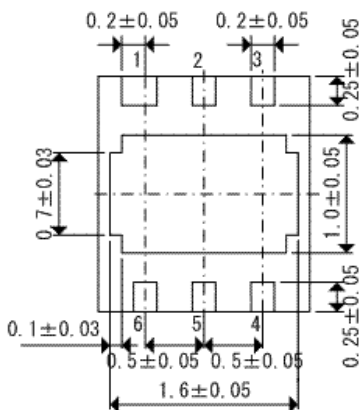
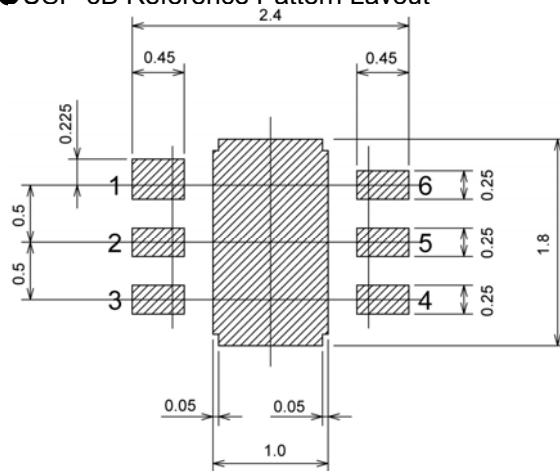

● USP-6B Reference Metal Mask Design

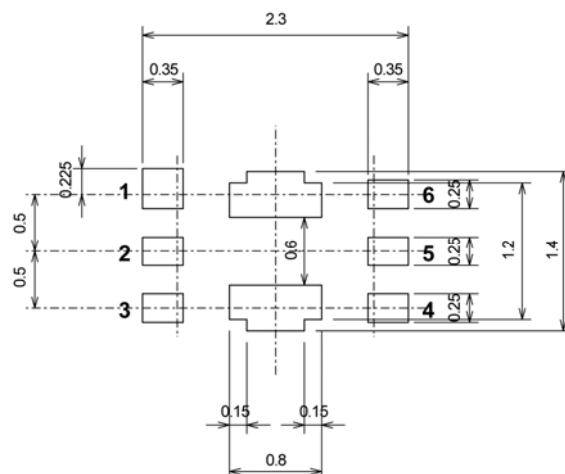

## ● SOT-26 Power Dissipation (40mm x 40mm Standard board)

Power dissipation data for the SOT-26 is shown in this page.

The value of power dissipation varies with the mount board conditions.

Please use this data as the reference data taken in the following condition.

### 1. Measurement Condition

Condition: Mount on a board

Ambient: Natural convection

Soldering: Lead (Pb) free

Board: Dimensions 40 x 40 mm  
(1600 mm<sup>2</sup> in one side)

Copper (Cu) traces occupy 50% of the board area  
in top and back faces

Package heat-sink is tied to the copper traces

Material: Glass Epoxy (FR-4)

Thickness: 1.6mm

Through-hole: 4 x 0.8 Diameter

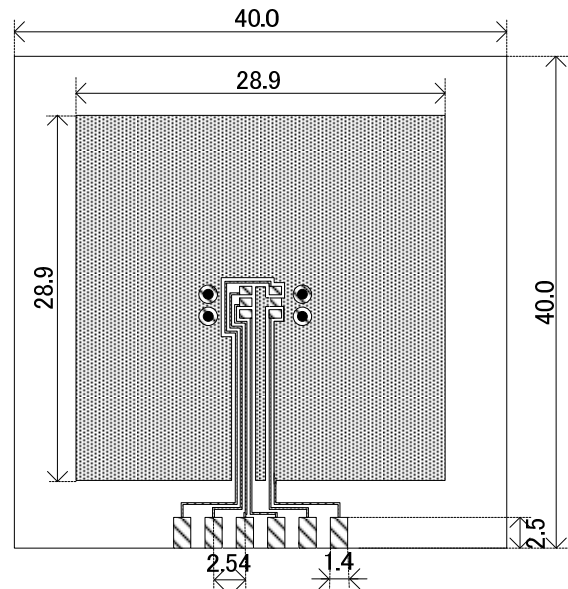

Evaluation Board (Unit: mm)

### 2. Power Dissipation vs. Ambient Temperature

Board Mount ( $T_j$  max = 125°C)

Ambient Temperature (°C)	Power Dissipation Pd (mW)	Thermal Resistance (°C/W)
25	600	166.67
80	270	

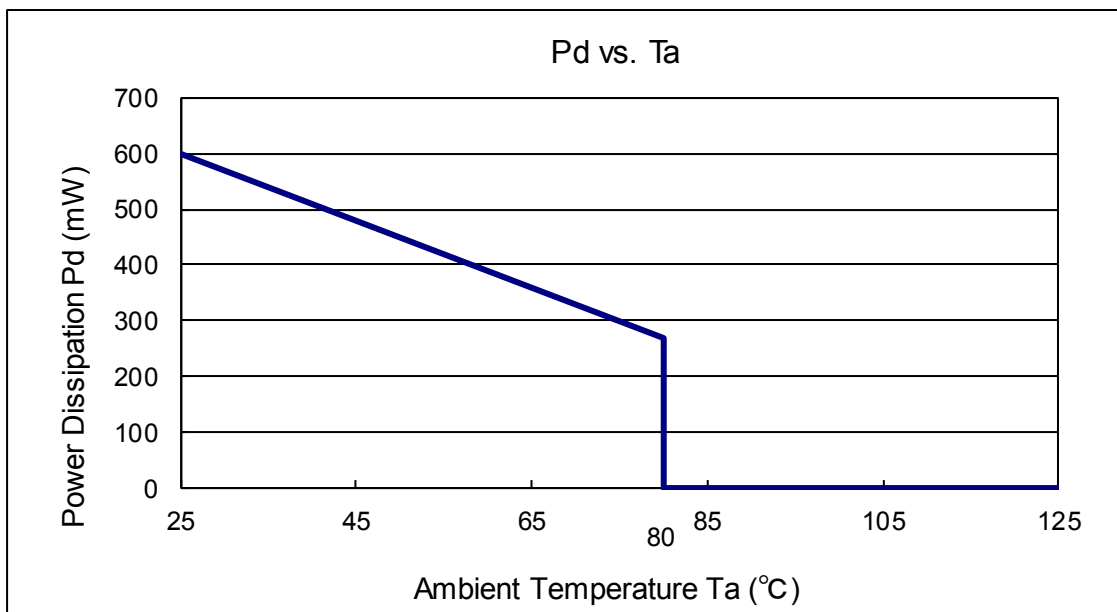



**● USP-6B Power Dissipation (40mm x 40mm Standard board)**

Power dissipation data for the USP-6B is shown in this page.  
The value of power dissipation varies with the mount board conditions.  
Please use this data as the reference data taken in the following condition.

**1. Measurement Condition**

- Condition: Mount on a board
- Ambient: Natural convection
- Soldering: Lead (Pb) free
- Board: Dimensions 40 x 40 mm  
(1600 mm<sup>2</sup> in one side)
- Copper (Cu) traces occupy 50% of the board area in top and back faces
- Package heat-sink is tied to the copper traces
- Material: Glass Epoxy (FR-4)
- Thickness: 1.6mm
- Through-hole: 4 x 0.8 Diameter

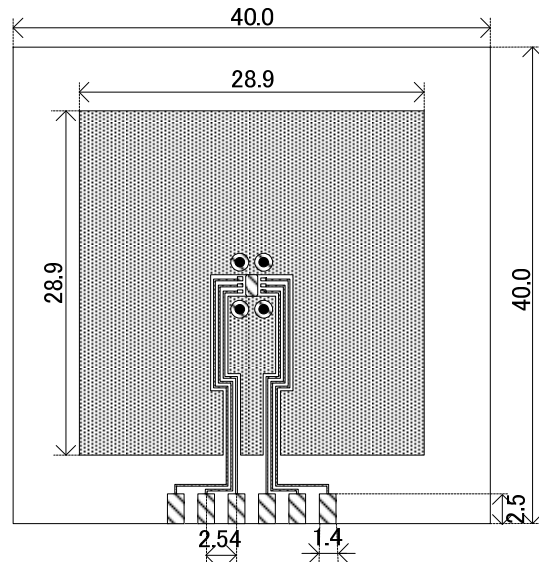

Evaluation Board (Unit: mm)

**2. Power Dissipation vs. Ambient Temperature**

Board Mount ( $T_j \text{ max} = 125^\circ\text{C}$ )

Ambient Temperature ( $^\circ\text{C}$ )	Power Dissipation $P_d$ (mW)	Thermal Resistance ( $^\circ\text{C}/\text{W}$ )
25	1000	100.00
80	450	

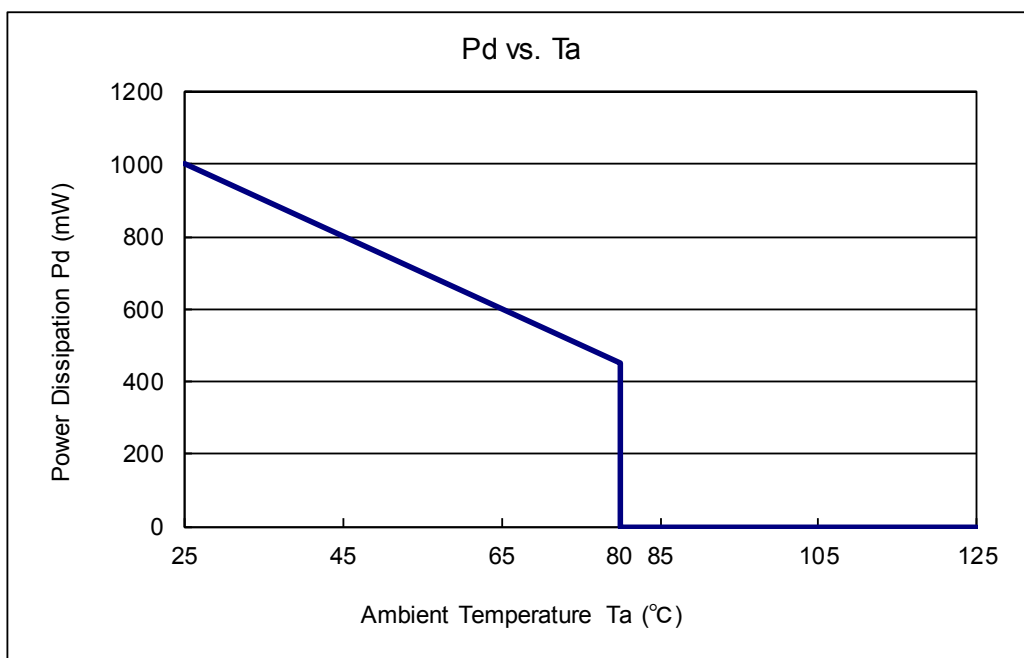

## MARKING RULE

### ● SOT-26

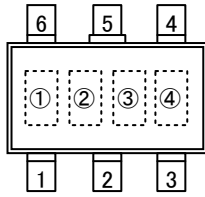

SOT-26  
(TOP VIEW)

① represents product series

MARK		PRODUCT SERIES
A		XC6351AxxxMx-G

②,③ represents oscillation frequency

MARK		OSCILLATION FREQUENCY	PRODUCT SERIES
②	③		
0	3	35kHz	XC6351A035MR-G
1	2	120kHz	XC6351A120MR-G

④ represents production lot number

0 to 9, A to Z repeated (G, I, J, O, Q, W excluded)

### ● USP-6B

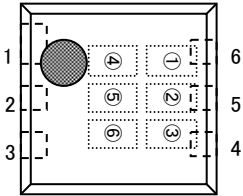

①,②,③ represents product series

MARK			PRODUCT SERIES
①	②	③	
5	1	A	XC6351AxxxDR-G

④,⑤ represents oscillation frequency

MARK		OSCILLATION FREQUENCY	PRODUCT SERIES
④	⑤		
0	3	35kHz	XC6351A035DR-G
1	2	120kHz	XC6351A120DR-G

⑥ represents production lot number

0 to 9, A to Z repeated (G, I, J, O, Q, W excluded)

Note: No character inversion used.

1. The product and product specifications contained herein are subject to change without notice to improve performance characteristics. Consult us, or our representatives before use, to confirm that the information in this datasheet is up to date.
2. The information in this datasheet is intended to illustrate the operation and characteristics of our products. We neither make warranties or representations with respect to the accuracy or completeness of the information contained in this datasheet nor grant any license to any intellectual property rights of ours or any third party concerning with the information in this datasheet.
3. Applicable export control laws and regulations should be complied and the procedures required by such laws and regulations should also be followed, when the product or any information contained in this datasheet is exported.
4. The product is neither intended nor warranted for use in equipment of systems which require extremely high levels of quality and/or reliability and/or a malfunction or failure which may cause loss of human life, bodily injury, serious property damage including but not limited to devices or equipment used in 1) nuclear facilities, 2) aerospace industry, 3) medical facilities, 4) automobile industry and other transportation industry and 5) safety devices and safety equipment to control combustions and explosions. Do not use the product for the above use unless agreed by us in writing in advance.
5. Although we make continuous efforts to improve the quality and reliability of our products; nevertheless Semiconductors are likely to fail with a certain probability. So in order to prevent personal injury and/or property damage resulting from such failure, customers are required to incorporate adequate safety measures in their designs, such as system fail safes, redundancy and fire prevention features.
6. Our products are not designed to be Radiation-resistant.
7. Please use the product listed in this datasheet within the specified ranges.
8. We assume no responsibility for damage or loss due to abnormal use.
9. All rights reserved. No part of this datasheet may be copied or reproduced unless agreed by Torex Semiconductor Ltd in writing in advance.

TOREX SEMICONDUCTOR LTD.

## X-ON Electronics

Largest Supplier of Electrical and Electronic Components

*Click to view similar products for [Switching Voltage Regulators](#) category:*

*Click to view products by [Torex Semiconductor](#) manufacturer:*

Other Similar products are found below :

[FAN53610AUC33X](#) [FAN53611AUC123X](#) [FAN48610BUC33X](#) [FAN48610BUC45X](#) [FAN48617UC50X](#) [R3](#) [430464BB](#) [KE177614](#)  
[FAN53611AUC12X](#) [MAX809TTR](#) [NCV891234MW50R2G](#) [NCP81103MNTXG](#) [NCP81203PMNTXG](#) [NCP81208MNTXG](#)  
[NCP81109GMNTXG](#) [SCY1751FCCT1G](#) [NCP81109JMNTXG](#) [AP3409ADNTR-G1](#) [NCP81241MNTXG](#) [LTM8064IY](#) [LT8315EFE#TRPBF](#)  
[LTM4664EY#PBF](#) [LTM4668AIY#PBF](#) [NCV1077CSTBT3G](#) [XCL207A123CR-G](#) [MPM54304GMN-0002](#) [MPM54304GMN-0004](#)  
[MPM54304GMN-0003](#) [AP62300Z6-7](#) [MP8757GL-P](#) [MIC23356YFT-TR](#) [LD8116CGL](#) [HG2269M/TR](#) [OB2269](#) [XD3526](#) [U6215A](#) [U6215B](#)  
[U6620S](#) [LTC3412IFE](#) [LT1425IS](#) [MAX25203BATJA/VY+](#) [MAX77874CEWM+](#) [XC9236D08CER-G](#) [MP3416GJ-P](#) [MP5461GC-Z](#)  
[MPQ4415AGQB-Z](#) [MPQ4590GS-Z](#) [MAX38640BENT18+T](#) [MAX77511AEWB+](#) [MAX20406AFOD/VY+](#)