

BLOCK DIAGRAMS

Type A

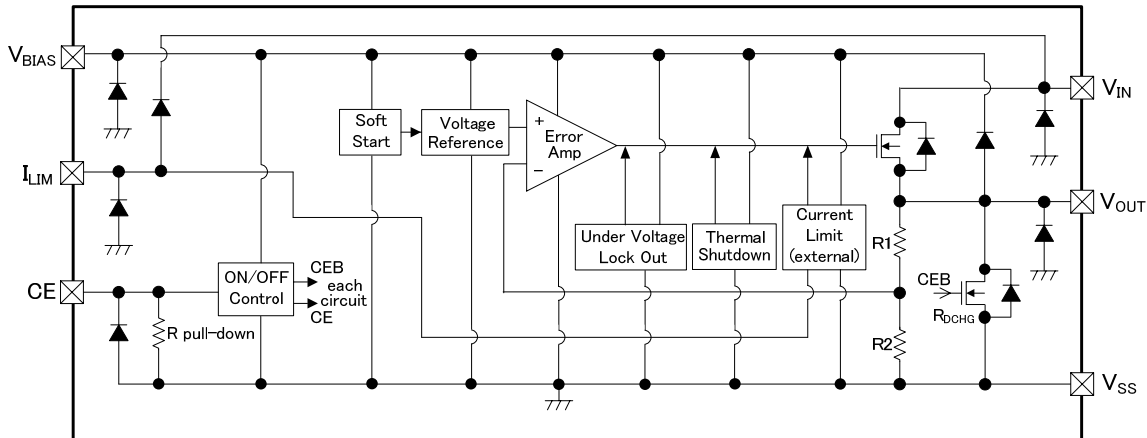

Type B

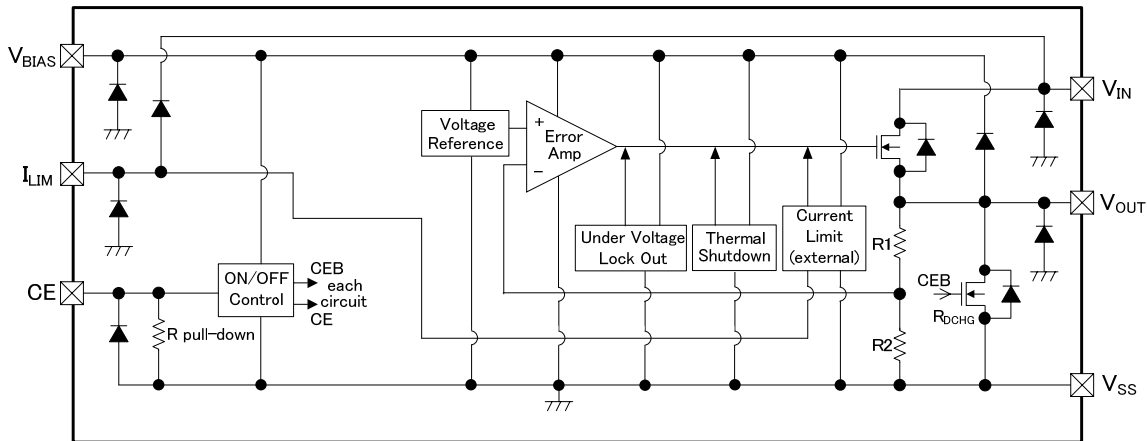

PRODUCT CLASSIFICATION

Ordering Information

XC6604①②③④⑤⑥⑦

DESIGNATOR	ITEM	SYMBOL	DESCRIPTION
①	Type	A	Refer to Selection Guide
		B	
②③	Output Voltage	05~18	e.g. 1.2V → ②=1, ③=2
④	Output Voltage Accuracy	1	±0.015V ($V_{OUT} < 1.2V$), ±0.020V ($V_{OUT} \geq 1.2V$)
⑤⑥⑦ (*1)	Packages (Order Unit)	ER-G	USP-6C (3,000/Reel)
		MR-G	SOT-26W (3,000/Reel)

(*1) The "G" suffix denotes Halogen and Antimony free as well as being fully EU RoHS compliant.

Selection Guide

TYPE	SOFT-START	CURRENT LIMITER	THERMAL SHUTDOWN	UVLO	CE PULL-DOWN RESISTOR	C _L AUTO DISCHARGE
A	Yes	Adjustable	Yes	Yes	Yes	Yes
B	No	Adjustable	Yes	Yes	Yes	Yes

■ PIN CONFIGURATION

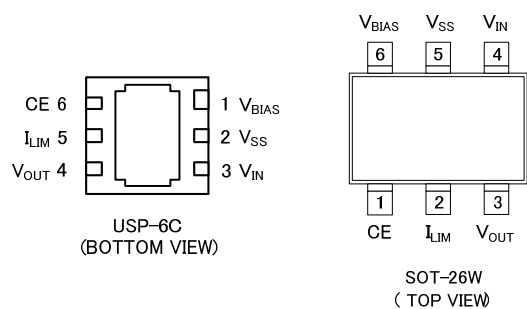

*The dissipation pad for the USP-6C package should be solder-plated in recommended mount pattern and metal masking so as to enhance mounting strength and heat release. If the pad needs to be connected to other pins, it should be connected to the V_{SS} (No. 2) pin.

■ PIN ASSIGNMENT

PIN NUMBER		PIN NAME	FUNCTIONS
USP-6C	SOT-26W		
1	6	V_{BIAS}	Power Supply Input
2	5	V_{SS}	Ground
3	4	V_{IN}	Driver Transistor Input
4	3	V_{OUT}	Output
5	2	I_{LIM}	Current Limit Resistance Connection
6	1	CE	ON/OFF Control

■ FUNCTION CHART

PIN NAME	SIGNAL	STATUS
CE	L	Stand-by
	H	Active
	OPEN	Stand-by

■ ABSOLUTE MAXIMUM RATINGS

Ta=25°C

PARAMETER		SYMBOL	RATINGS	UNITS
Bias Voltage		V _{BIAS}	-0.3~+6.5	V
Input Voltage		V _{IN}	-0.3~+6.5	V
Output Current		I _{OUT}	1.65 ⁽¹⁾	A
Output Voltage ⁽²⁾		V _{OUT}	-0.3~V _{BIAS} +0.3 or +6.5	V
			-0.3~V _{IN} +0.3 or +6.5	
CE Input Voltage		V _{CE}	-0.3~+6.5	V
I _{LIM} Pin Voltage ⁽³⁾		I _{LIM}	-0.3~V _{IN} +0.3 or +6.5	V
Power Dissipation	USP-6C	Pd	120	mW
			1000 (PCB mounted) ⁽⁴⁾	
	SOT-26W		250	
			600 (PCB mounted) ⁽⁴⁾	
Operating Ambient Temperature		Topr	-40~+85	°C
Storage Temperature		Tstg	-55~+125	°C

* All voltages are described based on the V_{SS} pin.

⁽¹⁾ $I_{OUT} \leq Pd / (V_{IN} - V_{OUT})$

⁽²⁾ The maximum value should be either V_{BIAS}+0.3, V_{IN}+0.3 or +6.5 in the lowest.

⁽³⁾ The maximum value should be either V_{IN}+0.3 or +6.5 in the lowest.

⁽⁴⁾ The power dissipation measured with the test board condition is listed as reference data.

Please refer to page 26~27 for details.

ELECTRICAL CHARACTERISTICS

Ta=25°C

PARAMETER	SYMBOL	CONDITIONS	MIN.	TYP.	MAX.	UNITS	CIRCUIT	
Bias Voltage	V _{BIAS}		2.5	-	6.0	V	①	
Input Voltage	V _{IN}		0.5	-	3.0	V	①	
Output Voltage	V _{OUT(E)} ⁽¹⁾	I _{OUT} =100mA	V _{OUT(T)} <1.2V	-0.015	V _{OUT(T)} ⁽²⁾	+0.015	V	①
			V _{OUT(T)} ≥1.2V	-0.020		+0.020		
Maximum Output Current ⁽³⁾	I _{OUTMAX}	V _{OUT(T)} <1.2V, V _{BIAS} =V _{CE} =2.5V	1.0	-	-	A	①	
		V _{OUT(T)} ≥1.2V, V _{BIAS} =V _{CE} =V _{OUT(T)} +1.3V						
Load Regulation	ΔV _{OUT}	1mA≤I _{OUT} ≤1A	-	37	68	mV	①	
Dropout Voltage	V _{dif} ⁽⁴⁾	I _{OUT} =1A	-	E-1 ⁽⁵⁾		mV	①	
Supply Current 1 ⁽⁶⁾	I _{BIAS}	I _{OUT} =0A	76	100	143	μA	②	
Supply Current 2	I _{IN}	I _{OUT} =0A	V _{OUT(T)} <1.2V	0.1	-	8.7	μA	②
			V _{OUT(T)} ≥1.2V	3.9	-	14.2		
Stand-by Current 1	I _{BIAS_STB}	V _{BIAS} =6.0V, V _{IN} =3.0V, V _{CE} =V _{SS}	-	0.01	0.10	μA	②	
Stand-by Current 2	I _{IN_STB}	V _{BIAS} =6.0V, V _{IN} =3.0V, V _{CE} =V _{SS}	-	0.01	0.15	μA	②	
Bias Line Regulation	ΔV _{OUT} / (ΔV _{BIAS} ·V _{OUT})	V _{OUT(T)} <1.2V, V _{CE} =V _{BIAS} , 2.5V≤V _{BIAS} ≤6.0V	-	0.01	0.10	%V	①	
		V _{OUT(T)} ≥1.2V, V _{CE} =V _{BIAS} , V _{OUT(T)} +1.3V≤V _{BIAS} ≤6.0V						
Input Line Regulation	ΔV _{OUT} / (ΔV _{IN} ·V _{OUT})	V _{OUT(T)} +0.1V≤V _{IN} ≤3.0V	-	0.01	0.10	%V	①	
Bias UVLO Voltage	V _{BIAS_UVL0D}		V _{SS}	-	1.28	V	①	
Bias UVLO Release Voltage	V _{BIAS_UVLOR}		2.5	-	6.0	V	①	
Input UVLO Voltage	V _{IN_UVL0D}		V _{SS}	-	0.23	V	①	
Input UVLO Release Voltage	V _{IN_UVLOR}		0.5	-	3.0	V	①	
Output Voltage Temperature Characteristics	ΔV _{OUT} / (ΔT _{opr} ·V _{OUT})	I _{OUT} =100mA -40°C≤T _{opr} ≤85°C	-	±30	-	ppm/°C	①	
Bias Ripple Rejection Ratio	V _{BIAS_PSR}	V _{BIAS} =V _{CE} =3.6V _{DC} +0.2V _{p-pAC} I _{OUT} =100mA, f=1kHz, C _{BIAS} =OPEN	-	60	-	dB	③	
Input Ripple Rejection Ratio	V _{IN_PSR}	V _{IN} =V _{OUT(T)} +0.3V _{DC} +0.2V _{p-pAC} I _{OUT} =100mA, f=1kHz, C _{IN} =OPEN	-	75	-	dB	③	
Current Limit ⁽³⁾	I _{LIM}	V _{OUT} ={V _{OUT@I_{OUT}=1A} }×0.95	1.0	1.3	-	A	①	
Adjustable Current Limit Accuracy ⁽⁸⁾	I _{LIM_ADJ}	-	(-35)	-	(35)	%	①	
Short - Circuit Current	I _{SHORT}	V _{OUT} =V _{SS}	-	90	-	mA	①	
Thermal Shutdown Detect Temperature	T _{TSD}	Junction Temperature	-	150	-	°C	①	
Thermal Shutdown Release Temperature	T _{TSR}	Junction Temperature	-	125	-	°C	①	
Thermal Shutdown Hysteresis Width	T _{TSD} -T _{TSR}	Junction Temperature	-	25	-	°C	①	
C _L Auto-Discharge Resistance	R _{DCHG}	V _{CE} =V _{SS} , V _{OUT} =V _{OUT(T)}	130	190	255	Ω	①	
CE "H" Level Voltage	V _{CEH}		0.65	-	6.00	V	④	
CE "L" Level Voltage	V _{CEL}		V _{SS}	-	0.41	V	④	
CE "H" Level Current	I _{CEH}	V _{BIAS} =V _{CE} =6.0V	3.2	6.0	10.6	μA	④	
CE "L" Level Current	I _{CEL}	V _{BIAS} =6.0V, V _{CE} =V _{SS}	-0.1	-	0.1	μA	④	
Soft-Start Time ⁽⁷⁾ (Type A)	t _{SS}	V _{CE} =0V→3.6V, tr=5μs	225	430	600	μs	⑤	
Output Rise Time ⁽⁷⁾ (Type B)	t _{ON}	V _{CE} =0V→3.6V, tr=5μs	-	-	110	μs	⑤	
Inrush Current (Type A)	I _{RUSH}	C _L =2.2μF	V _{OUT(T)} ≤1.2V	-	-	70	mA	⑤
			V _{OUT(T)} >1.2V	-	-	85		
		C _L =10μF	V _{OUT(T)} ≤1.2V	-	-	155		
			V _{OUT(T)} >1.2V	-	-	215		

NOTE:

Unless otherwise stated, V_{BIAS}=V_{CE}=3.6V, V_{IN}=V_{OUT(T)}+0.3V, I_{OUT}=1mA, C_{BIAS}=C_{IN}=1.0μF, C_L=2.2μF, I_{LIM} Pin=V_{SS}

(1) V_{OUT(E)} = Effective output voltage

(2) V_{OUT(T)} = Nominal output voltage

(3) Mount conditions affect heat dissipation. Maximum output current is not guaranteed when TSD starts to operate earlier.

(4) V_{dif}={V_{IN1}-V_{OUT1}}

V_{IN1} is an input voltage when V_{OUT1} appears at the output during decreasing input voltage gradually.

V_{OUT1} is a voltage equal to 98% of the output voltage where V_{BIAS}=V_{CE}=3.6 and V_{IN}=V_{OUT(T)}+0.3V at I_{OUT}=1A is input to the V_{IN} pin.

(5) Please refer to the table E-1 named DROPOUT VOLTAGE CHART

(6) Supply current 1 (I_{BIAS}) may be fluctuated because that some bias current flows into the output.

(7) A time between the CE input goes over the CE H threshold and the output reaches V_{OUT(E)}×0.9V.

(8) Design value

■ ELECTRICAL CHARACTERISTICS (Continued)

● Dropout Voltage Chart

NOMINAL OUTPUT VOLTAGE	E-1														
	DROPOUT VOLTAGE (mV)														
	V _{BIAS} =3.0V			V _{BIAS} =3.3V			V _{BIAS} =3.6V			V _{BIAS} =4.2V			V _{BIAS} =5.0V		
	V _{GS} (V)	V _{dif} (mV)		V _{GS} (V)	V _{dif} (mV)		V _{GS} (V)	V _{dif} (mV)		V _{GS} (V)	V _{dif} (mV)		V _{GS} (V)	V _{dif} (mV)	
TYP.		MAX.	TYP.		MAX.	TYP.		MAX.	TYP.		MAX.	TYP.		MAX.	
V _{OUT(T)}															
0.5	2.5	152	218	2.8	146	213	3.1	146	213	3.7	140	208	4.5	137	206
0.6	2.4	155	223	2.7			3.0			3.6					
0.7	2.3			2.6			2.9			3.5					
0.8	2.2	158	228	2.5			152			218			2.8		
0.9	2.1	162	233	2.4	155	223	2.7	3.3	4.1						
1.0	2.0	165	238	2.3			2.6	3.2	4.0						
1.1	1.9	167	243	2.2	158	228	2.5	152	218	3.1	3.9				
1.2	1.8	169	253	2.1	162	233	2.4	155	223	3.0	146	213	3.8	140	208
1.3	1.7	179	268	2.0	165	238	2.3			2.9			3.7		
1.4	1.6	189	283	1.9	167	243	2.2	158	228	2.8			3.6		
1.5	1.5	202	303	1.8	169	253	2.1	162	233	2.7			3.5		
1.6	1.4	213	328	1.7	179	268	2.0	165	238	2.6	3.4				
1.7	1.3	225	373	1.6	189	283	1.9	167	243	2.5	152	218	3.3		
1.8	1.2	255	423	1.5	202	303	1.8	169	253	2.4	155	223	3.2	146	213

* Dropout voltage is defined as the $V_{GS}(=V_{BIAS}-V_{OUT(E)})$ of the driver transistor.

TEST CIRCUITS

CIRCUIT①

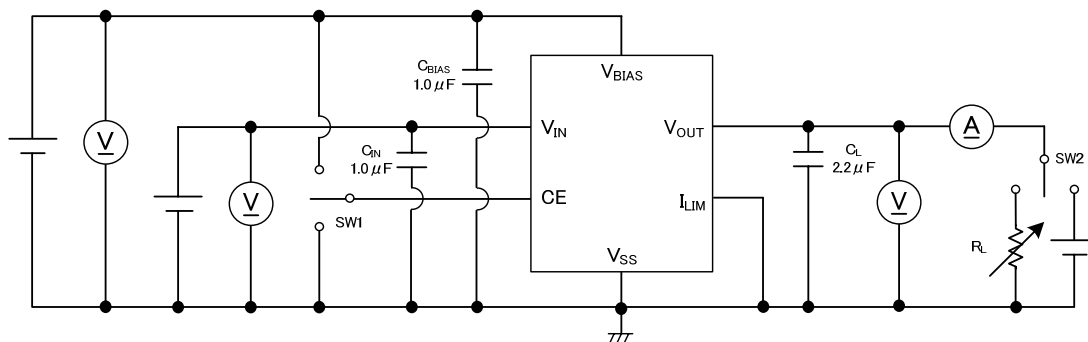

CIRCUIT②

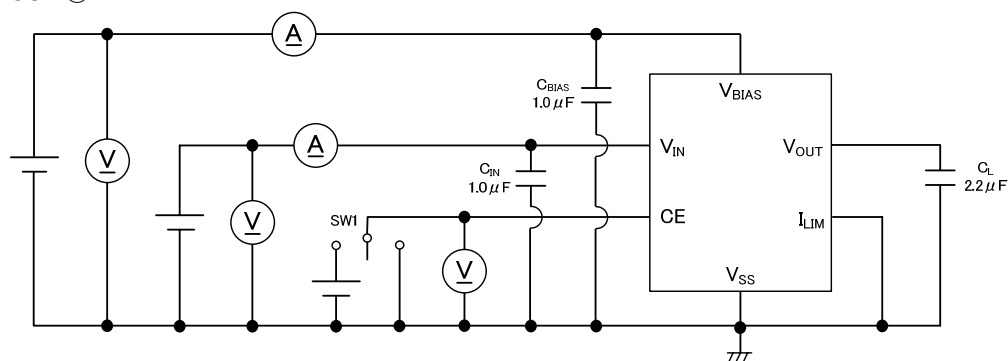

CIRCUIT③

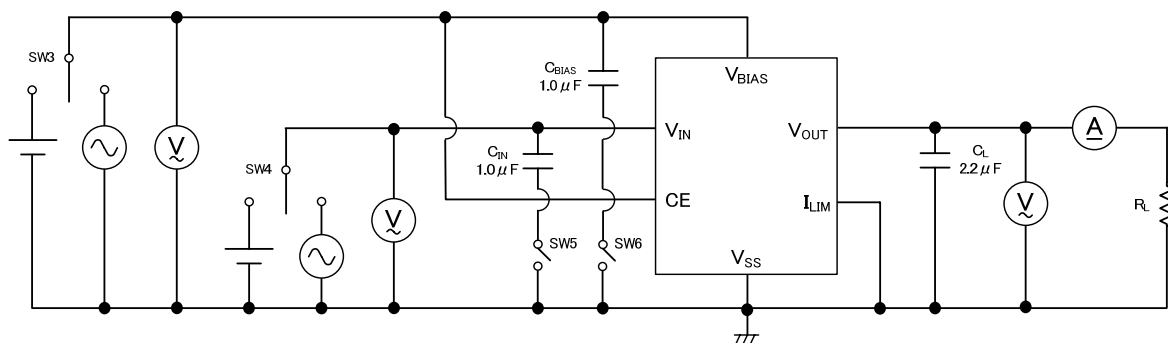

CIRCUIT④

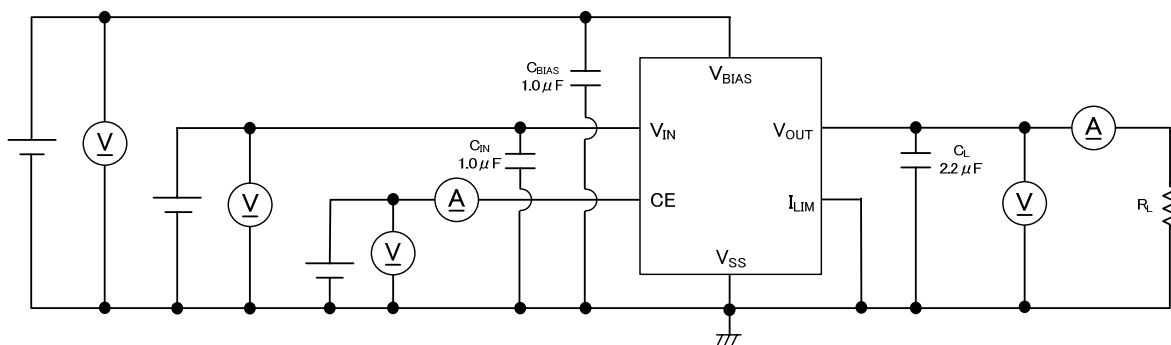

TEST CIRCUITS (Continued)

CIRCUIT⑤

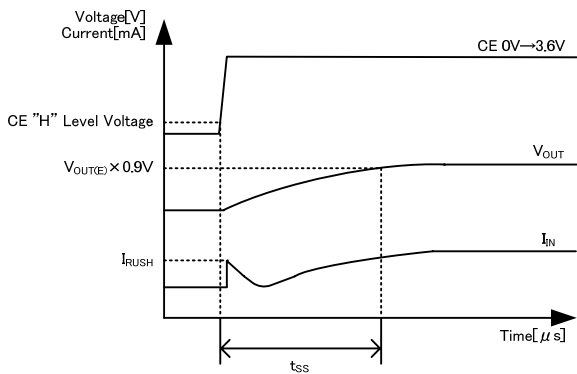
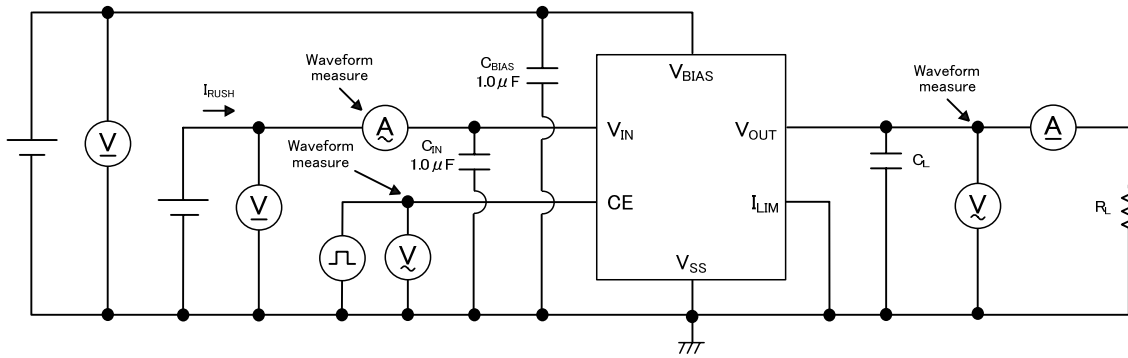

XC6604 Series, Type A

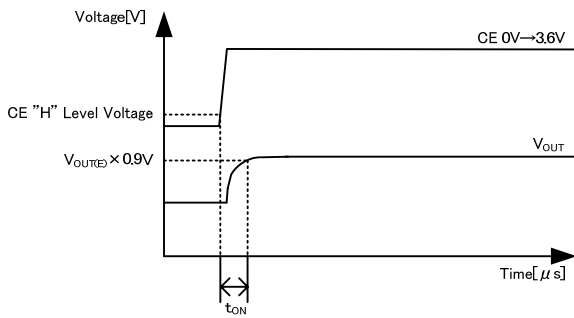

XC6604 Series, Type B

OPERATIONAL DESCRIPTION

The voltage divided by resistors R1 and R2 is compared with the internal reference voltage by the error amplifier. The V_{OUT} pin is then driven by the subsequent output signal. The output voltage at the V_{OUT} pin is controlled and stabilized by a system of negative feedback.

V_{BIAS} pin is power supply pin for output voltage control circuit, protection circuit and CE circuit. Also, the V_{BIAS} pin supplies some current as output current. V_{IN} pin is connected to a driver transistor and provides output current.

In order to obtain high efficient output current through low on-resistance, please take enough $V_{GS} (=V_{BIAS} - V_{OUT(E)})$ of the driver transistor.

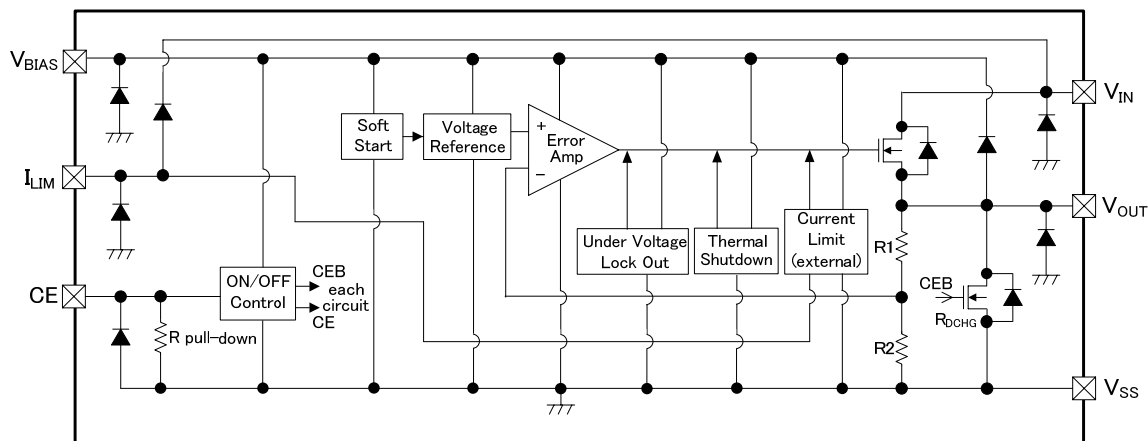

Figure1: XC6604 Series, Type A

<Current Limiter, Short-Circuit Protection>

The XC6604 series includes a combination of a fixed current limiter circuit and a foldback short-circuit protection. When the output current reaches the current limit, the output voltage drops and this operation makes the output current foldback to be decreased.

The current limit can be set freely with connecting a resistor to the I_{LIM} pin.

Please note about the foldback circuit characteristics below;

- Output voltage may not rise when the output voltage is lower than 0V at the IC operation start.
- Current over the foldback current limit will not flow at the IC operation start.
- Please use type A (with soft-start time) to prevent from inrush current, because the circuit may not response to a drastic current change such as the inrush current.

When the I_{LIM} pin is left open, driver transistor will be forced off.

Current Limit is calculated by the following formulas.

$$I_{LIM} = V_{OUT(T)} / (R_{LIM1} + R_{LIM2}) \times 79645.7 \text{ [A]}$$

$$R_{LIM1} = V_{OUT(T)} / (16.3 \times 10^{-6}) \text{ [\Omega]}$$

I_{LIM} : Current Limit

$V_{OUT(T)}$: Nominal Output Voltage

R_{LIM1} : Internal Current Limit Resistance

R_{LIM2} : External Current Limit Resistance

Figure 2: XC6604 Series, Range of adjustable current limit

OUTPUT VOLTAGE RANGE	ADJUSTABLE CURRENT LIMIT
$V_{OUT(T)}$	I_{LIM}
0.5V~1.8V	0.5A~1.3A

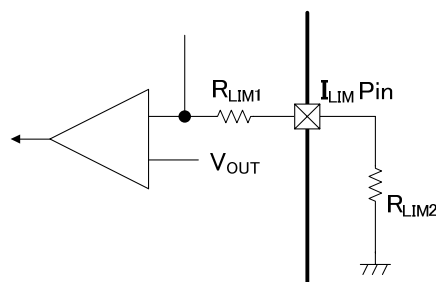

XC6604 Series, R_{LIM2} Connecting

OPERATIONAL DESCRIPTION (Continued)

<Soft-Start Function>

With the XC6604 (Type A), the inrush current (I_{RUSH}) from V_{IN} to V_{OUT} for charging C_L at start-up can be reduced and makes the V_{IN} stable. As for the XC6604, the soft-start time in the type A is optimized internally. On the other hand, the type B of the XC6604 does not have the soft-start time function.

<Thermal Shutdown Circuit (TSD) >

When the junction temperature of the built-in driver transistor reaches the temperature limit, the thermal shutdown circuit operates and the driver transistor will be set to OFF. The IC resumes its operation when the thermal shutdown function is released and the IC's operation is automatically restored because the junction temperature drops to the level of the thermal shutdown release temperature.

<Under Voltage Lock Out (UVLO) >

When the V_{BIAS} pin and V_{IN} pin voltage drops, the output driver transistor is set to OFF by UVLO function to prevent false output caused by unstable operation of the internal circuitry. When the V_{BIAS} pin voltage and the V_{IN} pin voltage rises at release voltage, the UVLO function is released. The driver transistor is turned ON and start to operate voltage regulation.

<CE Pin>

The XC6604 internal circuitry can be shutdown via the signal to the CE pin. In shutdown mode with CE low level voltage, the V_{OUT} pin will be pulled down to the V_{SS} level via C_L discharge resistance (R_{DCHG}) placed in parallel to R1 and R2.

The CE pin has pull-down circuitry so that CE input current flows during IC operation. If the CE pin voltage is taken from V_{BIAS} pin or V_{SS} pin then logic is fixed and the IC will operate normally. However, supply current may increase as a result of through current in the IC's internal circuitry when medium voltage is input.

< C_L High Speed Auto-Discharge>

XC6604 series can quickly discharge the electric charge at the output capacitor (C_L) via the internal transistor located between the V_{OUT} pin and the V_{SS} pin when a low signal to the CE pin which enables a whole IC circuit put into OFF state. When the IC is disabled, electric charge at the output capacitor (C_L) is quickly discharged so that it could avoid malfunction. Discharge time of the output capacitor (C_L) is set by the C_L auto-discharge resistance (R_{DCHG}) and the output capacitor (C_L). By setting time constant of a C_L auto-discharge resistance value (R_{DCHG}) and an output capacitor value (C_L) as τ ($\tau = C_L \times R_{DCHG}$), the output voltage after discharge via the internal transistor is calculated by the following formula. Please also note R_{DCHG} is depended on V_{BIAS} . When V_{BIAS} is larger, R_{DCHG} is smaller.

$$V = V_{OUT(E)} \times e^{-t/\tau} \text{ or } t = \tau \ln (V_{OUT(E)} / V)$$

V: Output voltage during discharge

$V_{OUT(E)}$: Initial Output voltage

t: Discharge time

τ : $C_L \times R_{DCHG}$

<Low ESR Capacitor>

With the XC6604 series, a stable output voltage is achievable even if used with low ESR capacitors, as a phase compensation circuit is built-in. The output capacitor (C_L) should be connected as close to V_{OUT} pin and V_{SS} pin to obtain stable phase compensation. Values required for the phase compensation are as the table below.

For a stable power input, please connect a bias capacitor (C_{BIAS}) between the V_{BIAS} pin and the V_{SS} pin. Also, please connect an input capacitor (C_{IN}) between the V_{IN} pin and the V_{SS} pin. In order to ensure the stable phase compensation while avoiding run-out of values, please use the capacitor (C_{BIAS} , C_{IN} and C_L) which does not depend on bias or temperature too much. The table below (Figure 3) shows recommended values of C_{BIAS} , C_{IN} and C_L .

Figure 3: Recommended Values of C_{BIAS} , C_{IN} and C_L (MIN.)

OUTPUT VOLTAGE RANGE	BIAS CAPACITOR	INPUT CAPACITOR	OUTPUT CAPACITOR
$V_{OUT(T)}$	C_{BIAS}	C_{IN}	C_L
0.5V~1.8V	1.0 μ F	1.0 μ F	2.2 μ F

■ NOTES ON USE

1. For temporary, transitional voltage drop or voltage rising phenomenon, the IC is liable to malfunction should the ratings be exceeded.
2. Where wiring impedance is high, operations may become unstable due to noise and/or phase lag depending on output current. Please keep the resistance low for the V_{BIAS} , V_{IN} and V_{SS} wiring in particular.
3. Please wire the C_{BIAS} , C_{IN} and C_L as close to the IC as possible.
4. Capacitances of these capacitors (C_{BIAS} , C_{IN} , C_L) are decreased by the influences of bias voltage and ambient temperature. Care shall be taken for capacitor selection to ensure stability of phase compensation from the point of ESR influence.
5. When it is used in a quite small input / output dropout voltage, output may go into unstable operation. Please test it thoroughly before using it in production.
6. Torex places an importance on improving our products and their reliability.
We request that users incorporate fail-safe designs and post-aging protection treatment when using Torex products in their systems.

TYPICAL PERFORMANCE CHARACTERISTICS

* Unless otherwise stated, $V_{BIAS}=V_{CE}=3.6V$, $V_{IN}=V_{OUT(T)}+0.3V$, $I_{OUT}=1mA$, $I_{LIM} \text{ Pin} = V_{SS}$, $C_{BIAS}=C_{IN}=1.0 \mu F$, $C_L=2.2 \mu F$, $T_a=25^\circ C$

(1) Output Voltage vs. Output Current

XC6604x051MR-G

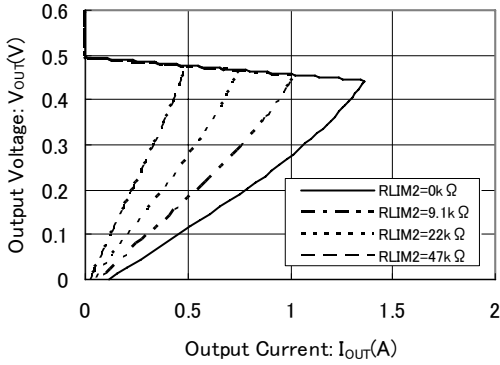

XC6604x051MR-G

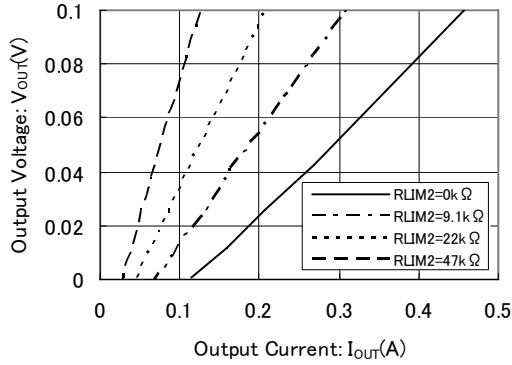

XC6604x121MR-G

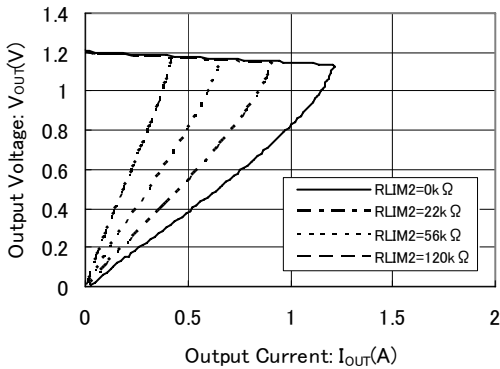

XC6604x121MR-G

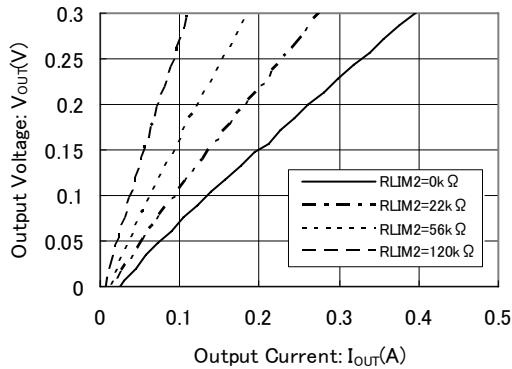

XC6604x181MR-G

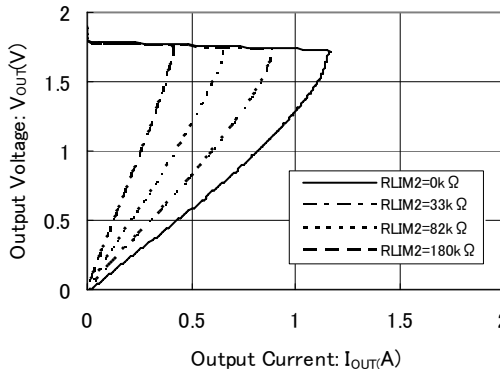

XC6604x181MR-G

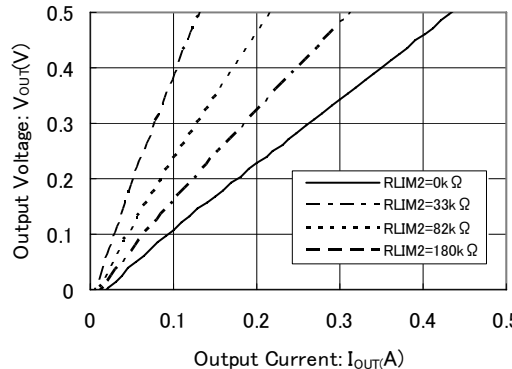

* Mount conditions affect heat dissipation. Thermal shutdown may start to operate before reaching the current limit.

* If start-up current is required over the current limit, IC operation will not start. Please use the current within the range of use.

■ TYPICAL PERFORMANCE CHARACTERISTICS (Continued)

* Unless otherwise stated, $V_{BIAS}=V_{CE}=3.6V$, $V_{IN}=V_{OUT(T)}+0.3V$, $I_{OUT}=1mA$, $I_{LIM} Pin=V_{SS}$, $C_{BIAS}=C_{IN}=1.0\mu F$, $C_L=2.2\mu F$, $T_a=25^\circ C$

(2) Limit Current vs. Adjustable Resistance

XC6604xxx1xR-G

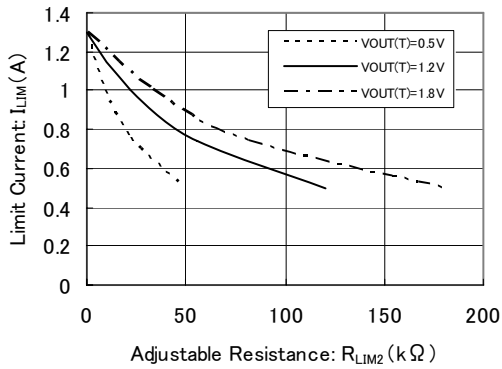

(3) Output Voltage vs. Bias Voltage

XC6604x051xR-G

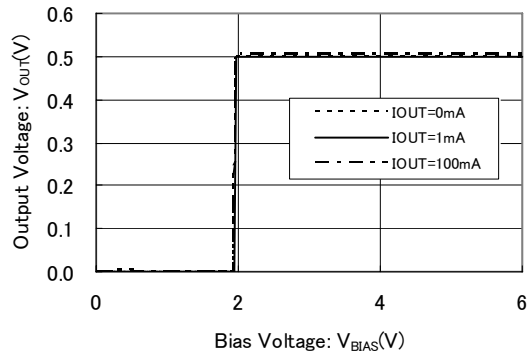

XC6604x121xR-G

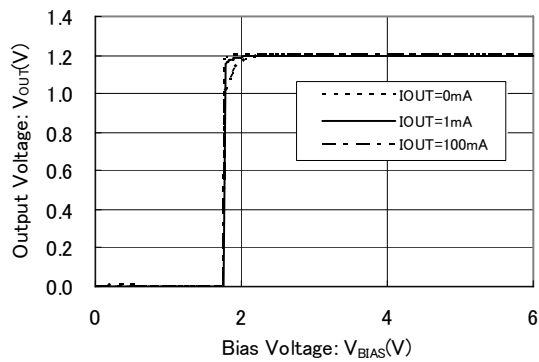

XC6604x181xR-G

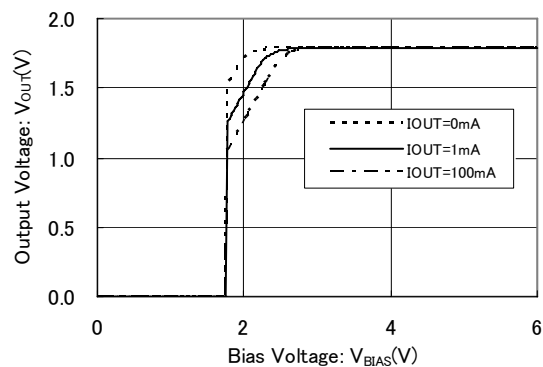

TYPICAL PERFORMANCE CHARACTERISTICS (Continued)

* Unless otherwise stated, $V_{BIAS}=V_{CE}=3.6V$, $V_{IN}=V_{OUT(T)}+0.3V$, $I_{OUT}=1mA$, $I_{LIM Pin}=V_{SS}$, $C_{BIAS}=C_{IN}=1.0\mu F$, $C_L=2.2\mu F$, $T_a=25^\circ C$

(4) Output Voltage vs. Input Voltage

XC6604x051xR-G

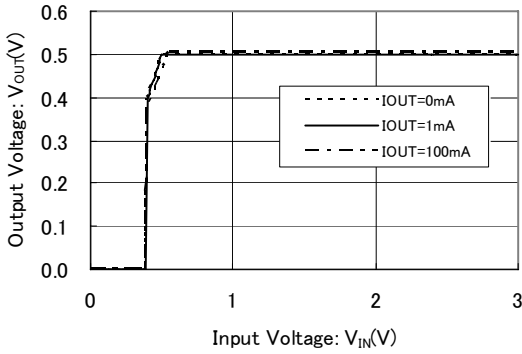

XC6604x121xR-G

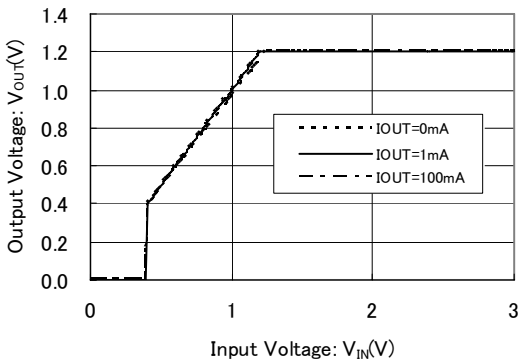

XC6604x181xR-G

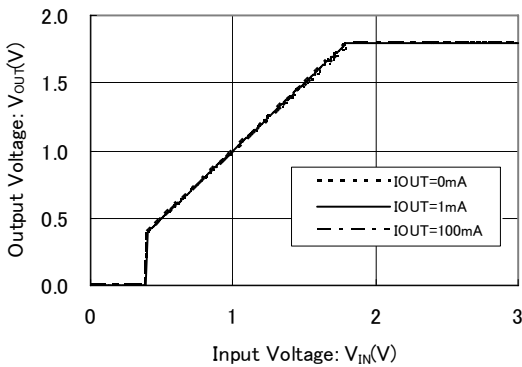

(5) Dropout Voltage vs. Output Current

XC6604x121MR-G

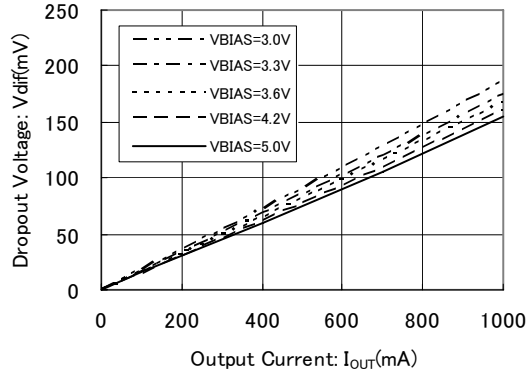

XC6604xxx1MR-G

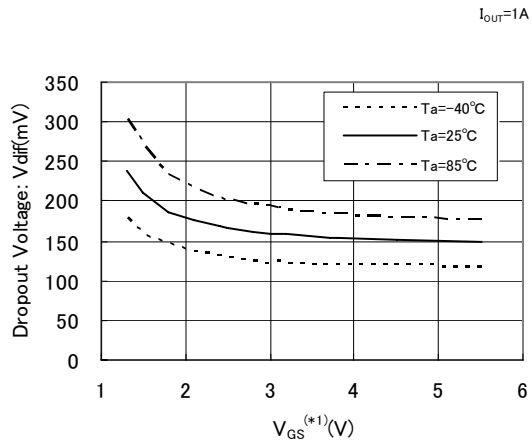

(*1) V_{GS} is a Gate-Source voltage of the driver transistor that is defined as the value of $V_{BIAS} - V_{OUT(E)}$.

A value of the dropout voltage is determined by the value of the V_{GS} .

TYPICAL PERFORMANCE CHARACTERISTICS (Continued)

* Unless otherwise stated, $V_{BIAS}=V_{CE}=3.6V$, $V_{IN}=V_{OUT(T)}+0.3V$, $I_{OUT}=1mA$, $I_{LIM Pin}=V_{SS}$, $C_{BIAS}=C_{IN}=1.0\mu F$, $C_L=2.2\mu F$, $T_a=25^\circ C$

(6) Supply Bias Current vs. Bias Voltage

(7) Supply Input Current vs. Input Voltage

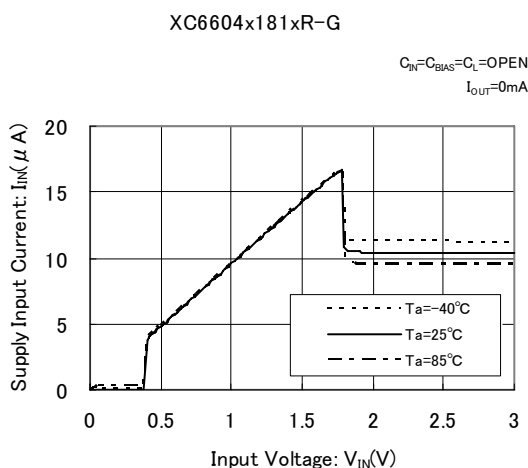
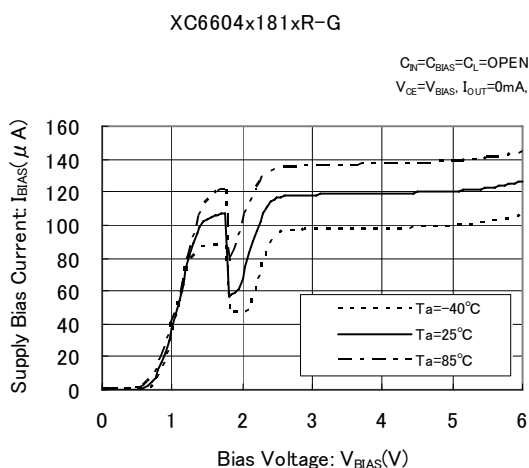
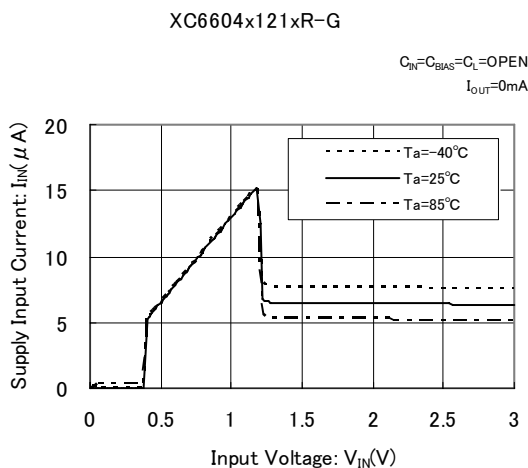
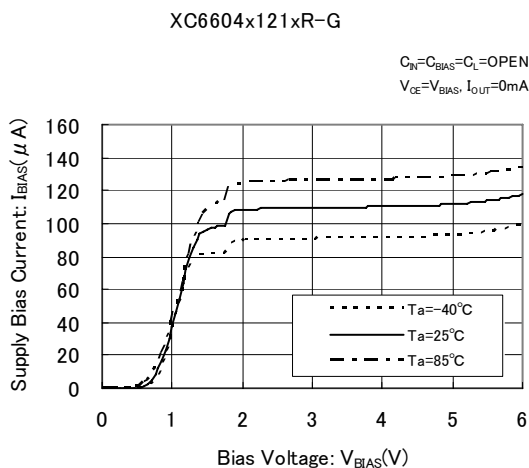
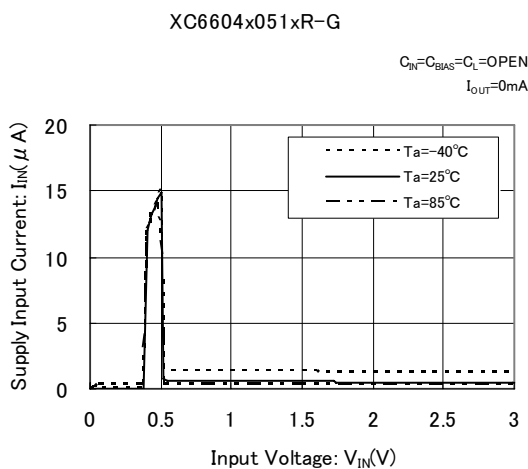
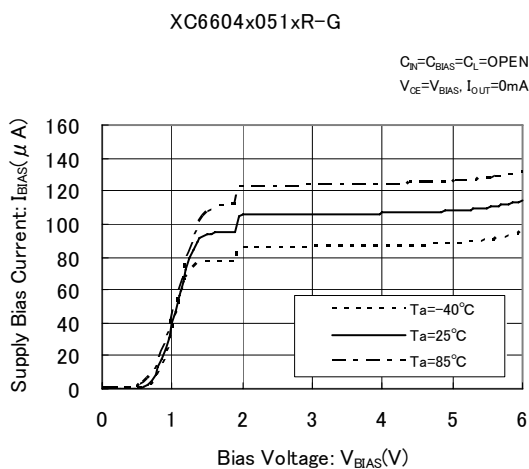

TYPICAL PERFORMANCE CHARACTERISTICS (Continued)

* Unless otherwise stated, $V_{BIAS}=V_{CE}=3.6V$, $V_{IN}=V_{OUT(T)}+0.3V$, $I_{OUT}=1mA$, $I_{LIM Pin}=V_{SS}$, $C_{BIAS}=C_{IN}=1.0\mu F$, $C_L=2.2\mu F$, $T_a=25^\circ C$

(8) Output Voltage vs. Ambient Temperature

XC6604x051xR-G

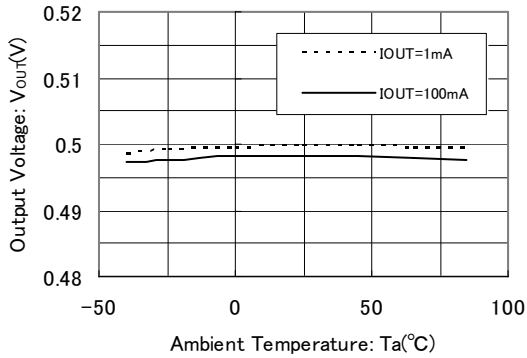

(9) Supply Bias Current vs. Ambient Temperature

XC6604x051xR-G

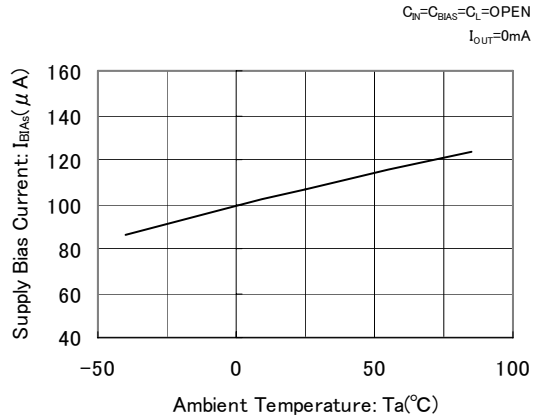

XC6604x121xR-G

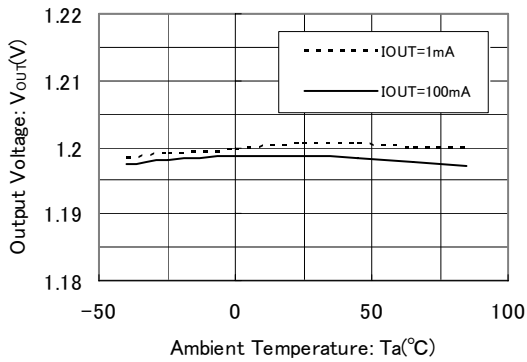

XC6604x121xR-G

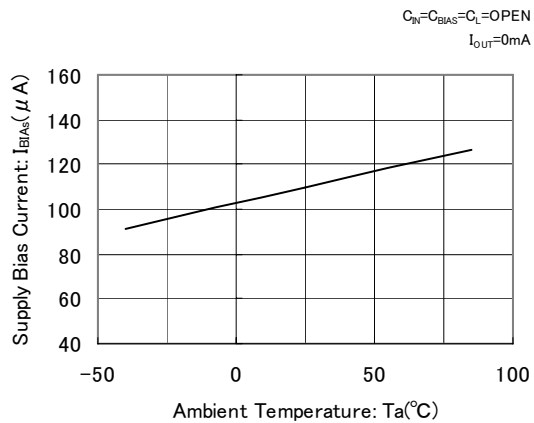

XC6604x181xR-G

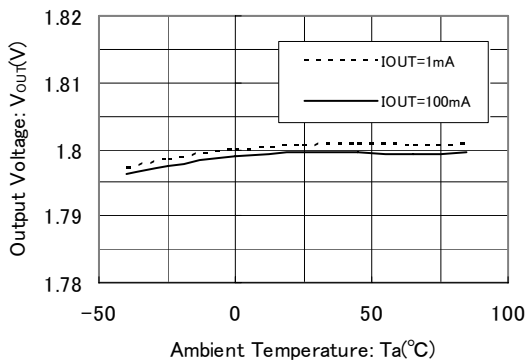

XC6604x181xR-G

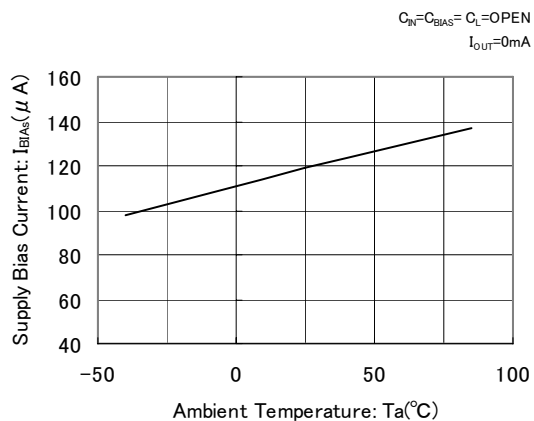

■ TYPICAL PERFORMANCE CHARACTERISTICS (Continued)

* Unless otherwise stated, $V_{BIAS}=V_{CE}=3.6V$, $V_{IN}=V_{OUT(T)}+0.3V$, $I_{OUT}=1mA$, $I_{LIM} Pin=V_{SS}$, $C_{BIAS}=C_{IN}=1.0\mu F$, $C_L=2.2\mu F$, $T_a=25^\circ C$

(10) Supply Input Current vs. Ambient Temperature

XC6604x051xR-G

$C_N=C_{BIAS}=C_L=OPEN$
 $I_{OUT}=0mA$

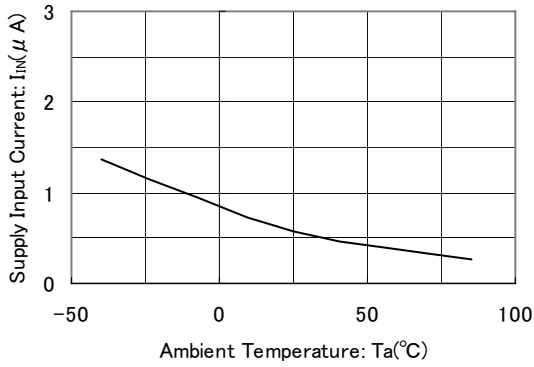

XC6604x121xR-G

$C_N=C_{BIAS}=C_L=OPEN$
 $I_{OUT}=0mA$

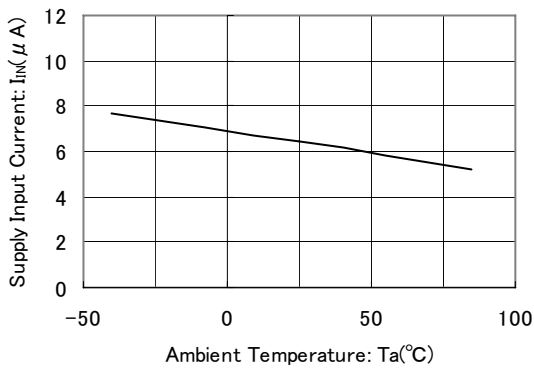

XC6604x181xR-G

$C_N=C_{BIAS}=C_L=OPEN$
 $I_{OUT}=0mA$

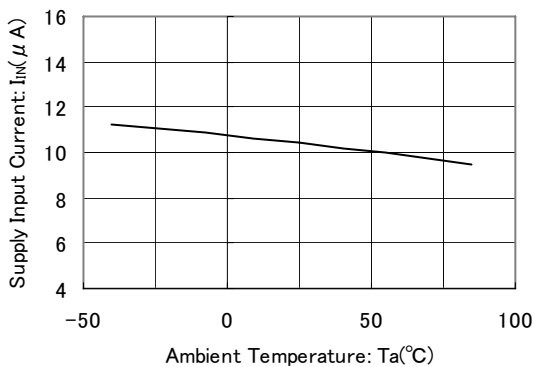

TYPICAL PERFORMANCE CHARACTERISTICS (Continued)

* Unless otherwise stated, $V_{BIAS}=V_{CE}=3.6V$, $V_{IN}=V_{OUT(T)}+0.3V$, $I_{OUT}=1mA$, $I_{LIM Pin}=V_{SS}$, $C_{BIAS}=C_{IN}=1.0 \mu F$, $C_L=2.2 \mu F$, $T_a=25^\circ C$

(11) Bias Transient Response

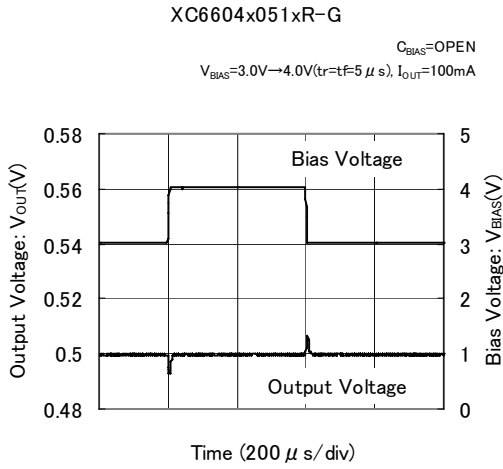

(12) Input Transient Response

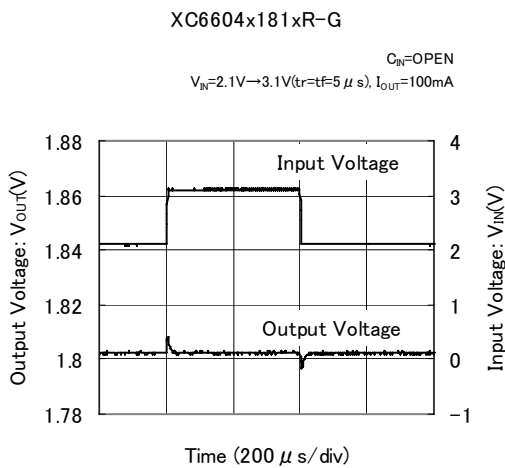
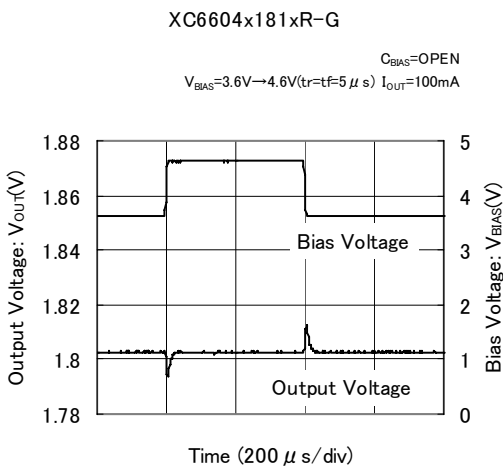
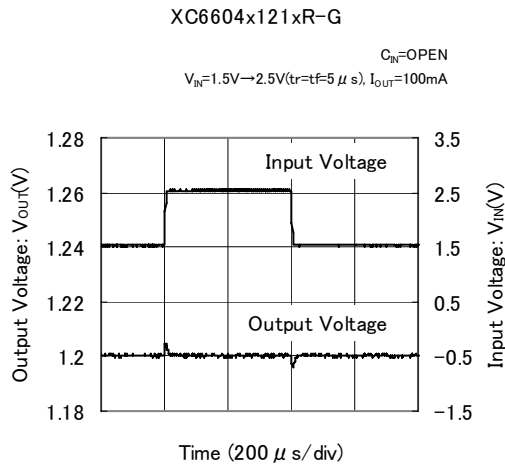
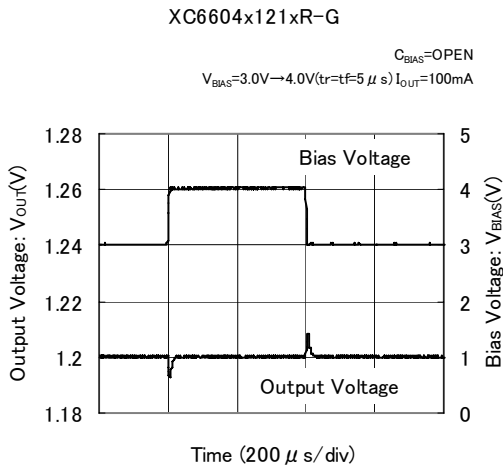
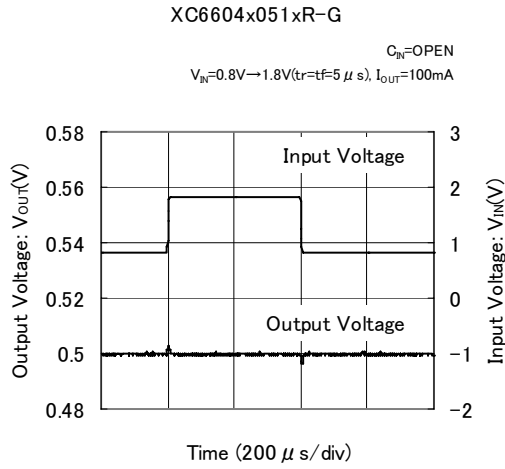

■ TYPICAL PERFORMANCE CHARACTERISTICS (Continued)

* Unless otherwise stated, $V_{BIAS}=V_{CE}=3.6V$, $V_{IN}=V_{OUT(T)}+0.3V$, $I_{OUT}=1mA$, $I_{LIM\ Pin}=V_{SS}$, $C_{BIAS}=C_{IN}=1.0\ \mu F$, $C_L=2.2\ \mu F$, $T_a=25^\circ C$

(13) Load Transient Response

XC6604x051xR-G

$I_{OUT}=1mA \Leftrightarrow 100mA (tr=tf=5\ \mu s)$

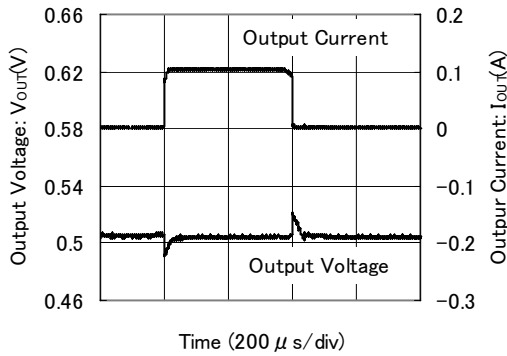

XC6604x121xR-G

$I_{OUT}=1mA \Leftrightarrow 100mA (tr=tf=5\ \mu s)$

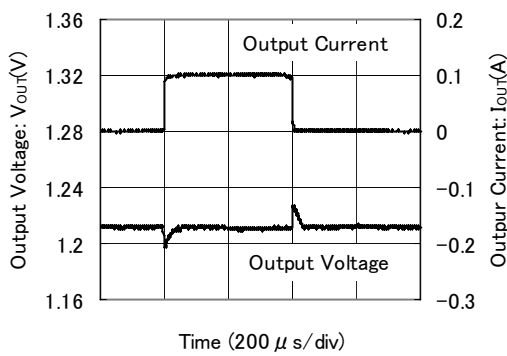

XC6604x181xR-G

$I_{OUT}=1mA \Leftrightarrow 100mA (tr=tf=5\ \mu s)$

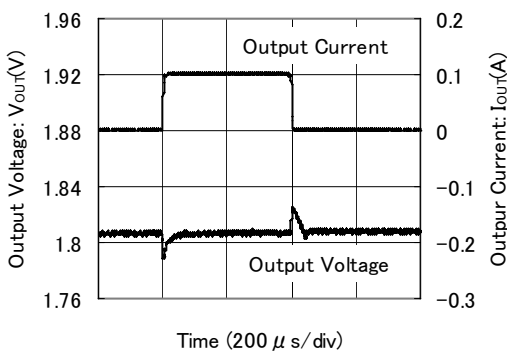

TYPICAL PERFORMANCE CHARACTERISTICS (Continued)

* Unless otherwise stated, $V_{BIAS}=V_{CE}=3.6V$, $V_{IN}=V_{OUT(T)}+0.3V$, $I_{OUT}=1mA$, $I_{LIM Pin}=V_{SS}$, $C_{BIAS}=C_{IN}=1.0\mu F$, $C_L=2.2\mu F$, $T_a=25^\circ C$

(14) CE Input Response

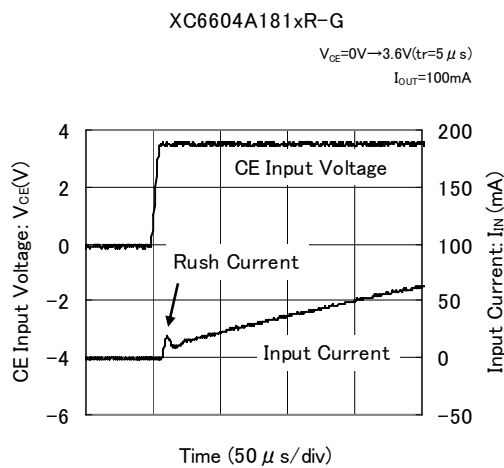
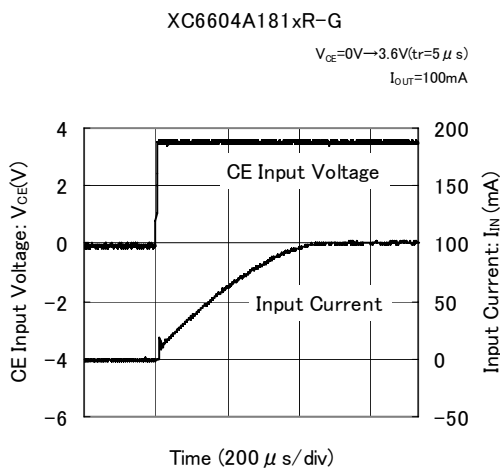
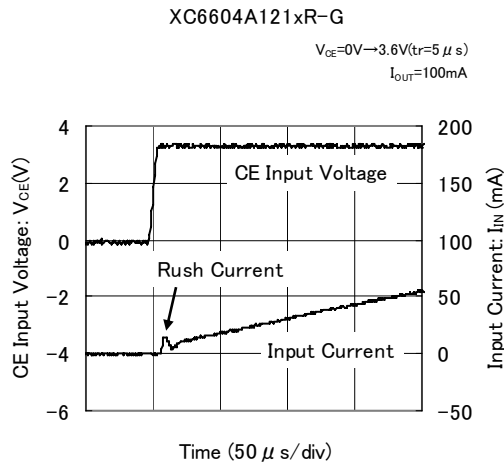
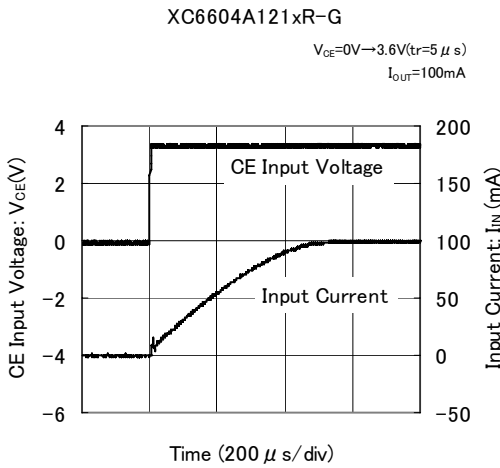
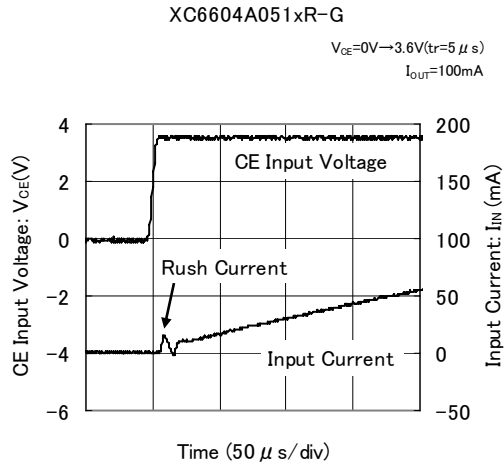
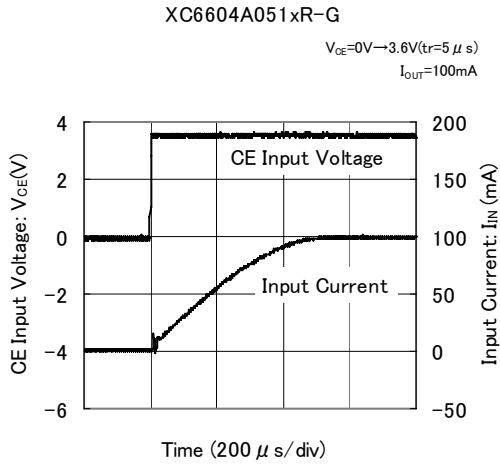

■ TYPICAL PERFORMANCE CHARACTERISTICS (Continued)

* Unless otherwise stated, $V_{BIAS}=V_{CE}=3.6V$, $V_{IN}=V_{OUT(T)}+0.3V$, $I_{OUT}=1mA$, $I_{LIM Pin}=V_{SS}$, $C_{BIAS}=C_{IN}=1.0\mu F$, $C_L=2.2\mu F$, $T_a=25^\circ C$

(14) CE Input Response (Continued)

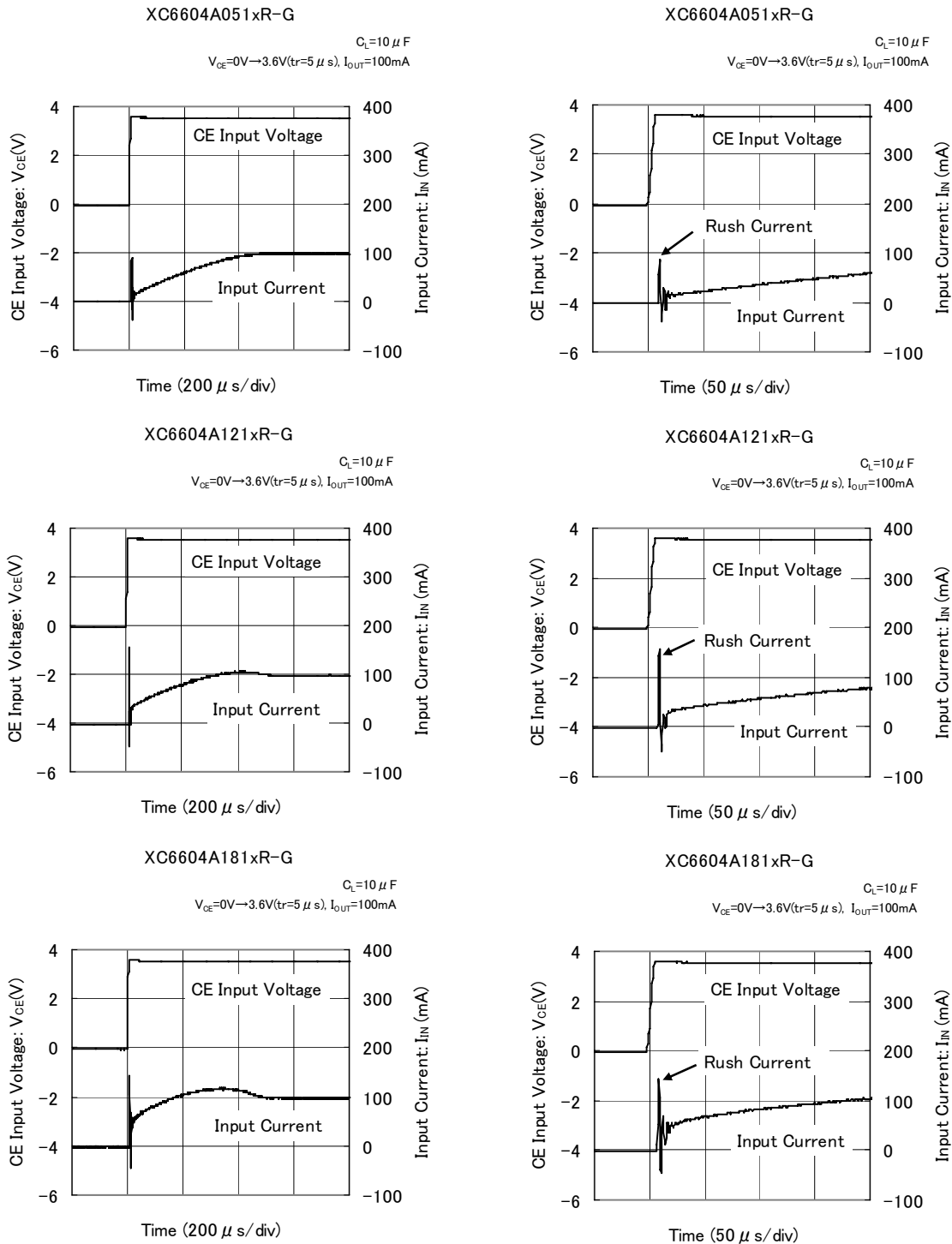

TYPICAL PERFORMANCE CHARACTERISTICS (Continued)

* Unless otherwise stated, $V_{BIAS}=V_{CE}=3.6V$, $V_{IN}=V_{OUT(T)}+0.3V$, $I_{OUT}=1mA$, $I_{LIM Pin}=V_{SS}$, $C_{BIAS}=C_{IN}=1.0\mu F$, $C_L=2.2\mu F$, $T_a=25^\circ C$

(15) CE Rising Response Time

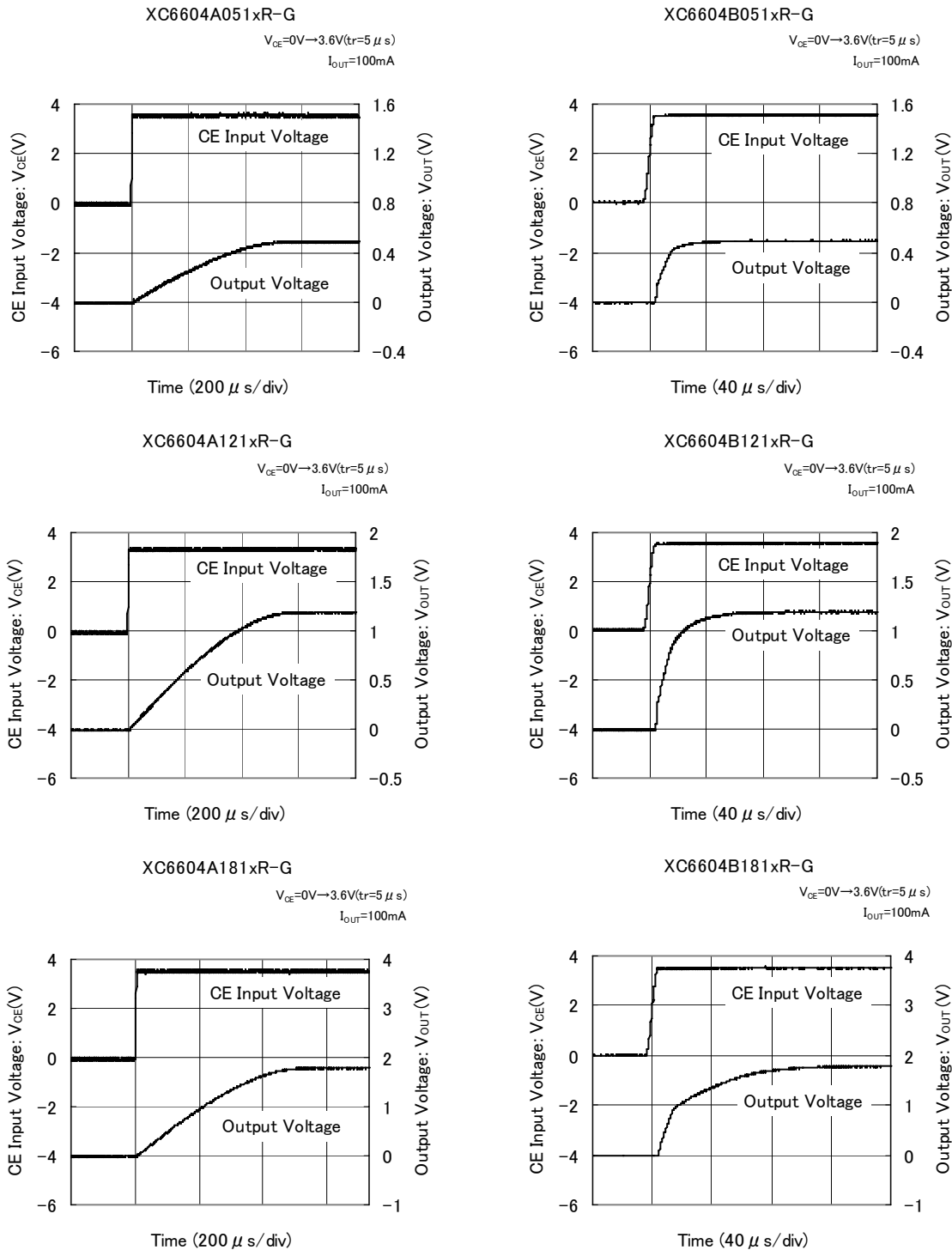

■ TYPICAL PERFORMANCE CHARACTERISTICS (Continued)

* Unless otherwise stated, $V_{BIAS}=V_{CE}=3.6V$, $V_{IN}=V_{OUT(T)}+0.3V$, $I_{OUT}=1mA$, $I_{LIM Pin}=V_{SS}$, $C_{BIAS}=C_{IN}=1.0\mu F$, $C_L=2.2\mu F$, $T_a=25^\circ C$

(16) Rising Response Time

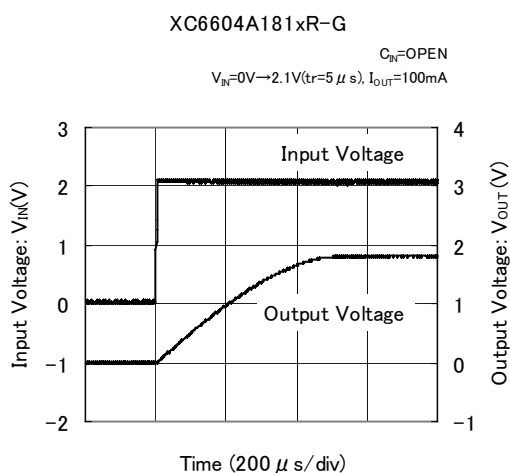
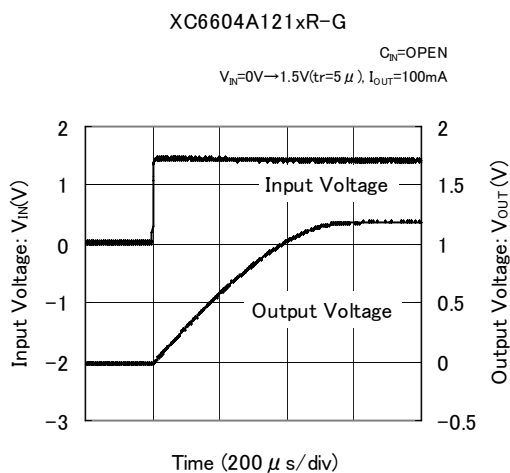
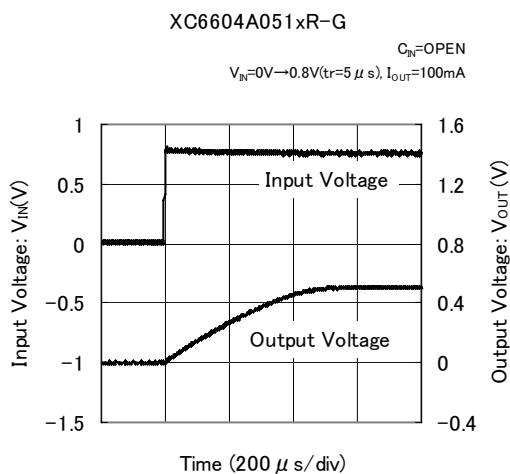

TYPICAL PERFORMANCE CHARACTERISTICS (Continued)

* Unless otherwise stated, $V_{BIAS}=V_{CE}=3.6V$, $V_{IN}=V_{OUT(T)}+0.3V$, $I_{OUT}=1mA$, $I_{LIM Pin}=V_{SS}$, $C_{BIAS}=C_{IN}=1.0\mu F$, $C_L=2.2\mu F$, $T_a=25^\circ C$

(17) Bias Voltage Ripple Rejection Rate

XC6604x051xR-G

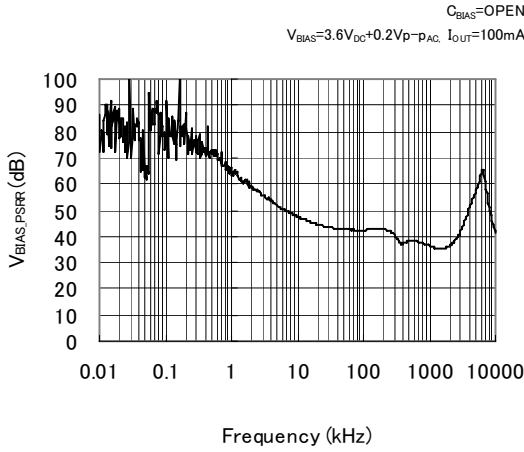

(18) Input Voltage Ripple Rejection Rate

XC6604x051xR-G

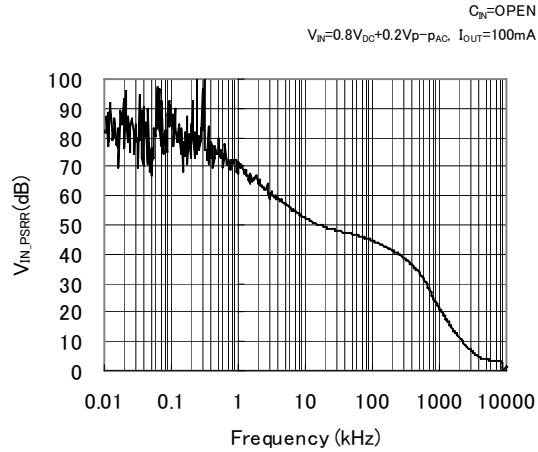

XC6604x121xR-G

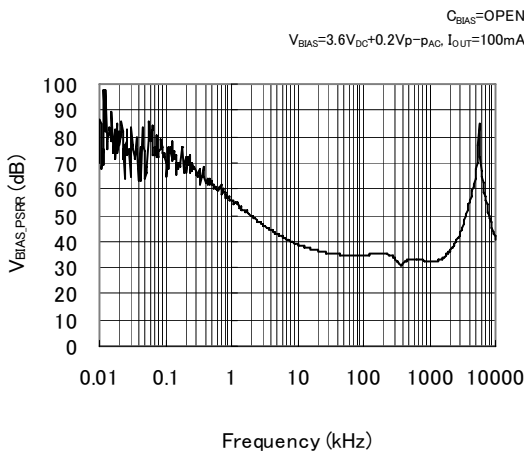

XC6604x121xR-G

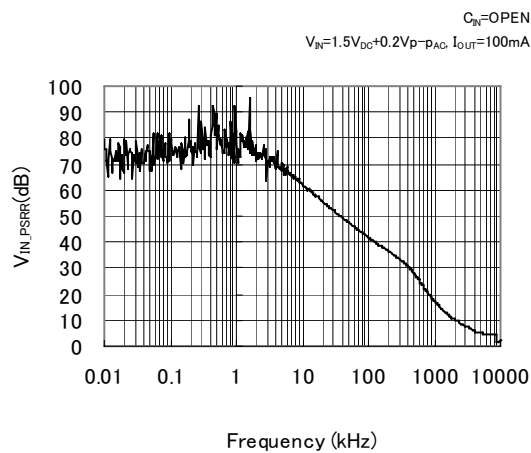

XC6604x181xR-G

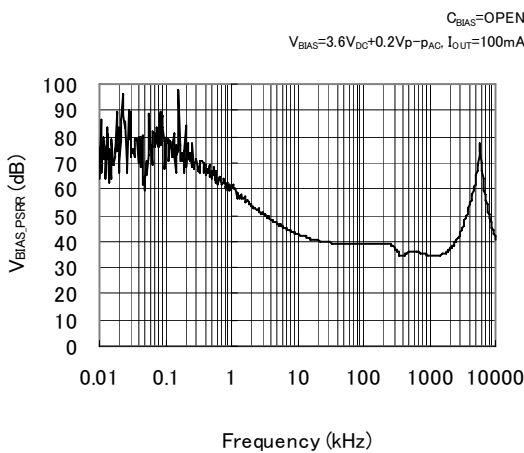

XC6604x181xR-G

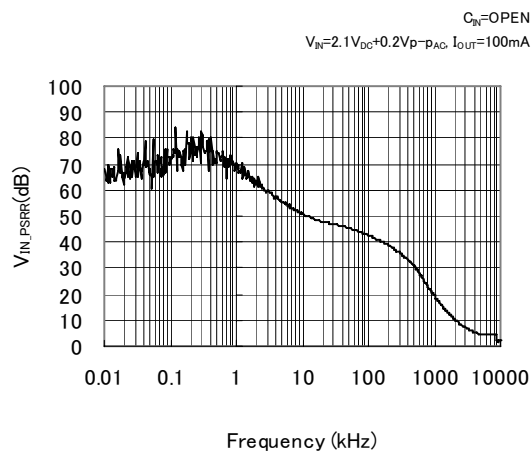

PACKAGING INFORMATION

USP-6C
(unit : mm)

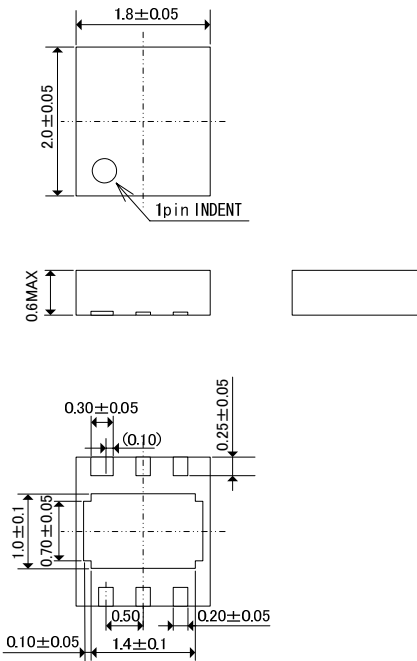

SOT-26W
(unit : mm)

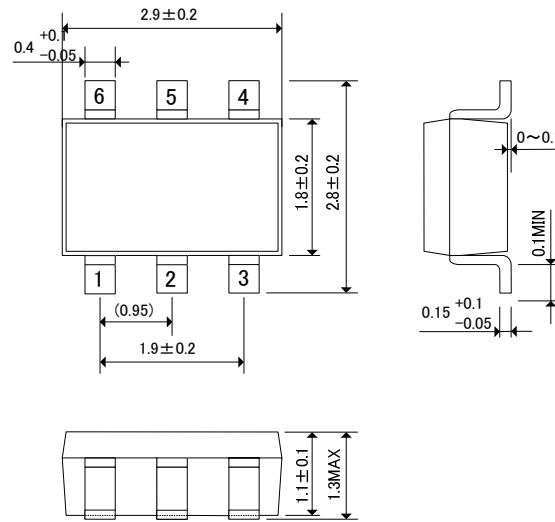

● USP-6C Reference Pattern Layout (unit: mm)

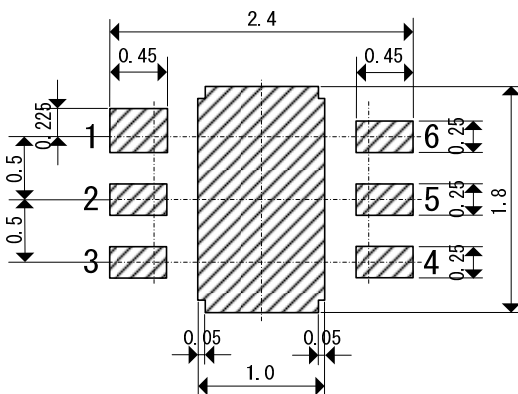

● USP-6C Reference Metal Mask Design (unit: mm)

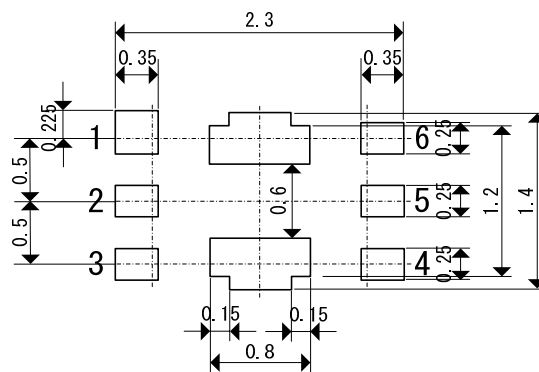

PACKAGING INFORMATION (Continued)

● USP-6C Power Dissipation

Power dissipation data for the USP-6C is shown in this page.
 The value of power dissipation varies with the mount board conditions.
 Please use this data as one of reference data taken in the described condition.

1. Measurement Condition (Reference data)

- Condition: Mount on a board
- Ambient: Natural convection
- Soldering: Lead (Pb) free
- Board: Dimensions 40 x 40 mm (1600 mm² in one side)
 Copper (Cu) traces occupy 50% of the board area
 In top and back faces
 Package heat-sink is tied to the copper traces
- Material: Glass Epoxy (FR-4)
- Thickness: 1.6 mm
- Through-hole: 4 x 0.8 Diameter

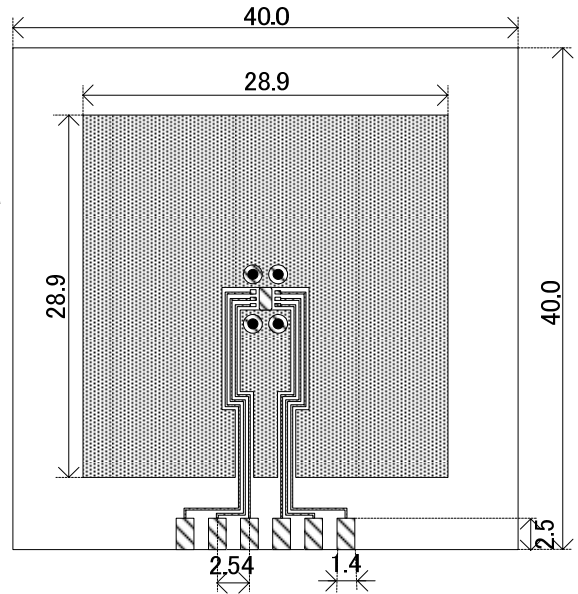

Evaluation Board (Unit: mm)

2. Power Dissipation vs. Ambient temperature

Board Mount ($T_j \text{ max} = 125^\circ\text{C}$)

Ambient Temperature (°C)	Power Dissipation Pd (mW)	Thermal Resistance (°C/W)
25	1000	100.00
85	400	

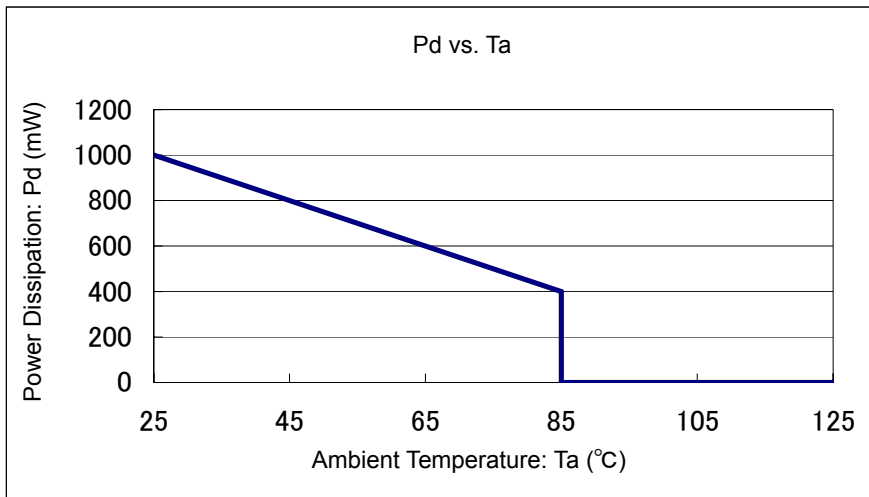

■ PACKAGING INFORMATION (Continued)

● SOT-26W Power Dissipation

Power dissipation data for the SOT-26W is shown in this page.
The value of power dissipation varies with the mount board conditions.
Please use this data as one of reference data taken in the described condition.

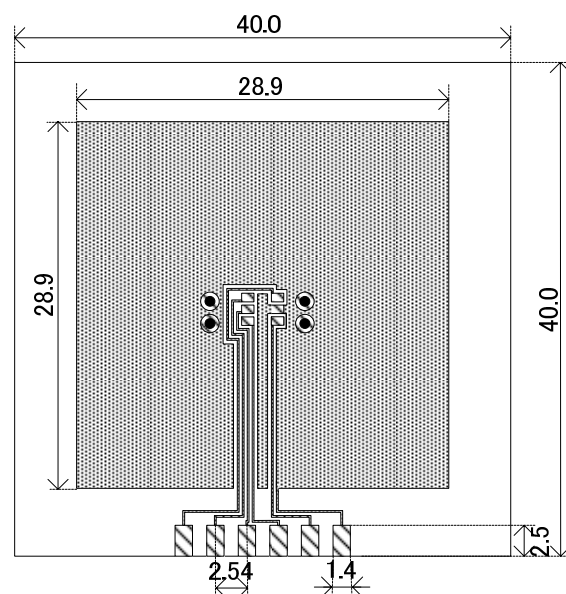

Evaluation Board (Unit: mm)

1. Measurement Condition (Reference data)

- Condition: Mount on a board
- Ambient: Natural convection
- Soldering: Lead (Pb) free
- Board: Dimensions 40 x 40 mm (1600 mm² in one side)
Copper (Cu) traces occupy 50% of the board area
In top and back faces
Package heat-sink is tied to the copper traces
(Board of SOT-26 is used.)
- Material: Glass Epoxy (FR-4)
- Thickness: 1.6 mm
- Through-hole: 4 x 0.8 Diameter

2. Power Dissipation vs. Ambient temperature

Board Mount (T_j max = 125°C)

Ambient Temperature (°C)	Power Dissipation Pd (mW)	Thermal Resistance (°C/W)
25	600	166.67
85	240	

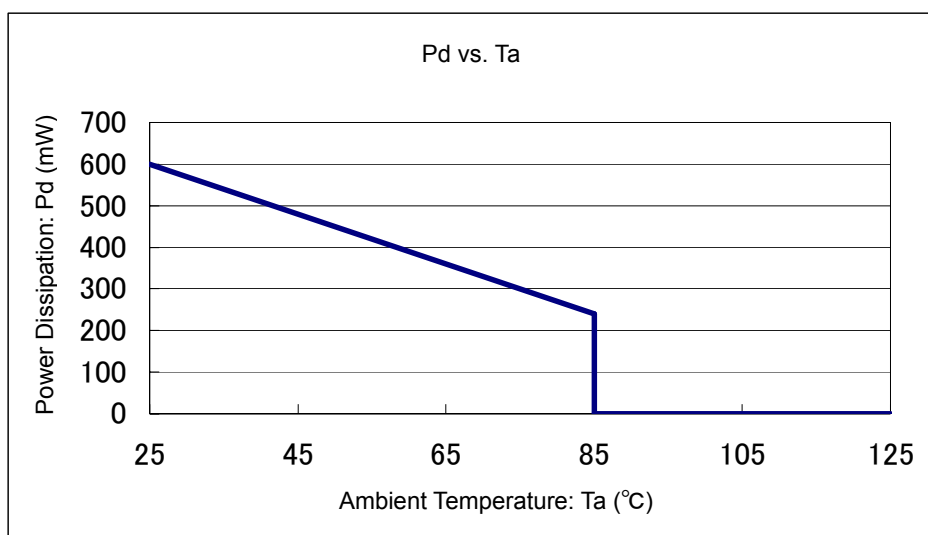

MARKING RULE

① represents product series

MARK	PRODUCT SERIES
T	XC6604A*****-G
U	XC6604B*****-G

② represents output voltage

MARK	OUTPUT VOLTAGE (V)	MARK	OUTPUT VOLTAGE (V)
A	0.5	K	1.2
B	0.6	L	1.3
C	0.7	M	1.4
D	0.8	N	1.5
E	0.9	P	1.6
F	1.0	R	1.7
H	1.1	S	1.8

③④ represents production lot number
 01 to 09, 0A to 0Z, 11 to 9Z, A1 to A9, AA to Z9, B1 to ZZ in order.
 (G, I, J, O, Q, W excluded)
 *No character inversion used.

SOT-26W

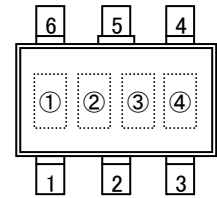

■ MARKING RULE (Continued)

① represents product series

MARK	PRODUCT SERIES
U	XC6604*****-G

② represents regulator type

MARK	PRODUCT SERIES
A	XC6604A*****-G
B	XC6604B*****-G

③ represents output voltage

MARK	OUTPUT VOLTAGE (V)	MARK	OUTPUT VOLTAGE (V)
A	0.5	K	1.2
B	0.6	L	1.3
C	0.7	M	1.4
D	0.8	N	1.5
E	0.9	P	1.6
F	1.0	R	1.7
H	1.1	S	1.8

④⑤ represents production lot number

01 to 09, 0A to 0Z, 11 to 9Z, A1 to A9, AA to Z9, B1 to ZZ in order.
(G, I, J, O, Q, W excluded)

*No character inversion used.

USP-6C

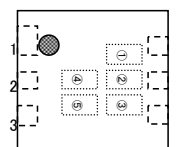

1. The products and product specifications contained herein are subject to change without notice to improve performance characteristics. Consult us, or our representatives before use, to confirm that the information in this datasheet is up to date.
2. We assume no responsibility for any infringement of patents, patent rights, or other rights arising from the use of any information and circuitry in this datasheet.
3. Please ensure suitable shipping controls (including fail-safe designs and aging protection) are in force for equipment employing products listed in this datasheet.
4. The products in this datasheet are not developed, designed, or approved for use with such equipment whose failure or malfunction can be reasonably expected to directly endanger the life of, or cause significant injury to, the user.
(e.g. Atomic energy; aerospace; transport; combustion and associated safety equipment thereof.)
5. Please use the products listed in this datasheet within the specified ranges.
Should you wish to use the products under conditions exceeding the specifications, please consult us or our representatives.
6. We assume no responsibility for damage or loss due to abnormal use.
7. All rights reserved. No part of this datasheet may be copied or reproduced without the prior permission of TOREX SEMICONDUCTOR LTD.

TOREX SEMICONDUCTOR LTD.

X-ON Electronics

Largest Supplier of Electrical and Electronic Components

Click to view similar products for [LDO Voltage Regulators](#) category:

Click to view products by [Torex Semiconductor](#) manufacturer:

Other Similar products are found below :

[L79M05TL-E](#) [PT7M8202B12TA5EX](#) [TCR3DF185,LM\(CT](#) [TCR3DF24,LM\(CT](#) [TCR3DF285,LM\(CT](#) [TCR3DF31,LM\(CT](#)
[TCR3DF45,LM\(CT](#) [MP2013GQ-33-Z](#) [059985X](#) [NCP4687DH15T1G](#) [701326R](#) [TCR2EN28,LF\(S](#) [NCV8170AXV250T2G](#)
[TCR3DF27,LM\(CT](#) [TCR3DF19,LM\(CT](#) [TCR3DF125,LM\(CT](#) [TCR2EN18,LF\(S](#) [AP2112R5A-3.3TRG1](#) [AP7315-25W5-7](#)
[IFX30081LDVGRNXUMA1](#) [AP2111H-1.2TRG1](#) [ZLDO1117QK50TC](#) [AZ1117ID-ADJTRG1](#) [TCR3DG12,LF](#) [MIC5514-3.3YMT-T5](#)
[MIC5512-1.2YMT-T5](#) [MIC5317-2.8YM5-T5](#) [SCD7912BTG](#) [NCP154MX180270TAG](#) [SCD33269T-5.0G](#) [NCV8170BMX330TCG](#)
[NCV8170AMX120TCG](#) [NCP706ABMX300TAG](#) [NCP153MX330180TCG](#) [NCP114BMX075TCG](#) [MC33269T-3.5G](#) [CAT6243-ADJCMT5T](#)
[TCR3DG33,LF](#) [AP2127N-1.0TRG1](#) [BD3021HFP-MTR](#) [TCR4DG35,LF](#) [LT1117CST-3.3](#) [TAR5S15U\(TE85L,F\)](#) [TAR5S18U\(TE85L,F\)](#)
[TCR3UG19A,LF](#) [TCR4DG105,LF](#) [NCV8170AMX360TCG](#) [MIC94310-NYMT-T5](#) [NCV4266-2CST33T3G](#) [NCV8186BMN175TAG](#)