

XC8111AA01MR Evaluation Board User Manual

6Vmax, 1A Load switch IC with ideal diode function

CAUTION

ENGINEERING EVALUATION PURPOSES ONLY

This evaluation board is made for the purpose of the product evaluation. It is strictly prohibited to use this evaluation board for any other purpose.

Torex Semiconductor does not guarantee that all samples will perform in exactly the same way and we recommend that you always consult our product data sheets for the minimum and maximum specifications.

It is also important that you evaluate all our products carefully before mass

XC8111AA01MR Evaluation Board

6Vmax, 1A Load switch IC with ideal diode function

Evaluation Board Picture



Evaluation Board SPEC

PARAMETER		SYMBOL	MIN.	TYP.	MAX.	UNITS
Input Voltage	Applied voltage to V_{OUT} : 0V ~ 1.5V	V_{IN}	1.5	-	6.0	V
	Applied voltage to V_{OUT} : 1.5V ~ 6.0V		0.0	-	6.0	
Output Voltage	Applied voltage to V_{IN} : 0V ~ 1.5V	V_{OUT}	1.5	-	6.0	V
	Applied voltage to V_{IN} : 1.5V ~ 6.0V		0.0	-	6.0	
Output Current ($T_a=25^\circ\text{C}$)	$1.5\text{V} \leq V_{IN} \leq 1.7\text{V}$	I_{OUT}	-	-	300	mA
	$1.7\text{V} < V_{IN} \leq 6.0\text{V}$		-	-	1000	mA

XC8110/XC8110 Series Features

- Input Voltage Range 1.5V ~ 6.0V
- Max Output Current 1000mA
- Ideal Diode function
 - Forward Voltage 20mV
 - Quiescent Current 3.6 μ A
 - Stand-by Current 0.65 μ A
- ORing connection available
- Built-in protection function (Over Current, Thermal Shutdown)

XC8111AA01MR Evaluation Board

6Vmax, 1A Load switch IC with ideal diode function

Quick Start Procedure

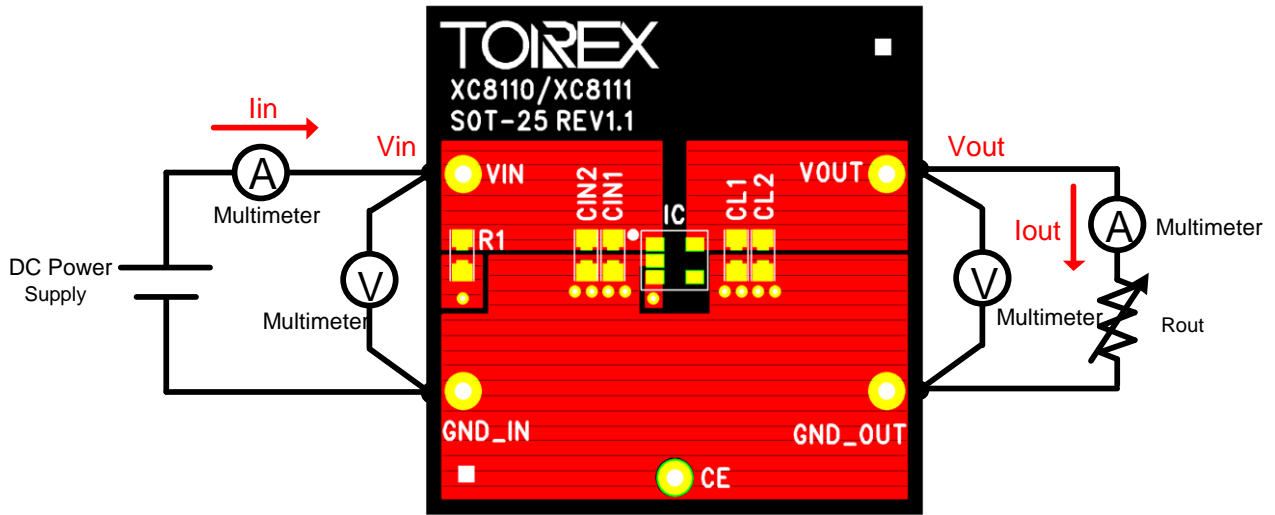

Active : CE="H" (1.2V~6.0V)
 Stand-by : CE="L" (0V~0.3V)

XC8111AA01MR Evaluation Board

6Vmax, 1A Load switch IC with ideal diode function

Schematic

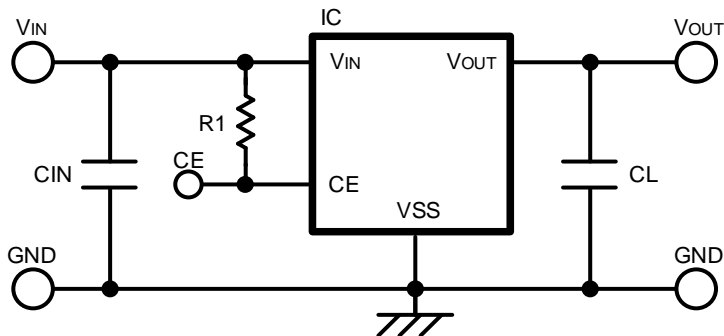

BOM

Required Circuit Component

Item	Value	Description	Size [mm]	Part Number	Manufacture
IC	-	Load switch IC with ideal diode	SOT-25	XC8111AA01MR-G	TOREX
CIN1	0.1uF	Ceramic cap., 50V	1608	C1608X7R1H104K	TDK
CIN2	-	-	-	-	-
CL1	0.1uF	Ceramic cap., 50V	1608	C1608X7R1H104K	TDK
CL2	-	-	-	-	-
R1	-	-	-	-	-

XC8111AA01MR Evaluation Board

6Vmax, 1A Load switch IC with ideal diode function

PCB Layout

Layer 1

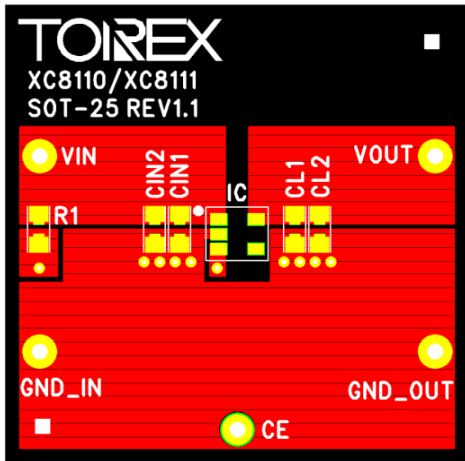

Layer 2

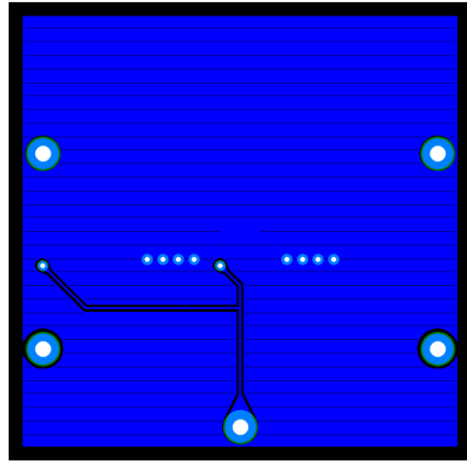

XC8111AA01MR Evaluation Board

6Vmax, 1A Load switch IC with ideal diode function

【Appendix】 Typical Application Circuit

Diode / substitute for load switch

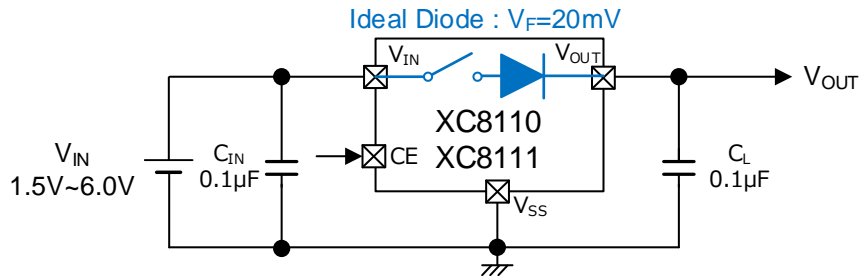

OR circuit: backup circuit, etc.

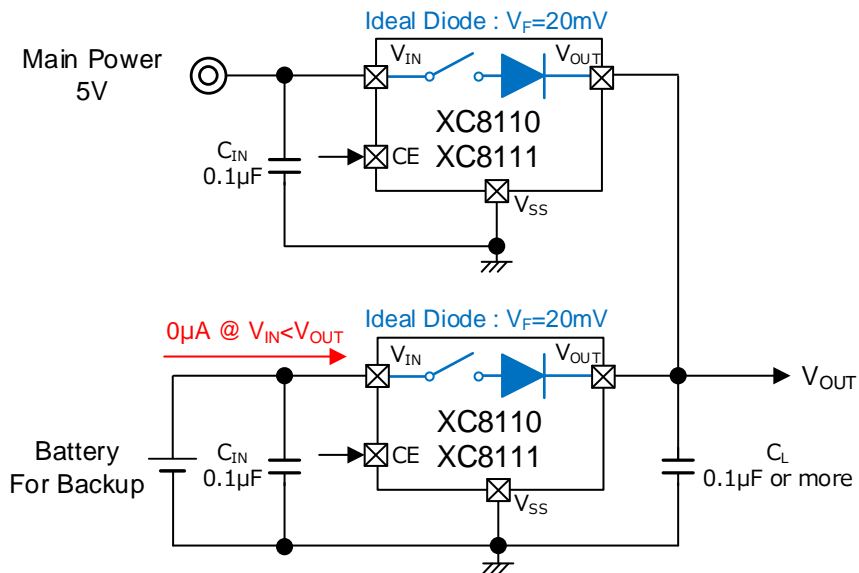

X-ON Electronics

Largest Supplier of Electrical and Electronic Components

Click to view similar products for [Power Management IC Development Tools](#) *category:*

Click to view products by [Torex Semiconductor](#) *manufacturer:*

Other Similar products are found below :

[EVB-EP5348UI](#) [BQ25010EVM](#) [ISL80019AEVAL1Z](#) [ISLUSBI2CKIT1Z](#) [ISL8002AEVAL1Z](#) [ISL91108IIA-EVZ](#) [MAX8556EVKIT](#)
[MAX15005AEVKIT+](#) [ISL28022EVKIT1Z](#) [STEVAL-ISA008V1](#) [DRI0043](#) [KITPF8100FRDMEVM](#) [EVB-EN6337QA](#)
[SAMPLEBOXILD8150TOBO1](#) [MAX18066EVKIT#](#) [AP62300WU-EVM](#) [KITA2GTC387MOTORCTRTOBO1](#) [AEK-MOT-TK200G1](#)
[EVLONE65W](#) [STEVAL-ILH006V1](#) [STEVAL-IPE008V2](#) [STEVAL-IPP001V2](#) [STEVAL-ISA013V1](#) [STEVAL-ISA067V1](#) [STEVAL-](#)
[ISQ002V1](#) [TPS2306EVM-001](#) [TPS2330EVM-185](#) [TPS40001EVM-001](#) [SECO-HVDCDC1362-15W-GEVB](#) [BTS7030-2EPA](#)
[LT8638SJV#WPBF](#) [LTC3308AIV#WTRPBF](#) [TLT807B0EPV](#) [BTS71033-6ESA](#) [EV13N91A](#) [EASYPIC V8 OVER USB-C](#) [EV55W64A](#)
[CLICKER 4 FOR STM32F4](#) [EASYMX PRO V7A FOR STM32](#) [CLICKER 4 FOR PIC18F](#) [Si8285_86v2-KIT](#) [PAC52700EVK1](#) [NCP-](#)
[NCV51752D2PAK3LGEVB](#) [ISL81807EVAL1Z](#) [AP33772S-EVB](#) [EVALM7HVIGBTFCINV4TOBO1](#) [903-0300-000](#) [902-0173-000](#) [903-](#)
[0301-000](#) [ROA1286023/1](#)