

28V Low Power Consumption 150mA Voltage Regulators (with Stand-by Function)

☆AEC-Q100 Grade2

■ GENERAL DESCRIPTION

XD6216 series are positive voltage regulator ICs with 28V of operation voltage. The series consists of a voltage reference, an error amplifier, a current limiter, a thermal shutdown circuit and a phase compensation circuit plus a driver transistor. The output voltage is selectable in 0.1V increments within the range of 1.8V to 12V using laser trimming technologies.

The output stabilization capacitor (C_L) is also compatible with low ESR ceramic capacitors.

The over current protection circuit and the thermal shutdown circuit are built-in. These two protection circuits will operate when the output current reaches current limit level or the junction temperature reaches temperature limit level.

The CE function enables the output to be turned off and the IC becomes a stand-by mode resulting in greatly reduced power consumption.

■ APPLICATIONS

- Car navigation systems
- Car audios
- Car-mounted camera
- Other automotive accessories

■ FEATURES

Max Output Current	: 150mA ($V_{IN}=V_{OUT}+3.0V$)
Low Power Consumption	: 5 μ A
Stand-by Current	: Less than 0.1 μ A
Dropout Voltage	: 190mV@ $I_{OUT}=20mA$ ($V_{OUT}=5.0V$)
Input Voltage Range	: 2.0V ~ 28.0V
Output Voltage Range	: 1.8V ~ 12.0V (0.1V Step)
Fixed Output Accuracy	: $\pm 1\%$ ($V_{OUT} \geq 2.0V$) $\pm 20mV$ ($V_{OUT} \leq 1.9V$)
High Ripple Rejection	: 30dB@1kHz
Built-in Protection	: Current Limit Thermal Shutdown
Output Capacitor	: Ceramic Capacitor Compatible
Operating Ambient Temperature	: -40 $^{\circ}$ C ~ +105 $^{\circ}$ C
Packages	: SOT-25 : SOT-89-5
Environmentally Friendly	: EU RoHS Compliant, Pb Free

■ TYPICAL APPLICATION CIRCUIT

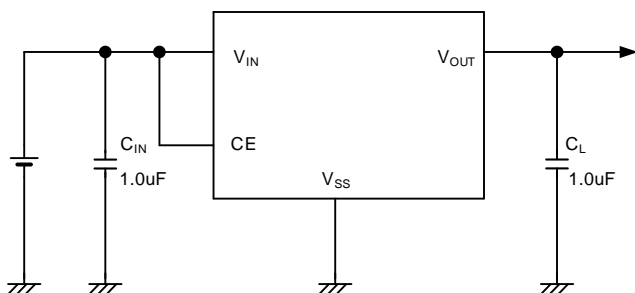

■ TYPICAL PERFORMANCE CHARACTERISTICS

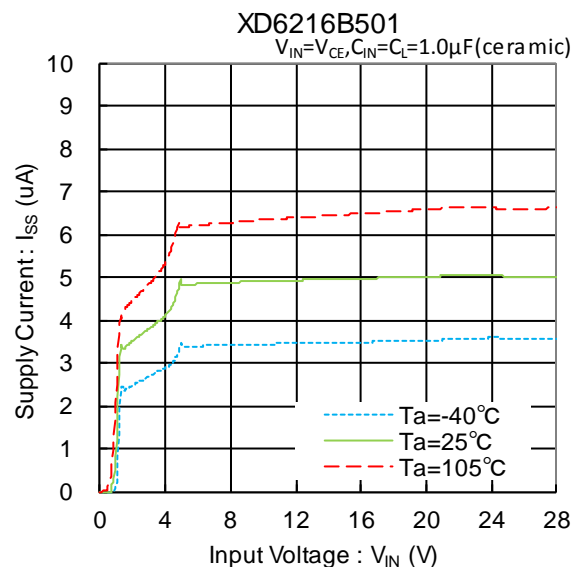

■ BLOCK DIAGRAMS

● XD6216 Series

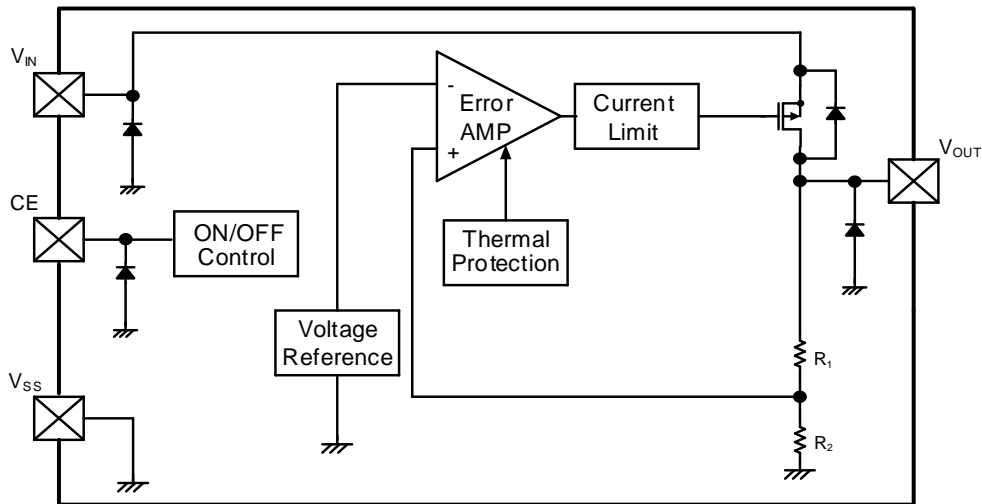

*Diodes inside the circuit are an ESD protection diode and parasitic diodes.

■ PRODUCT CLASSIFICATION

● Ordering Information

XD6216①②③④⑤⑥-⑦^(*)

DESIGNATOR	ITEM	SYMBOL	DESCRIPTION
①	TYPE	B	Refer to Selection Guide
②③	Output Voltage	18~C0	For the voltage within 1.8V~9.9V (0.1V increments); e.g. 2.5V ⇒ 25, 5.0V ⇒ 50 For the voltage within 10.0V~12.0V (0.1V increments); e.g. 10.6V ⇒ A6, 11.2V ⇒ B2, 12.0V ⇒ C0
④	Output Voltage Accuracy	1	±1%
⑤⑥-⑦ ^(*)	Packages (Order Unit)	MR-Q	SOT-25 (3,000pcs/Reel)
		PR-Q	SOT-89-5 (1,000pcs/Reel)

^(*) The "-Q" suffix denotes "AEC-Q100" and "Halogen and Antimony free" as well as being fully EU RoHS compliant.

● Selection Guide

TYPE	CE function
B	Yes

■ STANDARD VOLTAGE

● Examples for standard voltage

V _{OUT}	PACKAGES	
	SOT-25	SOT-89-5
3.3V	XD6216B331MR-Q	XD6216B331PR-Q
5.0V	XD6216B501MR-Q	XD6216B501PR-Q
8.0V	XD6216B801MR-Q	XD6216B801PR-Q

Output voltages can be set internally from 1.8V to 12.0V. For other voltages, please contact your local Torex sales office or distribution

■ PIN CONFIGURATION

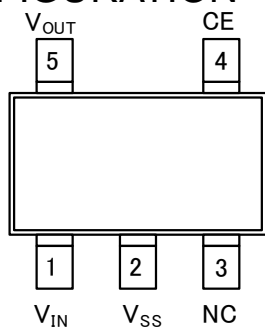

SOT-25
(TOP VIEW)

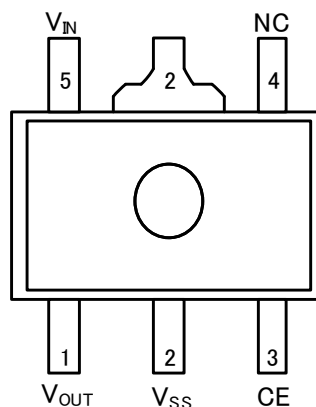

SOT-89-5
(TOP VIEW)

■ PIN ASSIGNMENT

PIN NUMBER		PIN NAME	FUNCTION
SOT-25	SOT-89-5		
1	5	V _{IN}	Power Supply Input
2	2	V _{SS}	Ground
3	4	NC	No Connection
4	3	CE	ON/OFF Control
5	1	V _{OUT}	Output

■ FUNCTION

PIN NAME	DESIGNATOR	IC OPERATION
CE	L	Stand-by
	H	Active
	OPEN	Undefined state*

* Please avoid the state of OPEN, and make CE Pin arbitrary fixed potential.

■ ABSOLUTE MAXIMUM RATINGS

1) XD6216 Series

T_a=25°C

PARAMETER	SYMBOL	RATINGS	UNITS
V _{IN} Pin Voltage	V _{IN}	-0.3 ~ +30.0	V
Output Current	I _{OUT}	300 ^{(*)1}	mA
Output Voltage	V _{OUT}	-0.3 ~ V _{IN} +0.3 or +30.0 ^{(*)2}	V
CE Input Voltage	V _{CE}	-0.3 ~ +30.0	V
Power Dissipation	Pd	250	mW
		600 (40mm x 40mm Standard board) ^{(*)3}	
		760 (JESD51-7 board) ^{(*)3}	
		500	
		1300 (40mm x 40mm Standard board) ^{(*)3}	
1750 (JESD51-7 board) ^{(*)3}			
Operating Ambient Temperature	T _{opr}	-40 ~ +105	°C
Storage Temperature	T _{stg}	-55 ~ +125	°C

All voltages are described based on the V_{SS}.

^{(*)1} Please use within the range of I_{OUT} ≤ Pd / (V_{IN}-V_{OUT})

^{(*)2} The maximum rating corresponds to the lowest value between V_{IN}+0.3 or +30.0.

^{(*)3} The power dissipation figure shown is PCB mounted and is for reference only.

The mounting condition is please refer to PACKAGING INFORMATION.

ELECTRICAL CHARACTERISTICS

Ta=25°C

PARAMETER	SYMBOL	CONDITIONS	MIN.	TYP.	MAX.	UNITS	CIRCUIT
Output Voltage	V _{OUT(E)} ⁽²⁾	I _{OUT} =20mA, V _{CE} =V _{IN} -40°C ≤ Ta ≤ 105°C ⁽⁴⁾	E-0			V	①
Maximum Output Current	I _{OUTMAX}	V _{IN} =V _{OUT(T)} +3.0V ⁽¹⁾ , V _{CE} =V _{IN} (V _{OUT(T)} ≥ 3.0V)	150	-	-	mA	①
		V _{IN} =V _{OUT(T)} +3.0V ⁽¹⁾ , V _{CE} =V _{IN} (V _{OUT(T)} < 3.0V)	100	-	-		
Load Regulation	ΔV _{OUT}	1mA ≤ I _{OUT} ≤ 50mA, V _{CE} =V _{IN} (V _{OUT(T)} ≤ 7.0V)	-	50	90	mV	①
		1mA ≤ I _{OUT} ≤ 50mA, V _{CE} =V _{IN} (7.0V < V _{OUT(T)})	-	110	140	mV	①
Dropout Voltage1	V _{dif1} ⁽³⁾	I _{OUT} =20mA, V _{CE} =V _{IN}	-	E-1		mV	①
Dropout Voltage2	V _{dif2} ⁽³⁾	I _{OUT} =100mA, V _{CE} =V _{IN}	-	E-2		mV	①
Supply Current	I _{SS}	V _{CE} =V _{IN} -40°C ≤ Ta ≤ 105°C ⁽⁴⁾	1.0	5.0	9.0	μA	②
Stand-by Current	I _{STB}	V _{CE} =V _{SS} -40°C ≤ Ta ≤ 105°C ⁽⁴⁾	-	0.01	0.10		
Line Regulation1	ΔV _{OUT} / (ΔV _{IN} · V _{OUT})	V _{OUT(T)} +2.0V ≤ V _{IN} ≤ 28.0V I _{OUT} =5mA, V _{CE} =V _{IN}	-	0.05	0.10	%/V	①
Line Regulation2	ΔV _{OUT} / (ΔV _{IN} · V _{OUT})	V _{OUT(T)} +2.0V ≤ V _{IN} ≤ 28.0V I _{OUT} =13mA, V _{CE} =V _{IN}	-	0.15	0.30	%/V	①
Input Voltage	V _{IN}	-40°C ≤ Ta ≤ 105°C ⁽⁴⁾	2.0	-	28.0	V	-
Output Voltage Temperature Characteristics	ΔV _{OUT} / (ΔTopr · V _{OUT})	I _{OUT} =20mA, V _{CE} =V _{IN} -40°C ≤ Topr ≤ 105°C	-	±100	-	ppm/°C	①
Power Supply Rejection Ratio	PSRR	V _{IN} =[V _{OUT(T)} +2.0]V+0.5V _{P-PAC} I _{OUT} =20mA, f=1kHz, V _{CE} =V _{IN}	-	30	-	dB	③
Short Current	I _{SHORT}	V _{CE} =V _{IN} , V _{OUT} =V _{SS}	-	30	-	mA	①
CE "H" Level Voltage	V _{CEH}	-40°C ≤ Ta ≤ 105°C ⁽⁴⁾	1.1	-	28.0	V	④
CE "L" Level Voltage	V _{CEL}	-40°C ≤ Ta ≤ 105°C ⁽⁴⁾	V _{SS}	-	0.35	V	④
CE "H" Level Current	I _{CEH}	V _{IN} =V _{CE} =28.0V	-0.1	-	0.1	μA	②
		-40°C ≤ Ta ≤ 105°C ⁽⁴⁾	-0.1	-	0.2		
CE "L" Level Current	I _{CEL}	V _{IN} =28.0V V _{CE} =V _{SS} , -40°C ≤ Ta ≤ 105°C ⁽⁴⁾	-0.1	-	0.1	μA	②
Thermal Shutdown Detect Temperature	T _{TSD}	V _{CE} =V _{IN} , Junction Temperature	-	150	-	°C	④
Thermal Shutdown Release Temperature	T _{TSR}	V _{CE} =V _{IN} , Junction Temperature	-	125	-	°C	④
Thermal Shutdown Hysteresis Width	T _{TSD} -T _{TSR}	V _{CE} =V _{IN} , Junction Temperature	-	25	-	°C	-

Unless otherwise stated, (V_{IN}=V_{OUT(T)}+2.0V).

NOTE:

(1): V_{OUT(T)}: Nominal output voltage

(2): V_{OUT(E)}: Effective output voltage

(i.e. the output voltage when "V_{OUT(T)}+2.0V" is provided at the V_{IN} pin while maintaining a certain I_{OUT} value.)

(3): V_{dif}= {V_{IN1} - V_{OUT1}}

V_{OUT1}: V_{OUT(T)}<3.0V, A voltage equal to 98% of the output voltage whenever an amply stabilized I_{OUT}{V_{OUT(T)}+3.0V} is input.

V_{OUT1}: V_{OUT(T)}≥3.0V, A voltage equal to 98% of the output voltage whenever an amply stabilized I_{OUT}{V_{OUT(T)}+2.0V} is input.

V_{IN1}: The input voltage when V_{OUT1} appears as input voltage is gradually decreased.

(4): The ambient temperature range (-40°C ≤ Ta ≤ 105°C) is design Value.

■ ELECTRICAL CHARACTERISTICS (Continued)

● Voltage Chart1 (XD6216 Series)

PARAMETER	E-0				E-1		E-2	
	Output Voltage (V)		Output Voltage (V)		DROPOUT VOLTAGE 1 (mV) $I_{OUT}=20mA$		DROPOUT VOLTAGE 2 (mV) $I_{OUT}=100mA$	
NOMINAL OUTPUT VOLTAGE(V)	$T_a=25^{\circ}C$		$-40^{\circ}C \leq T_a \leq 105^{\circ}C$		$T_a=25^{\circ}C$		$T_a=25^{\circ}C$	
$V_{OUT(T)}$	$V_{OUT(E)}$		$V_{OUT(E)}$		V_{dif1}		V_{dif2}	
	MIN	MAX	MIN	MAX	TYP	MAX	TYP	MAX
1.8	1.780	1.820	1.740	1.860	550	710	2200	2700
1.9	1.880	1.920	1.840	1.960				
2.0	1.980	2.020	1.940	2.060	450	600	1900	2600
2.1	2.079	2.121	2.037	2.163				
2.2	2.178	2.222	2.134	2.266	390	520	1700	2200
2.3	2.277	2.323	2.231	2.369				
2.4	2.376	2.424	2.328	2.472				
2.5	2.475	2.525	2.425	2.575				
2.6	2.574	2.626	2.522	2.678	310	450	1500	1900
2.7	2.673	2.727	2.619	2.781				
2.8	2.772	2.828	2.716	2.884				
2.9	2.871	2.929	2.813	2.987				
3.0	2.970	3.030	2.910	3.090				
3.1	3.069	3.131	3.007	3.193				
3.2	3.168	3.232	3.104	3.296	260	360	1300	1700
3.3	3.267	3.333	3.201	3.399				
3.4	3.366	3.434	3.298	3.502				
3.5	3.465	3.535	3.395	3.605				
3.6	3.564	3.636	3.492	3.708				
3.7	3.663	3.737	3.589	3.811				
3.8	3.762	3.838	3.686	3.914				
3.9	3.861	3.939	3.783	4.017				
4.0	3.960	4.040	3.880	4.120				
4.1	4.059	4.141	3.977	4.223				
4.2	4.158	4.242	4.074	4.326				
4.3	4.257	4.343	4.171	4.429				
4.4	4.356	4.444	4.268	4.532				
4.5	4.455	4.545	4.365	4.635				
4.6	4.554	4.646	4.462	4.738				
4.7	4.653	4.747	4.559	4.841				
4.8	4.752	4.848	4.656	4.944				
4.9	4.851	4.949	4.753	5.047				

ELECTRICAL CHARACTERISTICS (Continued)

● Voltage Chart1 (XD6216 Series) (Continued)

PARAMETER	E-0				E-1		E-2	
NOMINAL OUTPUT VOLTAGE(V)	Output Voltage (V)		Output Voltage (V)		DROPOUT VOLTAGE 1 (mV) $I_{OUT}=20mA$		DROPOUT VOLTAGE 2 (mV) $I_{OUT}=100mA$	
	$T_a=25^{\circ}C$		$-40^{\circ}C \leq T_a \leq 105^{\circ}C$		$T_a=25^{\circ}C$		$T_a=25^{\circ}C$	
$V_{OUT(T)}$	$V_{OUT(E)}$		$V_{OUT(E)}$		V_{dif1}		V_{dif2}	
	MIN	MAX	MIN	MAX	TYP	MAX	TYP	MAX
5.0	4.950	5.050	4.850	5.150	190	280	1000	1300
5.1	5.049	5.151	4.947	5.253				
5.2	5.148	5.252	5.044	5.356				
5.3	5.247	5.353	5.141	5.459				
5.4	5.346	5.454	5.238	5.562				
5.5	5.445	5.555	5.335	5.665				
5.6	5.544	5.656	5.432	5.768				
5.7	5.643	5.757	5.529	5.871				
5.8	5.742	5.858	5.626	5.974				
5.9	5.841	5.959	5.723	6.077				
6.0	5.940	6.060	5.820	6.180				
6.1	6.039	6.161	5.917	6.283				
6.2	6.138	6.262	6.014	6.386				
6.3	6.237	6.363	6.111	6.489				
6.4	6.336	6.464	6.208	6.592				
6.5	6.435	6.565	6.305	6.695	170	230	800	1150
6.6	6.534	6.666	6.402	6.798				
6.7	6.633	6.767	6.499	6.901				
6.8	6.732	6.868	6.596	7.004				
6.9	6.831	6.969	6.693	7.107				
7.0	6.930	7.070	6.790	7.210				
7.1	7.029	7.171	6.887	7.313				
7.2	7.128	7.272	6.984	7.416				
7.3	7.227	7.373	7.081	7.519				
7.4	7.326	7.474	7.178	7.622				
7.5	7.425	7.575	7.275	7.725				
7.6	7.524	7.676	7.372	7.828				
7.7	7.623	7.777	7.469	7.931				
7.8	7.722	7.878	7.566	8.034				
7.9	7.821	7.979	7.663	8.137				
8.0	7.920	8.080	7.760	8.240				

■ ELECTRICAL CHARACTERISTICS (Continued)

● Voltage Chart1 (XD6216 Series) (Continued)

PARAMETER	E-0				E-1		E-2	
NOMINAL OUTPUT VOLTAGE(V)	Output Voltage (V)		Output Voltage (V)		DROPOUT VOLTAGE 1 (mV) $I_{OUT}=20mA$		DROPOUT VOLTAGE 2 (mV) $I_{OUT}=100mA$	
	Ta=25°C		-40°C ≤ Ta ≤ 105°C		Ta=25°C		Ta=25°C	
V _{OUT(T)}	V _{OUT(E)}		V _{OUT(E)}		V _{dif1}		V _{dif2}	
	MIN	MAX	MIN	MAX	TYP	MAX	TYP	MAX
8.1	8.019	8.181	7.857	8.343	130	190	700	950
8.2	8.118	8.282	7.954	8.446				
8.3	8.217	8.383	8.051	8.549				
8.4	8.316	8.484	8.148	8.652				
8.5	8.415	8.585	8.245	8.755				
8.6	8.514	8.686	8.342	8.858				
8.7	8.613	8.787	8.439	8.961				
8.8	8.712	8.888	8.536	9.064				
8.9	8.811	8.989	8.633	9.167				
9.0	8.910	9.090	8.730	9.270				
9.1	9.009	9.191	8.827	9.373				
9.2	9.108	9.292	8.924	9.476				
9.3	9.207	9.393	9.021	9.579				
9.4	9.306	9.494	9.118	9.682				
9.5	9.405	9.595	9.215	9.785				
9.6	9.504	9.696	9.312	9.888				
9.7	9.603	9.797	9.409	9.991				
9.8	9.702	9.898	9.506	10.094				
9.9	9.801	9.999	9.603	10.197				
10.0	9.900	10.100	9.700	10.300				
10.1	9.999	10.201	9.797	10.403	120	160	650	850
10.2	10.098	10.302	9.894	10.506				
10.3	10.197	10.403	9.991	10.609				
10.4	10.296	10.504	10.088	10.712				
10.5	10.395	10.605	10.185	10.815				
10.6	10.494	10.706	10.282	10.918				
10.7	10.593	10.807	10.379	11.021				
10.8	10.692	10.908	10.476	11.124				
10.9	10.791	11.009	10.573	11.227				
11.0	10.890	11.110	10.670	11.330				
11.1	10.989	11.211	10.767	11.433				
11.2	11.088	11.312	10.864	11.536				
11.3	11.187	11.413	10.961	11.639				
11.4	11.286	11.514	11.058	11.742				
11.5	11.385	11.615	11.155	11.845				
11.6	11.484	11.716	11.252	11.948				
11.7	11.583	11.817	11.349	12.051				
11.8	11.682	11.918	11.446	12.154				
11.9	11.781	12.019	11.543	12.257				
12.0	11.880	12.120	11.640	12.360				

TEST CIRCUITS

●CIRCUIT①

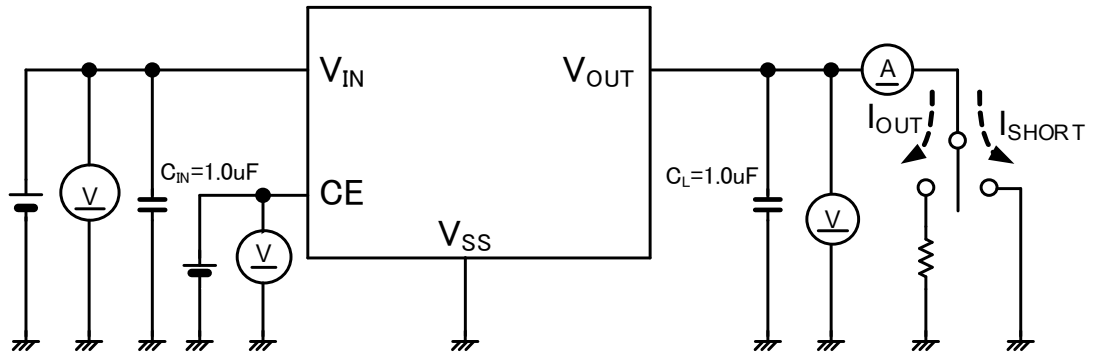

●CIRCUIT②

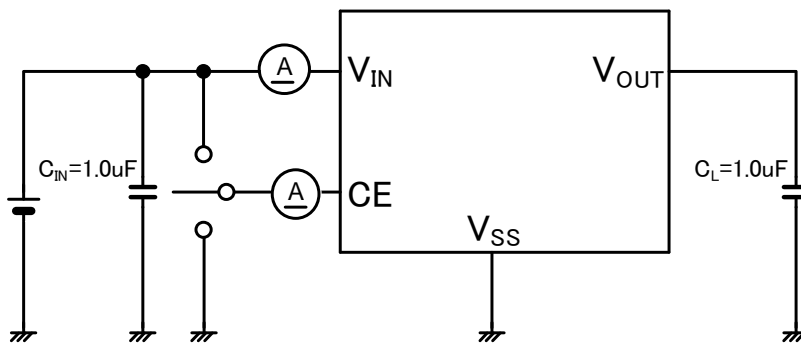

●CIRCUIT③

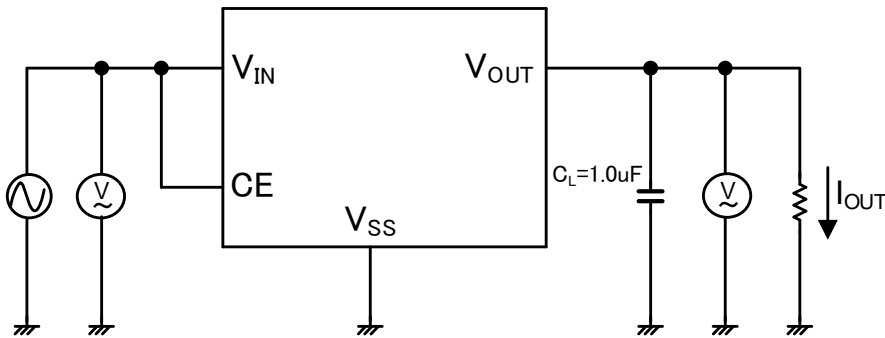

●CIRCUIT④

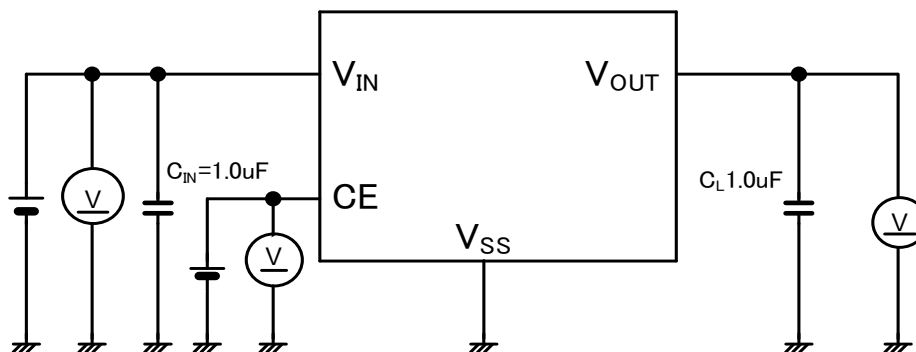

OPERATIONAL EXPLANATION

The voltage divided by resistors R_1 & R_2 is compared with the internal voltage reference by the error amplifier. The P-channel MOSFET which is connected to the V_{OUT} pin is then driven by the subsequent controlled signal. The output voltage at the V_{OUT} pin is controlled and stabilized by a system of negative feedback. The current limit circuit and short protect circuit operate in relation to the level of output current and heat dissipation. Further, the IC's internal circuitry can be shutdown via the CE pin's signal.

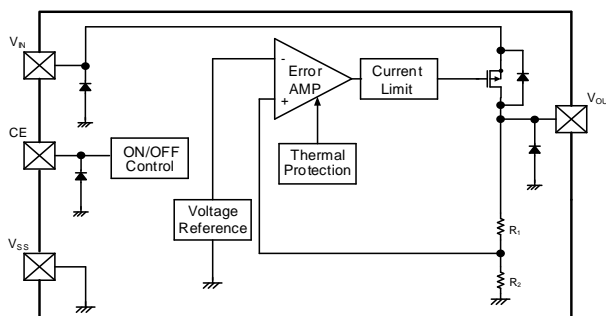

* Diodes shown in the above circuit are ESD protection diodes and parasitic diodes

<Low ESR Capacitors>

The XD6216 series needs an output capacitor (C_L) for phase compensation. In order to ensure the stable phase compensation, please place an output capacitor (C_L) of 1.0 μ F or bigger at the V_{OUT} pin and V_{SS} pin as close as possible. For a stable power input, please connect an input capacitor (C_{IN}) of 1.0 μ F between the input pin (V_{IN}) and the ground pin (V_{SS}). Since Input capacitor (C_{IN}), the output capacitor (C_L) are bias dependence of the capacitor the influence of the missing capacity due to temperature characteristics, also there is a risk that cannot be stable phase compensation. Please pay attention to the selection of the capacitor to be used.

<Current limit Protection>

The XD6216 series includes a current fold-back circuit as a current limit protection. When the load current reaches the current limit level, the current fold-back circuit operates and output voltage drops. The output voltage drops further and output current decreases. When the output pin is shorted, a current of about 30mA flows.

<CE Pin>

The IC's internal circuitry can be stand-by via the signal from the CE pin. In stand-by mode, output at the V_{OUT} pin will be pulled down by R_1 and R_2 to the V_{SS} level. Note that as the XD6216 series has no pull down resistor so that it will become unstable with the CE pin open. We suggest that you use this IC with either a V_{IN} voltage or a V_{SS} voltage input at the CE pin. If this IC is used with the correct specifications for the CE pin, the operational logic is fixed and the IC will operate normally. However, supply current may increase as a result of through current in the IC's internal circuitry if a medium voltage is applied.

<Overheating Protection (Thermal Protection)>

The XD6216 series incorporates a thermal shutdown circuit for overheating protection. When the junction temperature of the built-in driver transistor reaches the temperature limit, the thermal shutdown circuit operates and the driver transistor will be set to OFF. The IC resumes its operation when the thermal shutdown function is released and the IC's operation is automatically restored because the junction temperature drops to the level of the thermal shutdown release temperature.

<Minimum Operating Voltage>

For the stable operation of the IC, over 2.0V of input voltage is necessary. The output voltage may not be generated normally if the input voltage is less than 2.0V.

NOTES ON USE

1. For temporary, transitional voltage drop or voltage rising phenomenon, the IC is liable to malfunction should the ratings be exceeded.
2. Where wiring impedance is high, operations may become unstable due to noise and/or phase lag depending on output current. Please strengthen V_{IN} and V_{SS} wiring in particular. The input capacitor (C_{IN}) and the output capacitor (C_L) should be placed to the IC as close as possible with a shorter wiring.
3. Torex places an importance on improving our products and its reliability. However, by any possibility, we would request user fail-safe design and post-aging treatment on system or equipment.

TYPICAL PERFORMANCE CHARACTERISTICS

(1) Output Voltage vs. Output Current

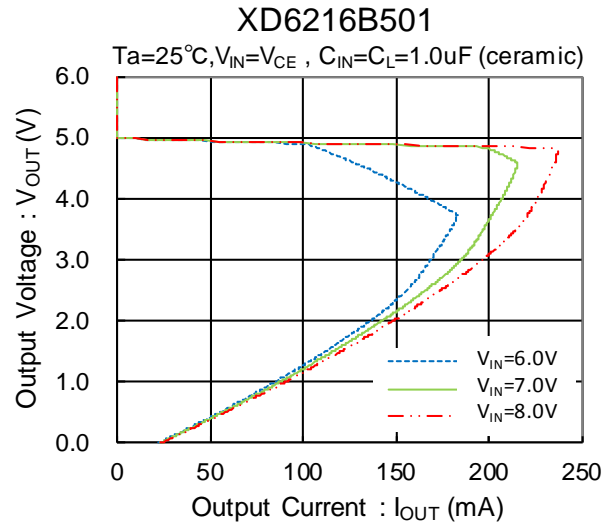
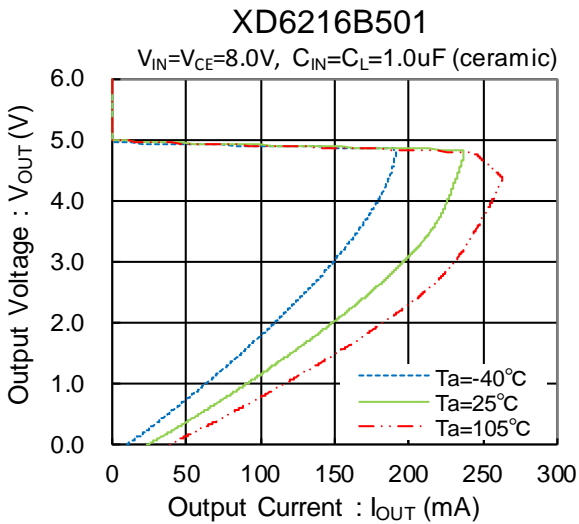
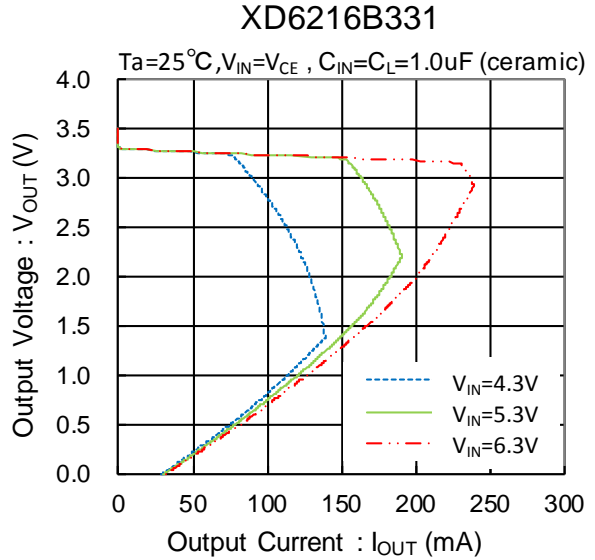
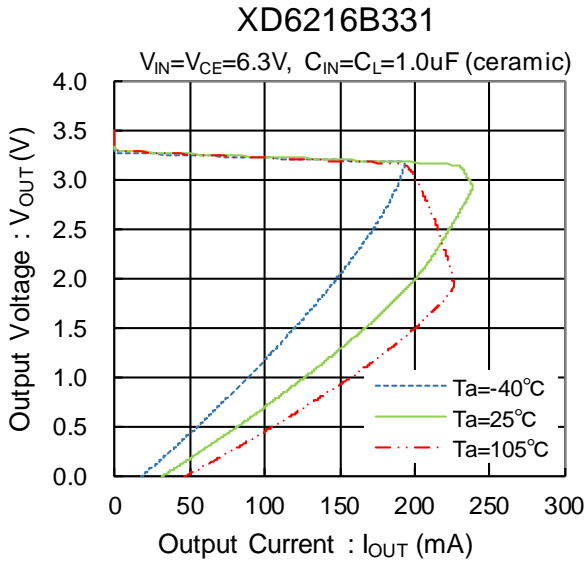

(2) Output Voltage vs. Input Voltage

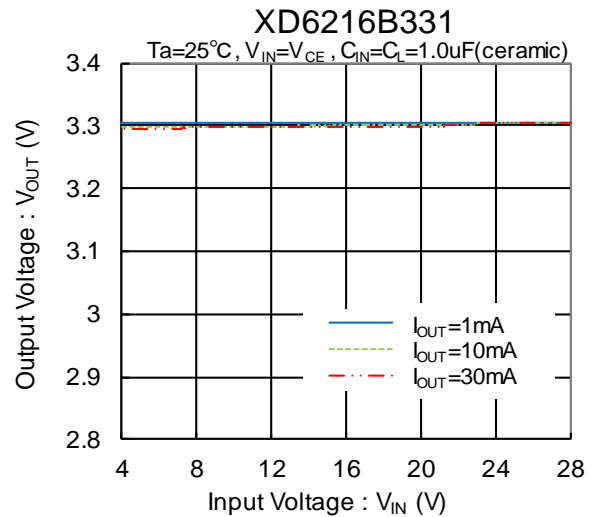

■ TYPICAL PERFORMANCE CHARACTERISTICS (Continued)

(2) Output Voltage vs. Input Voltage (Continued)

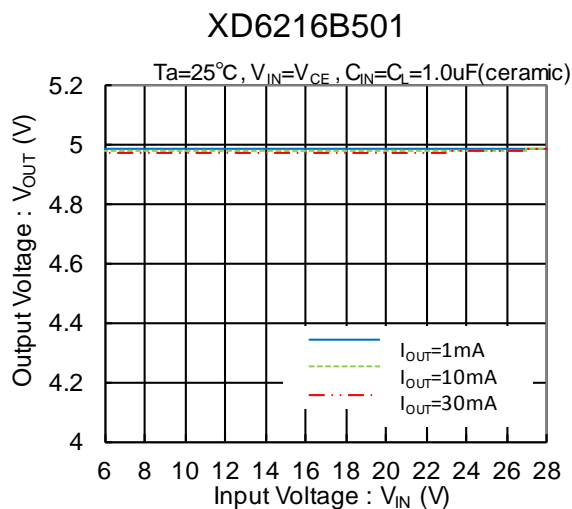

(3) Dropout Voltage vs. Output Current

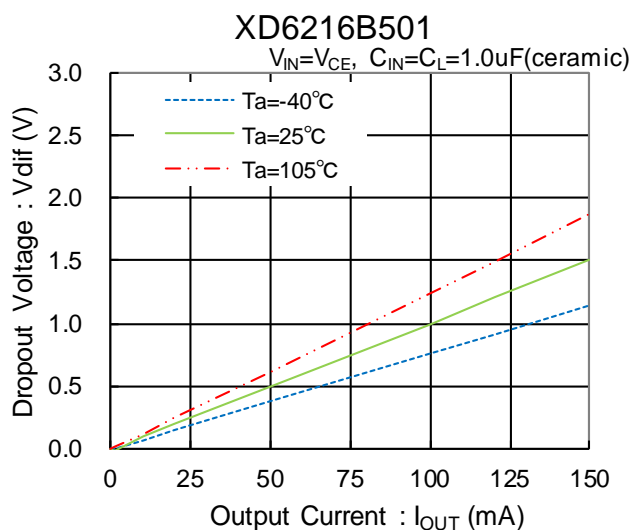
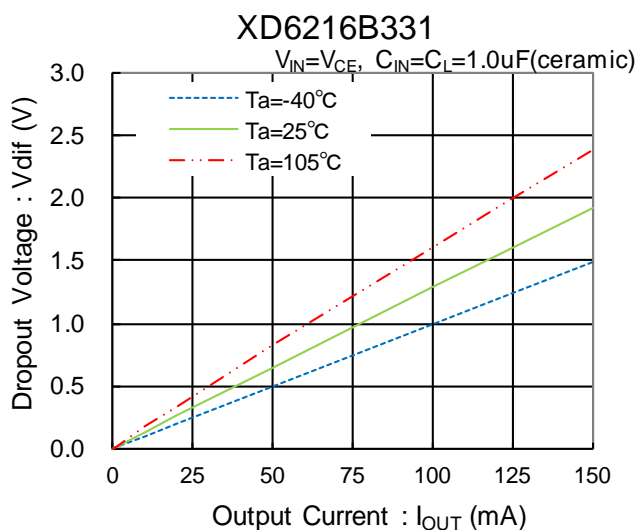

(4) Supply Current vs. Input Voltage

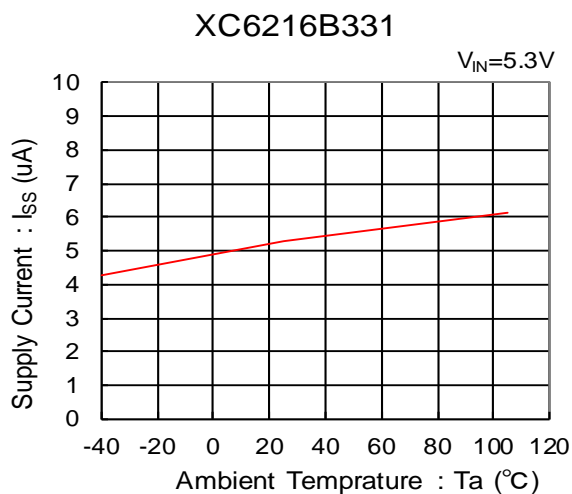
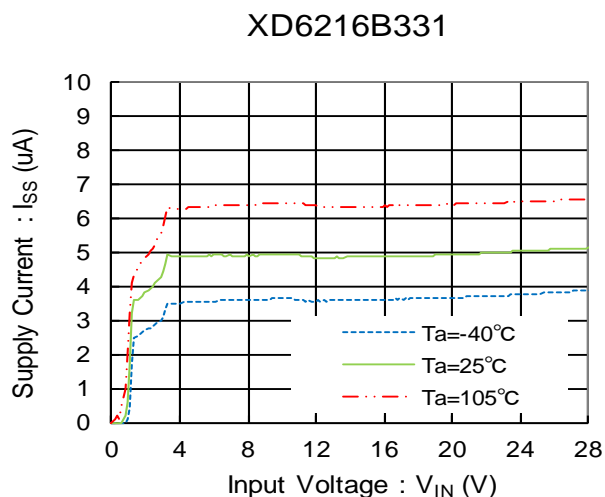

TYPICAL PERFORMANCE CHARACTERISTICS (Continued)

(4) Supply Current vs. Input Voltage (Continued)

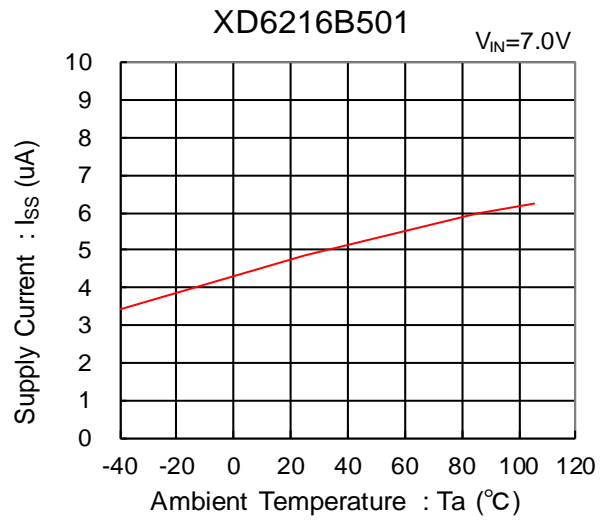
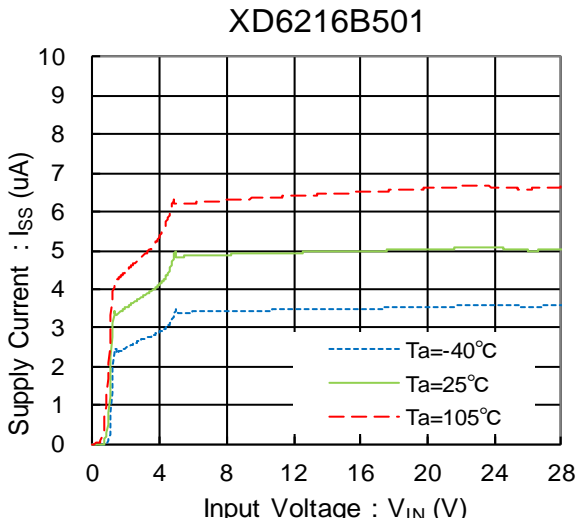

(5) Output Voltage vs. Ambient Temperature

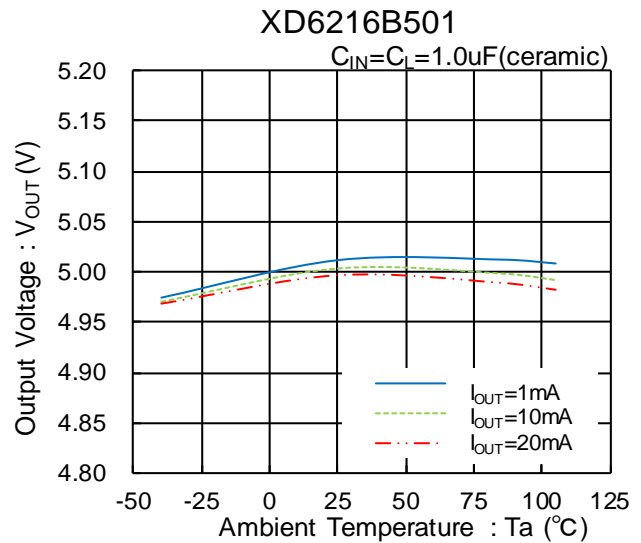
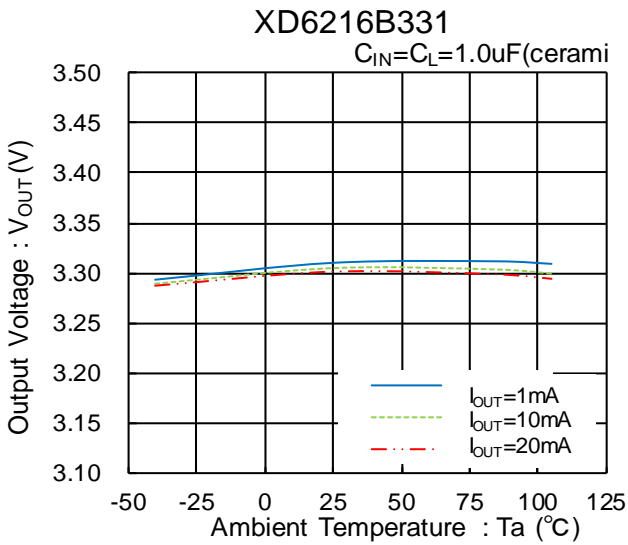

(6) Line Transient Response

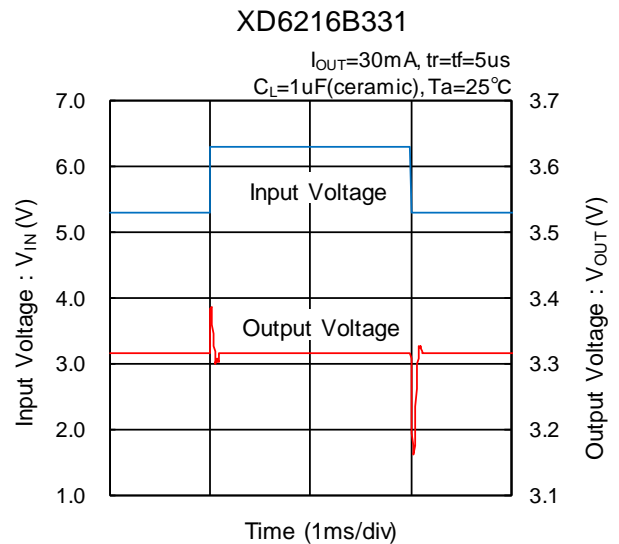
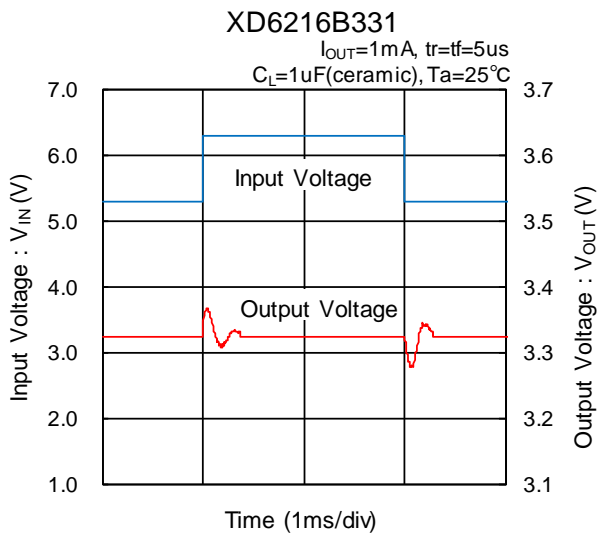

■ TYPICAL PERFORMANCE CHARACTERISTICS (Continued)

(6) Line Transient Response (Continued)

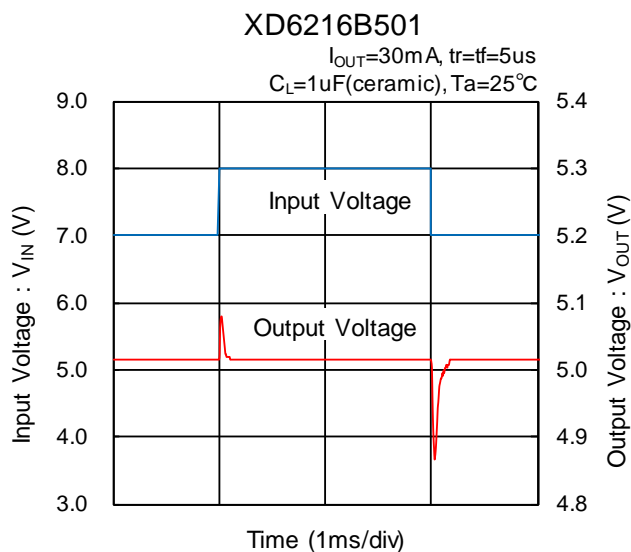

(7) Load Transient Response

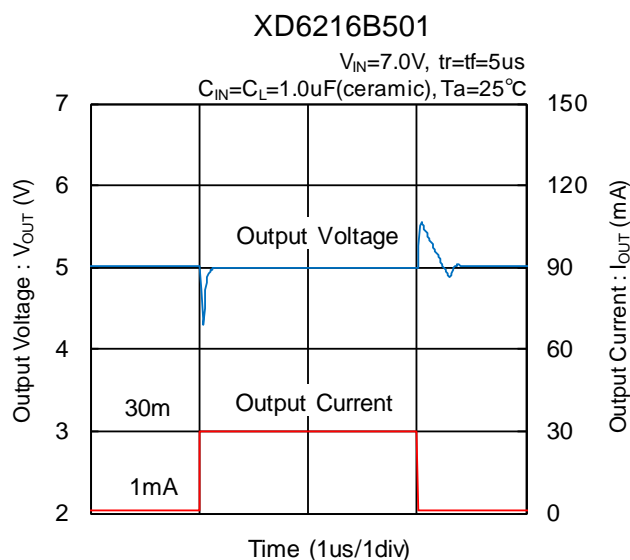
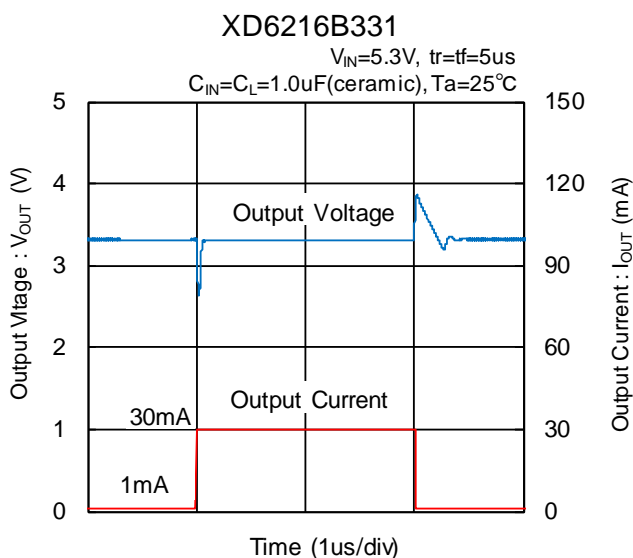

(8) Input Rise Time



TYPICAL PERFORMANCE CHARACTERISTICS (Continued)

(8) Input Rise Time (Continued)

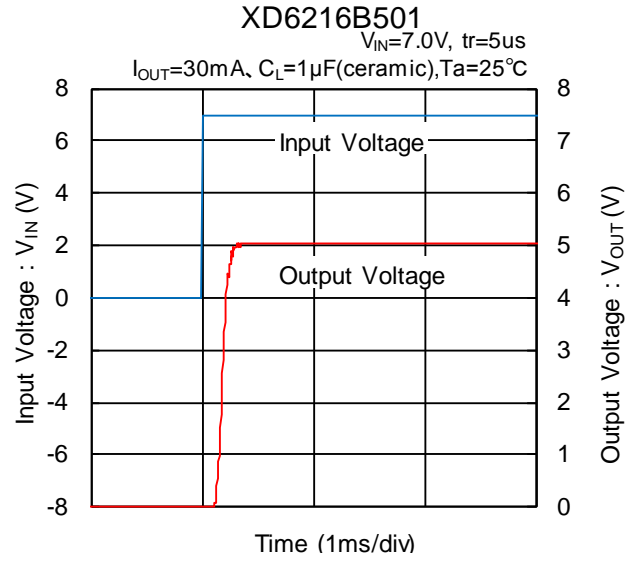
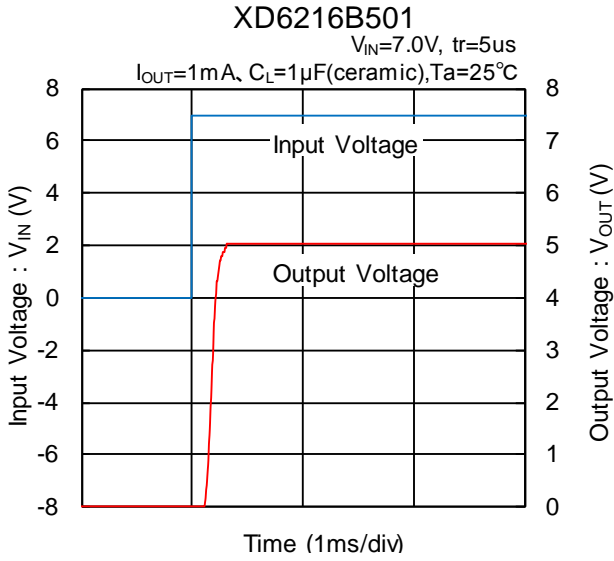

(9) CE Rise Time

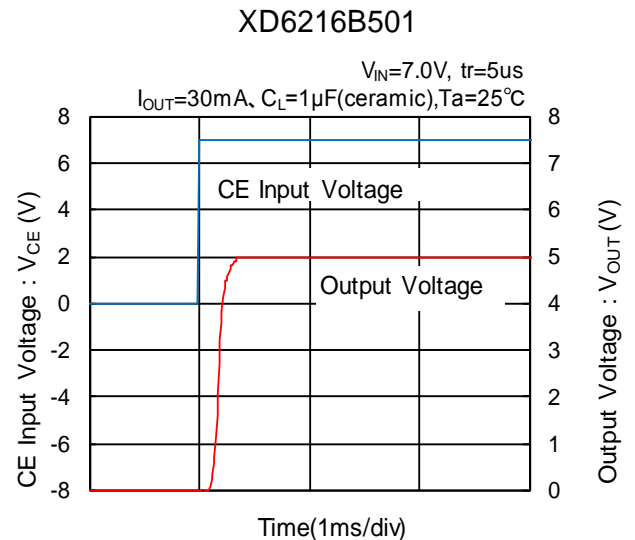
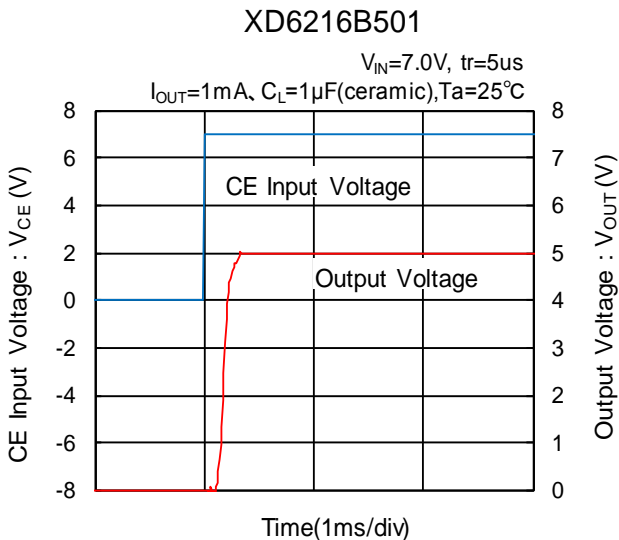
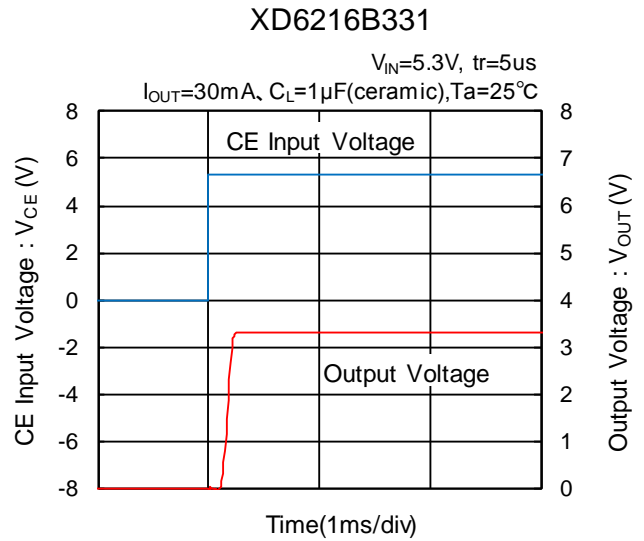
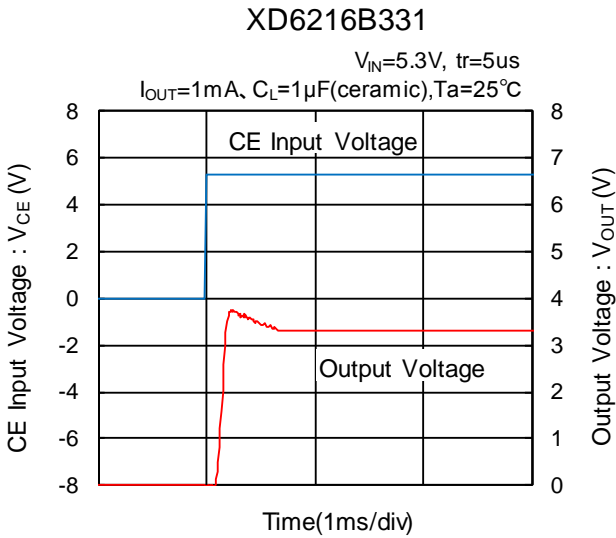

■ **TYPICAL PERFORMANCE CHARACTERISTICS (Continued)**

(10) Ripple Rejection Rate

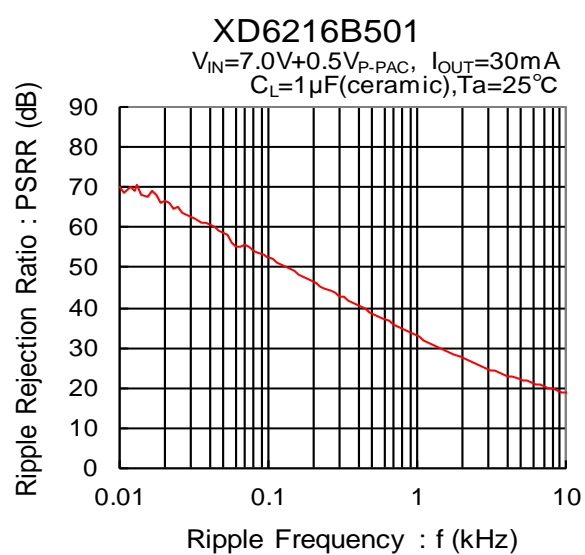
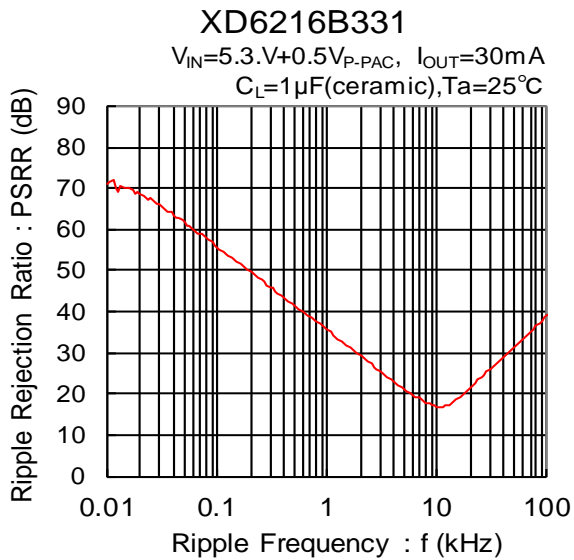
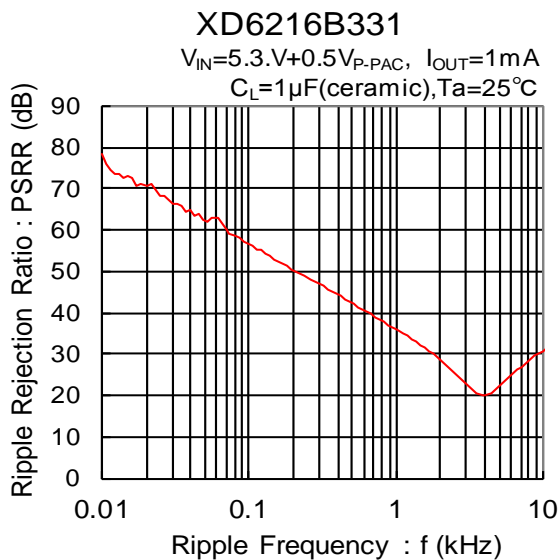

■ PACKAGING INFORMATION

For the latest package information go to, www.torexsemi.com/technical-support/packages

PACKAGE	OUTLINE / LAND PATTERN	THERMAL CHARACTERISTICS	
SOT-25	SOT-25 PKG	Standard Board	SOT-25 Power Dissipation
		JESD51-7 Board	
SOT-89-5	SOT-89-5 PKG	Standard Board	SOT-89-5 Power Dissipation
		JESD51-7 Board	

MARKING RULE

● SOT-25 / SOT-89-5

SOT-89-5

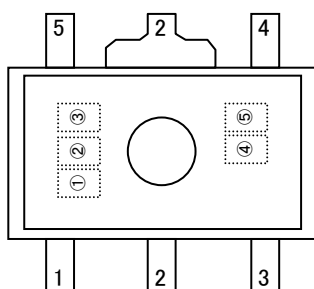

SOT-25(Under dot)

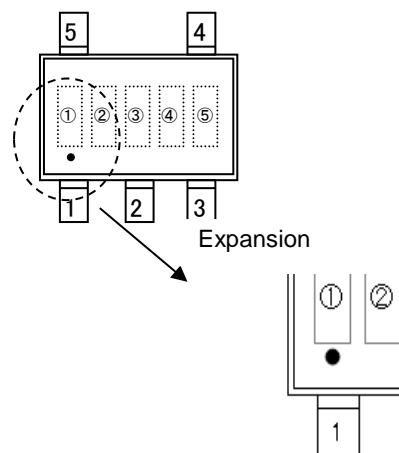

① represents the product series

MARK	VOLTAGE (V)
K	XD6216****M*-Q
M	XD6216****P*-Q

*MARK "K" is to be Under dot.

② represents the output voltage range

MARK	Type	VOLTAGE (V)	PRODUCT SERIES
0	with CE function	1.8~3.0	XD6216B*****-Q
1		3.1~6.0	
2		6.1~9.0	
3		9.1~12.0	

③ represents the output voltage

MARK	VOLTAGE(V)			MARK	VOLTAGE(V)				
0	-	3.1	6.1	9.1	F	-	4.6	7.6	10.6
1	-	3.2	6.2	9.2	H	-	4.7	7.7	10.7
2	-	3.3	6.3	9.3	K	1.8	4.8	7.8	10.8
3	-	3.4	6.4	9.4	L	1.9	4.9	7.9	10.9
4	-	3.5	6.5	9.5	M	2.0	5.0	8.0	11.0
5	-	3.6	6.6	9.6	N	2.1	5.1	8.1	11.1
6	-	3.7	6.7	9.7	P	2.2	5.2	8.2	11.2
7	-	3.8	6.8	9.8	R	2.3	5.3	8.3	11.3
8	-	3.9	6.9	9.9	S	2.4	5.4	8.4	11.4
9	-	4.0	7.0	10.0	T	2.5	5.5	8.5	11.5
A	-	4.1	7.1	10.1	U	2.6	5.6	8.6	11.6
B	-	4.2	7.2	10.2	V	2.7	5.7	8.7	11.7
C	-	4.3	7.3	10.3	X	2.8	5.8	8.8	11.8
D	-	4.4	7.4	10.4	Y	2.9	5.9	8.9	11.9
E	-	4.5	7.5	10.5	Z	3.0	6.0	9.0	12.0

④,⑤ represents assembly lot number

01 to 09, 0A to 0Z, 11 to 9Z, A1 to A9, AA to AZ, B1 to ZZ repeated (G, I, J, O, Q, W excluded)

Note: No character inversion used.

1. The product and product specifications contained herein are subject to change without notice to improve performance characteristics. Consult us, or our representatives before use, to confirm that the information in this datasheet is up to date.
2. The information in this datasheet is intended to illustrate the operation and characteristics of our products. We neither make warranties or representations with respect to the accuracy or completeness of the information contained in this datasheet nor grant any license to any intellectual property rights of ours or any third party concerning with the information in this datasheet.
3. Applicable export control laws and regulations should be complied and the procedures required by such laws and regulations should also be followed, when the product or any information contained in this datasheet is exported.
4. The product is neither intended nor warranted for use in equipment of systems which require extremely high levels of quality and/or reliability and/or a malfunction or failure which may cause loss of human life, bodily injury, serious property damage including but not limited to devices or equipment used in 1) nuclear facilities, 2) aerospace industry, 3) medical facilities, 4) automobile industry and other transportation industry and 5) safety devices and safety equipment to control combustions and explosions, excluding when specified for in-vehicle use or other uses.
Do not use the product for in-vehicle use or other uses unless agreed by us in writing in advance.
5. Although we make continuous efforts to improve the quality and reliability of our products; nevertheless Semiconductors are likely to fail with a certain probability. So in order to prevent personal injury and/or property damage resulting from such failure, customers are required to incorporate adequate safety measures in their designs, such as system fail safes, redundancy and fire prevention features.
6. Our products are not designed to be Radiation-resistant.
7. Please use the product listed in this datasheet within the specified ranges.
8. We assume no responsibility for damage or loss due to abnormal use.
9. All rights reserved. No part of this datasheet may be copied or reproduced unless agreed by Torex Semiconductor Ltd in writing in advance.

TOREX SEMICONDUCTOR LTD.

X-ON Electronics

Largest Supplier of Electrical and Electronic Components

Click to view similar products for [LDO Voltage Regulators](#) category:

Click to view products by [Torex Semiconductor](#) manufacturer:

Other Similar products are found below :

[L79M05TL-E](#) [PT7M8202B12TA5EX](#) [TCR3DF185,LM\(CT](#) [TCR3DF24,LM\(CT](#) [TCR3DF285,LM\(CT](#) [TCR3DF31,LM\(CT](#)
[TCR3DF45,LM\(CT](#) [MP2013GQ-33-Z](#) [059985X](#) [NCP4687DH15T1G](#) [701326R](#) [TCR2EN28,LF\(S](#) [NCV8170AXV250T2G](#)
[TCR3DF27,LM\(CT](#) [TCR3DF19,LM\(CT](#) [TCR3DF125,LM\(CT](#) [TCR2EN18,LF\(S](#) [AP2112R5A-3.3TRG1](#) [AP7315-25W5-7](#)
[IFX30081LDVGRNXUMA1](#) [AP2113KTR-G1](#) [AP2111H-1.2TRG1](#) [ZLDO1117QK50TC](#) [AZ1117ID-ADJTRG1](#) [TCR3DG12,LF](#) [MIC5514-](#)
[3.3YMT-T5](#) [MIC5512-1.2YMT-T5](#) [MIC5317-2.8YM5-T5](#) [SCD7912BTG](#) [NCP154MX180270TAG](#) [SCD33269T-5.0G](#)
[NCV8170BMX330TCG](#) [NCV8170AMX120TCG](#) [NCP706ABMX300TAG](#) [NCP153MX330180TCG](#) [NCP114BMX075TCG](#) [MC33269T-3.5G](#)
[CAT6243-ADJCMT5T](#) [TCR3DG33,LF](#) [AP2127N-1.0TRG1](#) [TCR4DG35,LF](#) [LT1117CST-3.3](#) [TAR5S15U\(TE85L,F\)](#) [TAR5S18U\(TE85L,F\)](#)
[TCR3UG19A,LF](#) [TCR4DG105,LF](#) [NCV8170AMX360TCG](#) [MIC94310-NYMT-T5](#) [NCV4266-2CST33T3G](#) [NCV8186BMN175TAG](#)