

74VHCT14AFT

1. Functional Description

- Hex Schmitt Inverter

2. General

The 74VHCT14AFT is an advanced high speed CMOS SCHMITT INVERTER fabricated with silicon gate C²MOS technology.

It achieves the high speed operation similar to equivalent Bipolar Schottky TTL while maintaining the CMOS low power dissipation.

Pin configuration and function are the same as the 74VHC04FT but the inputs have hysteresis and with its schmitt trigger function, the 74VHCT14AFT can be used as a line receivers which will receive slow input signals. The input voltage are compatible with TTL output voltage.

This device may be used as a level converter for interfacing 3.3 V to 5 V system.

Input protection and output circuit ensure that 0 to 5.5 V can be applied to the input and output (Note) pins without regard to the supply voltage. These structure prevents device destruction due to mismatched supply and input/output voltages such as battery back up, hot board insertion, etc.

Note: $V_{CC} = 0\text{ V}$

3. Features

- (1) AEC-Q100 (Rev. H) (Note 1)
- (2) Wide operating temperature range: $T_{opr} = -40\text{ to }125\text{ }^{\circ}\text{C}$
- (3) High speed: $t_{pd} = 5.0\text{ ns}$ (typ.) at $V_{CC} = 5.0\text{ V}$
- (4) Low power dissipation: $I_{CC} = 2.0\text{ }\mu\text{A}$ (max) at $T_a = 25\text{ }^{\circ}\text{C}$
- (5) Compatible with TTL inputs : $V_{IL} = 0.5\text{ V}$ (max)
: $V_{IH} = 2.1\text{ V}$ (min)
- (6) Power down protection is provided on all inputs and outputs.
- (7) Balanced propagation delays: $t_{PLH} \approx t_{PHL}$
- (8) Low noise: $V_{OLP} = 0.8\text{ V}$ (max)
- (9) Pin and function compatible with the 74 series (AC/HC/AHC/LV etc.) 14 type.

Note 1: This device is compliant with the reliability requirements of AEC-Q100. For details, contact your Toshiba sales representative.

4. Packaging

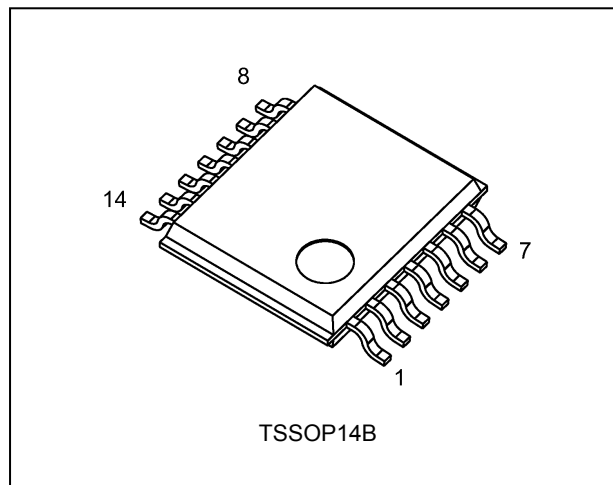

Start of commercial production

2014-10

5. Pin Assignment

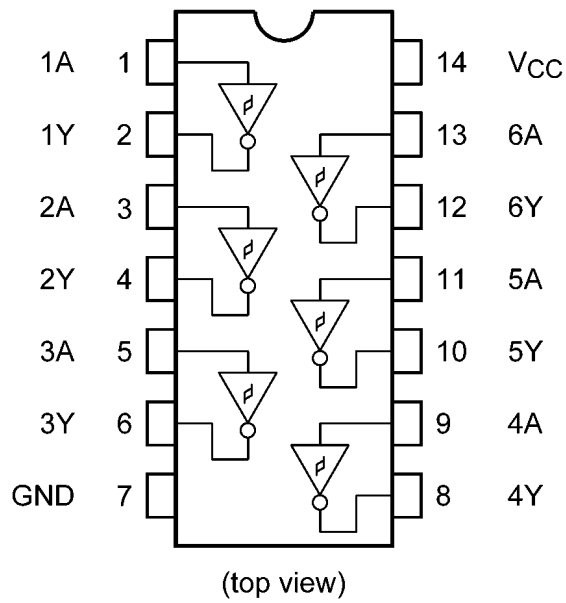

6. Marking

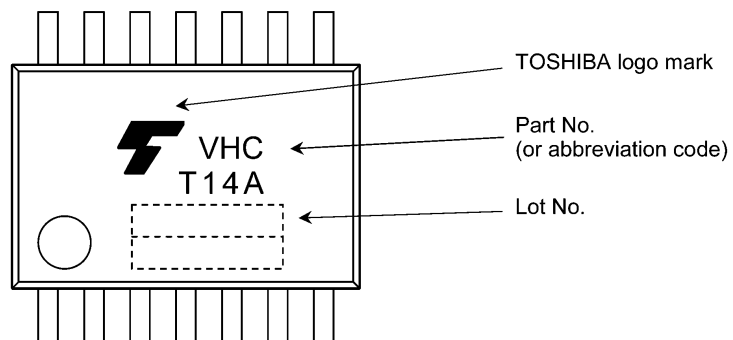

7. IEC Logic Symbol

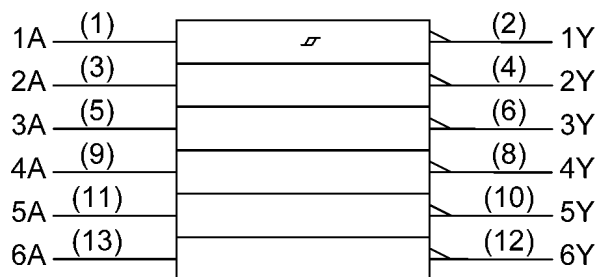

8. Truth Table

A	Y
L	H
H	L

9. System Diagram, Waveform

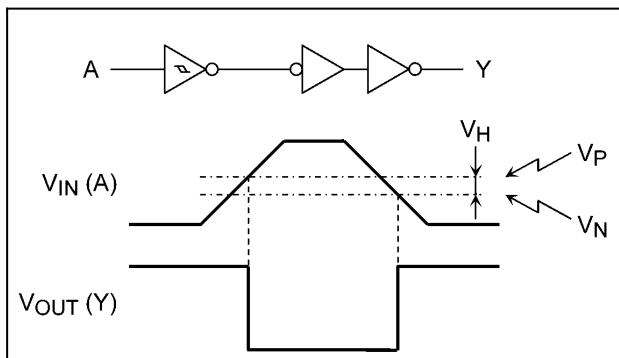

10. Absolute Maximum Ratings (Note)

Characteristics	Symbol	Note	Rating	Unit
Supply voltage	V_{CC}		-0.5 to 7.0	V
Input voltage	V_{IN}		-0.5 to 7.0	V
Output voltage	V_{OUT}	(Note 1)	-0.5 to 7.0	V
		(Note 2)	-0.5 to $V_{CC} + 0.5$	
Input diode current	I_{IK}		-20	mA
Output diode current	I_{OK}	(Note 3)	± 20	mA
Output current	I_{OUT}		± 25	mA
V_{CC} /ground current	I_{CC}		± 50	mA
Power dissipation	P_D	(Note 4)	180	mW
Storage temperature	T_{stg}		-65 to 150	$^{\circ}C$

Note: Exceeding any of the absolute maximum ratings, even briefly, lead to deterioration in IC performance or even destruction.

Using continuously under heavy loads (e.g. the application of high temperature/current/voltage and the significant change in temperature, etc.) may cause this product to decrease in the reliability significantly even if the operating conditions (i.e. operating temperature/current/voltage, etc.) are within the absolute maximum ratings and the operating ranges.

Please design the appropriate reliability upon reviewing the Toshiba Semiconductor Reliability Handbook (“Handling Precautions”/“Derating Concept and Methods”) and individual reliability data (i.e. reliability test report and estimated failure rate, etc).

Note 1: $V_{CC} = 0$ V

Note 2: High (H) or Low (L) state. I_{OUT} absolute maximum rating must be observed.

Note 3: $V_{OUT} < GND$, $V_{OUT} > V_{CC}$

Note 4: 180 mW in the range of $T_a = -40$ to 85 $^{\circ}C$. From $T_a = 85$ to 125 $^{\circ}C$ a derating factor of -3.25 mW/ $^{\circ}C$ shall be applied until 50 mW.

11. Operating Ranges (Note)

Characteristics	Symbol	Note	Rating	Unit
Supply voltage	V_{CC}		4.5 to 5.5	V
Input voltage	V_{IN}		0 to 5.5	V
Output voltage	V_{OUT}	(Note 1)	0 to 5.5	V
		(Note 2)	0 to V_{CC}	
Operating temperature	T_{opr}		-40 to 125	°C

Note: The operating ranges must be maintained to ensure the normal operation of the device.

Unused inputs must be tied to either V_{CC} or GND.

Note 1: $V_{CC} = 0$ V

Note 2: High (H) or Low (L) state.

12. Electrical Characteristics

12.1. DC Characteristics (Unless otherwise specified, $T_a = 25$ °C)

Characteristics	Symbol	Test Condition	V_{CC} (V)	Min	Typ.	Max	Unit
Positive threshold voltage	V_P	—	4.5	—	—	1.90	V
			5.5	—	—	2.10	
Negative threshold voltage	V_N	—	4.5	0.50	—	—	V
			5.5	0.60	—	—	
Hysteresis voltage	V_H	—	4.5	0.40	—	1.40	V
			5.5	0.40	—	1.50	
High-level output voltage	V_{OH}	$V_{IN} = V_{IL}$	$I_{OH} = -50$ μ A	4.5	4.4	4.5	V
			$I_{OH} = -8$ mA	4.5	3.94	—	
Low-level output voltage	V_{OL}	$V_{IN} = V_{IH}$	$I_{OL} = 50$ μ A	4.5	—	0.0	V
			$I_{OL} = 8$ mA	4.5	—	—	
Input leakage current	I_{IN}	$V_{IN} = 5.5$ V or GND	0 to 5.5	—	—	± 0.1	μ A
Quiescent supply current	I_{CC}	$V_{IN} = V_{CC}$ or GND	5.5	—	—	2.0	μ A
	I_{CCT}	Per input: $V_{IN} = 3.4$ V Other input: V_{CC} or GND	5.5	—	—	1.35	mA
Output leakage current (Power-OFF)	I_{OPD}	$V_{OUT} = 5.5$ V	0	—	—	0.5	μ A

12.2. DC Characteristics (Unless otherwise specified, $T_a = -40$ to 85 °C)

Characteristics	Symbol	Test Condition	V_{CC} (V)	Min	Max	Unit	
Positive threshold voltage	V_P	—	4.5	—	1.90	V	
			5.5	—	2.10		
Negative threshold voltage	V_N	—	4.5	0.50	—	V	
			5.5	0.60	—		
Hysteresis voltage	V_H	—	4.5	0.40	1.40	V	
			5.5	0.40	1.50		
High-level output voltage	V_{OH}	$V_{IN} = V_{IL}$	$I_{OH} = -50 \mu A$	4.5	4.4	—	V
			$I_{OH} = -8 \text{ mA}$	4.5	3.80	—	
Low-level output voltage	V_{OL}	$V_{IN} = V_{IH}$	$I_{OL} = 50 \mu A$	4.5	—	0.1	V
			$I_{OL} = 8 \text{ mA}$	4.5	—	0.44	
Input leakage current	I_{IN}	$V_{IN} = 5.5 \text{ V or GND}$	0 to 5.5	—	± 1.0	μA	
Quiescent supply current	I_{CC}	$V_{IN} = V_{CC} \text{ or GND}$	5.5	—	20.0	μA	
	I_{CCT}	Per input: $V_{IN} = 3.4 \text{ V}$ Other input: $V_{CC} \text{ or GND}$	5.5	—	1.50	mA	
Output leakage current (Power-OFF)	I_{OPD}	$V_{OUT} = 5.5 \text{ V}$	0	—	5.0	μA	

12.3. DC Characteristics (Unless otherwise specified, $T_a = -40$ to 125 °C)

Characteristics	Symbol	Test Condition	V_{CC} (V)	Min	Max	Unit	
Positive threshold voltage	V_P	—	4.5	—	1.90	V	
			5.5	—	2.10		
Negative threshold voltage	V_N	—	4.5	0.50	—	V	
			5.5	0.60	—		
Hysteresis voltage	V_H	—	4.5	0.40	1.40	V	
			5.5	0.40	1.50		
High-level output voltage	V_{OH}	$V_{IN} = V_{IL}$	$I_{OH} = -50 \mu A$	4.5	4.4	—	V
			$I_{OH} = -8 \text{ mA}$	4.5	3.70	—	
Low-level output voltage	V_{OL}	$V_{IN} = V_{IH}$	$I_{OL} = 50 \mu A$	4.5	—	0.1	V
			$I_{OL} = 8 \text{ mA}$	4.5	—	0.55	
Input leakage current	I_{IN}	$V_{IN} = 5.5 \text{ V or GND}$	0 to 5.5	—	± 2.0	μA	
Quiescent supply current	I_{CC}	$V_{IN} = V_{CC} \text{ or GND}$	5.5	—	40.0	μA	
	I_{CCT}	Per input: $V_{IN} = 3.4 \text{ V}$ Other input: $V_{CC} \text{ or GND}$	5.5	—	1.50	mA	
Output leakage current (Power-OFF)	I_{OPD}	$V_{OUT} = 5.5 \text{ V}$	0	—	20.0	μA	

12.4. AC Characteristics (Unless otherwise specified, $T_a = 25\text{ }^\circ\text{C}$, Input: $t_r = t_f = 3\text{ ns}$)

Characteristics	Symbol	Note	V_{CC} (V)	C_L (pF)	Min	Typ.	Max	Unit
Propagation delay time	t_{PLH}, t_{PHL}		5.0 ± 0.5	15	—	5.0	7.6	ns
				50	—	6.5	9.6	
Input capacitance	C_{IN}		—		—	4	10	pF
Power dissipation capacitance	C_{PD}	(Note 1)	—		—	18	—	

Note 1: C_{PD} is defined as the value of the internal equivalent capacitance which is calculated from the operating current consumption without load. Average operating current can be obtained by the equation.

$$I_{CC(opr)} = C_{PD} \times V_{CC} \times f_{IN} + I_{CC}/6 \text{ (per gate)}$$

12.5. AC Characteristics (Unless otherwise specified, $T_a = -40\text{ to }85\text{ }^\circ\text{C}$, Input: $t_r = t_f = 3\text{ ns}$)

Characteristics	Symbol	V_{CC} (V)	C_L (pF)	Min	Max	Unit
Propagation delay time	t_{PLH}, t_{PHL}	5.0 ± 0.5	15	1.0	9.0	ns
			50	1.0	11.0	
Input capacitance	C_{IN}	—		—	10	pF

12.6. AC Characteristics (Unless otherwise specified, $T_a = -40\text{ to }125\text{ }^\circ\text{C}$, Input: $t_r = t_f = 3\text{ ns}$)

Characteristics	Symbol	V_{CC} (V)	C_L (pF)	Min	Max	Unit
Propagation delay time	t_{PLH}, t_{PHL}	5.0 ± 0.5	15	1.0	9.5	ns
			50	1.0	12.0	
Input capacitance	C_{IN}	—		—	10	pF

12.7. Noise Characteristics (Unless otherwise specified, $T_a = 25\text{ }^\circ\text{C}$, Input: $t_r = t_f = 3\text{ ns}$)

Characteristics	Symbol	Test Condition	V_{CC} (V)	Typ.	Limit	Unit
Quiet output maximum dynamic V_{OL}	V_{OLP}	$C_L = 50\text{ pF}$	5.0	0.5	0.8	V
Quiet output minimum dynamic V_{OL}	V_{OLV}	$C_L = 50\text{ pF}$	5.0	-0.5	-0.8	V
Minimum high-level dynamic input voltage	V_{IHD}	$C_L = 50\text{ pF}$	5.0	—	2.1	V
Maximum low-level dynamic input voltage	V_{ILD}	$C_L = 50\text{ pF}$	5.0	—	0.5	V

Package Dimensions

Unit: mm



Weight: 0.054 g (typ.)

Package Name(s)
Nickname: TSSOP14B

X-ON Electronics

Largest Supplier of Electrical and Electronic Components

Click to view similar products for [Inverters](#) category:

Click to view products by [Toshiba](#) manufacturer:

Other Similar products are found below :

[E5-652Z](#) [NLX2G04BMX1TCG](#) [CD4009UBE](#) [TC4584BFN](#) [NL17SG14AMUTCG](#) [NLU2GU04BMX1TCG](#) [NLV17SZ14DFT2G](#)
[NLV74HC04ADTR2G](#) [NLU1G04AMUTCG](#) [NLX2G04CMUTCG](#) [NLX2G04AMUTCG](#) [NLV27WZ04DFT1G](#) [NLU1G04CMUTCG](#)
[NL17SZU04P5T5G](#) [74LVC06ADTR2G](#) [74LVC04ADR2G](#) [NLV37WZ04USG](#) [NLX3G14FMUTCG](#) [NL17SZ04P5T5G](#) [NL17SG14P5T5G](#)
[NLV27WZU04DFT2G](#) [NLV17SG14DFT2G](#) [NLVHC1G04DFT2G](#) [MC14069UBD](#) [NLU3G14CMX1TCG](#) [NLX2G14BMX1TCG](#)
[NLX2GU04AMX1TCG](#) [74HCT04DT](#) [74HCT14DT](#) [74LCX14FT\(AJ\)](#) [EG8015](#) [GN14D](#) [74HC04DM/TR](#) [HG74HC04M/TR](#)
[CD40106DM/TR](#) [CD4007BE](#) [74HC14DN](#) [74HC14DM/TR](#) [CD4069UBE](#) [74HC125M/TR](#) [CD4069UBMT/TR](#) [HG74HC04MT/TR](#)
[74HC14DMT/TR](#) [HT74HC04ARZ](#) [74HC14-HXY](#) [IW4069UBN](#) [RS1GT04XC5](#) [RS2G17XC6](#) [RS2G14XC6](#) [RS2G04XC6](#)