

TOSHIBA BiCD Integrated Circuit

Silicon Monolithic

TB62208FNG

BiCD Constant-Current Two-Phase Bipolar Stepping Motor Driver IC

The TB62208FNG is a two-phase bipolar stepping motor driver using a PWM chopper.

Fabricated with the BiCD process, the TB62208FNG is rated at 40 V/1.8 A.

The on-chip voltage regulator allows control of a stepping motor with a single VM power supply.

Features

- Bipolar stepping motor driver
- PWM constant-current drive
- Provides phase inputs to allow 2-phase and 1-2-phase excitation.
- BiCD process: Uses DMOS FETs as output power transistors.
- High voltage and current: 40 V/1.8 A
- Thermal shutdown (TSD), over-current shutdown (ISD), and power-on-resets (PORs) for VMR and VCCR

Package: HTSSOP48-P-300-0.50 (with thermal pad at bottom)

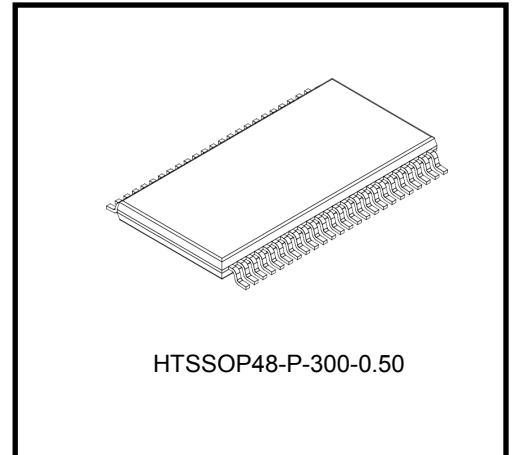

Weight: 0.21g (typ.)

Block Diagram

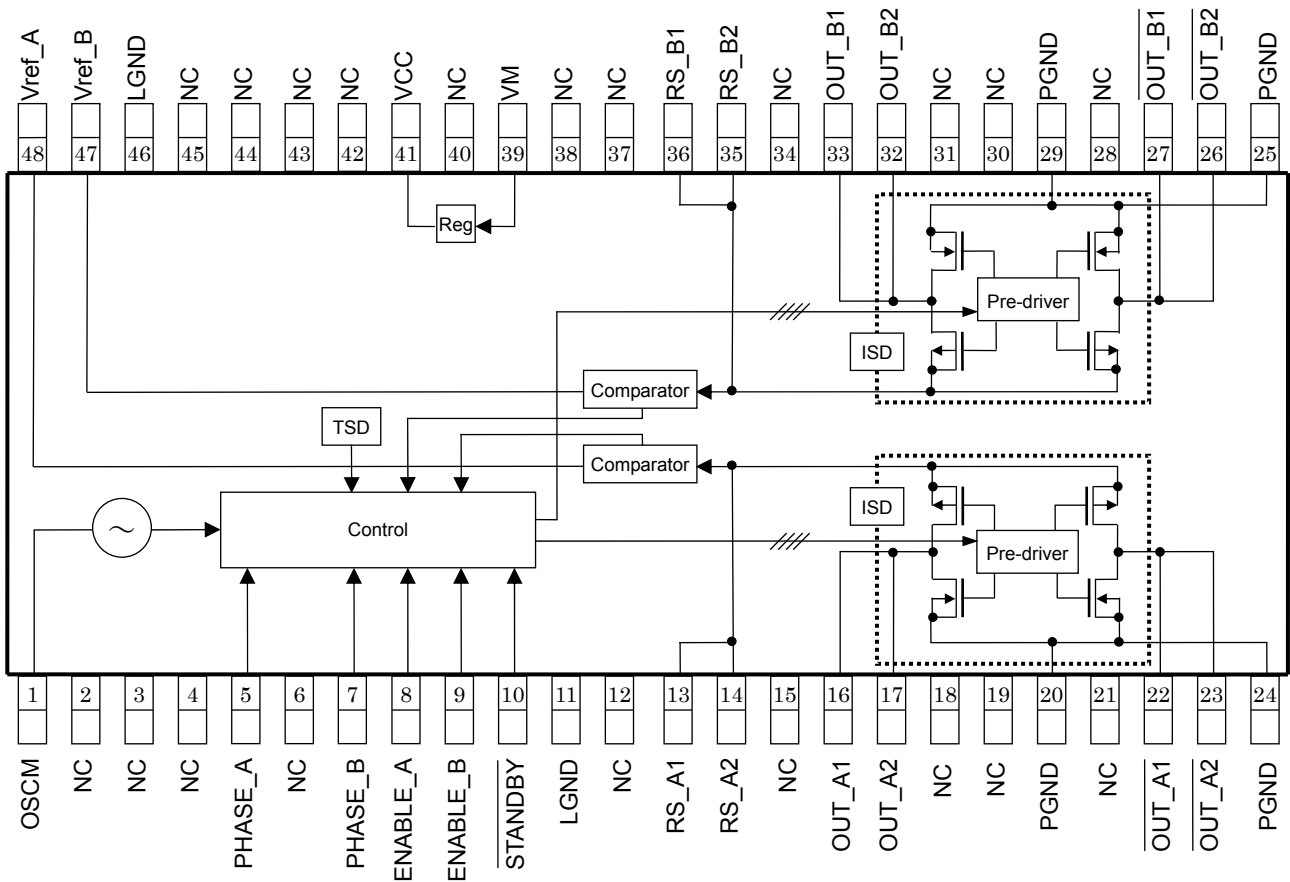

In the block diagram, part of the functional blocks or constants may be omitted or simplified for explanatory purposes.

Pin Function

Pin #	Pin Name	Function	Pin #	Pin Name	Function
1	OSCM	Oscillator pin for PWM choppers	25	PGND	Power GND
2	NC	No-connect	26	OUT_B2	Phase-B negative driver output 1
3	NC	No-connect	27	OUT_B1	Phase-B negative driver output 2
4	NC	No-connect	28	NC	No-connect
5	PHASE_A	Phase-A PWM current direction select	29	PGND	power GND
6	NC	No-connect	30	NC	No-connect
7	PHASE_B	Phase-B PWM current direction select	31	NC	No-connect
8	ENABLE_A	Phase-A enable SW ON:5V OFF: GND	32	OUT_B2	Phase-B positive driver output 2
9	ENABLE_B	Phase-B enable SW ON:5V OFF: GND	33	OUT_B1	Phase-B positive driver output 1
10	STANDBY	Power-saving waiting mode with OSCM stopping and output disabling	34	NC	No-connect
11	LGND	GND for low-voltage parts, such as logic	35	Rs_B2	Power supply for the Phase-B motor coil; sensing of the sink current
12	NC	No-connect	36	Rs_B1	
13	Rs_A1	Power supply for the Phase-A motor coil; sensing of the sink current	37	NC	No-connect
14	Rs_A2	Power supply for the Phase-A motor coil; sensing of the sink current	38	NC	No-connect
15	NC	No-connect	39	VM	VM reference monitor
16	OUT_A1	Phase-A positive driver output	40	NC	No-connect
17	OUT_A2	Phase-A positive driver output	41	Vcc	Smoothing filter for built-in 5V power supply for logic
18	NC	No-connect	42	NC	No-connect
19	NC	No-connect	43	NC	No-connect
20	PGND	Power GND	44	NC	No-connect
21	NC	No-connect	45	NC	No-connect
22	OUT_A1	Phase-A negative driver output	46	LGND	GND for low-voltage parts, such as logic
23	OUT_A2	Phase-A negative driver output	47	Vref_B	Tunes the current level for phase-B motor drive by supplied bias
24	PGND	Power GND	48	Vref_A	Tunes the current level for phase-A motor drive by supplied bias

Pin Interfaces

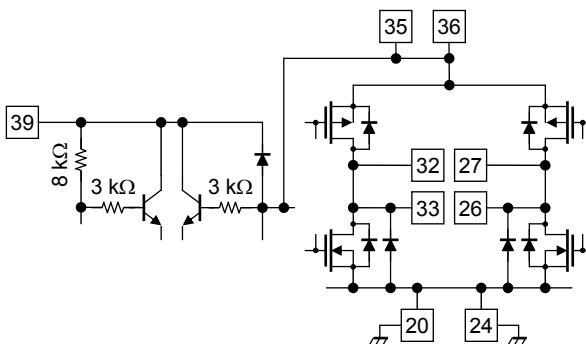
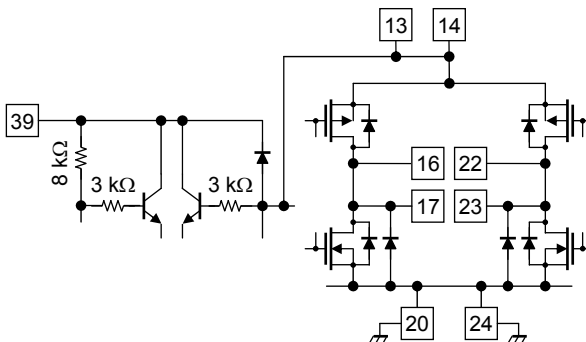
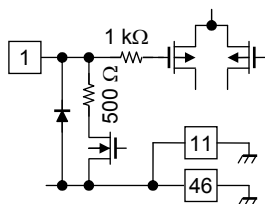
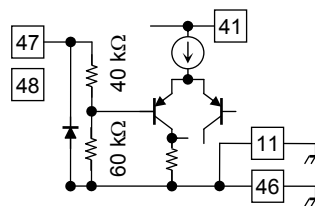
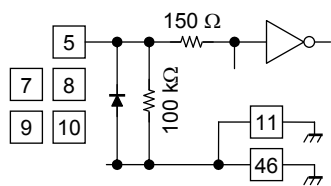

The equivalent circuit diagrams may be simplified or some parts of them may be omitted for explanatory purposes.

Output Function Table

	Pin name			OUT(+)	OUT(-)	OSC_M
	STAND BY	PHASE	Pin Name			
Function	Power-saving waiting SW "L" : disable the OSCM and Outputs.The motor can not be operated	The determination pin of the direction of motor current "H" : Current flows into OUT(-) from OUT(+)	The ON/FFF switch of the output transistors "L" :Output pins will be in a high impedance state.			
State	L	X	X	OFF	OFF	a halt
	H	X	L	OFF	OFF	oscillation
	H	H	H	H	L	oscillation
	H	L	H	L	H	oscillation

X : Don't-care

Protection Features

- (1) Thermal shutdown (TSD)
The thermal shutdown circuit turns off all the outputs when the junction temperature (T_j) exceeds 150°C (typical).
The outputs retain the current states.
The TB62208FNG exits TSD mode and resumes normal operation when the TB62208FNG is rebooted or the $\overline{\text{STANDBY}}$ pin is changed from High to Low and then to High.
- (2) Power-on-resets (PORs) for VMR and VCCR (V_M and V_{CC} voltage monitor)
The outputs are forced off until V_M and V_{CC} reach the rated voltages.
- (3) Overcurrent shutdown (ISD)
Each phase has an overcurrent shutdown circuit, which turns off the corresponding outputs when the output current exceeds the shutdown trip threshold (above the maximum current rating: 2.0 A minimum).
The TB62208FNG exits ISD mode and resumes normal operation when the $\overline{\text{STANDBY}}$ pin is changed from High to Low and then to High.
This circuit provides protection against short-circuit by temporarily disabling the device. Important notes on this feature will be provided later.

Absolute Maximum Ratings (Ta = 25°C)

Characteristics	Symbol	Rating	Unit
Motor power supply	V _M	40	V
Motor output voltage	V _{out}	40	V
Output current (Note 1)	I _{OUT}	1.8	A
Logic input voltage	V _{IN}	-0.5~6.0	V
Power dissipation (Stand-alone)	P _D	1.3	W
Operating temperature	T _{opr}	-20 to 85	°C
Storage temperature	T _{stg}	-55 to 150	°C
Junction temperature	T _{j(max)}	150	°C

Note 1: As a guide, the maximum output current should be kept below 1.0 A per phase. The maximum output current may be further limited by thermal considerations, depending on ambient temperature and board conditions.

T_a: Ambient temperature

T_{opr}: Ambient temperature while the TB62208FNG is active

T_j: Junction temperature while the TB62208FNG is active. The maximum junction temperature is limited by the thermal shutdown (TSD) circuitry. Please design to keep the maximum current below a certain level so that the maximum junction temperature, T_{j(max)}, will not exceed 120°C.

Cautions on absolute maximum ratings:

The absolute maximum ratings of a semiconductor device are a set of ratings that must not be exceeded, even for a moment. Do not exceed any of these ratings.

Exceeding the rating(s) may cause the device breakdown, damage or deterioration, and may result injury by explosion or combustion.

The value of even one parameter of the absolute maximum ratings should not be exceeded under any circumstances. The TB62208FNG does not have overvoltage protection. Therefore, the device is damaged if a voltage exceeding its rated maximum is applied.

All voltage ratings including supply voltages must always be followed. The section on the protection features on the latter page should also be referred to.

Operating Ranges (Ta = 0 to 85°C)

Characteristics	Symbol	Test Condition	Min	Typ.	Max	Unit
Supply voltage for internal circuitry	V _{CC}	Internally generated	4.5	5.0	5.5	V
Motor supply voltage	V _M	—	10	24	38	V
Output current	I _{OUT}	Ta = 25°C; Per phase	—	1.2	1.8	A
Logic input voltage	V _{IN(H)}	Logic High level	2.0	3.3	5	V
	V _{IN(L)}	Logic Low level	GND	—	1.0	V
Phase input frequency	f _{PHASE}	—	—	1.0	150	kHz
Chopper frequency	f _{chop}	—	80	100	120	kHz
V _{ref} reference voltage	V _{ref}	—	GND	3.0	3.6	V
Voltage across the current-sensing resistor pins (Voltage across VM and RS)	V _{RS}	Referenced to the VM pin (Note)	0	±1.0	±1.5	V

Note: The maximum VRS voltage should not exceed the maximum rated voltage.

Electrical Characteristics (Ta = 25°C, VM = 24 V, unless otherwise specified)

Characteristics		Symbol	Test Circuit	Test Condition	Min	Typ.	Max	Unit
Input hysteresis voltage		V _{IN (HIS)}	DC	Logic input pins (Note)	100	200	300	mV
Logic input current	High	I _{IN (H)}	DC	Logic input pins; V _{IN} = 5 V	35	50	75	μA
	Low	I _{IN (L)}		Logic input pins; V _{IN} = 0 V	—	—	1.0	
Supply current (V _M pin)		I _{M1}	DC	Outputs open Logic inputs: All Lows Logic and outputs disabled	—	2	3	mA
		I _{M2}		Outputs open; f _{PHASE} = 1 kHz Logic enabled; all outputs disabled	—	3.5	5	
		I _{M3}		Outputs open; f _{PHASE} = 4 kHz Logic enabled (2-phase excitation; 100-kHz chopping)	—	5	7	
Output leakage current	High-side	I _{OH}	DC	V _{RS} = V _M = 40 V; V _{OUT} = 0 V; Logic inputs: All Lows	—	—	1	μA
	Low-side	I _{OL}	DC	V _{RS} = V _M = V _{OUT} = 40 V; Logic inputs: all Lows	1	—	—	μA
Channel-to-channel current differential		ΔI _{OUT1}	DC	Channel-to-channel error	−5	0	5	%
Output current error relative to the predetermined value		ΔI _{OUT2}	DC	I _{OUT} = 1000 mA	−5	0	5	%
RS pin current		I _{RS}	DC	V _{RS} = V _M = 24 V STANDBY = L	0	—	10	μA
Drain-source ON-resistance of the output transistors (upper and lower sum)		R _{ON (D-S)}	DC	I _{OUT} = 1.0 A, T _j = 25°C	—	1.0	1.5	Ω

Note : V_{IN(L→H)} is defined as the V_{IN} voltage that causes the outputs (pins 10 and 11) to change when a pin under test is gradually raised from 0 V. V_{IN(H→L)} is defined as the V_{IN} voltage that causes the outputs (pins 10) to change when the pin is then gradually lowered.
The difference between V_{IN(L→H)} and V_{IN(H→L)} is defined as the input hysteresis.

Electrical Characteristics (Ta = 25°C, VM = 24 V, unless otherwise specified)

Characteristics	Symbol	Test Circuit	Test Condition	Min	Typ.	Max	Unit
Vref input voltage range	Vref	DC	VM = 24 V, $\overline{\text{STANDBY}} = \text{H}$, outputs enabled, PHASE = 1 kHz	GND	3.0	5.0	V
Vref input current	Iref	DC	$\overline{\text{STANDBY}} = \text{H}$ output enabled, Vref = 3.0 V	20	35	50	μA
Vref decay rate	Vref (GAIN)	DC	$\overline{\text{STANDBY}} = \text{H}$, output enabled, Vref = 2.0 V	1/4.8	1/5.0	1/5.2	-
TSD threshold (Note 1)	TjTSD	DC	VM = 24 V	140	155	170	°C
VM recovery voltage	VMR	DC	$\overline{\text{STANDBY}} = \text{H}$	7.0	8.0	9.0	V
Overcurrent trip threshold (Note 2)	ISD	—	—	2.0	3.0	4.0	A

Note 1: Thermal shutdown (TSD) circuitry

When the junction temperature of the device has reached the threshold, the TSD circuitry is tripped, causing the internal reset circuitry to turn off the output transistors.

The TSD circuitry is tripped at a temperature between 140°C (min) and 160°C (max). Once tripped, the TSD circuitry keeps the output transistors off until $\overline{\text{STANDBY}}$ is deasserted High.

Note 2: Overcurrent shutdown (ISD) circuitry

When the output current has reached the threshold, the ISD circuitry is tripped, causing the internal reset circuitry to turn off the output transistors.

To prevent the ISD circuitry from being tripped due to switching noise, it has a masking time of four CR oscillator cycles. Once tripped, it takes a maximum of four cycles to exit ISD mode and resume normal operation.

The ISD circuitry remains active until the $\overline{\text{STANDBY}}$ pin is changed from Low to High again.

The TB62208FNG remains in Standby mode while in ISD mode.

Back-EMF

- While a motor is rotating, there is a timing at which power is fed back to the power supply. At that timing, the motor current recirculates back to the power supply due to the effect of the motor back-EMF.
If the power supply does not have enough sink capability, the power supply and output pins of the device might rise above the rated voltages. The magnitude of the motor back-EMF varies with usage conditions and motor characteristics. It must be fully verified that there is no risk that the TB62208FNG or other components will be damaged or fail due to the motor back-EMF.

Cautions on Overcurrent Shutdown (ISD) and Thermal Shutdown (TSD)

- The ISD and TSD circuits are only intended to provide temporary protection against irregular conditions such as an output short-circuit.
- If the device is used beyond the specified operating ranges, these circuits may not operate properly; then the device may be damaged due to an output short-circuit.
- The ISD circuit is only intended to provide a temporary protection against an output short-circuit. If such a condition persists for a long time, the device may be damaged due to overstress. Overcurrent conditions must be removed immediately by external hardware.

IC Mounting

Do not insert devices in the wrong orientation or incorrectly. Otherwise, it may cause the device breakdown, damage and/or deterioration.

AC Electrical Characteristics (Ta = 25°C, VM = 24 V, 6.8 mH/5.7Ω)

Characteristics	Symbol	Test Circuit	Test Condition	Min	Typ.	Max	Unit
Phase frequency	f _{PHASE}	AC	OSCM = 1600 kHz	–	–	400	kHz
Minimum phase pulse width	t _{PHASE}	AC	—	100	–	–	ns
	t _{wp}	AC		50	–	–	ns
	t _{wn}	AC		50	–	–	ns
Output transistor switching characteristics	t _r	—	—	150	200	250	ns
	t _f	—		100	150	200	ns
	t _{pLH(P)MAX}	—	PHASE to OUT	500	850	1200	ns
	t _{pHL(P)MAX}	—		500	850	1200	ns
	t _{pLH(P)MIN}	—		250	600	950	ns
	t _{pHL(P)MIN}	—		250	600	950	ns
	t _{pLH(O)}	—	CR(OSC) to OUT	300	600	900	ns
	t _{pHL(O)}	—		350	650	950	ns
Blanking time for current spike prevention	t _{BLANK}	—	I _{OUT} = 1.0 A	200	300	500	ns
CR oscillation reference frequency	f _{CR}	—	C _{OSC} = 270 pF, R _{OSC} = 3.6 kΩ	1200	1600	2000	kHz
Chopper frequency range	f _{chop(RANGE)}	—	V _M = 24 V, outputs enabled, (I _{OUT} = 1.0 A)	40	100	150	kHz
Predefined chopper frequency	f _{chop}	—	Outputs enabled (I _{OUT} = 1.0 A), OSCM = 1600 kHz	–	100	–	kHz
ISD masking time	t _{ISD(Mask)}	AC	The number of OSCM pulse. Until it detects over-current after output current exceeds an ISD threshold value by short-circuit to VM or GND to output.	–	4	–	–
ISD on-time	t _{ISD}	AC		4	–	8	–

OSC_M frequency can be calculated by the following approximate formula. Please give as a reference of frequency adjustment.

$$f_{OSCM} = \frac{1}{0.6 \times C \times (R_1 + 500)}$$

.....C, R₁: The external constant for OSCM
(C=270pF、R₁=3.6kΩ on an application circuit diagram)

Current Waveform in Mixed Decay Mode

For constant-current control, Mixed-Decay mode starts out in Fast-Decay mode for 37.5% of the whole period and then is followed by Slow-Decay mode for the remainder of the period.

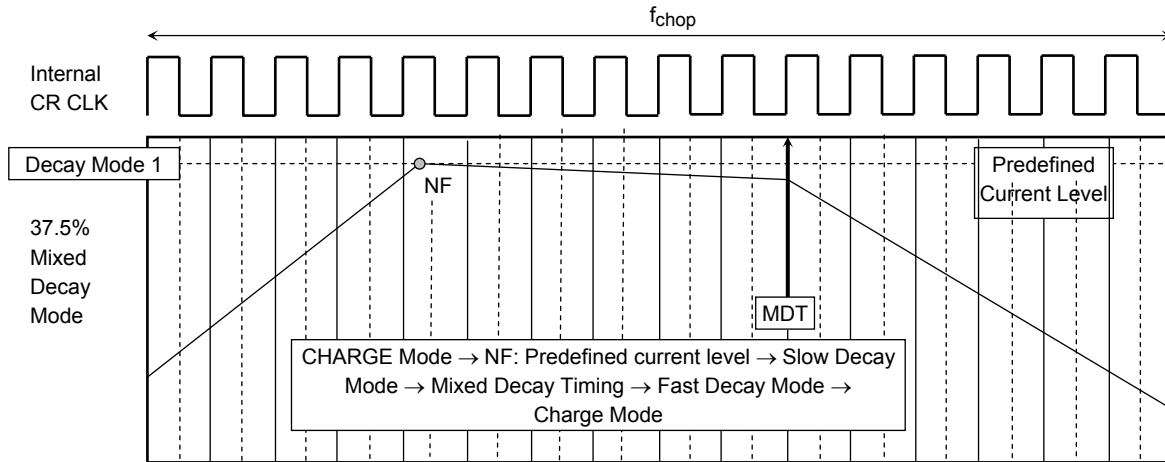

Current Waveform in MIXED DECAY Mode

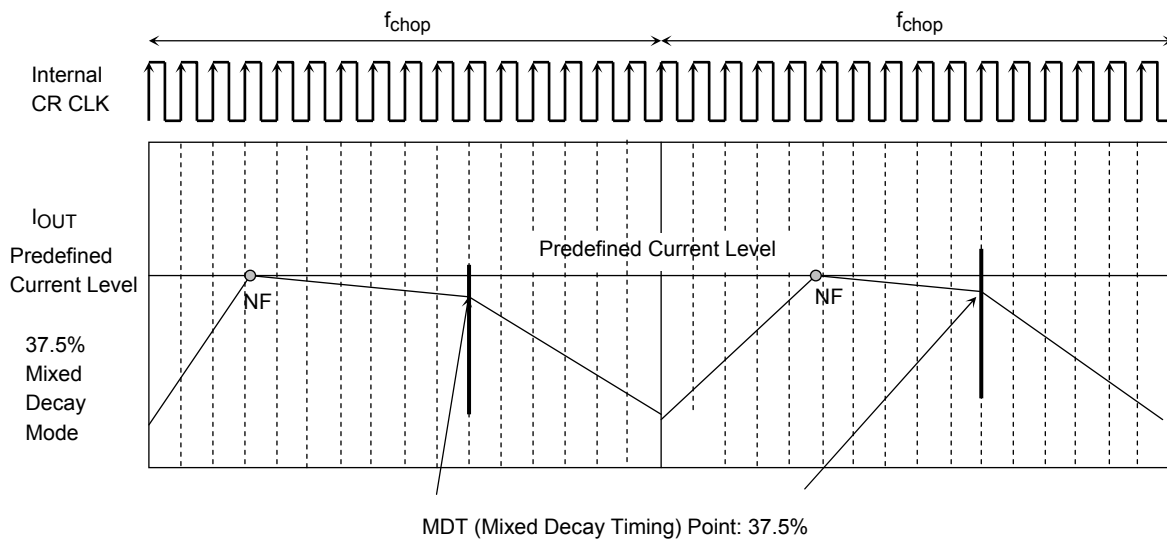

Timing charts may be simplified for explanatory purposes.

• Waveforms of Internal CR CLK and Output Signals (2-Phase Excitation Mode)

Timing charts may be simplified for explanatory purposes.

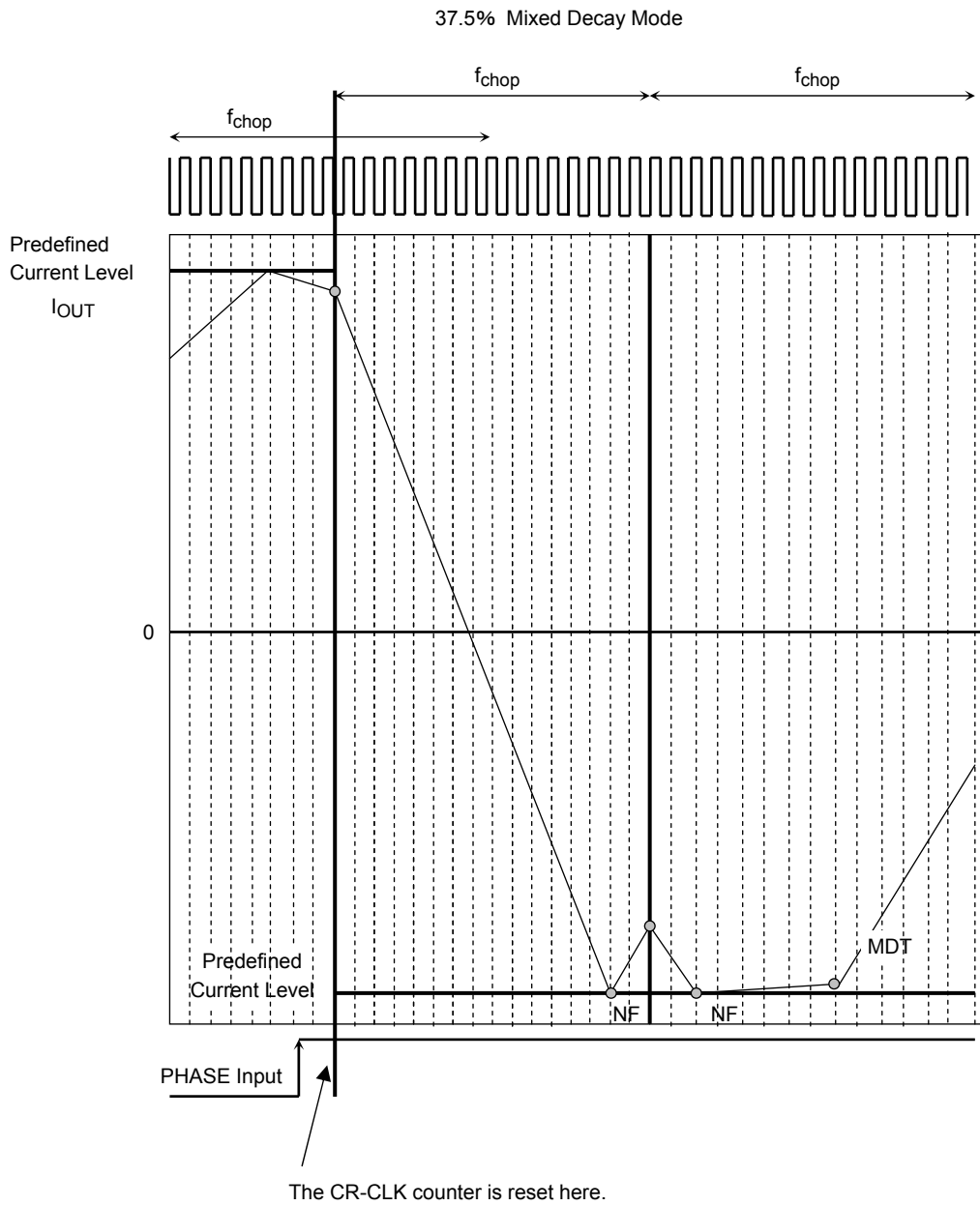

• Output Transistor Operating Modes

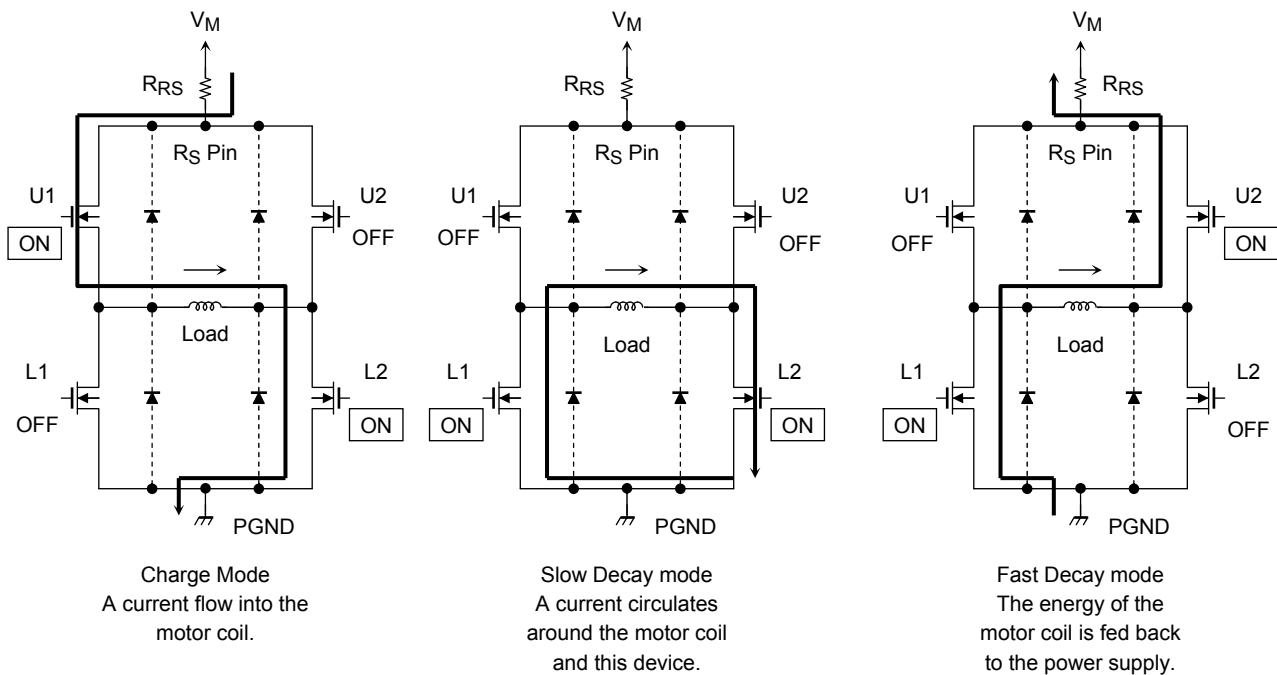

Output Transistor Operating Modes

CLK	U1	U2	L1	L2
Charge	ON	OFF	OFF	ON
Slow	OFF	OFF	ON	ON
Fast	OFF	ON	ON	OFF

Note: This table shows an example of when the current flows as indicated by the arrows in the above figures. If the current flows in the opposite direction, refer to the following table.

CLK	U1	U2	L1	L2
Charge	OFF	ON	ON	OFF
Slow	OFF	OFF	ON	ON
Fast	ON	OFF	OFF	ON

The TB62208FNG switches among Charge, Slow Decay and Fast Decay modes automatically for constant-current control. The equivalent circuit diagrams are simplified or some parts of them may be omitted for explanatory purposes.

Calculation of the Predefined Output Current

For PWM constant-current control, the TB62208FNG uses a clock generated by the CR oscillator. The peak output current can be set via the current-sensing resistor (R_{RS}) and the reference voltage (V_{ref}), as follows:

$$I_{out} = V_{ref} / 5 / R_{RS} (\Omega)$$

where, $1/5$ is the V_{ref} decay rate, $V_{ref(GAIN)}$. For the value of $V_{ref(GAIN)}$, see the Electrical Characteristics table.

For example, when $V_{ref} = 3 V$, to generate an output current (I_{OUT}) of 0.8 A, $R_{RS} = 0.75\Omega$. ($\geq 0.5 W$)

IC Power Consumption

The power consumed by the TB62208FNG is approximately the sum of the following two: 1) the power consumed by the output transistors, and 2) the power consumed by the logic and pre-drivers.

- The power consumed by the output transistors is calculated, using the $R_{ON(D-S)}$ value of 1.5 Ω .

Whether in Charge, Fast Decay or Slow Decay mode, two of the four transistors comprising each H-bridge contribute to its power consumption at a given time.

Thus the power consumed by each H-bridge is given by:

$$P \text{ (out)} = I_{OUT} \text{ (A)} \times V_{DS} \text{ (V)} = 2 \times I_{OUT}^2 \times R_{ON} \dots\dots\dots(1)$$

In two-phase excitation mode (in which two phases have a phase difference of 90°), the average power consumption in the output transistors is calculated as follows:

$R_{ON} = 1.50 \Omega$ (@ 1.0 A)
 I_{OUT} (Peak: max) = 1.0 A
 $V_M = 24 \text{ V}$

$$P \text{ (out)} = 2 \times 1.0^2 \text{ (A)} \times 1.50 \text{ (\Omega)} = 3.0 \text{ (W)} \dots\dots\dots(2)$$

- The power consumption in the IM domain is calculated separately for normal operation and standby modes:

$I_{IM3} = 5.0 \text{ mA}$ (typ.): Normal operation mode
 $I_{IM1} = 2.0 \text{ mA}$ (typ.): Standby mode

The current consumed in the logic portion of the TB62208FNG is indicated as IMx. The logic operates off a voltage regulator that is internally connected to the VM power supply. It consists of the logic connected to VM (24 V) and the network affected by the switching of the output transistors. The total power consumed by IMx can be estimated as:

$$P \text{ (IM)} = 24 \text{ (V)} \times 0.005 \text{ (A)} = 0.12 \text{ (W)} \dots\dots\dots(3)$$

Hence, the total power consumption of the TB62208FNG is:

$$P = P \text{ (out)} + P \text{ (IM)} = 3.16 \text{ (W)}$$

The standby power consumption is given by:

$$P \text{ (Standby)} + P \text{ (out)} = 24 \text{ (V)} \times 0.002 \text{ (A)} = 0.048 \text{ (W)}$$

Board design should be fully verified, taking thermal dissipation into consideration.

• Test Points for AC Specifications

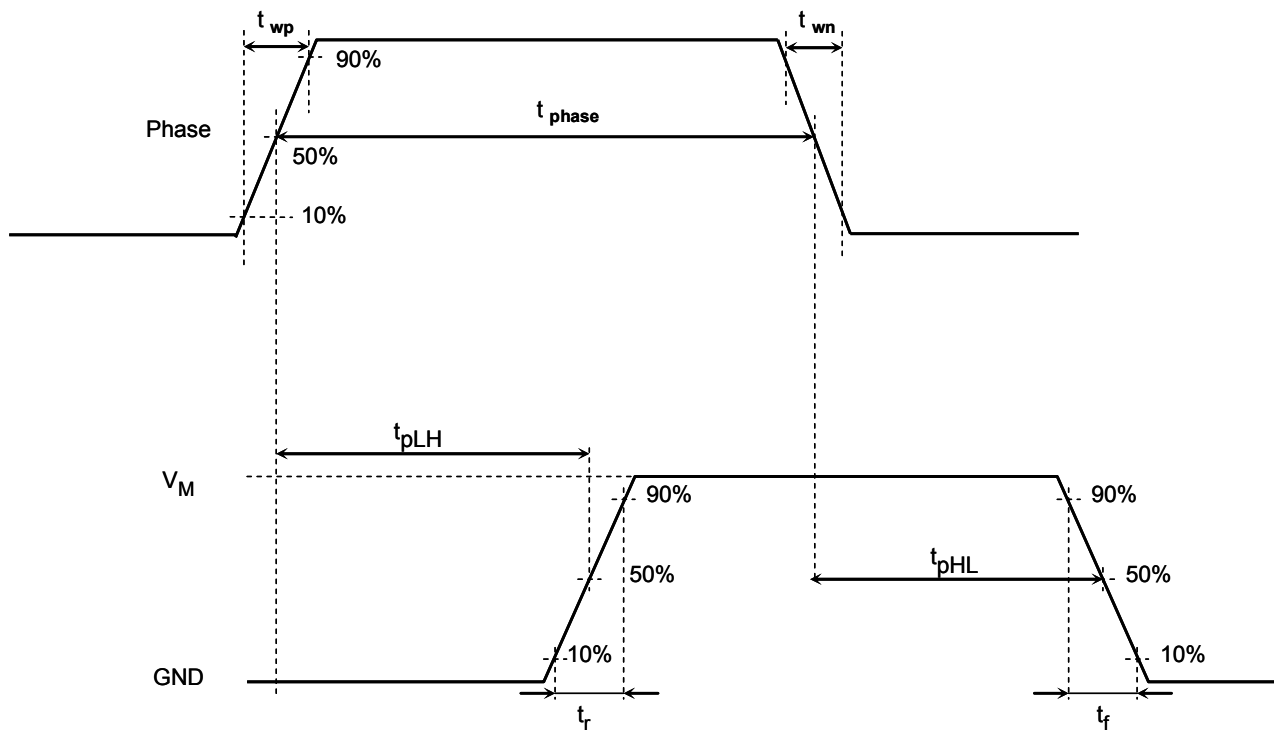
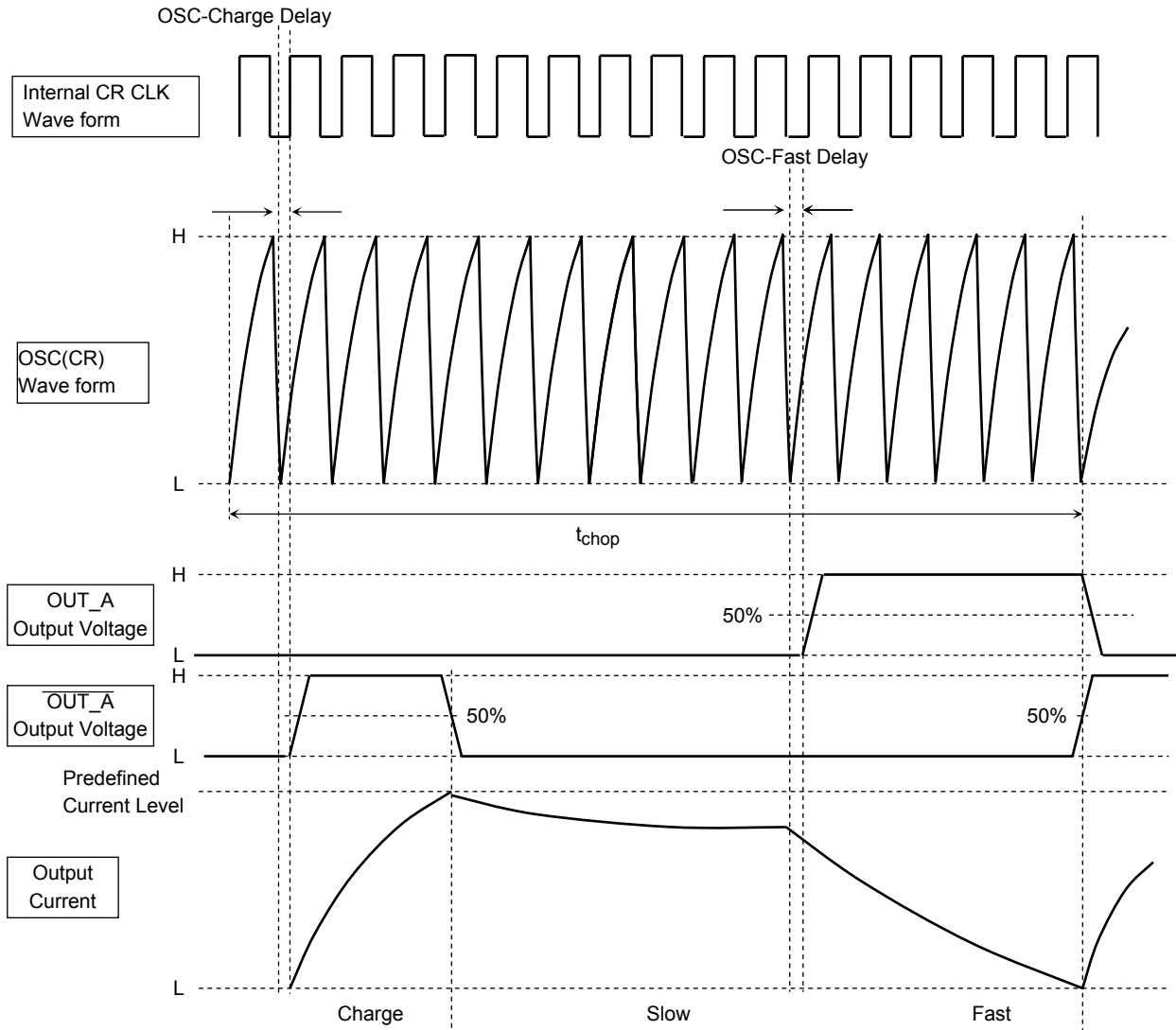

Figure 1 Timing Waveforms and Symbols

Timing charts may be simplified for explanatory purposes.

• OSC-Charge Delay

The internal CR CLK signal is derived from the rising slope of the oscillator signal, as shown below. The internal CRL CLK signal has a delay of approximately 1 μ s maximum, relative to the CR waveform, when the CR frequency = 1600 kHz.



Timing charts may be simplified for explanatory purposes.

Phase Sequences

Two-Phase Excitation Mode

In two-phase excitation mode, the ENABLE input is held at logic High (except when the motor is off).

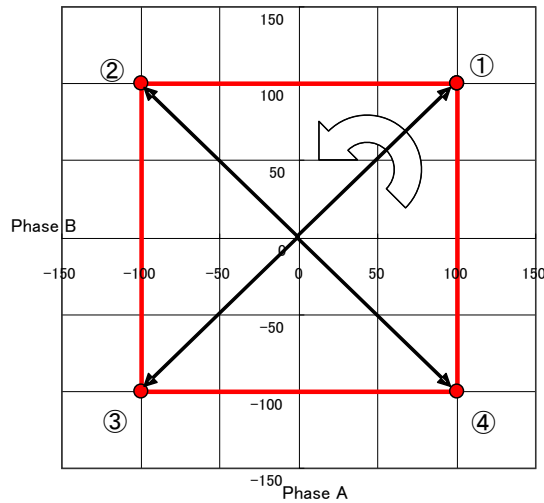
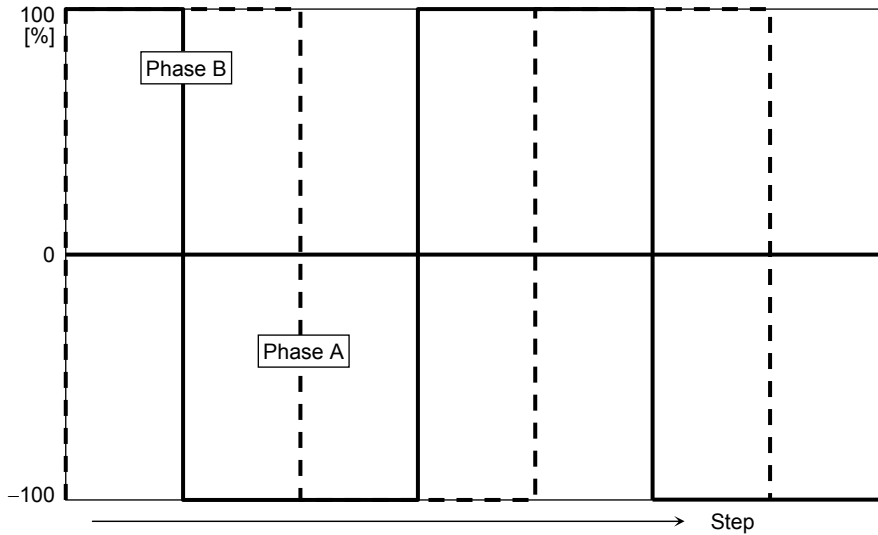
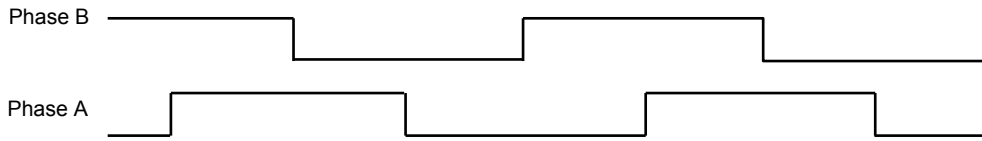

Note: The two-phase excitation mode is susceptible to significant load variations incurred by the motor back-EMF. In Slow Decay mode, a current swell caused by the motor back-EMF might not be cut down.

1-2-Phase Excitation Mode

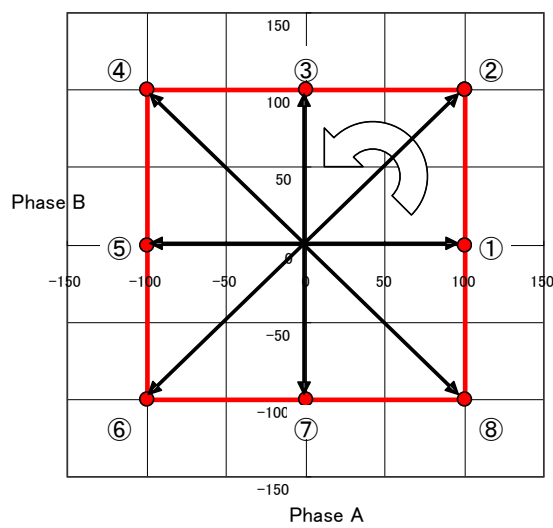
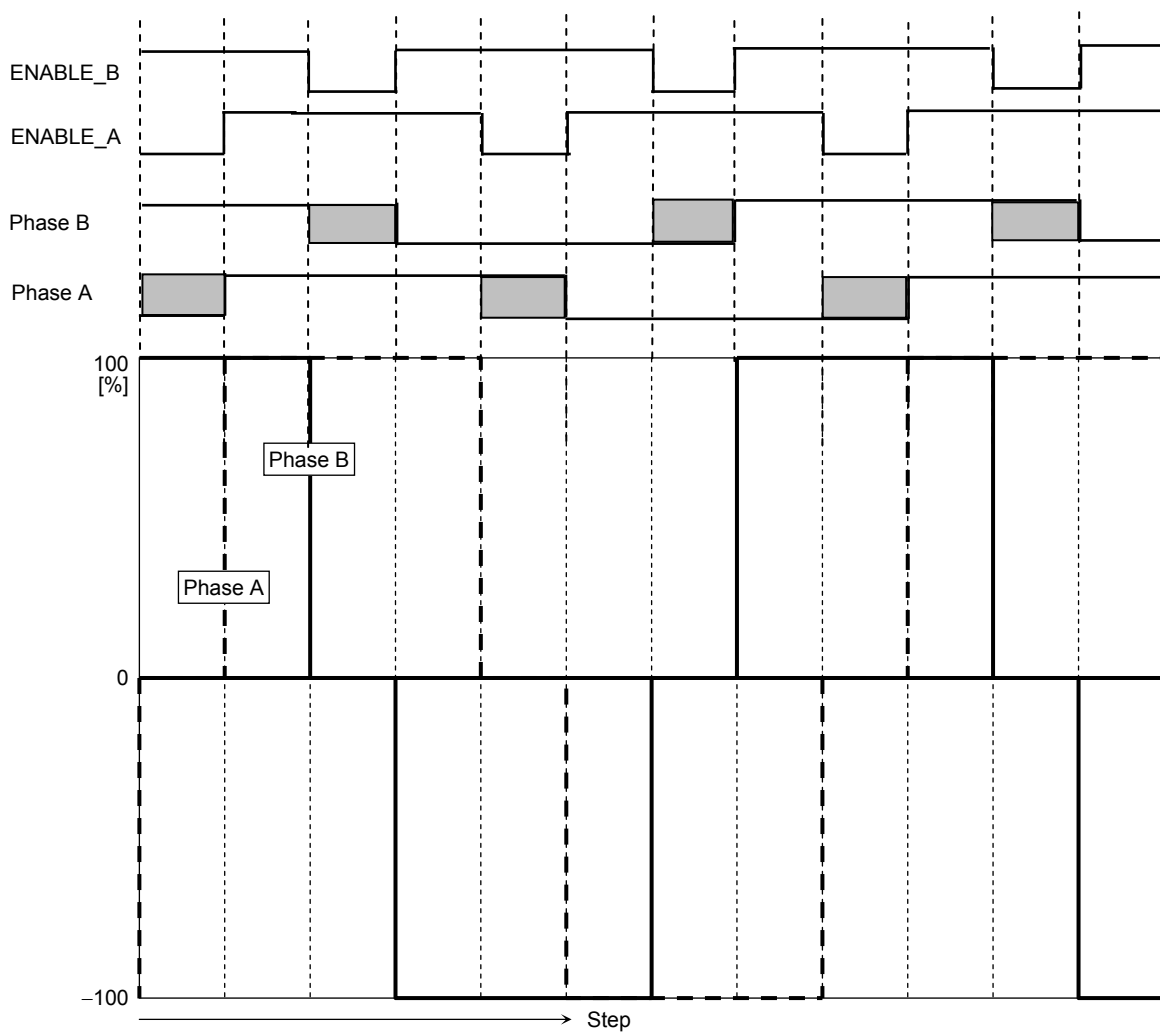

Example of a 1-2-Phase Excitation Sequence, Including Reverse Rotation

Overcurrent Shutdown (ISD) Circuitry

ISD Masking Time and ISD On-Time

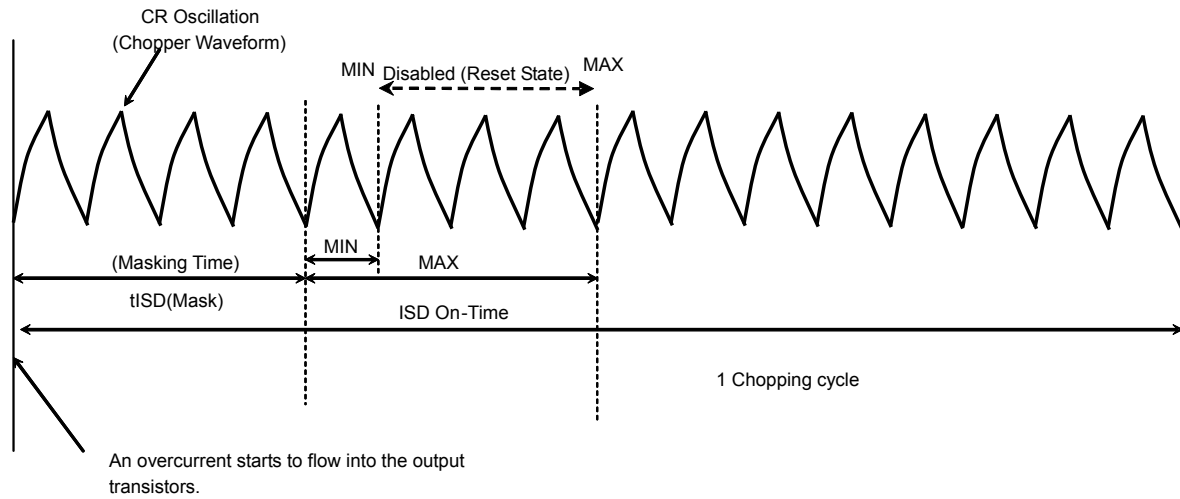

The overcurrent shutdown (ISD) circuitry has a masking time to prevent current spikes during I_{rr} and switching from erroneously tripping the ISD circuitry. The masking time is a function of the chopper frequency obtained by CR:

$$\text{Masking time} = 4 \times \text{OSCM period}$$

The minimum and maximum times taken to turn off the output transistors since an overcurrent flows into them are:

$$\text{Min: } 4 \times \text{OSCM period}$$

$$\text{Max: } 8 \times \text{OSCM period}$$

It should be noted that these values assume a case in which an overcurrent condition is detected in an ideal manner. The ISD circuitry might not work, depending on the control timing of the output transistors.

Therefore, a protection fuse must always be added to the V_M power supply as a safety precaution. The optimal fuse capacitance varies with usage conditions, and one that does not adversely affect the motor operation or exceed the power dissipation rating of the TB62208FNG should be selected.

$P_D - T_a$ (Package Power Dissipation)

When mounted on a specialized board (140 mm × 70 mm × 1.6 mm: 38°C/W: typ.)

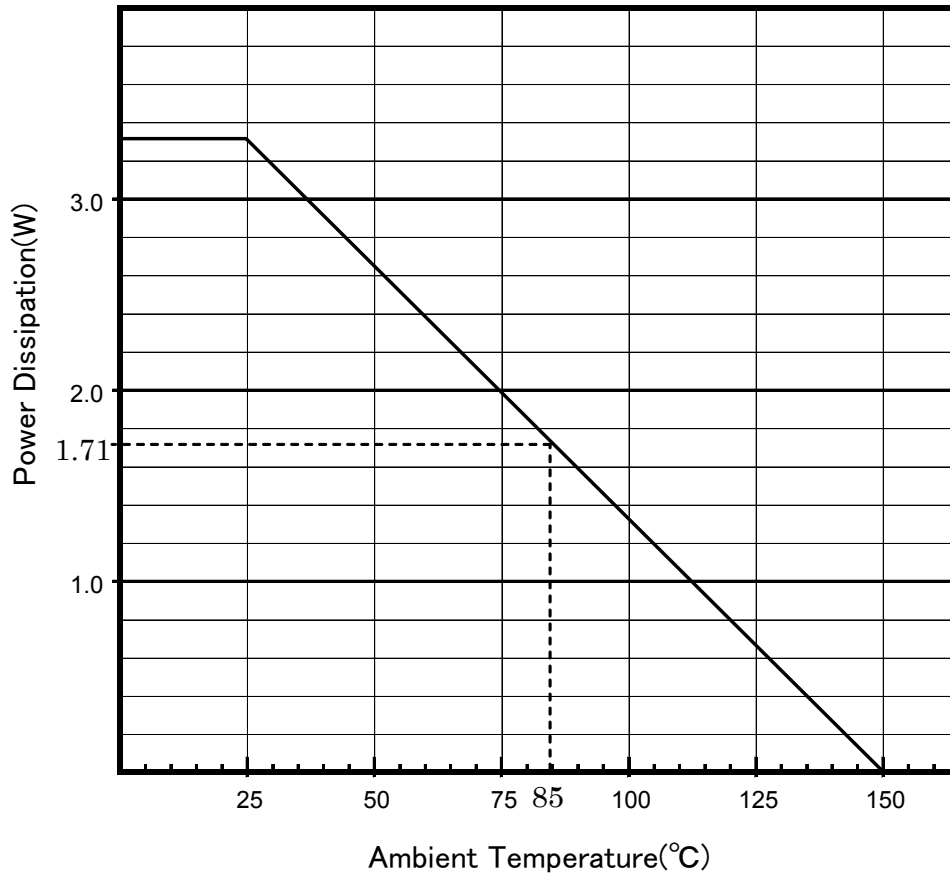

Application Circuit

The values shown in the following figure are typical values. For input conditions, see the “Operating Conditions” tables.

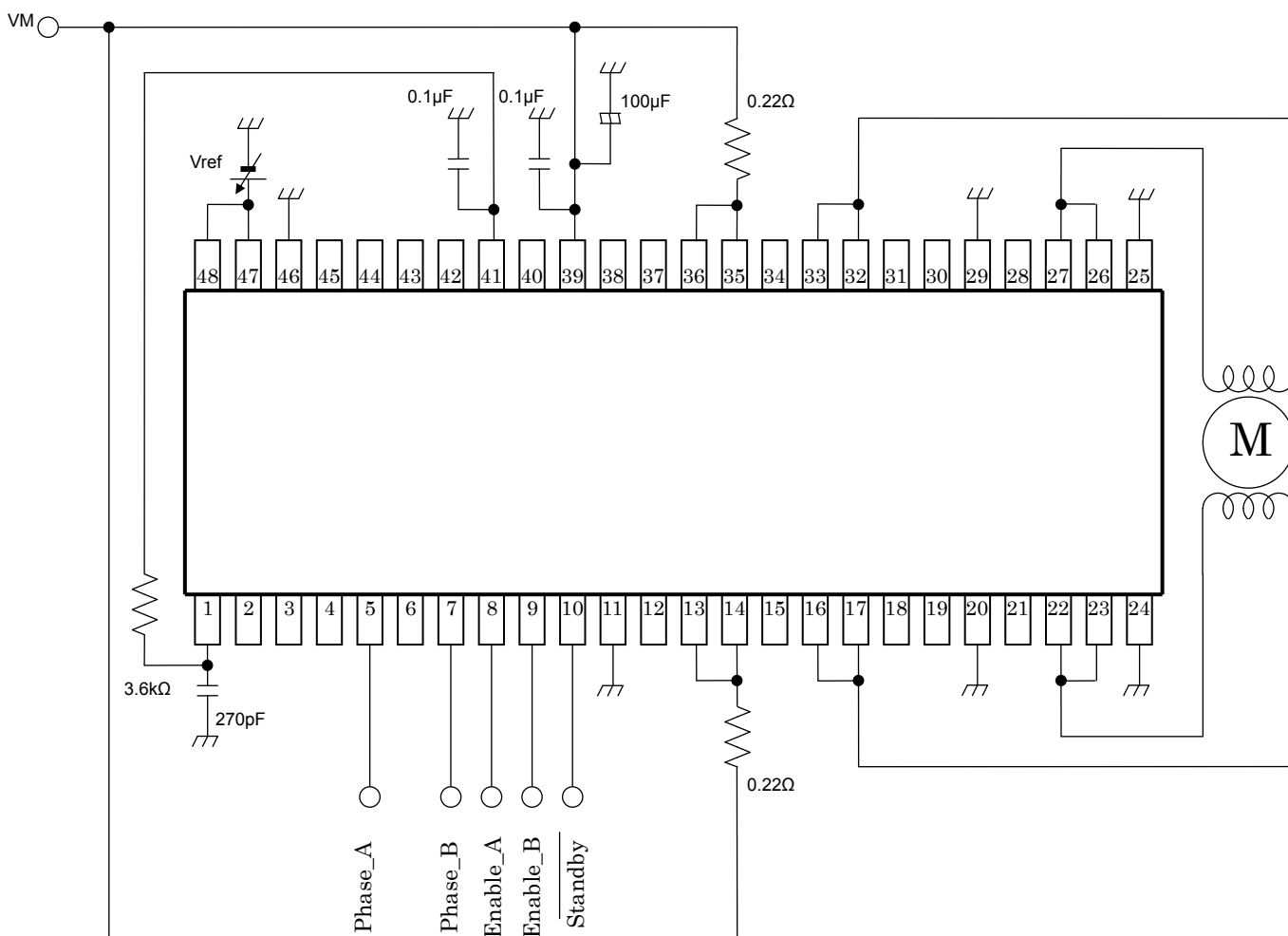

Note: Bypass capacitors should be added as necessary.

It is recommended to use a single ground plane for the entire board whenever possible, and an efficient grounding method should be considered for heat dissipation.

In cases where mode setting pins are controlled via switches, either pull-down or pull-up resistors should be added to them to avoid floating states.

For a description of the input values, see the “Output Function Table.”

The above application circuit example is presented only as a guide and should be fully evaluated prior to production. Also, no intellectual property right is ceded in any way whatsoever in regard to its use.

The external components in the above diagram are used to test the electrical characteristics of the device; it is not guaranteed that no system malfunction or failure will not occur.

Careful attention should be paid to the layout of the output, V_{DD} (V_M) and GND traces to avoid short-circuits across output pins or to the power supply or ground. If such a short-circuit occurs, the TB62208FNG may be permanently damaged. Also, if the device is installed in a wrong orientation, a high voltage might be applied to components with lower voltage ratings, causing them to be damaged. The TB62208FNG does not have an overvoltage protection circuit. Thus, if a voltage exceeding the rated maximum voltage is applied, the TB62208FNG will be damaged; it should be ensured that it is used within the specified operating conditions.

Notes on Contents

1. Block Diagrams

Some of the functional blocks, circuits, or constants in the block diagram may be omitted or simplified for explanatory purposes.

2. Equivalent Circuits

The equivalent circuit diagrams may be simplified or some parts of them may be omitted for explanatory purposes.

3. Timing Charts

Timing charts may be simplified for explanatory purposes.

4. Application Circuits

The application circuits shown in this document are provided for reference purposes only. Thorough evaluation is required, especially at the mass production design stage.

Toshiba does not grant any license to any industrial property rights by providing these examples of application circuits.

5. Test Circuits

Components in the test circuits are used only to obtain and confirm the device characteristics. These components and circuits are not guaranteed to prevent malfunction or failure from occurring in the application equipment.

IC Usage Considerations

Notes on handling of ICs

- (1) The absolute maximum ratings of a semiconductor device are a set of ratings that must not be exceeded, even for a moment. Do not exceed any of these ratings.
Exceeding the rating(s) may cause the device breakdown, damage or deterioration, and may result injury by explosion or combustion.
- (2) Use an appropriate power supply fuse to ensure that a large current does not continuously flow in case of over current and/or IC failure. The IC will fully break down when used under conditions that exceed its absolute maximum ratings, when the wiring is routed improperly or when an abnormal pulse noise occurs from the wiring or load, causing a large current to continuously flow and the breakdown can lead smoke or ignition. To minimize the effects of the flow of a large current in case of breakdown, appropriate settings, such as fuse capacity, fusing time and insertion circuit location, are required.
- (3) If your design includes an inductive load such as a motor coil, incorporate a protection circuit into the design to prevent device malfunction or breakdown caused by the current resulting from the inrush current at power ON or the negative current resulting from the back electromotive force at power OFF. IC breakdown may cause injury, smoke or ignition.
Use a stable power supply with ICs with built-in protection functions. If the power supply is unstable, the protection function may not operate, causing IC breakdown. IC breakdown may cause injury, smoke or ignition.
- (4) Do not insert devices in the wrong orientation or incorrectly.
Make sure that the positive and negative terminals of power supplies are connected properly.
Otherwise, the current or power consumption may exceed the absolute maximum rating, and exceeding the rating(s) may cause the device breakdown, damage or deterioration, and may result injury by explosion or combustion.
In addition, do not use any device that is applied the current with inserting in the wrong orientation or incorrectly even just one time.

- (5) Carefully select external components (such as inputs and negative feedback capacitors) and load components (such as speakers), for example, power amp and regulator.

If there is a large amount of leakage current such as input or negative feedback condenser, the IC output DC voltage will increase. If this output voltage is connected to a speaker with low input withstand voltage, overcurrent or IC failure can cause smoke or ignition. (The over current can cause smoke or ignition from the IC itself.) In particular, please pay attention when using a Bridge Tied Load (BTL) connection type IC that inputs output DC voltage to a speaker directly.

Points to remember on handling of ICs

- (1) Over current Protection Circuit

Over current protection circuits (referred to as current limiter circuits) do not necessarily protect ICs under all circumstances. If the Over current protection circuits operate against the over current, clear the over current status immediately.

Depending on the method of use and usage conditions, such as exceeding absolute maximum ratings can cause the over current protection circuit to not operate properly or IC breakdown before operation. In addition, depending on the method of use and usage conditions, if over current continues to flow for a long time after operation, the IC may generate heat resulting in breakdown.

- (2) Thermal Shutdown Circuit

Thermal shutdown circuits do not necessarily protect ICs under all circumstances. If the thermal shutdown circuits operate against the over temperature, clear the heat generation status immediately.

Depending on the method of use and usage conditions, such as exceeding absolute maximum ratings can cause the thermal shutdown circuit to not operate properly or IC breakdown before operation.

- (3) Heat Radiation Design

In using an IC with large current flow such as power amp, regulator or driver, please design the device so that heat is appropriately radiated, not to exceed the specified junction temperature (T_J) at any time and condition. These ICs generate heat even during normal use. An inadequate IC heat radiation design can lead to decrease in IC life, deterioration of IC characteristics or IC breakdown. In addition, please design the device taking into consideration the effect of IC heat radiation with peripheral components.

- (4) Back-EMF

When a motor rotates in the reverse direction, stops or slows down abruptly, a current flow back to the motor's power supply due to the effect of back-EMF. If the current sink capability of the power supply is small, the device's motor power supply and output pins might be exposed to conditions beyond maximum ratings. To avoid this problem, take the effect of back-EMF into consideration in system design.

RESTRICTIONS ON PRODUCT USE

- Toshiba Corporation, and its subsidiaries and affiliates (collectively "TOSHIBA"), reserve the right to make changes to the information in this document, and related hardware, software and systems (collectively "Product") without notice.
- This document and any information herein may not be reproduced without prior written permission from TOSHIBA. Even with TOSHIBA's written permission, reproduction is permissible only if reproduction is without alteration/omission.
- Though TOSHIBA works continually to improve Product's quality and reliability, Product can malfunction or fail. Customers are responsible for complying with safety standards and for providing adequate designs and safeguards for their hardware, software and systems which minimize risk and avoid situations in which a malfunction or failure of Product could cause loss of human life, bodily injury or damage to property, including data loss or corruption. Before customers use the Product, create designs including the Product, or incorporate the Product into their own applications, customers must also refer to and comply with (a) the latest versions of all relevant TOSHIBA information, including without limitation, this document, the specifications, the data sheets and application notes for Product and the precautions and conditions set forth in the "TOSHIBA Semiconductor Reliability Handbook" and (b) the instructions for the application with which the Product will be used with or for. Customers are solely responsible for all aspects of their own product design or applications, including but not limited to (a) determining the appropriateness of the use of this Product in such design or applications; (b) evaluating and determining the applicability of any information contained in this document, or in charts, diagrams, programs, algorithms, sample application circuits, or any other referenced documents; and (c) validating all operating parameters for such designs and applications. **TOSHIBA ASSUMES NO LIABILITY FOR CUSTOMERS' PRODUCT DESIGN OR APPLICATIONS.**
- Product is intended for use in general electronics applications (e.g., computers, personal equipment, office equipment, measuring equipment, industrial robots and home electronics appliances) or for specific applications as expressly stated in this document. Product is neither intended nor warranted for use in equipment or systems that require extraordinarily high levels of quality and/or reliability and/or a malfunction or failure of which may cause loss of human life, bodily injury, serious property damage or serious public impact ("Unintended Use"). Unintended Use includes, without limitation, equipment used in nuclear facilities, equipment used in the aerospace industry, medical equipment, equipment used for automobiles, trains, ships and other transportation, traffic signaling equipment, equipment used to control combustions or explosions, safety devices, elevators and escalators, devices related to electric power, and equipment used in finance-related fields. Do not use Product for Unintended Use unless specifically permitted in this document.
- Do not disassemble, analyze, reverse-engineer, alter, modify, translate or copy Product, whether in whole or in part.
- Product shall not be used for or incorporated into any products or systems whose manufacture, use, or sale is prohibited under any applicable laws or regulations.
- The information contained herein is presented only as guidance for Product use. No responsibility is assumed by TOSHIBA for any infringement of patents or any other intellectual property rights of third parties that may result from the use of Product. No license to any intellectual property right is granted by this document, whether express or implied, by estoppel or otherwise.
- **ABSENT A WRITTEN SIGNED AGREEMENT, EXCEPT AS PROVIDED IN THE RELEVANT TERMS AND CONDITIONS OF SALE FOR PRODUCT, AND TO THE MAXIMUM EXTENT ALLOWABLE BY LAW, TOSHIBA (1) ASSUMES NO LIABILITY WHATSOEVER, INCLUDING WITHOUT LIMITATION, INDIRECT, CONSEQUENTIAL, SPECIAL, OR INCIDENTAL DAMAGES OR LOSS, INCLUDING WITHOUT LIMITATION, LOSS OF PROFITS, LOSS OF OPPORTUNITIES, BUSINESS INTERRUPTION AND LOSS OF DATA, AND (2) DISCLAIMS ANY AND ALL EXPRESS OR IMPLIED WARRANTIES AND CONDITIONS RELATED TO SALE, USE OF PRODUCT, OR INFORMATION, INCLUDING WARRANTIES OR CONDITIONS OF MERCHANTABILITY, FITNESS FOR A PARTICULAR PURPOSE, ACCURACY OF INFORMATION, OR NONINFRINGEMENT.**
- Do not use or otherwise make available Product or related software or technology for any military purposes, including without limitation, for the design, development, use, stockpiling or manufacturing of nuclear, chemical, or biological weapons or missile technology products (mass destruction weapons). Product and related software and technology may be controlled under the Japanese Foreign Exchange and Foreign Trade Law and the U.S. Export Administration Regulations. Export and re-export of Product or related software or technology are strictly prohibited except in compliance with all applicable export laws and regulations.
- Please contact your TOSHIBA sales representative for details as to environmental matters such as the RoHS compatibility of Product. Please use Product in compliance with all applicable laws and regulations that regulate the inclusion or use of controlled substances, including without limitation, the EU RoHS Directive. TOSHIBA assumes no liability for damages or losses occurring as a result of noncompliance with applicable laws and regulations.

X-ON Electronics

Largest Supplier of Electrical and Electronic Components

Click to view similar products for [Motor/Motion/Ignition Controllers & Drivers](#) category:

Click to view products by [Toshiba](#) manufacturer:

Other Similar products are found below :

[FSB50550TB2](#) [FSBF15CH60BTH](#) [MSVCPM2-63-12](#) [MSVGW45-14-2](#) [MSVGW54-14-3](#) [MSVGW54-14-5](#) [NTE7043](#) [LA6565VR-TLM-E](#)
[LB11650-E](#) [LB1837M-TLM-E](#) [LB1845DAZ-XE](#) [LC898300XA-MH](#) [SS30-TE-L-E](#) [26700](#) [LV8281VR-TLM-H](#) [BA5839FP-E2](#) [IRAM236-1067A](#) [LA6584JA-AH](#) [LB11847L-E](#) [NCV70501DW002R2G](#) [AH293-PL-B](#) [STK672-630CN-E](#) [TND315S-TL-2H](#) [FNA23060](#) [FSB50250AB](#)
[FNA41060](#) [MSVB54](#) [MSVBTC50E](#) [MSVCPM3-54-12](#) [MSVCPM3-63-12](#) [MSVCPM4-63-12](#) [MSVTA120](#) [FSB50550AB](#)
[NCV70501DW002G](#) [LC898301XA-MH](#) [LV8413GP-TE-L-E](#) [MSVGW45-14-3](#) [MSVGW45-14-4](#) [MSVGW45-14-5](#) [MSVGW54-14-4](#)
[STK984-091A-E](#) [MP6519GQ-Z](#) [LB11651-E](#) [IRSM515-025DA4](#) [LV8127T-TLM-H](#) [MC33812EKR2](#) [NCP81382MNTXG](#) [TDA21801](#)
[LB11851FA-BH](#) [NCV70627DQ001R2G](#)