

BiCD Integrated Circuit Silicon Monolithic

TB62213AFG

PHASE-in controlled Bipolar Stepping Motor Driver IC

The TB62213AFG is a two-phase bipolar stepping motor driver using a PWM chopper. Fabricated with the BiCD process, the TB62213AFG is rated at 40 V/3.0 A. The on-chip voltage regulator allows control of a stepping motor with a single VM power supply.

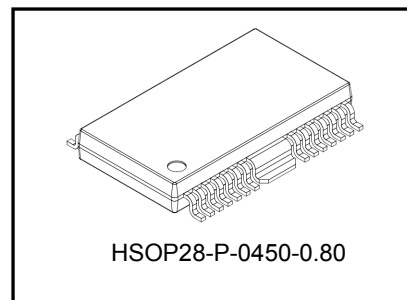

Weight: 0.79g(Typ.)

Features

- Capable of controlling 1 bipolar stepping motor.
- BiCD process integrated monolithic IC.
- PWM controlled constant-current drive.
- Allows Full Step, Half Step and 1/4 Step excitations.
- Output stage low on resistance by a BiCD process
- High voltage and current (For specification, please refer to absolute maximum ratings and operation ranges)
- Built-in error detection circuits
(Thermal shutdown (TSD), over-current shutdown (ISD), and power-on reset (POR))
- Built-in VCC regulator for internal circuit use. Therefore it's possible to operate only by a VM power supply.
- Chopping frequency of a motor can be customized by external resistance and condenser.
High-speed Chopping by more than 100 kHz is possible.
- Packages: HSOP28-P-0450-0.80

Note) Please be careful about thermal conditions during use.

Pin Assignment

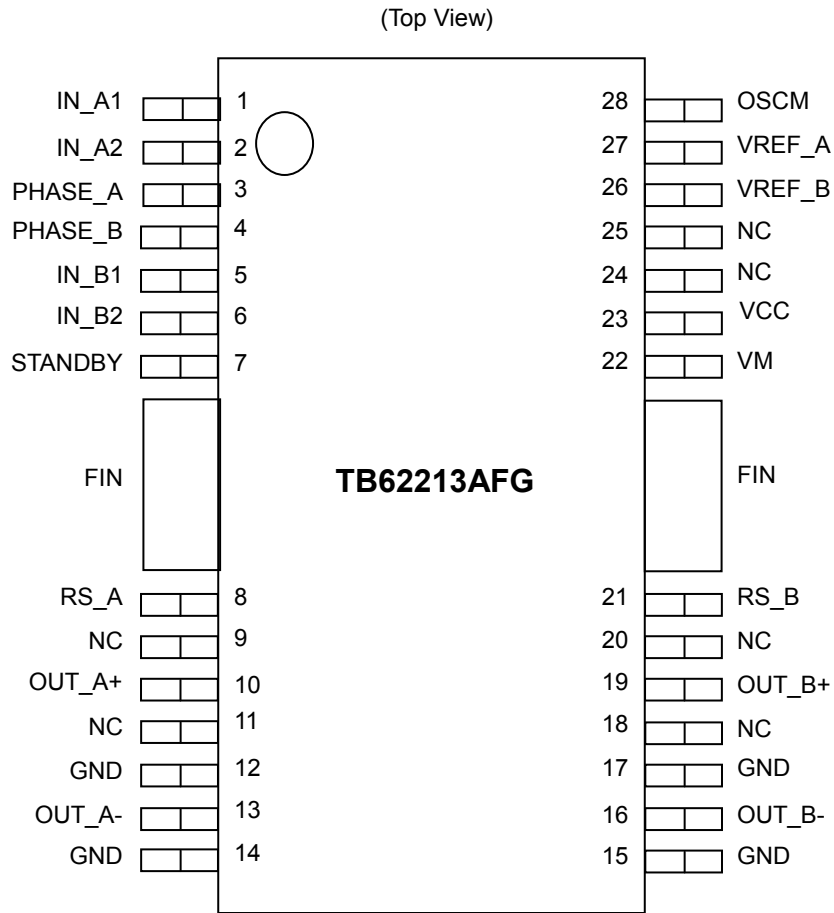

Block Diagram

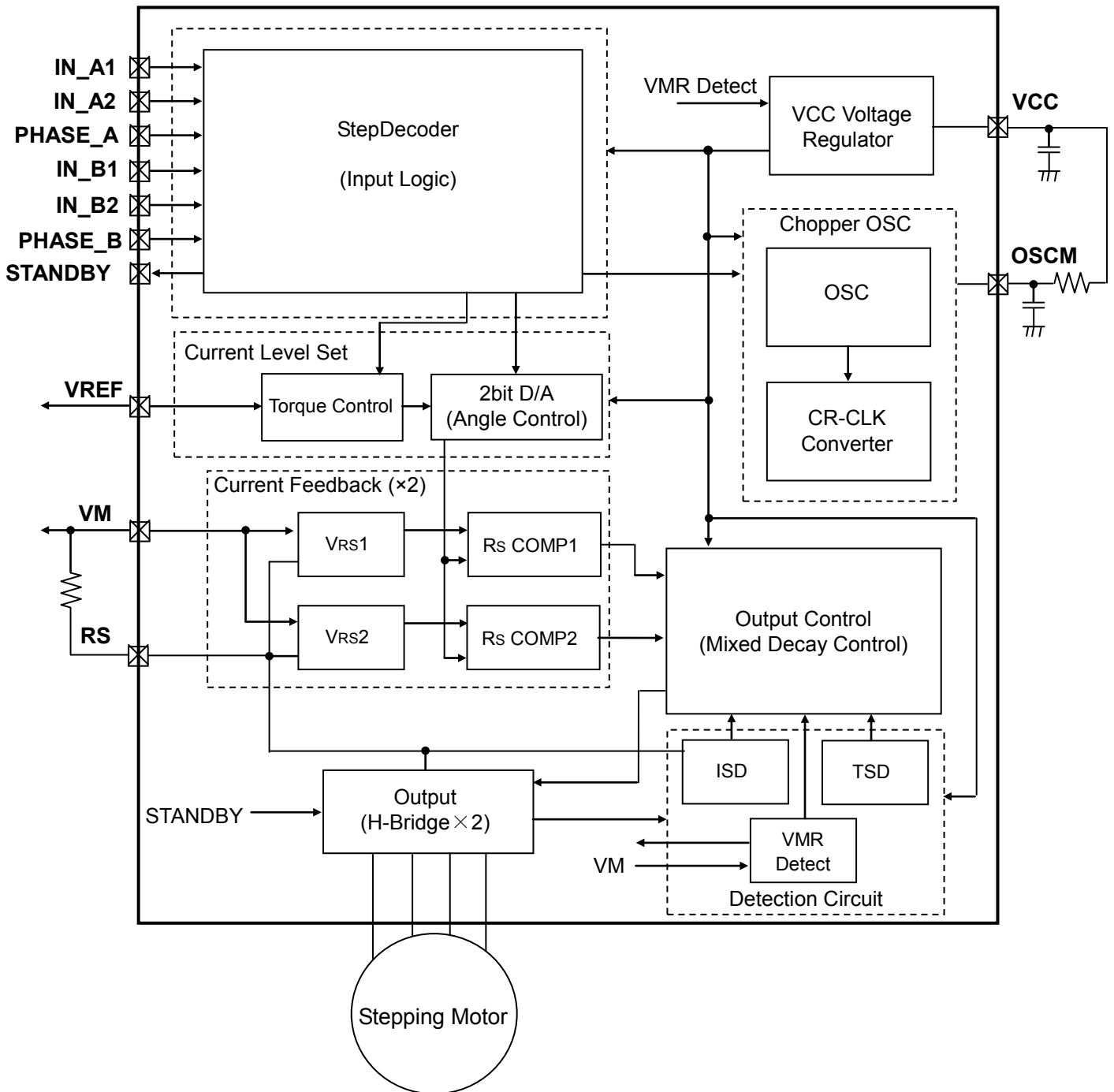

Functional blocks/circuits/constants in the block chart etc. may be omitted or simplified for explanatory purposes.

Note

All the grounding wires of this product must run on the solder within the mask of the PCM. It must also be externally terminated at a single point. Also, the grounding method should be considered for efficient heat dissipation.

Careful attention should be paid to the layout of the output, VM and GND traces, to avoid short circuits across output pins or to the power supply or ground. If such a short circuit occurs, the IC may be permanently damaged. Also, the utmost care should be taken for pattern designing and implementation of the IC since it has power supply pins (VM, RS, OUT, GND) through which a particularly large current may run. If these pins are wired incorrectly, an operation error may occur or this IC may be destroyed.

The logic input pins must be correctly wired, too. Otherwise, the IC may be damaged owing to a current running through the IC that is larger than the specified current.

Pin Function

Pin No.	Pin name	Function
1	IN_A1	Motor Ach excitation control input
2	IN_A2	Motor Ach excitation control input
3	PHASE_A	Current direction signal input for motor Ach
4	PHASE_B	Current direction signal input for motor Bch
5	IN_B1	Motor Bch excitation control input
6	IN_B2	Motor Bch excitation control input
7	STANDBY	All-function-initializing and Low power dissipation mode
8	RS_A	Motor Ach current sense pin
9	NC	Non-connection pin
10	OUT_A+	Motor Ach (+) output pin
11	NC	Non-connection pin
12	GND	Ground pin
13	OUT_A-	Motor Ach (-) output pin
14	GND	Ground pin
15	GND	Ground pin
16	OUT_B-	Motor Bch (-) output pin
17	GND	Ground pin
18	NC	Non-connection pin
19	OUT_B+	Motor Bch (+) output pin
20	NC	Non-connection pin
21	RS_B	Motor Bch current sense pin
22	VM	Motor power supply pin
23	VCC	Internal VCC regulator monitor pin
24	NC	Non-connection pin
25	NC	Non-connection pin
26	VREF_B	Motor Bch output set pin
27	VREF_A	Motor Ach output set pin
28	OSCM	Oscillating circuit frequency for chopping set pin

Please use the pin of NC with Open.

Operation explanation

IOUT: The current that flows OUT_A+(OUT_B+) to OUT_A-(OUT_B-) is defined plus current. The current that flows OUT_A-(OUT_B-) to OUT_A+(OUT_B+) is defined minus current.

<Full Step>

PHASE A				PHASE B			
Input			Output	Input			Output
PHASE_A	IN_A1	IN_A2	IOUT(A)	PHASE_B	IN_B1	IN_B2	IOUT(B)
H	H	H	100%	H	H	H	100%
L	H	H	-100%	H	H	H	100%
L	H	H	-100%	L	H	H	-100%
H	H	H	100%	L	H	H	-100%

Please make IN_A1, IN_A2, IN_B1, and IN_B2 Low when you turn on the power supply.

<Half Step>

PHASE A				PHASE B			
Input			Output	Input			Output
PHASE_A	IN_A1	IN_A2	IOUT(A)	PHASE_B	IN_B1	IN_B2	IOUT(B)
H	H	H	100%	H	H	H	100%
X	L	L	0%	H	H	H	100%
L	H	H	-100%	H	H	H	100%
L	H	H	-100%	X	L	L	0%
L	H	H	-100%	L	H	H	-100%
X	L	L	0%	L	H	H	-100%
H	H	H	100%	L	H	H	-100%
H	H	H	100%	X	L	L	0%

X: Don't care

<1/4 Step>

PHASE A				PHASE B			
Input			Output	Input			Output
PHASE_A	IN_A1	IN_A2	IOUT(A)	PHASE_B	IN_B1	IN_B2	IOUT(B)
H	H	L	71%	H	H	L	71%
H	L	H	38%	H	H	H	100%
X	L	L	0%	H	H	H	100%
L	L	H	-38%	H	H	H	100%
L	H	L	-71%	H	H	L	71%
L	H	H	-100%	H	L	H	38%
L	H	H	-100%	X	L	L	0%
L	H	H	-100%	L	L	H	-38%
L	H	L	-71%	L	H	L	-71%
L	L	H	-38%	L	H	H	-100%
X	L	L	0%	L	H	H	-100%
H	L	H	38%	L	H	H	-100%
H	H	L	71%	L	H	L	-71%
H	H	H	100%	L	L	H	-38%
H	H	H	100%	X	L	L	0%
H	H	H	100%	H	L	H	38%

X: Don't care

Other Functions

Pin Name	H	L	Notes
IN_A1 IN_A2 IN_B1 IN_B2	Outputs enabled	Outputs disabled	When IN_A1(IN_B1), IN_A2(IN_B2) are deasserted Low, its outputs assume the high-impedance state, regardless of the state of that phase.
PHASE_A PHASE_B	OUT_A+(OUT_B+): H	OUT_A-(OUT_B-): H	When PHASE_X is High, a current normally flows from OUT_A+(OUT_B+) to OUT_A-(OUT_B-).
STANDBY	Normal operation mode	Standby mode	When STANDBY is Low, both the oscillator and output drivers are disabled. Cannot drive a motor.

Protection Features

(1) Thermal shutdown (TSD)

The thermal shutdown circuit turns off all the outputs when the junction temperature (T_j) exceeds 150°C (typ.). The outputs retain the current states.

The TB62213AFG exits TSD mode and resumes normal operation when the TB62213AFG is rebooted or both the STANDBY pin are switched to 'H' → 'L' → 'H'.

(2) POR for VMR and VCCR (Power-ON-resets: VM and VCC voltage monitor)

The outputs are forced off until VM and VCC reach the rated voltages.

(3) Overcurrent shutdown (ISD)

Each phase has an overcurrent shutdown circuit, which turns off the corresponding outputs when the output current exceeds the shutdown trip threshold (above the maximum current rating: 3.0 A minimum).

The TB62213AFG exits ISD mode and resumes normal operation when the TB62213AFG is rebooted or both the STANDBY pin are switched to Low.

This circuit provides protection against a short circuit by temporarily disabling the device. Important notes on this feature will be provided later.

Absolute Maximum Ratings (Ta = 25°C)

Characteristics	Symbol	Rating	Unit
Motor power supply	V _M	40	V
Motor output voltage	V _{OUT}	40	V
Motor output current(Note1)	I _{OUT}	3.0	A
Logic input voltage	V _{IN}	6.0	V
VREF reference voltage	V _{REF}	5.0	V
Power dissipation (Note 2)	P _D	1.15	W
Operating temperature	T _{opr}	-20 to 85	°C
Storage temperature	T _{stg}	-55 to 150	°C
Junction temperature	T _j	150	°C

Note 1: The absolute maximum rating is 3.0A.

Note 2: Stand-alone (Ta = 25°C)

When Ta exceeds 25°C, it is necessary to do the derating with 9.2 mW/°C.

Ta: Ambient temperature

T_{opr}: Ambient temperature while the IC is active

T_j: Junction temperature while the IC is active. The maximum junction temperature is limited by the thermal shutdown (TSD) circuitry.

About Absolute Maximum Ratings

The absolute maximum ratings of a semiconductor device are a set of ratings that must not be exceeded, even for a moment. Do not exceed any of these ratings.

Exceeding the rating (s) may cause device breakdown, damage or deterioration, and may result in injury by explosion or combustion.

The value of even one parameter of the absolute maximum ratings should not be exceeded under any circumstances. The TB62213AFG does not have overvoltage protection. Therefore, the device is damaged if a voltage exceeding its rated maximum is applied.

All voltage ratings, including supply voltages, must always be followed. The other notes and considerations described later should also be referred to.

Operating Ranges (Note1)

Characteristics	Symbol	Test Condition	Min	Typ.	Max	Unit
Motor power supply	V_M	-	10.0	24.0	38.0	V
Motor output voltage	I_{OUT}	Ta = 25°C, Per phase	-	1.8	2.4	A
Logic input voltage	$V_{IN(H)}$	Logic high level	2.0	3.3	5.5	V
	$V_{IN(L)}$	Logic low level	GND	-	0.8	V
PHASE signal input frequency(Note2)	f_{PHASE}	-	1.0	-	400	kHz
Chopper frequency	f_{chop}	-	40	100	150	kHz
VREFreference voltage	V_{REF}	-	GND	-	3.6	V

Note 1: Please have and use the margin for the absolute maximum rating.

Note 2: There is no problem in the condition of 500ns or less at the risetime of the CLK signal even if a frequency less than it is input though the lower bound of the frequency of the input of the signal of the CLK input is assumed to be 1kHz.

Please note that repeated input of the signal by chattering can be generated when standing up of the signal becomes duller.

Electrical Characteristics 1 (Ta = 25°C, V_M = 24 V, unless otherwise specified)

Characteristics		Symbol	Test Condition	Min	Typ.	Max	Unit
Logic input voltage		V _{IH}	Logic input pins	2.0	3.3	5.5	V
		V _{IL}		GND	-	0.8	
Input hysteresis voltage		V _{IN(HIS)}	Logic input pins (Note1)	100	200	300	mV
Logic input current	High	I _{IN(H)}	Logic input pins, V _{IN} = 5 V	35	50	75	μA
	Low	I _{IN(L)}	Logic input pins, V _{IN} = 0 V	-	-	1	
Power consumption		I _{M1}	Outputs: open, non-operation STANDBY = Low	-	2.0	3.0	mA
		I _{M2}	Outputs: open, non-operation STANDBY = High f _{PHASE} =1kHz	-	3.5	5.0	
		I _{M3}	Outputs: open, two-phase excitation STANDBY = High f _{PHASE} =4kHz, f _{chop} =100kHz	-	5.0	7.0	
Output leakage current	High-side	I _{OH}	V _{RS} = V _M = 40V, V _{OUT} = 0V IN_A1=IN_A2=IN_B1=IN_B2=Low	-	-	1	μA
	Low-side	I _{OL}	V _{RS} = V _M = V _{OUT} = 40V IN_A1=IN_A2=IN_B1=IN_B2=Low	1	-	-	
Chanel-to-channel current differential		ΔI _{OUT1}	I _{OUT} = 2.0A	-5	0	+5	%
Output current error relative to the predetermined value		ΔI _{OUT2}	I _{OUT} = 2.0A	-5	0	+5	%
R _S pin current		I _{RS}	V _{RS} = V _M = 24V STANDBY = Low IN_A1=IN_A2=IN_B1=IN_B2=Low	0	-	10	μA
Drain-source ON-resistance of the output transistors (upper and lower sum)		R _{ON(D-S)}	I _{OUT} = 2.0 A, T _j = 25°C	-	0.6	0.8	Ω
Chopping current		Phase	Step0	-	0	-	%
			Step1	33	38	43	%
			Step2	66	71	76	%
			Step3	-	100	-	%

Note: V_{IN(L → H)} is defined as the V_{IN} voltage that causes the outputs to change when a pin under test is gradually raised from 0 V. V_{IN(H → L)} is defined as the V_{IN} voltage that causes the outputs to change when the pin is then gradually lowered.
The difference between V_{IN(L → H)} and V_{IN(H → L)} is defined as the input hysteresis.

Electrical Characteristics 2 (Ta = 25°C, VM = 24 V, unless otherwise specified)

Characteristics	Symbol	Test Condition	Min	Typ.	Max	Unit
Supply voltage for internal circuitry	V _{CC}	I _{CC} = 5.0 mA	4.75	5.00	5.25	V
Supply current for internal circuitry	I _{CC}	-	-	2.5	5.0	mA
VREF input voltage range	V _{REF}	STANDBY = H, f _{PHASE} = 1 kHz	GND	-	3.6	V
VREF input current	I _{REF}	Output: non-operation V _{ref} = 3.0 V	-	0	1.0	μA
VREF decay rate	V _{REF(GAIN)}	V _{ref} = 2.0 V	1/4.8	1/5.0	1/5.2	-
TSD threshold (Note 1)	T _{JTSD}	-	140	150	170	°C
VM recovery voltage	V _{MR}	STANDBY = H	7.0	8.0	9.0	V
Overcurrent trip threshold (Note 2)	I _{SD}	-	3.0	4.0	5.0	A

Note 1: Thermal shutdown (TSD) circuitry

When the junction temperature of the device reaches the threshold, the TSD circuitry is tripped, causing the internal reset circuitry to turn off the output transistors.

The TSD circuitry is tripped at a temperature between 140°C (min) and 170°C (max). Once tripped, the TSD circuitry keeps the output transistors off until both the STANDBY pin are switched to Low or the TB62213AFG is rebooted. The TSD circuit is a backup function to detect a thermal error, therefore is not recommended to be used aggressively.

Note 2: Overcurrent shutdown (ISD) circuitry

When the output current reaches the threshold, the ISD circuitry is tripped, causing the internal reset circuitry to turn off the output transistors (OSCM is stopped.).

To prevent the ISD circuitry from being tripped owing to switching noise, it has a masking time of four OSCM cycles. Once tripped, it takes a maximum of four OSCM cycles to exit ISD mode and resume normal operation.

The ISD circuitry remains active until both the STANDBY pin are switched to Low or the TB62213AFG is rebooted.

The TB62213AFG remains in Standby mode while in ISD mode.

Back-EMF

While a motor is rotating, there is a timing at which power is fed back to the power supply. At that timing, the motor current recirculates back to the power supply owing to the effect of the motor back-EMF.

If the power supply does not have enough sink capability, the power supply and output pins of the device might rise above the rated voltages. The magnitude of the motor back-EMF varies with usage conditions and motor characteristics. It must be fully verified that there is no risk that the TB62213AFG or other components will be damaged or fail owing to the motor back-EMF.

Cautions on Overcurrent Shutdown (ISD) and Thermal Shutdown (TSD)

- The ISD and TSD circuits are only intended to provide temporary protection against irregular conditions such as an output short circuit; they do not necessarily guarantee complete IC safety.
- If the device is used beyond the specified operating ranges, these circuits may not operate properly: then the device may be damaged owing to an output short circuit.
- The ISD circuit is only intended to provide temporary protection against an output short circuit. If such a condition persists for a long time, the device may be damaged owing to overstress. Overcurrent conditions must be removed immediately by external hardware.

IC Mounting

Do not insert devices in the wrong orientation or incorrectly. Otherwise, it may cause device breakdown, damage and/or deterioration.

AC Electrical Characteristics (Ta = 25°C, VM = 24 V, 6.8 mH/5.7Ω)

Characteristics	Symbol	Test Condition	Min	Typ.	Max	Unit
Phase frequency	f _{PHASE}	f _{OSCM} = 1600 kHz	1.0	-	400	kHz
Minimum phase pulse width	t _{PHASE}	f _{OSCM} = 1600 kHz	100	-	-	ns
	t _{wp}		50	-	-	
	t _{wn}		50	-	-	
Output transistor switching characteristics	t _r	- PHASE to OUT	150	200	250	ns
	t _f		100	150	200	
	t _{pLH} (P) MAX		500	850	1200	
	t _{pHL} (P) MAX		500	850	1200	
	t _{pLH} (P) MIN		250	600	950	
	t _{pHL} (P) MIN		250	600	950	
Blanking time for current spike prevention	t _{BLANK}	I _{OUT} = 1.0 A	300	400	500	ns
OSC oscillation reference frequency	f _{OSCM}	C = 270 pF, R ₁ = 3.6 kΩ	1200	1600	2000	kHz
Chopper frequency range	f _{chop} (RANGE)	Outputs enabled active I _{OUT} = 1.0 A	40	100	150	kHz
Predefined chopper frequency	f _{chop}	Outputs enabled active I _{OUT} = 1.0 A f _{OSCM} = 1600 kHz	-	100	-	kHz
ISD masking time	t _{ISD} (Mask)	This time will be the number of CLK OSCM. After ISD threshold is exceeded owing to an output short circuit to power or ground	-	4	-	-
ISD on-time	t _{ISD}		-	-	8	-

Note: There is no problem in the condition of 500ns or less at the risetime of the CLK signal even if a frequency less than it is input though the lower bound of the frequency of the input of the signal of the CLK input is assumed to be 1kHz. Please note that repeated input of the signal by chattering can be generated when standing up of the signal becomes duller.

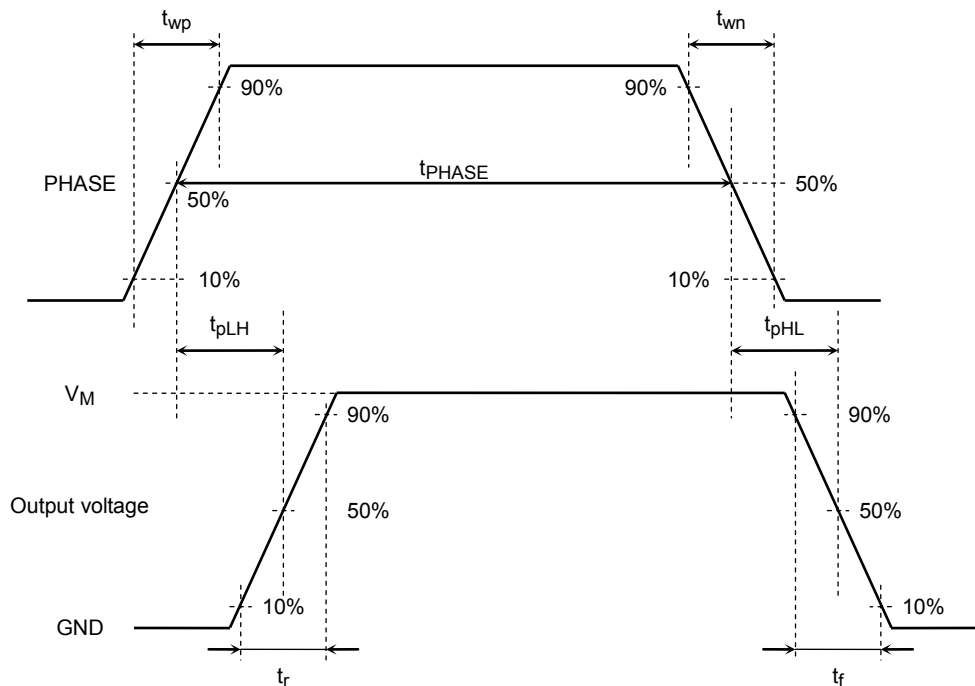
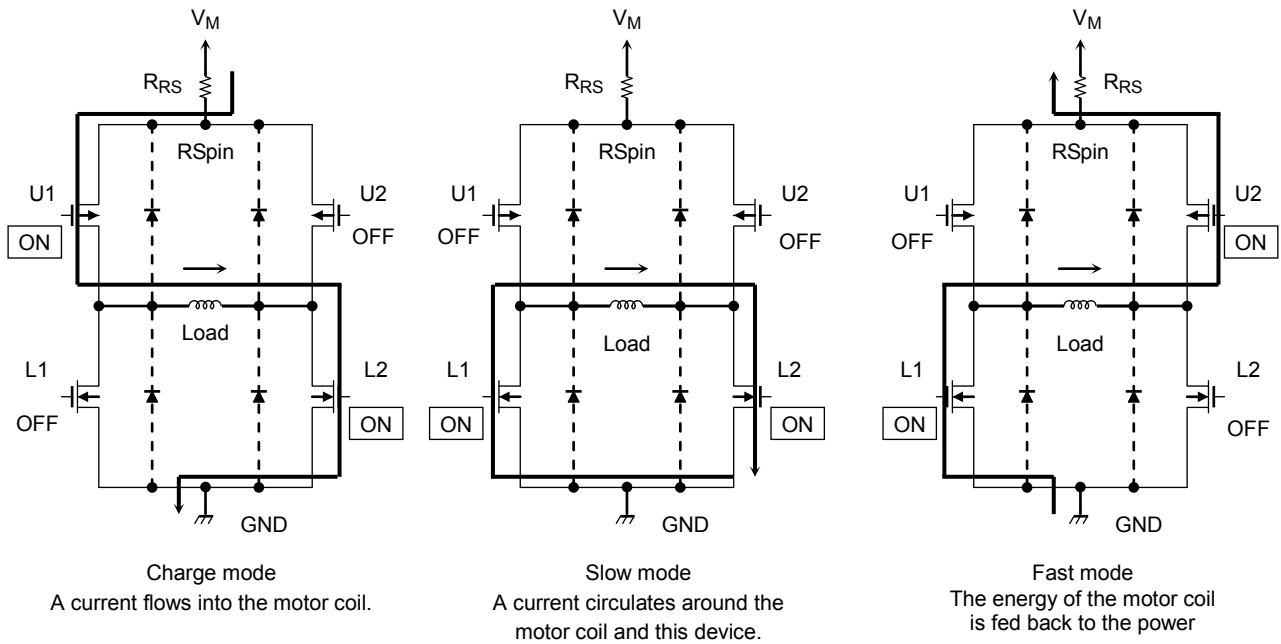

Figure 1: Timing Charts of Output Transistors Switching

Output transistor function mode



Output transistor function

MODE	U1	U2	L1	L2
CHARGE	ON	OFF	OFF	ON
SLOW	OFF	OFF	ON	ON
FAST	OFF	ON	ON	OFF

Note: This table shows an example of when the current flows as indicated by the arrows in the figures shown above. If the current flows in the opposite direction, refer to the following table.

MODE	U1	U2	L1	L2
CHARGE	OFF	ON	ON	OFF
SLOW	OFF	OFF	ON	ON
FAST	ON	OFF	OFF	ON

This IC controls the motor current to be constant by 3 modes listed above.

The equivalent circuit diagrams may be simplified or some parts of them may be omitted for explanatory purposes.

Calculation of the Predefined Output Current

For PWM constant-current control, the TB62213AFG uses a clock generated by the OSCM oscillator circuit. The peak output current can be set via the current-sensing resistor (R_{RS}) and the reference voltage (V_{REF}), as follows:

$$I_{OUT} = V_{REF}/5/R_{RS}(\Omega)$$

where, 1/5 is the V_{REF} decay rate, $V_{REF(GAIN)}$. For the value of $V_{REF(GAIN)}$, see the Electrical Characteristics table.

For example, when $V_{REF} = 3 \text{ V}$ and $I_{OUT} = 1.8 \text{ A}$. Necessary R_{RS} is $0.33 \Omega (\geq 1.1 \text{ W})$.

Calculation of the OSCM oscillation frequency (chopper reference frequency)

OSCM oscillation frequency (f_{OSCM}) and chopper frequency (f_{chop}) are computable in the following expressions.

$$f_{OSCM} = 1 / \{0.56 \times \{C \times (R_1 + 500)\}\} \quad \dots\dots\dots C, R_1: \text{External constant for OSCM } (C=270\text{pF}, R_1=3.6\text{k}\Omega)$$

$$f_{chop} = f_{OSCM} / 16$$

Phase Sequences
Full step resolution

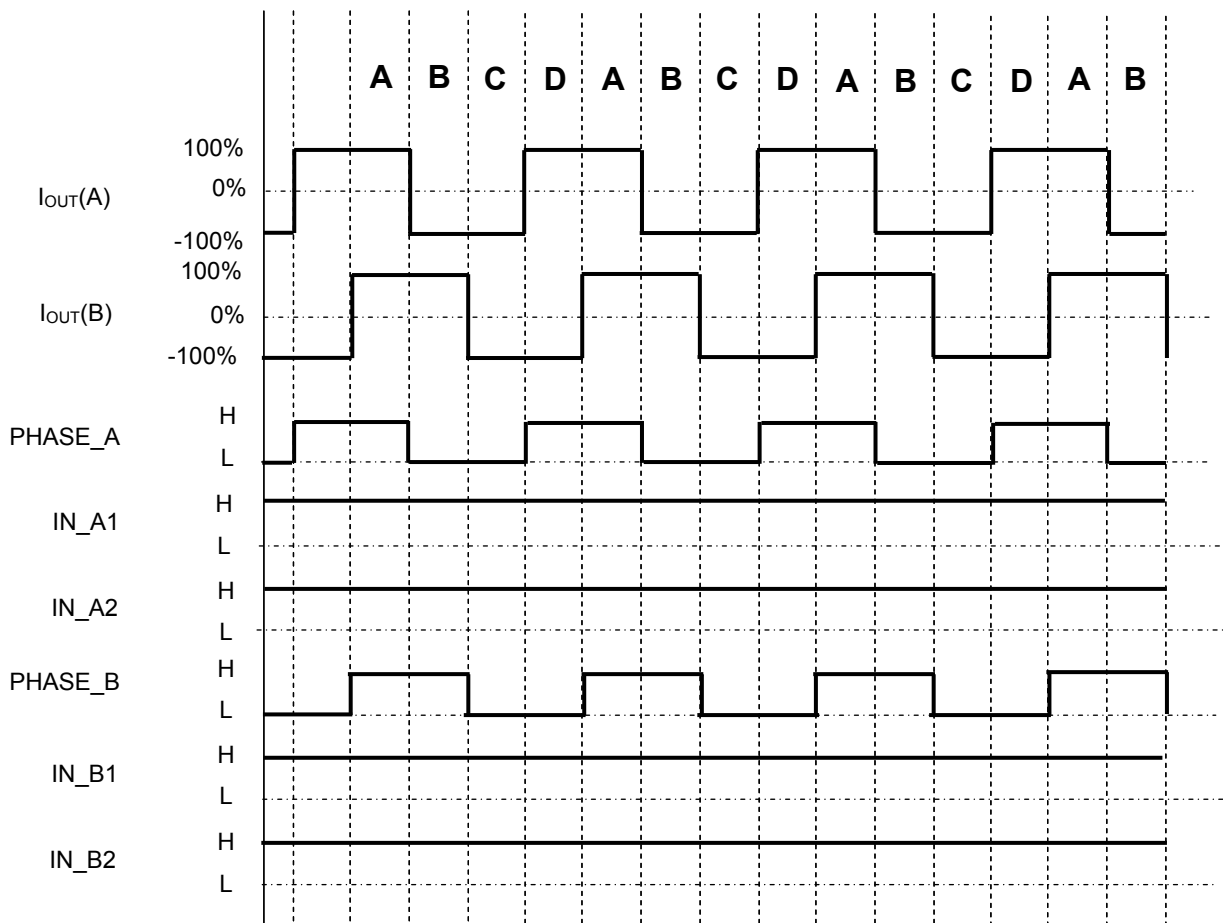
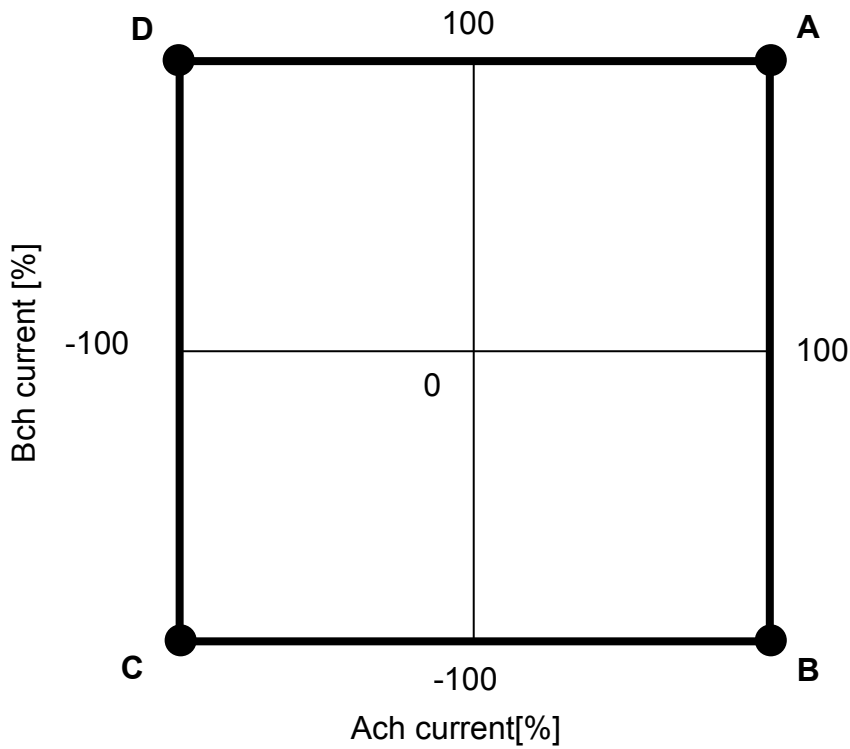

Timing charts may be simplified for explanatory purpose.
Please set IN_A1, IN_A2, IN_B1, and IN_B2 to Low until VM power supply reaches the proper operating range.

Half Step Excitation

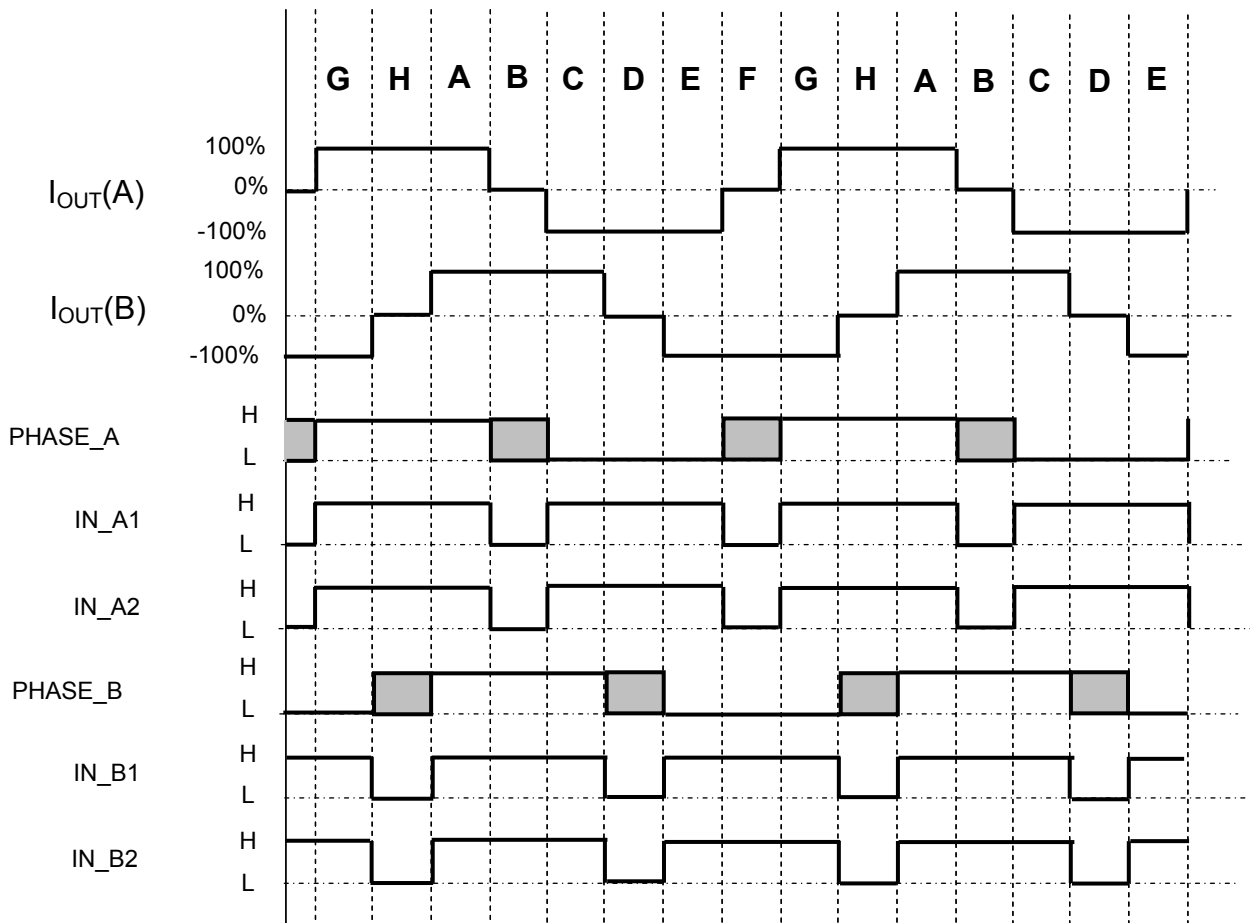
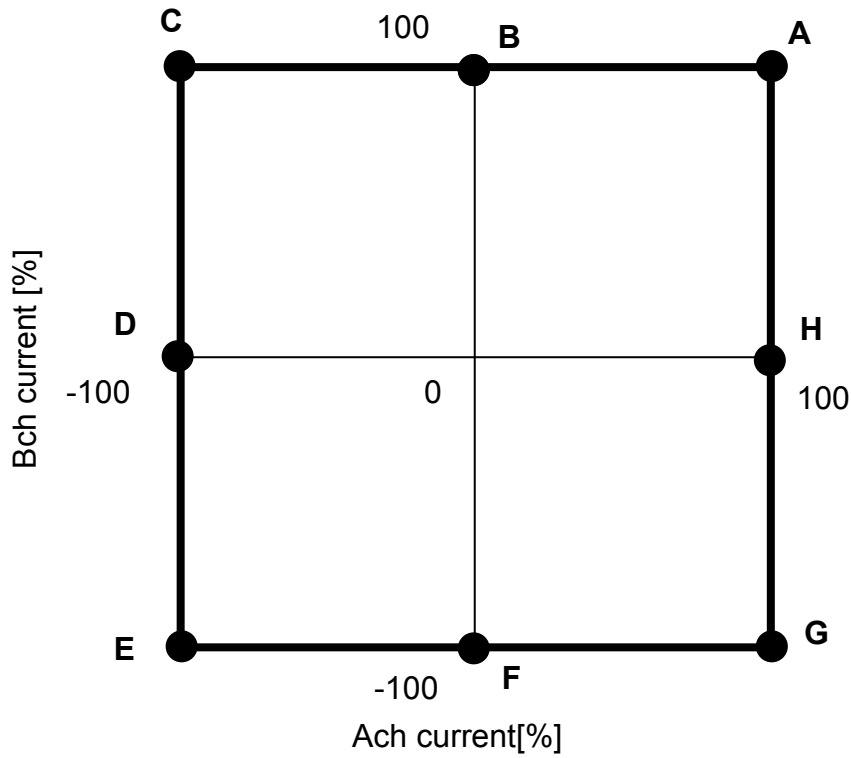

Timing charts may be simplified for explanatory purpose.

1/4 Step Excitation

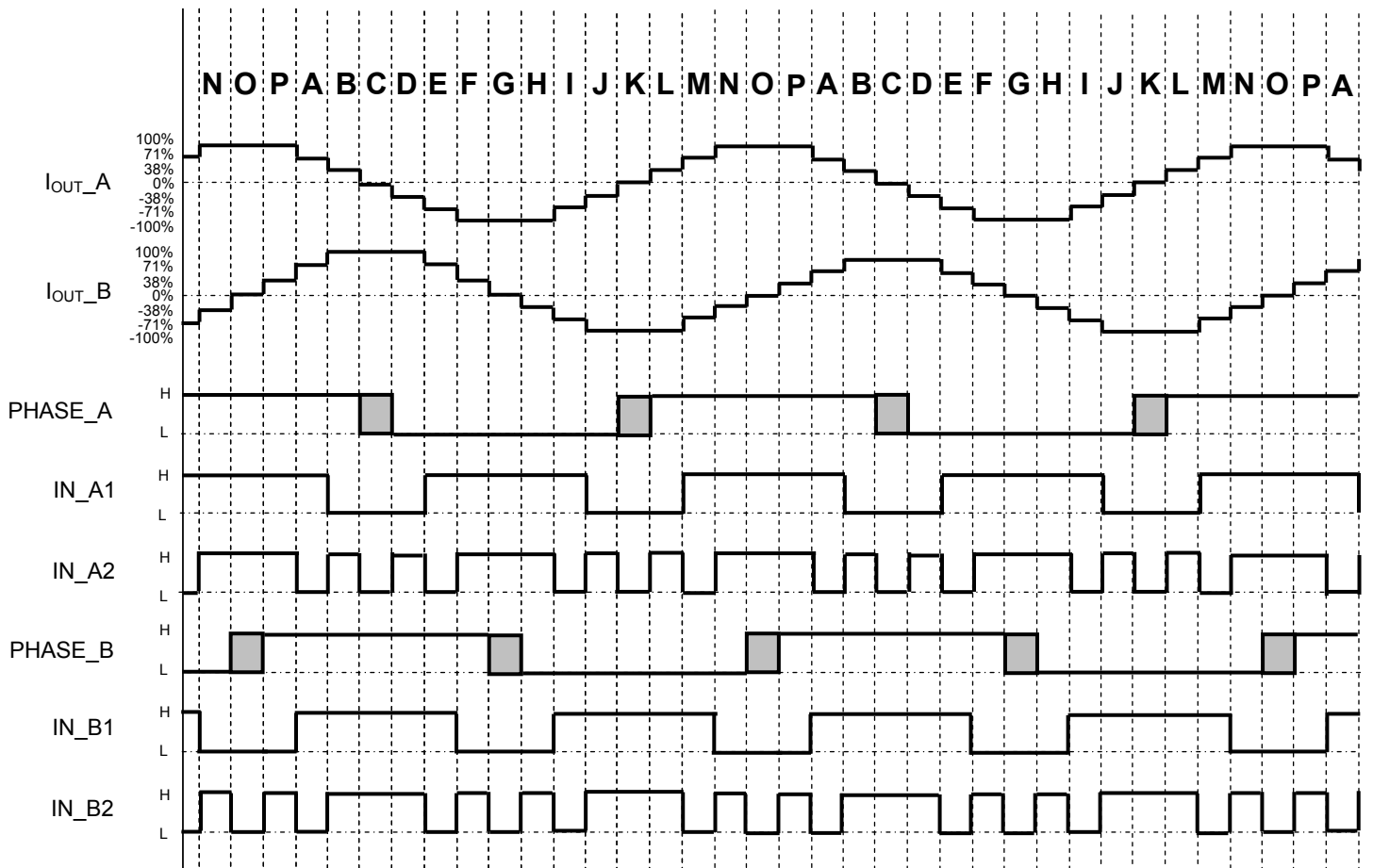
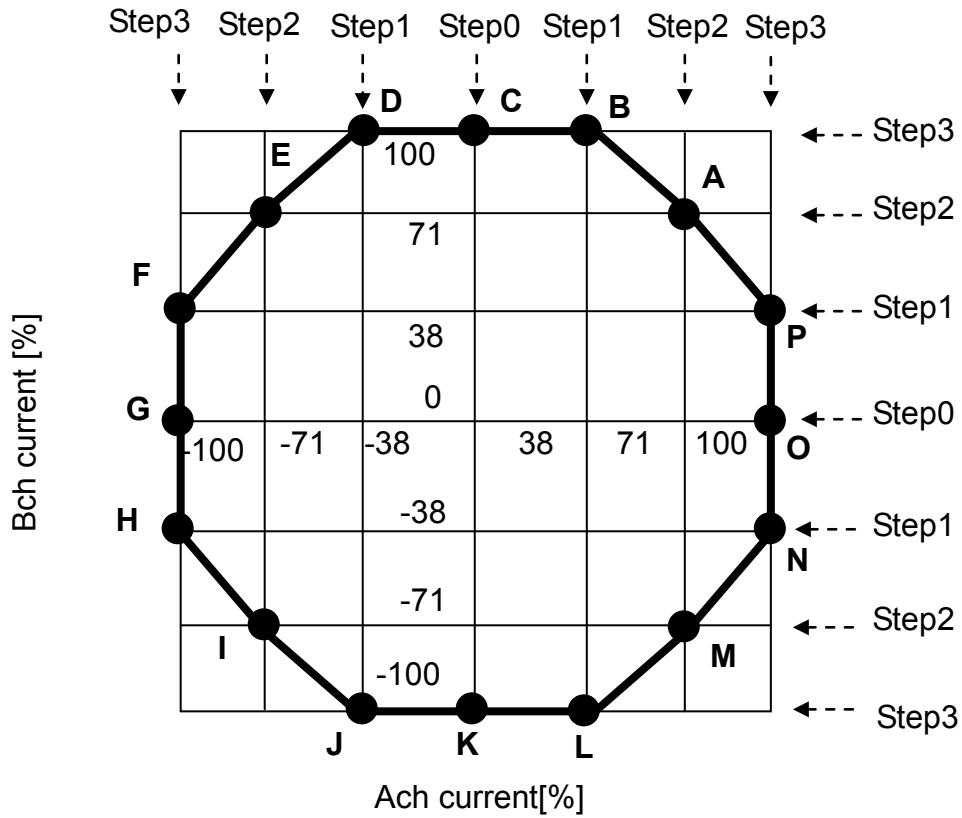

Timing charts may be simplified for explanatory purpose.

Application Circuit Example

TB62213AFG

The values shown in the following figure are typical values. For input conditions, see Operating Ranges.

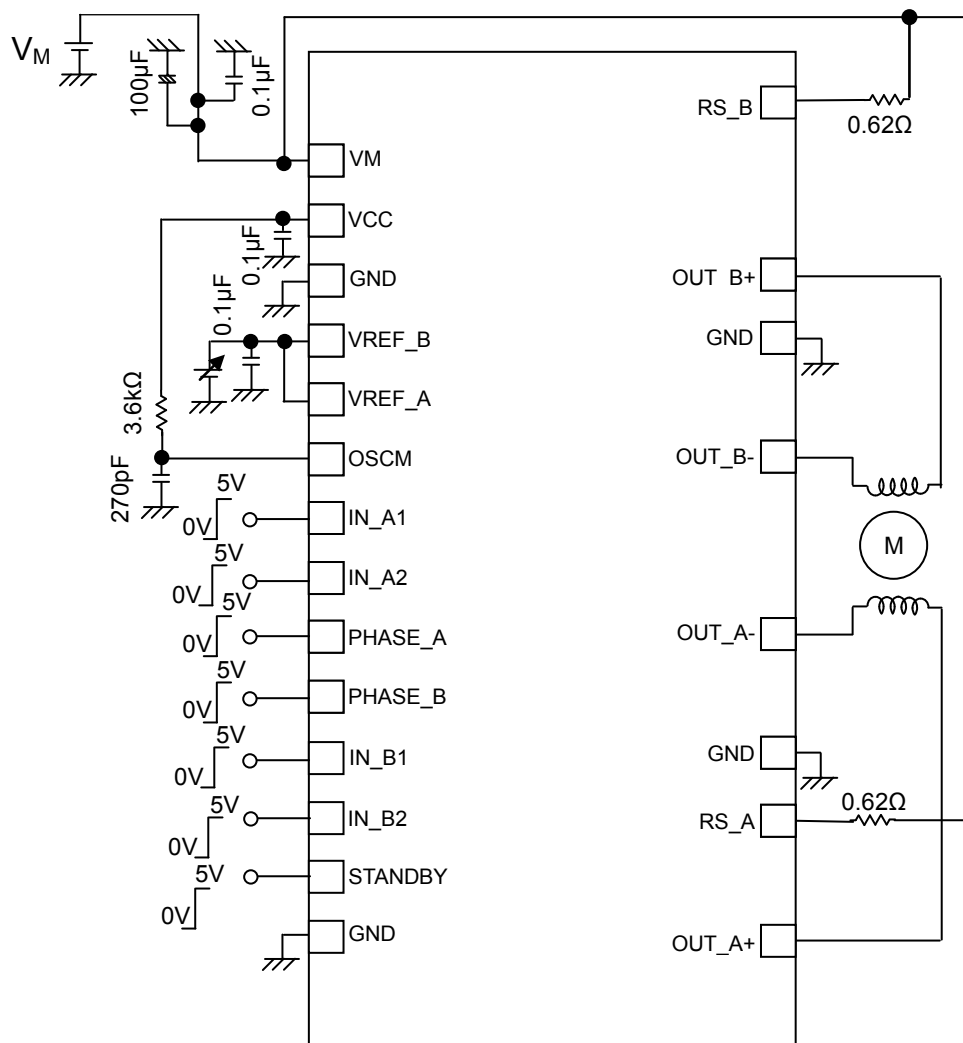

Note: Bypass capacitors should be added as necessary.

It is recommended to use a single ground plane for the entire board whenever possible, and a grounding method should be considered for efficient heat dissipation.

In cases where mode setting pins are controlled via switches, either pull-down or pull-up resistors should be added to them to avoid floating states.

For a description of the input values, see the output function tables.

The above application circuit example is presented only as a guide and should be fully evaluated prior to production. Also, no intellectual property right is ceded in any way whatsoever in regard to its use.

The external components in the above diagram are used to test the electrical characteristics of the device: it is not guaranteed that no system malfunction or failure will occur.

Careful attention should be paid to the layout of the output, V_{DD} (V_M) and GND traces to avoid short-circuits across output pins or to the power supply or ground. If such a short-circuit occurs, the TB62218AFG/AFTG may be permanently damaged. Also, if the device is installed in a wrong orientation, a high voltage might be applied to components with lower voltage ratings, causing them to be damaged. The TB62218AFG/AFTG does not have an overvoltage protection circuit. Thus, if a voltage exceeding the rated maximum voltage is applied, the TB62218AFG/AFTG will be damaged; it should be ensured that it is used within the specified operating conditions.

Package Dimensions
HSOP28-P-0450-0.80

Unit: mm

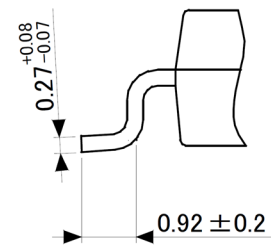
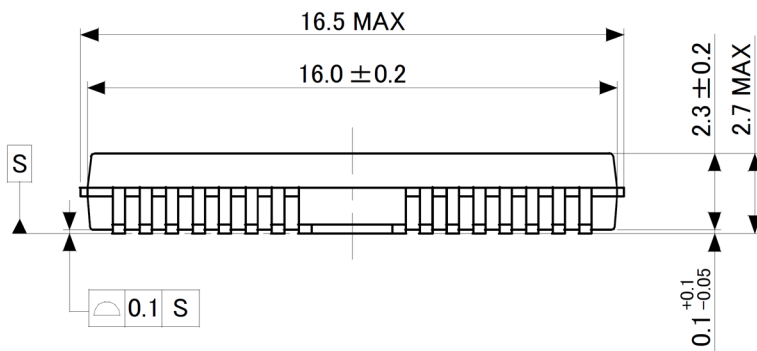
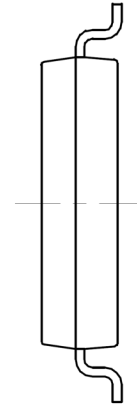
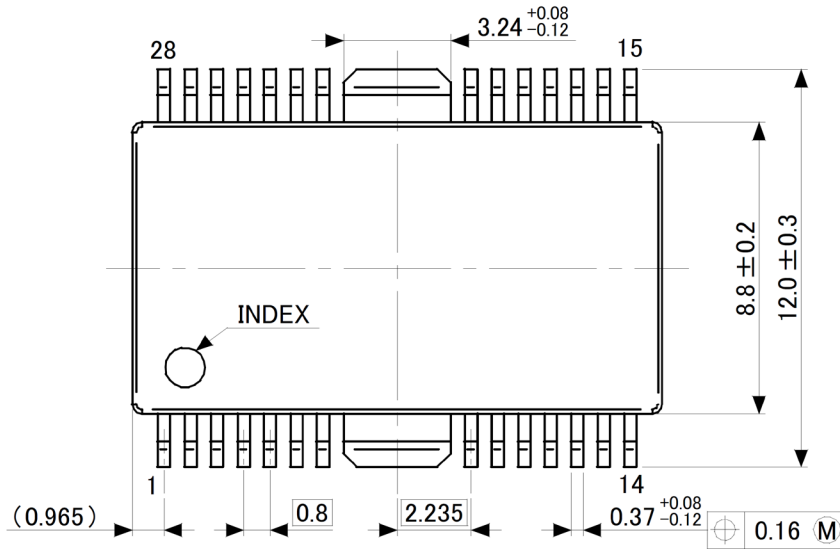

Weight: 0.79 g (typ.)

Notes on Contents

1. Block Diagrams

Some of the functional blocks, circuits, or constants in the block diagram may be omitted or simplified for explanatory purposes.

2. Equivalent Circuits

The equivalent circuit diagrams may be simplified or some parts of them may be omitted for explanatory purposes.

3. Timing Charts

Timing charts may be simplified for explanatory purposes.

4. Application Circuits

The application circuits shown in this document are provided for reference purposes only. Thorough evaluation is required at the mass production design stage. Toshiba does not grant any license to any industrial property rights by providing these examples of application circuits.

5. Test Circuits

Components in the test circuits are used only to obtain and confirm the device characteristics. These components and circuits are not guaranteed to prevent malfunction or failure from occurring in the application equipment.

IC Usage Considerations

Notes on handling of ICs

The absolute maximum ratings of a semiconductor device are a set of ratings that must not be exceeded, even for a moment. Do not exceed any of these ratings. Exceeding the rating(s) may cause device breakdown, damage or deterioration, and may result in injury by explosion or combustion.

Use an appropriate power supply fuse to ensure that a large current does not continuously flow in the case of over-current and/or IC failure. The IC will fully break down when used under conditions that exceed its absolute maximum ratings, when the wiring is routed improperly or when an abnormal pulse noise occurs from the wiring or load, causing a large current to continuously flow and the breakdown can lead to smoke or ignition. To minimize the effects of the flow of a large current in the case of breakdown, appropriate settings, such as fuse capacity, fusing time and insertion circuit location, are required.

If your design includes an inductive load such as a motor coil, incorporate a protection circuit into the design to prevent device malfunction or breakdown caused by the current resulting from the inrush current at power ON or the negative current resulting from the back electromotive force at power OFF. IC breakdown may cause injury, smoke or ignition. Use a stable power supply with ICs with built-in protection functions. If the power supply is unstable, the protection function may not operate, causing IC breakdown. IC breakdown may cause injury, smoke or ignition.

Do not insert devices in the wrong orientation or incorrectly. Make sure that the positive and negative terminals of power supplies are connected properly. Otherwise, the current or power consumption may exceed the absolute maximum rating, and exceeding the rating(s) may cause device breakdown, damage or deterioration, and may result in injury by explosion or combustion. In addition, do not use any device that has been inserted incorrectly.

Please take extra care when selecting external components (such as power amps and regulators) or external devices (for instance, speakers). When large amounts of leak current occurs from capacitors, the DC output level may increase. If the output is connected to devices such as speakers with low resist voltage, overcurrent or IC failure may cause smoke or ignition. (The over-current may cause smoke or ignition from the IC itself.) In particular, please pay attention when using a Bridge Tied Load (BTL) connection-type IC that inputs output DC voltage to a speaker directly.

Points to remember on handling of ICs

Over current detection circuit

Over current detection circuits (referred to as current limiter circuits) do not necessarily protect ICs under all circumstances. If the Over current detection circuits operate against the over current, clear the over current status immediately.

Depending on the method of use and usage conditions, such as exceeding absolute maximum ratings can cause the over current protection circuit to not operate properly or IC breakdown before operation. In addition, depending on the method of use and usage conditions, if over current continues to flow for a long time after operation, the IC may generate heat resulting in breakdown.

Thermal Shutdown Circuit

Thermal shutdown circuits do not necessarily protect ICs under all circumstances. If the thermal shutdown circuits operate against the over temperature, clear the heat generation status immediately.

Depending on the method of use and usage conditions, such as exceeding absolute maximum ratings can cause the thermal shutdown circuit to not operate properly or IC breakdown before operation.

Heat Radiation Design

In using an IC with large current flow such as power amp, regulator or driver, please design the device so that heat is appropriately radiated, not to exceed the specified junction temperature (T_j) at any time and condition. These ICs generate heat even during normal use. An inadequate IC heat radiation design can lead to decrease in IC life, deterioration of IC characteristics or IC breakdown. In addition, please design the device taking into consideration the effect of IC heat radiation with peripheral components.

Back-EMF

When a motor rotates in the reverse direction, stops or slows down abruptly, a current flow back to the motor's power supply due to the effect of back-EMF. If the current sink capability of the power supply is small, the device's motor power supply and output pins might be exposed to conditions beyond maximum ratings. To avoid this problem, take the effect of back-EMF into consideration in system design.

RESTRICTIONS ON PRODUCT USE

- Toshiba Corporation, and its subsidiaries and affiliates (collectively "TOSHIBA"), reserve the right to make changes to the information in this document, and related hardware, software and systems (collectively "Product") without notice.
- This document and any information herein may not be reproduced without prior written permission from TOSHIBA. Even with TOSHIBA's written permission, reproduction is permissible only if reproduction is without alteration/omission.
- Though TOSHIBA works continually to improve Product's quality and reliability, Product can malfunction or fail. Customers are responsible for complying with safety standards and for providing adequate designs and safeguards for their hardware, software and systems which minimize risk and avoid situations in which a malfunction or failure of Product could cause loss of human life, bodily injury or damage to property, including data loss or corruption. Before customers use the Product, create designs including the Product, or incorporate the Product into their own applications, customers must also refer to and comply with (a) the latest versions of all relevant TOSHIBA information, including without limitation, this document, the specifications, the data sheets and application notes for Product and the precautions and conditions set forth in the "TOSHIBA Semiconductor Reliability Handbook" and (b) the instructions for the application with which the Product will be used with or for. Customers are solely responsible for all aspects of their own product design or applications, including but not limited to (a) determining the appropriateness of the use of this Product in such design or applications; (b) evaluating and determining the applicability of any information contained in this document, or in charts, diagrams, programs, algorithms, sample application circuits, or any other referenced documents; and (c) validating all operating parameters for such designs and applications. **TOSHIBA ASSUMES NO LIABILITY FOR CUSTOMERS' PRODUCT DESIGN OR APPLICATIONS.**
- **PRODUCT IS NEITHER INTENDED NOR WARRANTED FOR USE IN EQUIPMENTS OR SYSTEMS THAT REQUIRE EXTRAORDINARILY HIGH LEVELS OF QUALITY AND/OR RELIABILITY, AND/OR A MALFUNCTION OR FAILURE OF WHICH MAY CAUSE LOSS OF HUMAN LIFE, BODILY INJURY, SERIOUS PROPERTY DAMAGE AND/OR SERIOUS PUBLIC IMPACT ("UNINTENDED USE").** Except for specific applications as expressly stated in this document, Unintended Use includes, without limitation, equipment used in nuclear facilities, equipment used in the aerospace industry, medical equipment, equipment used for automobiles, trains, ships and other transportation, traffic signaling equipment, equipment used to control combustions or explosions, safety devices, elevators and escalators, devices related to electric power, and equipment used in finance-related fields. **IF YOU USE PRODUCT FOR UNINTENDED USE, TOSHIBA ASSUMES NO LIABILITY FOR PRODUCT.** For details, please contact your TOSHIBA sales representative.
- Do not disassemble, analyze, reverse-engineer, alter, modify, translate or copy Product, whether in whole or in part.
- Product shall not be used for or incorporated into any products or systems whose manufacture, use, or sale is prohibited under any applicable laws or regulations.
- The information contained herein is presented only as guidance for Product use. No responsibility is assumed by TOSHIBA for any infringement of patents or any other intellectual property rights of third parties that may result from the use of Product. No license to any intellectual property right is granted by this document, whether express or implied, by estoppel or otherwise.
- **ABSENT A WRITTEN SIGNED AGREEMENT, EXCEPT AS PROVIDED IN THE RELEVANT TERMS AND CONDITIONS OF SALE FOR PRODUCT, AND TO THE MAXIMUM EXTENT ALLOWABLE BY LAW, TOSHIBA (1) ASSUMES NO LIABILITY WHATSOEVER, INCLUDING WITHOUT LIMITATION, INDIRECT, CONSEQUENTIAL, SPECIAL, OR INCIDENTAL DAMAGES OR LOSS, INCLUDING WITHOUT LIMITATION, LOSS OF PROFITS, LOSS OF OPPORTUNITIES, BUSINESS INTERRUPTION AND LOSS OF DATA, AND (2) DISCLAIMS ANY AND ALL EXPRESS OR IMPLIED WARRANTIES AND CONDITIONS RELATED TO SALE, USE OF PRODUCT, OR INFORMATION, INCLUDING WARRANTIES OR CONDITIONS OF MERCHANTABILITY, FITNESS FOR A PARTICULAR PURPOSE, ACCURACY OF INFORMATION, OR NONINFRINGEMENT.**
- Do not use or otherwise make available Product or related software or technology for any military purposes, including without limitation, for the design, development, use, stockpiling or manufacturing of nuclear, chemical, or biological weapons or missile technology products (mass destruction weapons). Product and related software and technology may be controlled under the applicable export laws and regulations including, without limitation, the Japanese Foreign Exchange and Foreign Trade Law and the U.S. Export Administration Regulations. Export and re-export of Product or related software or technology are strictly prohibited except in compliance with all applicable export laws and regulations.
- Please contact your TOSHIBA sales representative for details as to environmental matters such as the RoHS compatibility of Product. Please use Product in compliance with all applicable laws and regulations that regulate the inclusion or use of controlled substances, including without limitation, the EU RoHS Directive. **TOSHIBA ASSUMES NO LIABILITY FOR DAMAGES OR LOSSES OCCURRING AS A RESULT OF NONCOMPLIANCE WITH APPLICABLE LAWS AND REGULATIONS.**

X-ON Electronics

Largest Supplier of Electrical and Electronic Components

Click to view similar products for [Motor/Motion/Ignition Controllers & Drivers](#) category:

Click to view products by [Toshiba](#) manufacturer:

Other Similar products are found below :

[FSB50550TB2](#) [FSBF15CH60BTH](#) [MSVCPM2-63-12](#) [MSVGW45-14-2](#) [MSVGW54-14-3](#) [MSVGW54-14-5](#) [NTE7043](#) [LA6565VR-TLM-E](#)
[LB11650-E](#) [LB1837M-TLM-E](#) [LB1845DAZ-XE](#) [LC898300XA-MH](#) [SS30-TE-L-E](#) [26700](#) [LV8281VR-TLM-H](#) [BA5839FP-E2](#) [IRAM236-1067A](#) [LA6584JA-AH](#) [LB11847L-E](#) [AH293-PL-B](#) [TND315S-TL-2H](#) [FNA23060](#) [FSB50250AB](#) [FNA41060](#) [MSVB54](#) [MSVBTC50E](#)
[MSVCPM3-54-12](#) [MSVCPM3-63-12](#) [MSVCPM4-63-12](#) [MSVTA120](#) [FSB50550AB](#) [NCV70501DW002G](#) [LC898301XA-MH](#) [LV8413GP-TE-L-E](#) [MSVGW45-14-3](#) [MSVGW45-14-4](#) [MSVGW45-14-5](#) [MSVGW54-14-4](#) [STK984-091A-E](#) [SLA7026M](#) [MP6519GQ-Z](#) [LB11651-E](#)
[IRSM515-025DA4](#) [LV8127T-TLM-H](#) [MC33812EKR2](#) [NCP81382MNTXG](#) [TDA21801](#) [LB11851FA-BH](#) [NCV70627DQ001R2G](#)
[LB1938FAGEVB](#)