

TOSHIBA BiCD Integrated Circuit Silicon Monolithic

# TB67S508FTG

## BiCD Constant-Current Two-Phase Bipolar Stepping Motor Driver IC

The TB67S508FTG is a two-phase bipolar stepping motor driver using a PWM chopper.

Fabricated with the BiCD process, the TB67S508FTG rating is 40 V/3.0 A.

Motor can be operated with single power supply (VM) by built-in regulator.

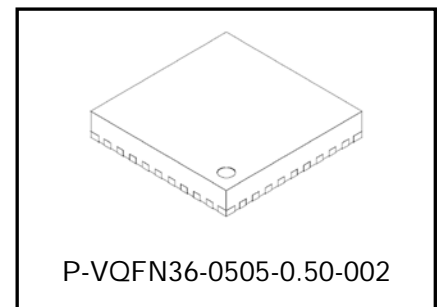

Weight: 0.06 g (Typ.)

### Features

- BiCD process monolithic IC
- Capable of controlling bipolar stepping motor
- PWM controlled constant-current drive without resistance for motor current detection
- Built-in ACDS (Advanced Current Detect System) function enables a PWM constant current control without external current detection resistors.
- Built-in ADMD(Advanced Dynamic Mixed Decay) function enables a high efficiency PWM constant current control.
- I/F: Capable of switching between the phase input control and the clock input control
- Full-step/Half-step/Quarter-step resolutions
- BiCD: DMOSFET is adopted to output power transistor.
- High withstand voltage and large current: 40 V / 3.0 A (absolute maximum ratings)
- Built-in thermal shutdown detection (TSD), Over current detection (ISD), and Under voltage lockout detection(UVLO)
- Decreasing number of external components by reducing charge pump
- Package: P-VQFN36-0505-0.50-002

## Pin Assignment

IFSEL="H" (Phase input control)

(Top View)

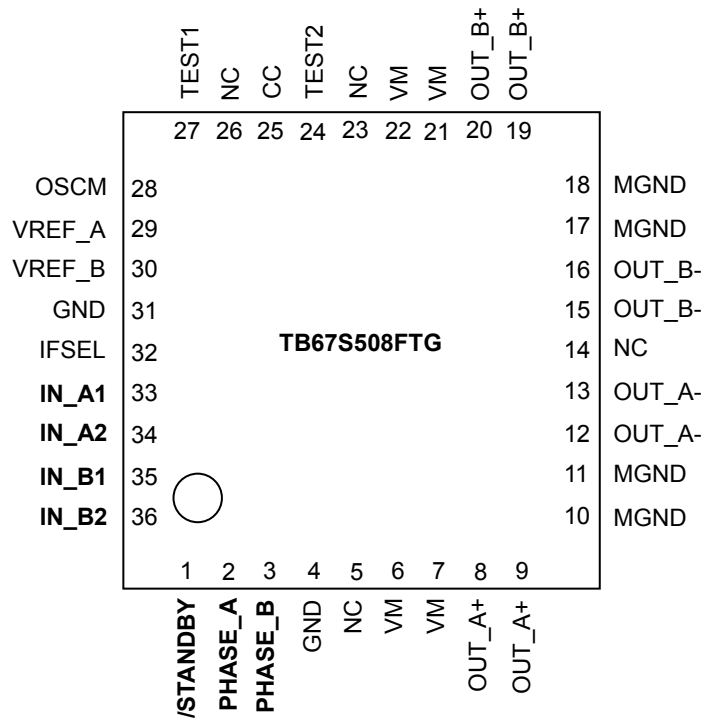

IFSEL="L" (Clock input control)

(Top View)

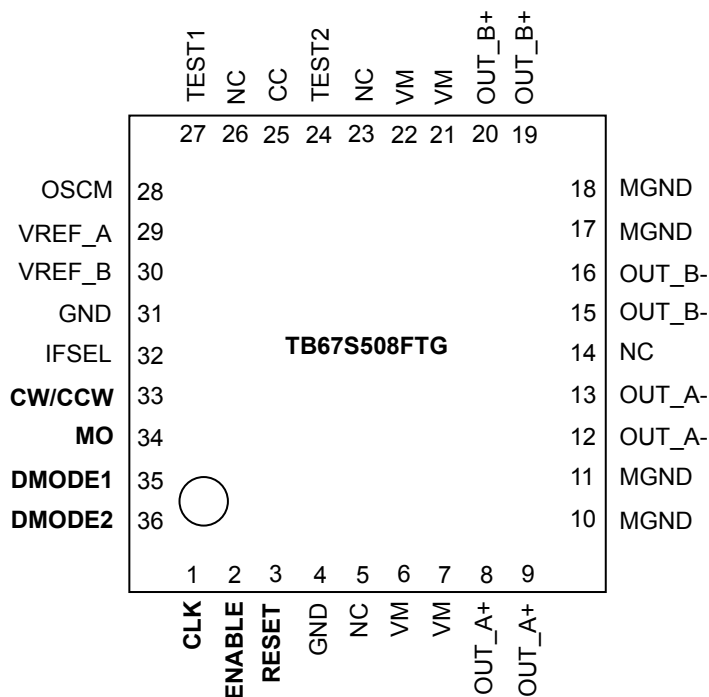

**Block Diagram**

IFSEL="H" (Phase input control)

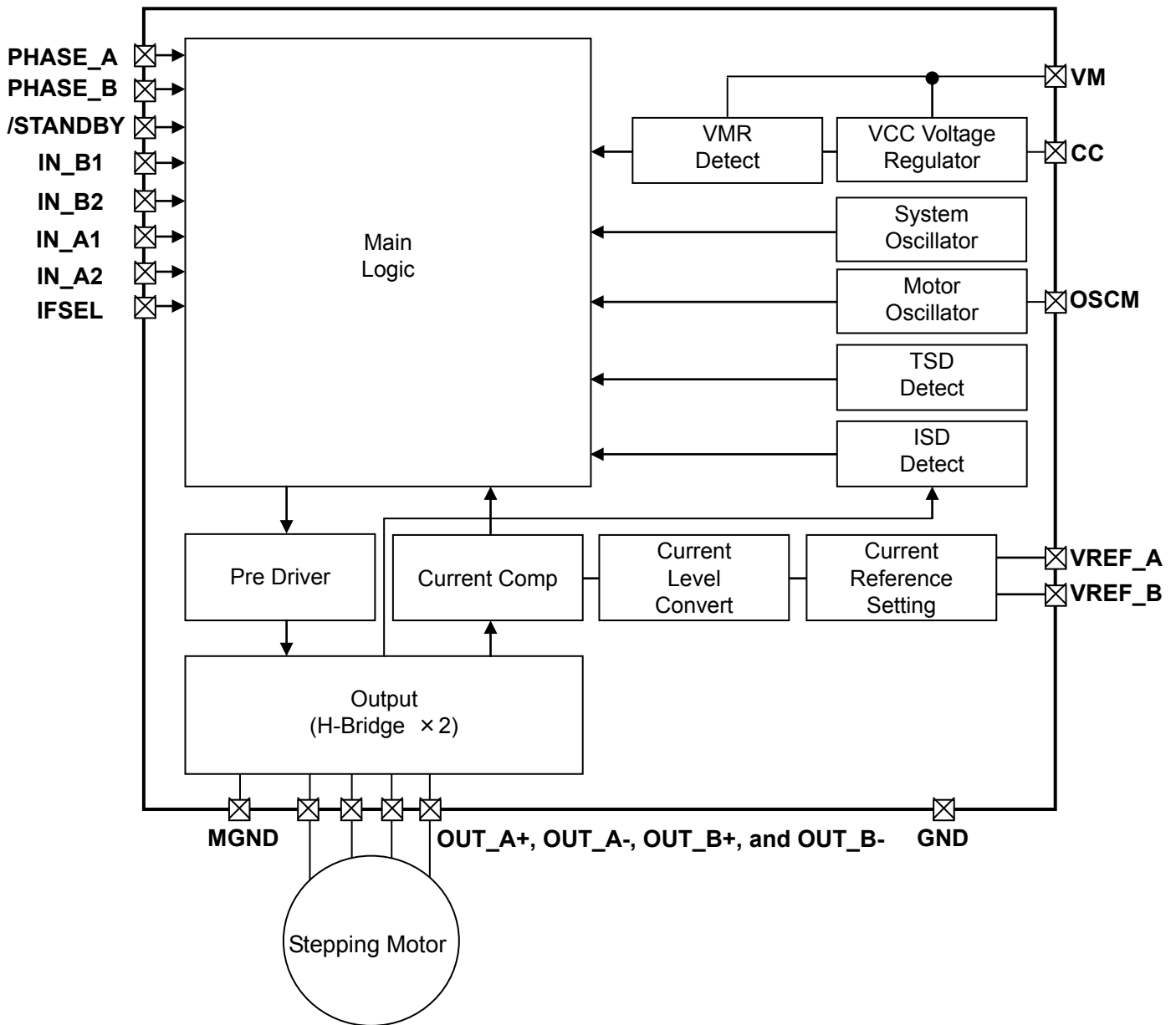

Functional blocks/circuits/constants in the block chart etc. may be omitted or simplified for explanatory purposes.

Note: All the grounding wires of the TB67S508FTG should run on the solder mask on the PCB and be externally terminated at only one point. Also, a grounding method should be considered for efficient heat dissipation.

Careful attention should be paid to the layout of the output, VM and GND traces, to avoid short circuits across output pins or to the power supply or ground. If such a short circuit occurs, the device may be permanently damaged.

Also, the utmost care should be taken for pattern designing and implementation of the device since it has power supply pins (VM, OUT\_A+, OUT\_A-, OUT\_B+, OUT\_B-, GND, and MGND) through which a particularly large current may run. If these pins are wired incorrectly, an operation error may occur or the device may be destroyed.

The logic input pins must also be wired correctly. Otherwise, the device may be damaged owing to a current running through the IC that is larger than the specified current.

Careful attention should be paid to design patterns and mountings.

## Pin Explanations

IFSEL="H" (Phase input control)

Pin No.	Pin Name	Function
1	/STANDBY	Standby signal input pin
2	PHASE_A	Control signal input pin for Ach motor output
3	PHASE_B	Control signal input pin for Bch motor output
4	GND	Ground pin
5	NC	Non-connection pin
6	VM	Motor power supply pin
7	VM	Motor power supply pin
8	OUT_A+	Motor Ach (+) output pin
9	OUT_A+	Motor Ach (+) output pin
10	MGND	Motor ground pin
11	MGND	Motor ground pin
12	OUT_A-	Motor Ach (-) output pin
13	OUT_A-	Motor Ach (-) output pin
14	NC	Non-connection pin
15	OUT_B-	Motor Bch (-) output pin
16	OUT_B-	Motor Bch (-) output pin
17	MGND	Motor ground pin
18	MGND	Motor ground pin
19	OUT_B+	Motor Bch (+) output pin
20	OUT_B+	Motor Bch (+) output pin
21	VM	Motor power supply pin
22	VM	Motor power supply pin
23	NC	Non-connection pin
24	TEST2	Toshiba test pin for shipment (please set open in using.)
25	CC	Monitor pin for internal regulator
26	NC	Non-connection pin
27	TEST1	Toshiba test pin for shipment (please set GND in using.)
28	OSCM	Frequency set pin for internal oscillation circuit
29	VREF_A	Current set pin for Ach motor output
30	VREF_B	Current set pin for Bch motor output
31	GND	Ground pin
32	IFSEL	I/F mode set pin
33	IN_A1	Control signal input pin for Ach motor output
34	IN_A2	Control signal input pin for Ach motor output
35	IN_B1	Control signal input pin for Bch motor output
36	IN_B2	Control signal input pin for Bch motor output

\* NC: Please set open.

\* Please connect the pins with the same pin name nearby.

## IFSEL="L" (Clock input control)

Pin No.	Pin Name	Function
1	CLK	Clock signal input pin for electrical-angle step
2	ENABLE	Signal input pin for switching output (ON/OFF)
3	RESET	Signal input pin for initialization of electrical angle
4	GND	Ground pin
5	NC	Non-connection pin
6	VM	Motor power supply pin
7	VM	Motor power supply pin
8	OUT_A+	Motor Ach (+) output pin
9	OUT_A+	Motor Ach (+) output pin
10	MGND	Motor ground pin
11	MGND	Motor ground pin
12	OUT_A-	Motor Ach (-) output pin
13	OUT_A-	Motor Ach (-) output pin
14	NC	Non-connection pin
15	OUT_B-	Motor Bch (-) output pin
16	OUT_B-	Motor Bch (-) output pin
17	MGND	Motor ground pin
18	MGND	Motor ground pin
19	OUT_B+	Motor Bch (+) output pin
20	OUT_B+	Motor Bch (+) output pin
21	VM	Motor power supply pin
22	VM	Motor power supply pin
23	NC	Non-connection pin
24	TEST2	Toshiba test pin for shipment (please set open in using.)
25	CC	Monitor pin for internal regulator
26	NC	Non-connection pin
27	TEST1	Toshiba test pin for shipment (please set GND in using.)
28	OSCM	Frequency set pin for internal oscillation circuit
29	VREF_A	Current set pin for Ach motor output
30	VREF_B	Current set pin for Bch motor output
31	GND	Ground pin
32	IFSEL	I/F mode set pin
33	CW/CCW	Signal input pin for rotation direction set
34	MO	Electrical angle monitor pin (Open-drain output)
35	DMODE1	Excitation mode set pin
36	DMODE2	Excitation mode set pin

\* NC: Please set open.

\* Please connect the pins with the same pin name nearby.

**Input/Output Equivalent Circuit**

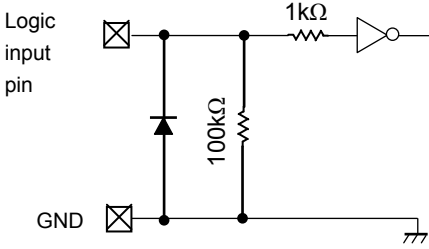
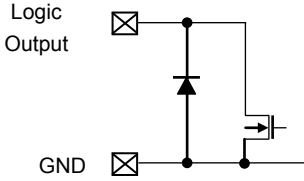
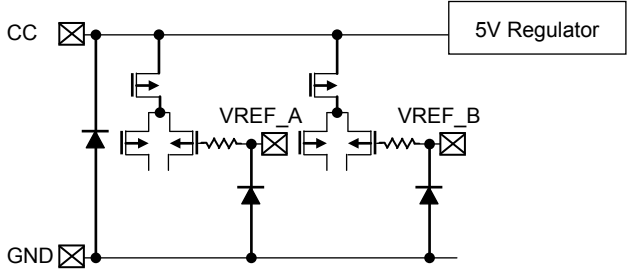
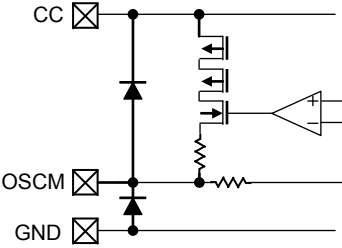
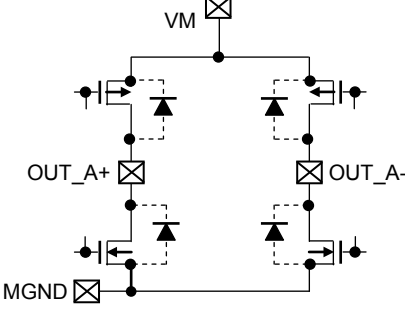
Pin name	Equivalent circuit
/STANDBY (CLK) PHASE_A (ENABLE) PHASE_B (RESET) IN_A1 (CW/CCW) IN_A2 IN_B1 (DMODE1) IN_B2 (DMODE2) IFSEL	
MO	
CC VREF_A VREF_B	
OSCM	
VM OUT_A+ OUT_A- OUT_B+ OUT_B- MGND	 <p>* OUT_B+, OUT_B-: Same</p>

\* The equivalent circuit diagrams may be simplified or some parts of them may be omitted for explanatory purposes.

**Operation Description**

- IFSEL="H" (Phase input control)

**Functions of IN\_A1, IN\_A2, IN\_B1, IN\_B2, PHASE\_A, and PHASE\_B**

Input			Output		
PHASE_A PHASE_B	IN_A1 IN_B1	IN_A2 IN_B2	OUT_A+ OUT_B+	OUT_A- OUT_B-	IOUT
H	H	H	H	L	100%
	H	L	H	L	71%
	L	H	H	L	38%
	L	L	Output OFF	Output OFF	0%
L	H	H	L	H	-100%
	H	L	L	H	-71%
	L	H	L	H	-38%
	L	L	Output OFF	Output OFF	0%

Definition of current flowing direction at IOUT:  
 From OUT\_A+ (OUT\_B+) to OUT\_A-(OUT\_B-): Plus current  
 From OUT\_A-(OUT\_B-) to OUT\_A+ (OUT\_B+): Minus current

**Function of /STANDBY**

The operation can resume from the forced off mode, which is configured by the thermal shutdown detection (TSD) and the over current detection (ISD), by setting standby mode once and then setting the normal operation mode again.

Input	Output
/STANDBY	OUT_A+, OUT_B+, OUT_A-, OUT_B-
H	Normal operation mode
L	Standby mode (Internal oscillation circuit (OSCM) and MOSFET output: OFF)

**Sequence in each Drive Mode: IFSEL="H" (phase input control)**

**Full-step resolution**

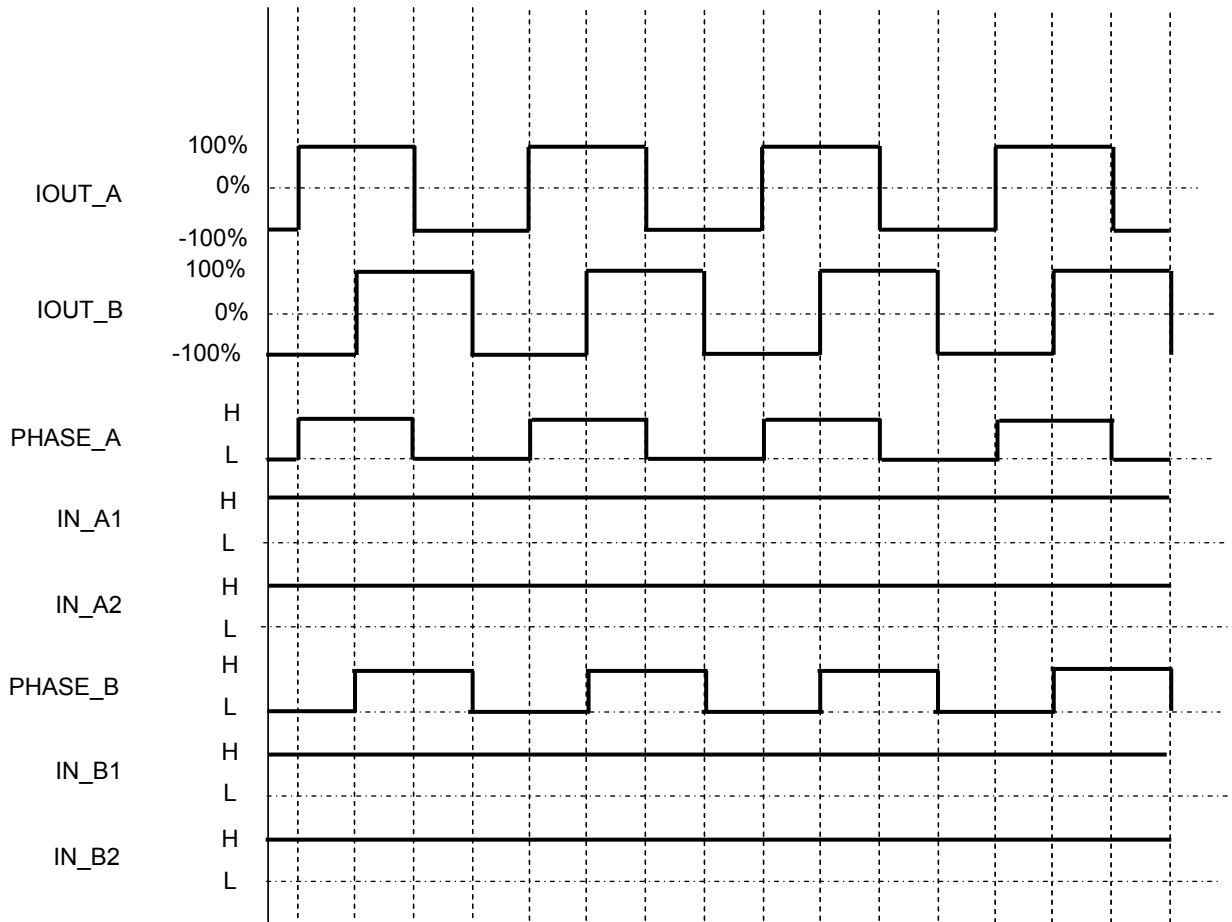

Timing charts may be simplified for explanatory purpose.



**Half-step resolution**

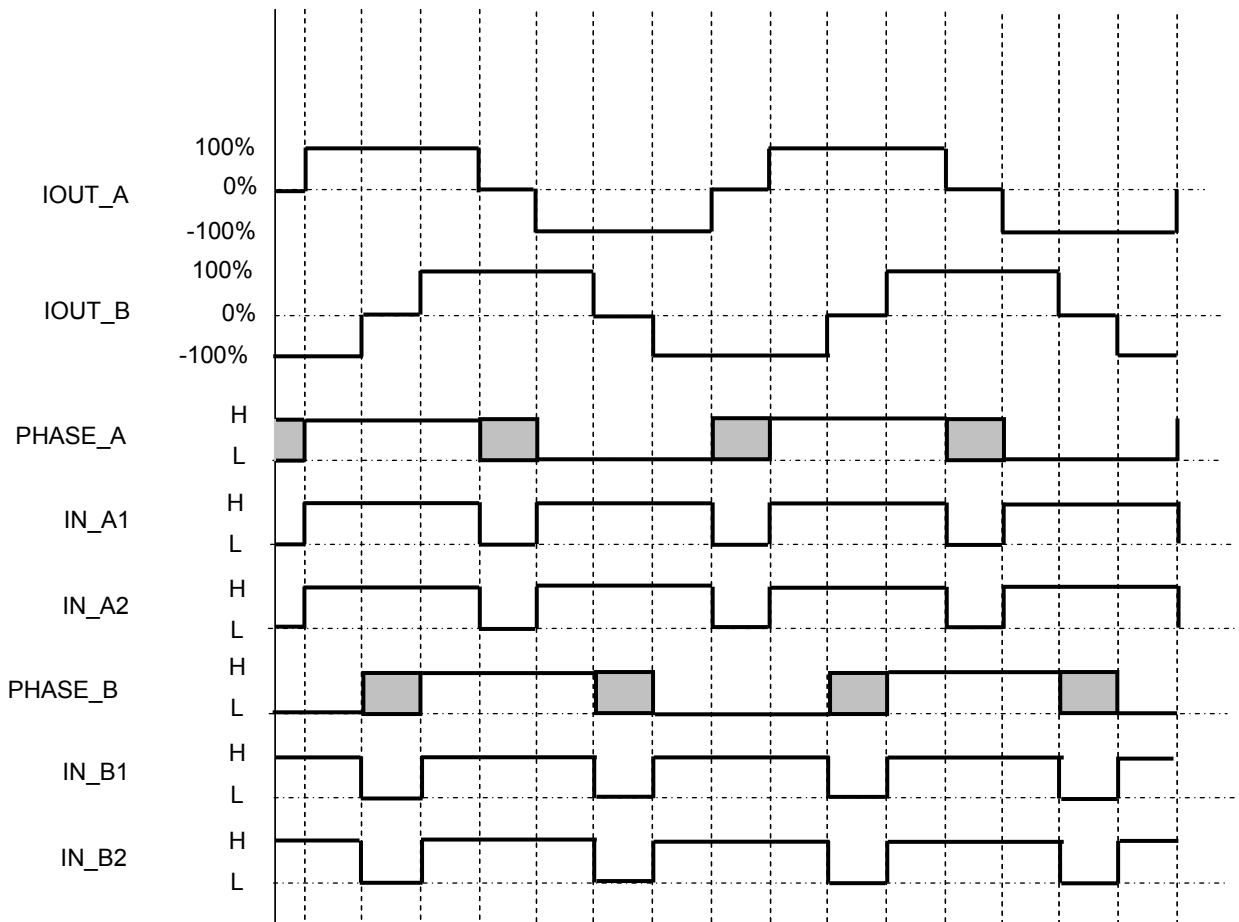

Timing charts may be simplified for explanatory purpose.

## Quarter-step resolution

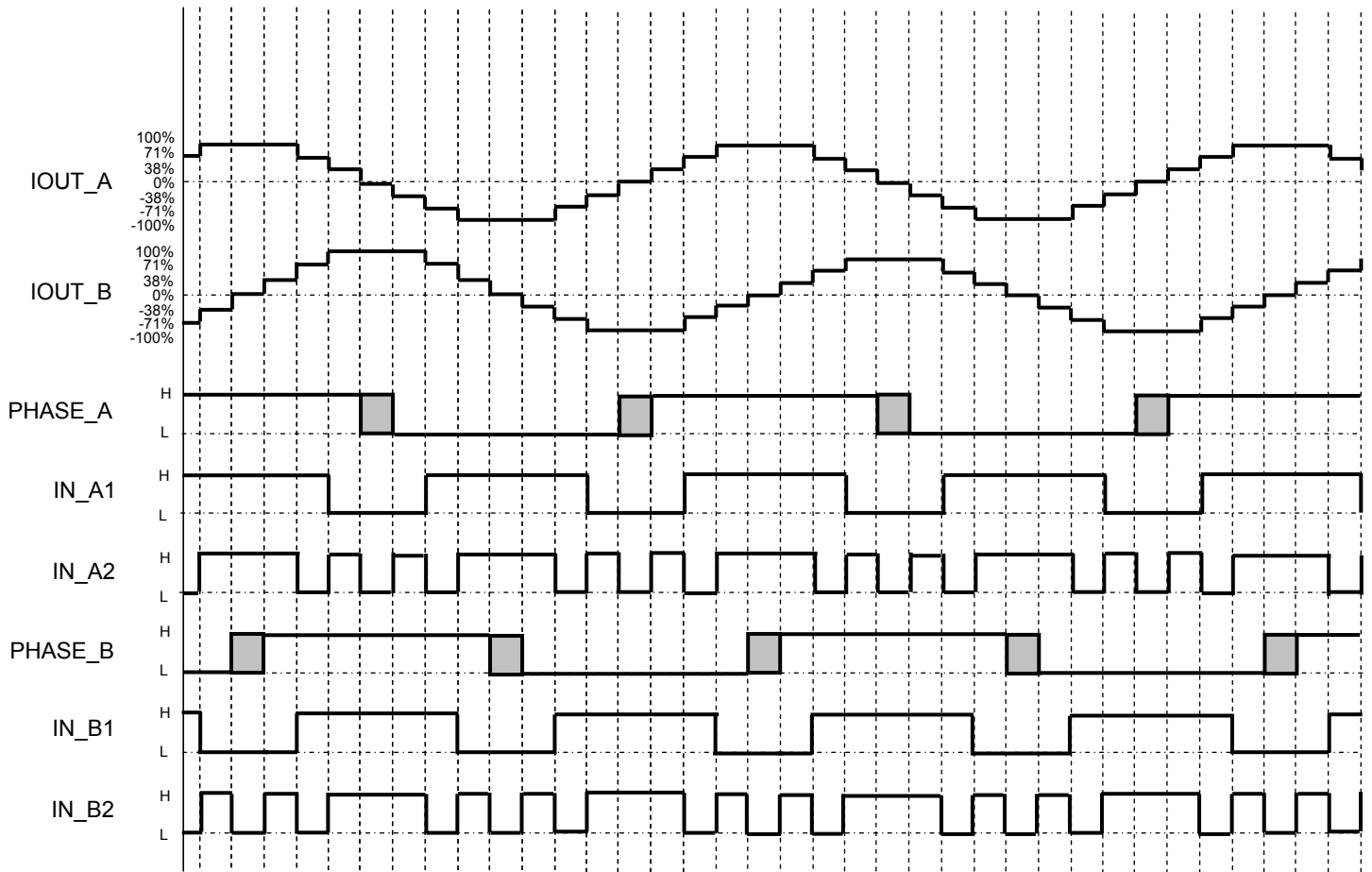

Timing charts may be simplified for explanatory purpose.

**Operation Description**

**IFSEL="L" (Clock input control)**

**CLK function**

Each up-edge of the CLK signal shifts the motor's electrical angle per step.

CLK	Function
↑	Shifts the electrical angle per step.
↓	- (State of the electrical angle does not change.)

**ENABLE function**

The ENABLE pin controls the ON and OFF of the corresponding output stage. Normal constant current control starts by turning on the motor operation. MOSFET is turned off and the output state becomes high impedance by turning off the motor operation.

ENABLE	Function
H	Output MOSFET: ON (Normal operation)
L	Output MOSFET: OFF (Operation OFF, High impedance)

**CW/CCW function**

The CW/CCW pin controls the rotation direction of the motor.

CW/CCW	Function
H	Forward rotation (CW)
L	Reverse rotation (CCW)

**Function of DMODE1 and DMODE2**

The DMODE pins switch the step resolution. The operation moves to the standby mode by setting DMODE1 and DMODE2 pins "L". The operation can resume from the forced off mode, which is configured by the thermal shutdown detection (TSD) and the over current detection (ISD), by setting standby mode once and then setting the normal operation mode again.

DMODE1	DMODE2	Function
L	L	Standby mode (Internal oscillation circuit (OSCM) and output MOSFET: OFF)
L	H	Normal operation mode: Full-step resolution
H	L	Normal operation mode: Half-step resolution
H	H	Normal operation mode: Quarter-step resolution

Setting of DMODE1 and DMODE2 is recommended to change after configuring RESET "L" in the initial state (MO = "L").

**RESET function**

The RESET pin initializes the internal electrical angles.

RESET	Function
H	Set the electrical angle to the initial state
L	Normal operation mode

The current of each channel (while RESET is applied) is shown in the table below.

Step resolution setting	Ach current setting	Bch current setting	Default electrical angle
Full step	100%	100%	45°
Half step	100%	100%	45°
Quarter step	71%	71%	45°

**MO function**

The MO pin confirms the internal electrical angles.

MO	Function
H (Pull-up)	Electrical angle: except initial value
L	Electrical angle: initial value

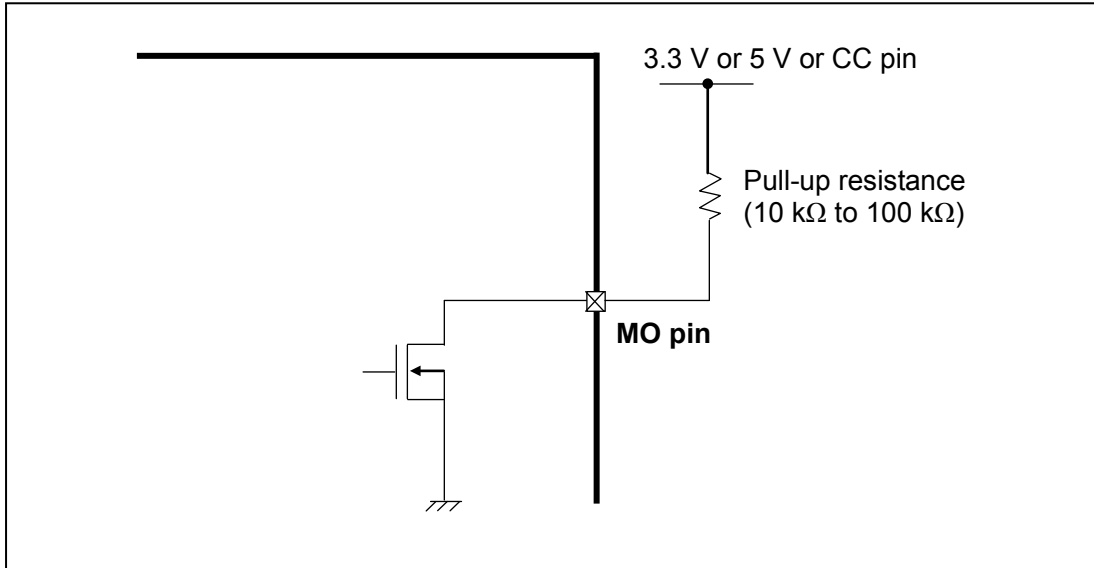

The equivalent circuit diagrams may be simplified or some parts of them may be omitted for explanatory purposes.

**CC pin (Internal regulator monitor pin)**

CC pin is a connect pin of the coupling capacitor for the internal regulator. Please connect the capacitor of 0.1 $\mu$ F or more as close to the CC pin as possible.

CC pin can be applied as a power supply for the connection, where the pull-up resistor of MO pin is connected. In case of applying CC pin as a 5 V-power supply, the usage current (external load current) is recommended to be 5.0 mA or less. And the current limiter is built in to limit the current when the motor drive output is short to the ground.

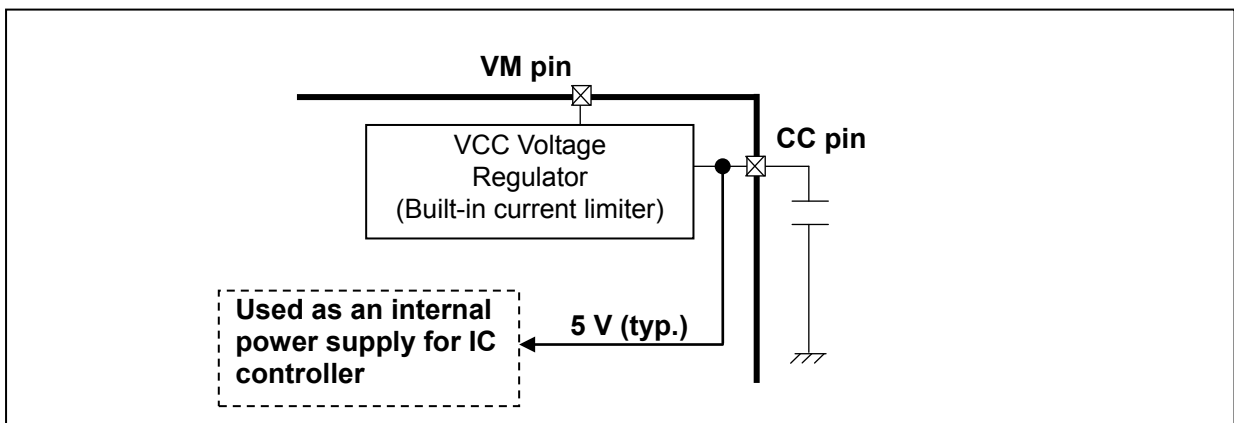

**Sequence in each Drive Mode: IFSEL="L" (Clock input control)**

**Full-step resolution**

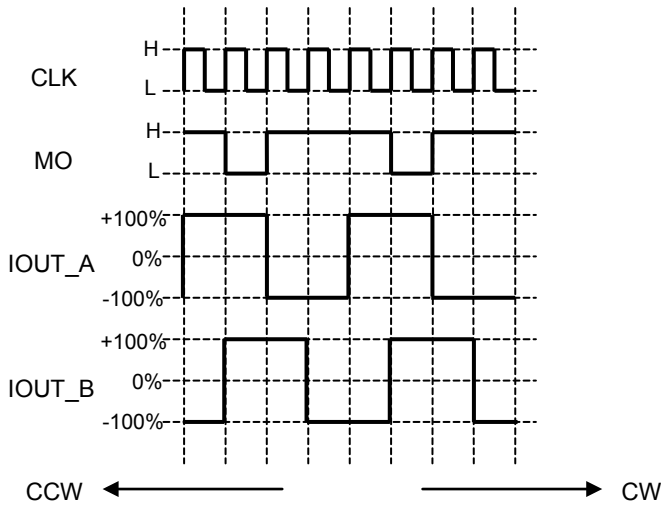

Waveform of MO output: State of pull-up.  
 Timing charts may be simplified for explanatory purpose.

**Half-step resolution**

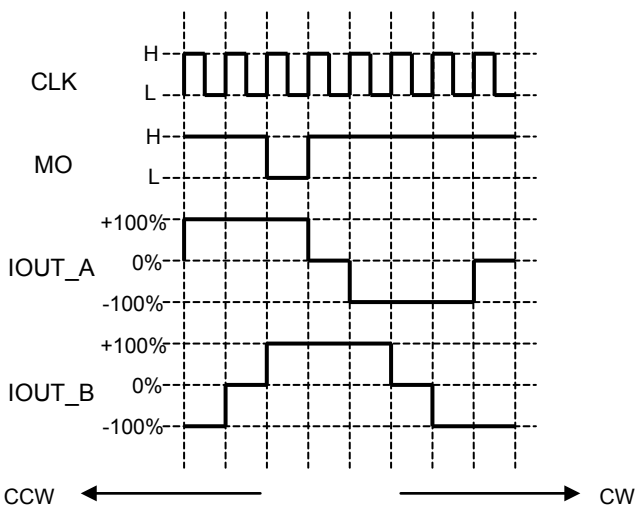

Waveform of MO output: State of pull-up.  
 Timing charts may be simplified for explanatory purpose.

Quarter-step resolution

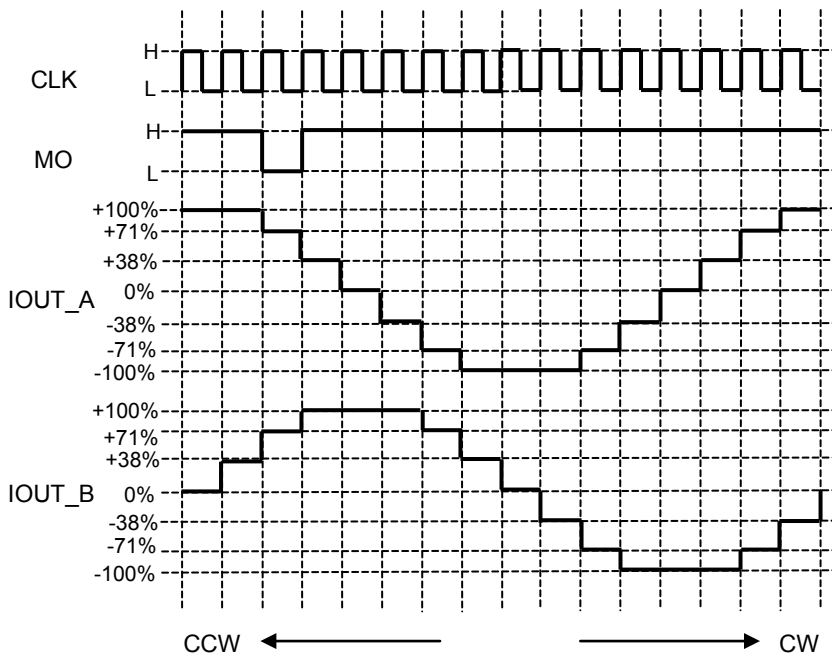

Waveform of MO output: State of pull-up.  
Timing charts may be simplified for explanatory purpose.

**Detection Function**

Built-in below detection functions.

Detection	Target	Detection level	Protection method	Resume method from detection state
Thermal shutdown (TSD)	Chip temperature	160°C(typ.) or more Dead band time of 5.0 μs (typ.)	All outputs are OFF forcedly 80 ms (typ.) after the abnormality is detected.	The function has a latch to maintain the operation state before detection.
Over current detection (ISD)	Output current	4.75 A(typ.) or more Dead band time of 1.25 μs (typ.)	All outputs are OFF forcedly 80 ms (typ.) after the abnormality is detected.	The operation resumes by below process. · Power supply is reapplied. or · Standby mode is set once and normal mode is set again.
Under voltage lockout (UVLO)	Voltage of VM	7.5 V(typ.) or less Dead band time of 1.41 μs (typ.)	All outputs are OFF forcedly. Internal circuits are reset.	VM is raised to 8.0 V (typ.) or more.
	Voltage of CC	4.0 V(typ.) or less Dead band time of 1.41 μs (typ.)		VM is raised to 4.2 V (typ.) or more.

**Thermal shutdown detection (Latch type: Operation state before detection is maintained.)**

This function turns off the IC operation temporarily when the over heat of the device is detected. It has a dead band time to avoid error detection occurred by the external noise. All DMOS are turned off after the energy of the motor coil is discharged. Therefore, outputs are turned off after the current is regenerated by the synchronous rectification control. When over heat is detected, all channels are turned off.

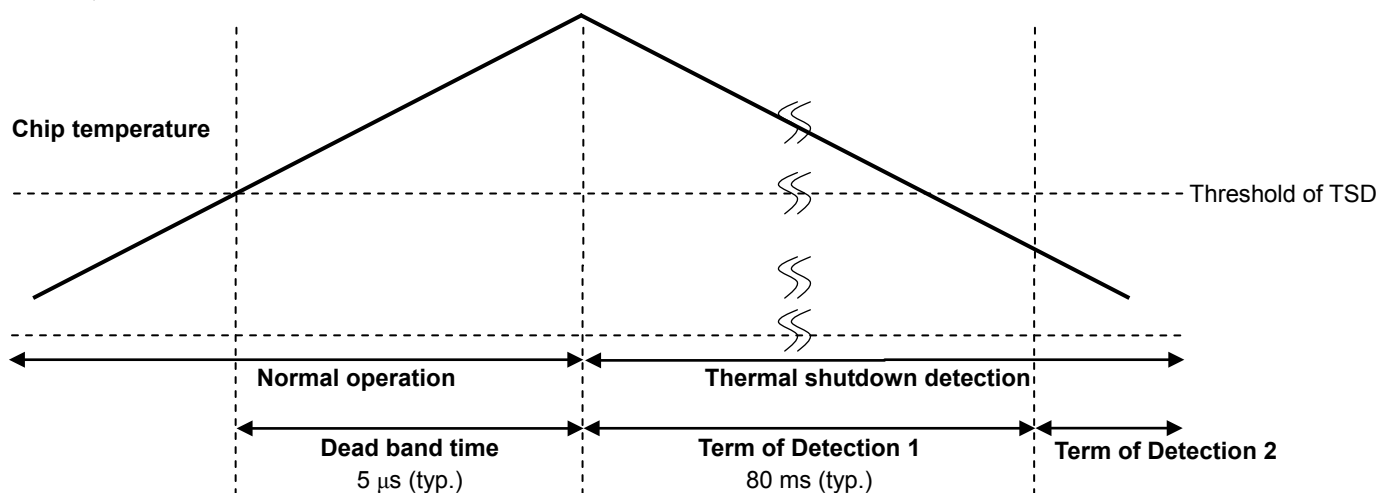

Timing charts may be simplified for explanatory purposes. The value in the timing chart is the reference value.

- When over heat is detected

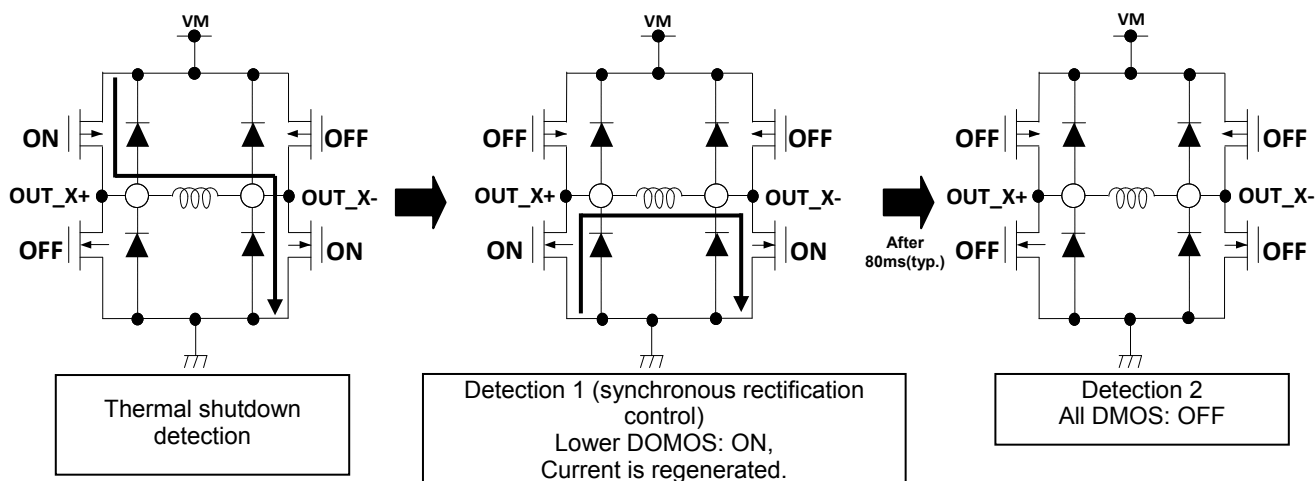

**Over current detection (Latch type: Operation state before detection is maintained.)**

This function turns off the IC operation temporarily when the short-circuiting between outputs and the short-circuiting to the power supply or ground occur. It has a dead band time to avoid error detection occurred by the spike current which generates in switching and the external noise. All DMOS are turned off after the energy of the motor coil is discharged. Therefore, outputs are turned off after the current is regenerated by the synchronous rectification control. When over current is detected, not only the corresponding channels but both channels are turned off.

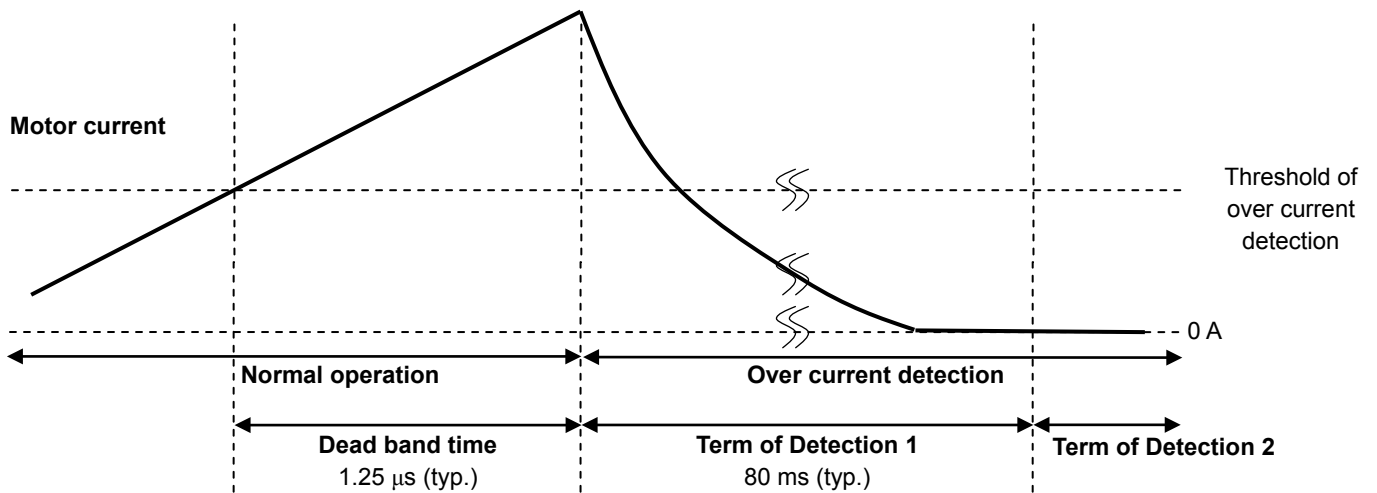

Timing charts may be simplified for explanatory purposes. The value in the timing chart is the reference value.

- When over current is detected in the lower DMOS of H-bridge by the short-circuiting to the power supply

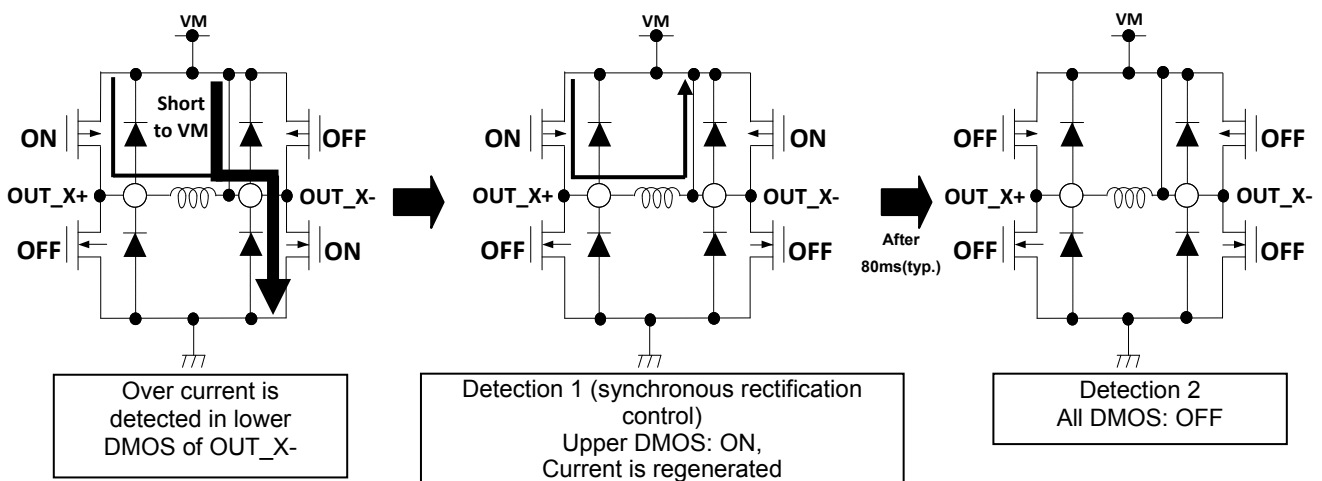

- When over current is detected in the upper DMOS of H-bridge by the short-circuiting to the ground

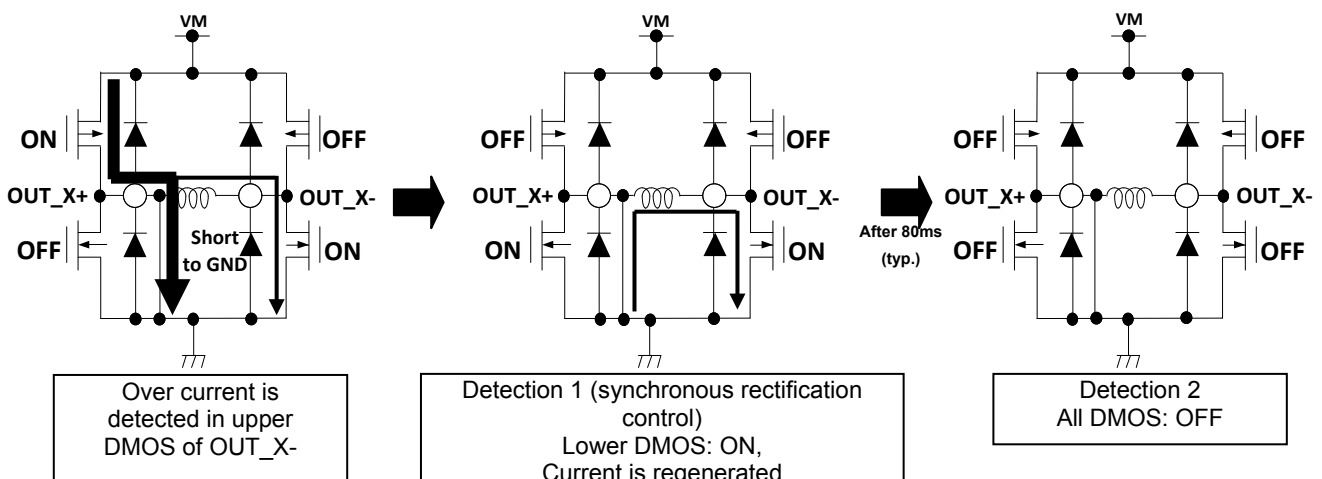



**Absolute Maximum Ratings (T<sub>a</sub> = 25°C)**

Characteristics	Symbol	Rating	Unit
Motor power supply	V <sub>M</sub>	40	V
Motor output voltage	V <sub>OUT</sub>	40	V
Motor output current (Note1)	I <sub>OUT</sub>	3.0	A/phase
Monitor voltage for internal regulator	V <sub>CC</sub>	6.0	V
Logic input voltage	V <sub>IN</sub>	6.0	V
V <sub>ref</sub> reference voltage	V <sub>ref</sub>	6.0	V
Monitor voltage for electrical angle	V <sub>MO</sub>	6.0	V
Power dissipation (Note2)	P <sub>D</sub>	4.3	W
Operating temperature	T <sub>opr</sub>	-20 to 85	°C
Storage temperature	T <sub>stg</sub>	-55 to 150	°C
Junction temperature	T <sub>j(MAX)</sub>	150	°C

Note1: The maximum current value in normal operation should be kept 2.8 A or less per phase after calculating heat generation. The maximum output current may be further limited in view of the thermal considerations, depending on the ambient temperature and board conditions.

Note2: Based on JEDEC standard 4-layer PCB (T<sub>a</sub> = 25°C)  
When T<sub>a</sub> exceeds 25°C, derating with 34.4mW/°C is necessary.

- T<sub>a</sub> : Ambient temperature of the IC
- T<sub>opr</sub> : Ambient temperature while the IC is active.
- T<sub>j</sub> : Junction temperature while the IC is active. The maximum junction temperature is limited by the thermal shutdown circuit (TSD).

It is advisable to keep the maximum current below a certain level so that the maximum junction temperature, T<sub>j</sub> (MAX), will not exceed 120°C.

**Absolute maximum ratings**

The absolute maximum ratings of a semiconductor device are a set of ratings that must not be exceeded, even for a moment. Do not exceed any of these ratings.

Exceeding the rating (s) may cause device breakdown, damage or deterioration, and may result in injury by explosion or combustion. The value of even one parameter of the absolute maximum ratings should not be exceeded under any circumstances. The TB67S508FTG does not have overvoltage detection circuit. Therefore, the device is damaged if a voltage exceeding its rated maximum is applied.

All voltage ratings, including supply voltages, must always be followed. The other notes and considerations described later should also be referred to.

**Operation Ranges (T<sub>a</sub> = -20 to 85°C)**

Characteristics	Symbol	Min	Typ.	Max	Unit	Remarks
Motor power supply (Note1)	V <sub>M</sub>	10.0	24.0	35.0	V	—
Motor output current	I <sub>OUT</sub>	—	—	2.8	A	Per phase (Note2)
Logic input voltage	V <sub>IN(H)</sub>	2.0	—	5.5	V	Logic input High Level
	V <sub>IN(L)</sub>	-0.5	—	0.8	V	Logic input Low Level
Chopping frequency	f <sub>CHOP</sub>	40	70	150	kHz	—
PHASE frequency	f <sub>PHASE</sub>	—	—	400	kHz	—
Clock frequency	f <sub>CLK</sub>	—	—	100	kHz	—
V <sub>ref</sub> reference voltage	V <sub>REF</sub>	0	—	3.6	V	—

Note1: Slew rate in the range of 0 V to 10 V: 1 ms or more is recommended.

Note2: The actual maximum current may be limited by the operating environment (operating conditions such as exciting mode and operating time, or by the surrounding temperature or board heat dissipation). Determine a realistic maximum current by calculating the heat generated under the operating environment.

Electrical Characteristics 1 ( $T_a = 25^\circ\text{C}$ ,  $V_M = 24\text{ V}$ , unless specified otherwise)

Characteristics		Symbol	Test condition	Min	Typ.	Max	Unit
Logic input voltage	High	$V_{IN(H)}$	Logic input pin (Note)	2.0	—	5.5	V
	Low	$V_{IN(L)}$	Logic input pin (Note)	-0.5	—	0.8	V
Logic input hysteresis voltage		$V_{IN(HYS)}$	Logic input pin (Note)	100	200	300	mV
Logic input current	High	$I_{IN(H)}$	Logic input voltage: 5 V	35	50	75	$\mu\text{A}$
	Low	$I_{IN(L)}$	Logic input voltage: 0 V	—	—	1	$\mu\text{A}$
MO output pin voltage		$V_{OL(MO)}$	IOL=5 mA, Output: Low	—	0.2	0.5	V
Power consumption		$I_{M1}$	Output pin: Open, Standby mode	—	2	3	mA
		$I_{M2}$	Output pin: Open, Operating mode	—	4	6	mA
		$I_{M3}$	Output pin: Open (Full-step resolution) Chopping frequency: 40 kHz	—	7	9	mA
Output leakage current	High-side	$I_{OH}$	$V_M = 40\text{ V}$ , $V_{OUT} = 0\text{ V}$	—	—	1	$\mu\text{A}$
	Low-side	$I_{OL}$	$V_M = V_{OUT} = 40\text{ V}$	1	—	—	$\mu\text{A}$
Motor current channel differential		$\Delta I_{OUT1}$	Current differential between Ch $I_{OUT} = 1.0\text{ A}$	-5	0	5	%
Motor current setting accuracy		$\Delta I_{OUT2}$	$I_{OUT} = 1.0\text{ A}$	-5	0	5	%
Motor output ON-resistance (High-side + Low-side)		$R_{ON(D-S)}$	$T_j = 25^\circ\text{C}$ $I_{OUT} = 2.0\text{ A}$	—	0.45	0.65	$\Omega$

Note:  $V_{IN(H)}$  is defined as the  $V_{IN}$  voltage that changes the output voltage by being applied to the test pin and raising this voltage from 0V gradually.  $V_{IN(L)}$  is defined as the  $V_{IN}$  voltage that changes the output voltage by being applied to the test pin and lowering this voltage gradually. The difference between  $V_{IN(H)}$  and  $V_{IN(L)}$  is defined as  $V_{IN(HYS)}$ .

**Electrical Characteristics 2 ( $T_a = 25^\circ\text{C}$ ,  $V_M = 24\text{ V}$ , unless specified otherwise)**

Characteristics	Symbol	Test condition	Min	Typ.	Max	Unit
$V_{ref}$ input current	$I_{REF}$	$V_{ref} = 3.6\text{ V}$	—	0	1	$\mu\text{A}$
$V_{ref}$ decay ratio	$V_{REF(GAIN)}$	$V_{ref} = 2.0\text{ V}$	0.791	0.833	0.875	—
TSD threshold	$T_{JTSD}$	—	145	160	175	$^\circ\text{C}$
VM power ON reset voltage	$V_{MPOR(H)}$	Release POR	7.5	8.0	8.5	V
	$V_{MPOR(L)}$	Detect POR	7.0	7.5	8.0	
Over-current detection threshold	$I_{SD}$	—	3.5	4.75	6.0	A
Power supply voltage for operating internal circuit	$V_{CC}$	$I_{CC} = 5.0\text{ mA}$ (External load)	4.75	5.00	5.25	V

**Back-EMF**

While a motor is rotating, there is a timing at which power is fed back to the power supply. At that timing, the motor current recirculates back to the power supply due to the effect of the motor back-EMF.

If the power supply does not have enough sink capability, the power supply and output pins of the device might rise above the rated voltages. The magnitude of the motor back-EMF varies with usage conditions and motor characteristics. It must be fully verified that there is no risk that the TB67S508FTG or other components will be damaged or fail due to the motor back-EMF.

**Cautions on Overcurrent Shutdown (ISD) and Thermal Shutdown (TSD)**

The ISD and TSD circuits are only intended to provide temporary protection against irregular conditions such as an output short-circuit; they do not necessarily guarantee the complete IC safety.

If the device is used beyond the specified operating ranges, these circuits may not operate properly: then the device may be damaged due to an output short-circuit.

The ISD circuit is only intended to provide a temporary protection against an output short-circuit. If such a condition persists for a long time, the device may be damaged due to overstress. Overcurrent conditions must be removed immediately by external hardware.

**IC Mounting**

Do not insert devices incorrectly or in the wrong orientation. Otherwise, it may cause breakdown, damage and/or deterioration of the device.

AC Electrical Characteristics ( $T_a = 25^\circ\text{C}$ ,  $V_M = 24\text{V}$ )

Characteristics	Symbol	Test condition	Min	Typ.	Max	Unit
Minimum phase pulse width	$t_{\text{PHASE(H)}}$	—	600	—	—	ns
	$t_{\text{PHASE(L)}}$	—	600	—	—	ns
Minimum clock pulse width	$t_{\text{CLK(H)}}$	—	300	—	—	ns
	$t_{\text{CLK(L)}}$	—	250	—	—	ns
Output transistor Switching characteristics	$t_r$	—	40	70	100	ns
	$t_f$	—	50	80	110	ns
	$t_{\text{pLH(CLK)}}$	—	—	400	—	ns
	$t_{\text{pHL(CLK)}}$	—	—	400	—	ns
	$t_{\text{pLH(PHASE)}}$	—	—	400	—	ns
	$t_{\text{pHL(PHASE)}}$	—	—	400	—	ns
Oscillator reference frequency	$f_{\text{OSCM1}}$	$R_{\text{OSC}}=10\text{ k}\Omega$	860	1100	1340	kHz
	$f_{\text{OSCM2}}$	OSCM: Open or connecting to GND	866	1080	1293	
Chopping frequency	$f_{\text{CHOP}}$	$f_{\text{OSCM}} = 1100\text{ kHz}$	—	68.8	—	kHz

**AC Electrical Characteristics Timing chart**  
**IFSEL="H" (Phase input control)**

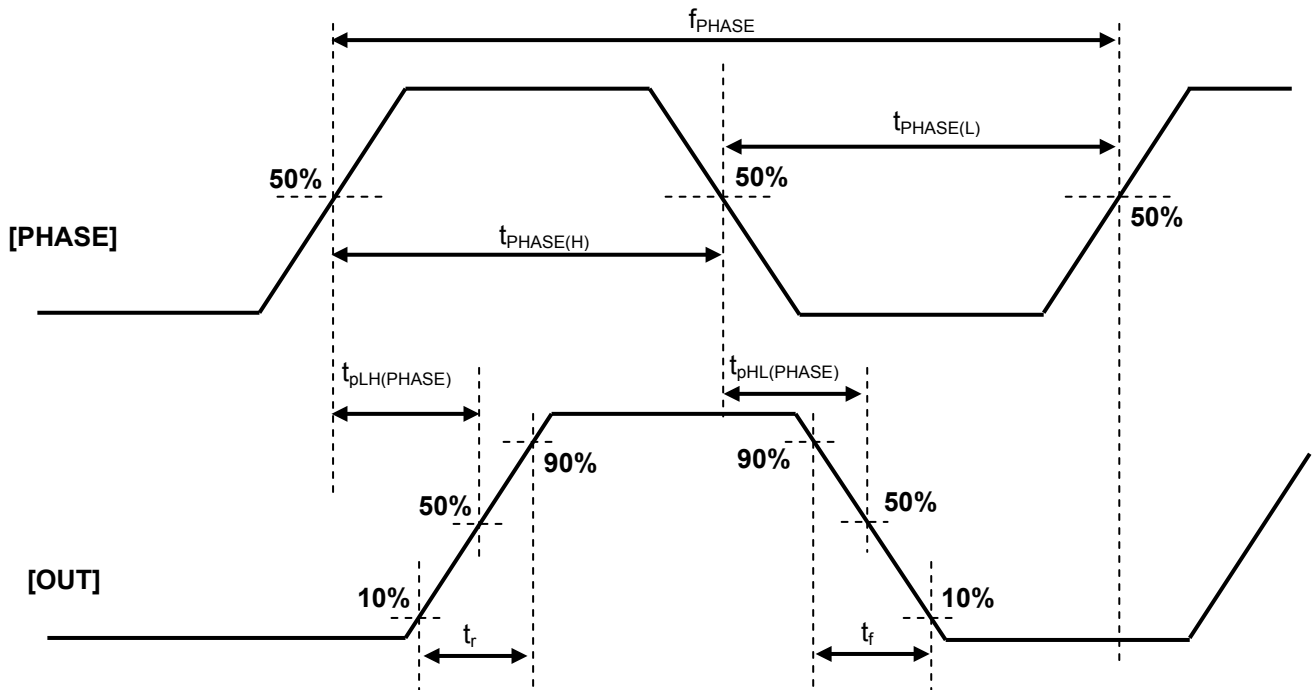

Timing charts may be simplified for explanatory purpose.

**IFSEL="L" (clock input control)**

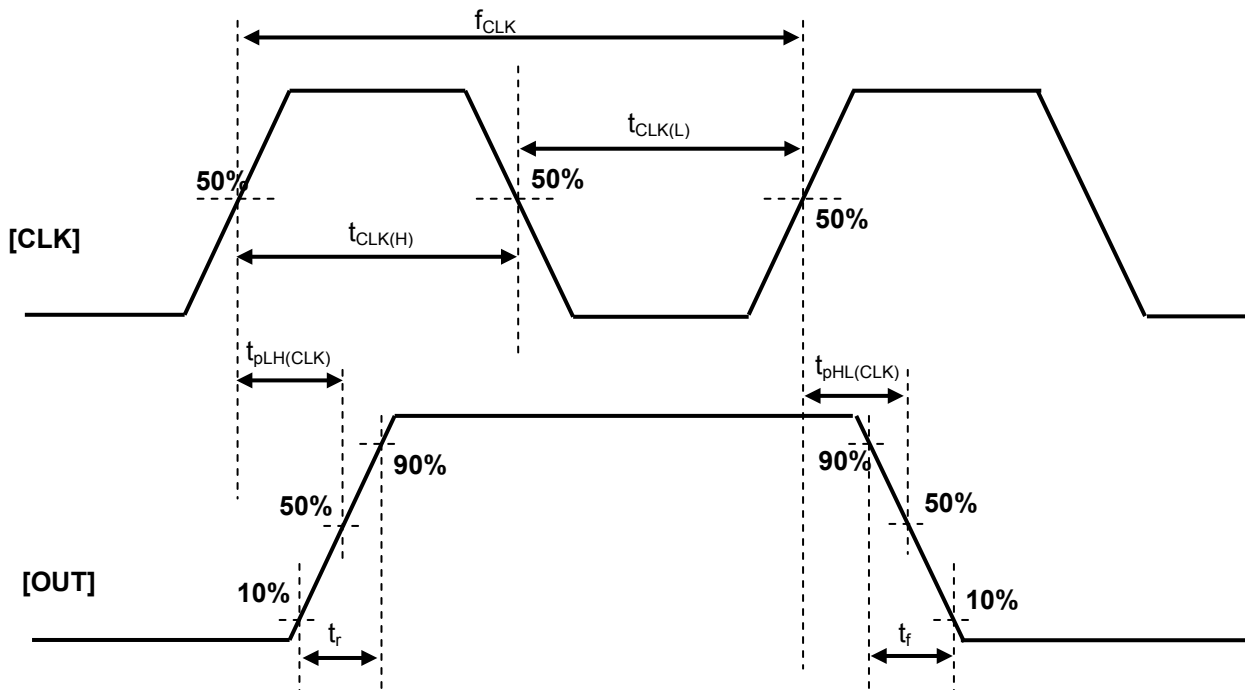

Timing charts may be simplified for explanatory purpose.

**Constant PWM Control**

**ADMD (Advanced Dynamic Mixed Decay) Control**

ADMD control adjusts the regeneration amount of the power supply by monitoring the charge current, which flows from the power supply to the motor, and the regeneration current, which flows from the motor to the power supply. Then, the motor is controlled efficiently.

Sequence of ADMD control is shown in the below timing chart.

Sequence: Charge mode → NF detection → Fast mode → ADMDth detection → Slow mode →  $f_{CHOP1}$  cycle → Charge mode

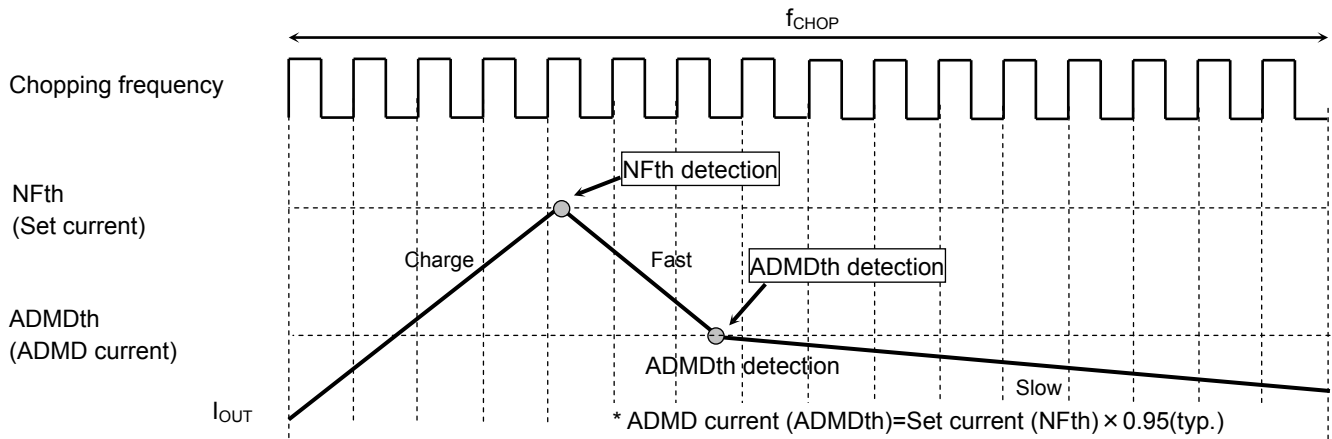

Timing charts may be simplified for explanatory purposes. The value in the timing chart is the reference value.

Each filter is attached in order to avoid current-detection error caused by the external noise, etc. (Shown in below figure.) L value of the motor to be used is small, and when the current value reaches ADMDth (ADMD current value) within the ADMDtblank period, it changes to Slow operation after progress during the ADMDtblank. In this case, the ADMD current value (ADMDth) becomes smaller than "setting current value (NFth) x 0.95 (typ.)".

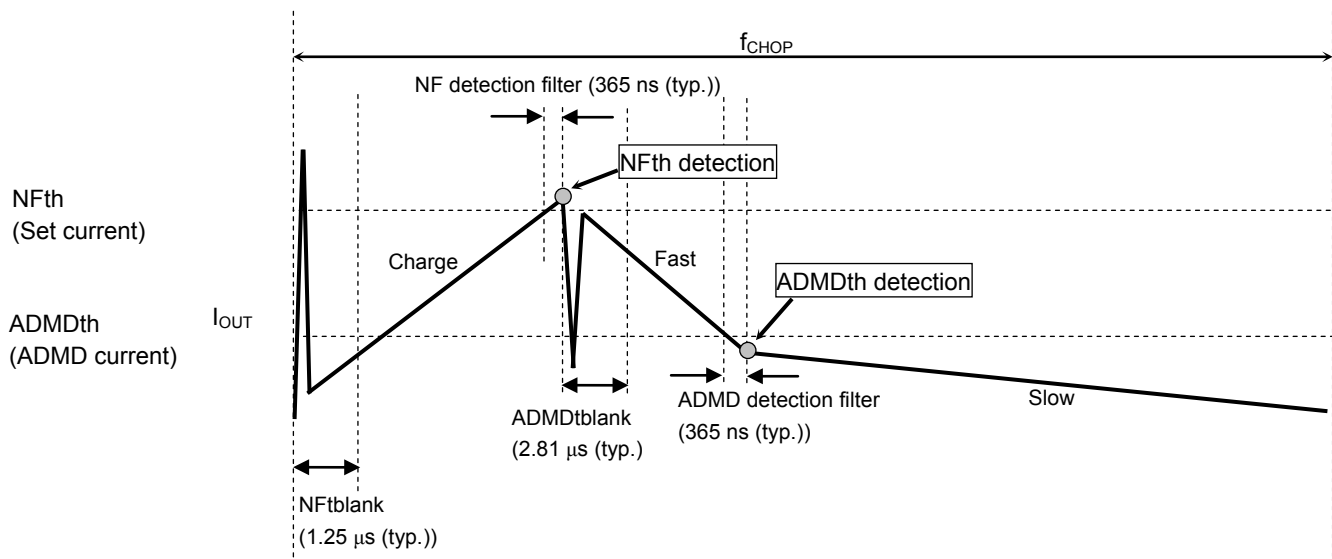

Timing charts may be simplified for explanatory purposes. The value in the timing chart is the reference value.

**ADMD Current Waveform**

· When the next current step (NFth) is higher:

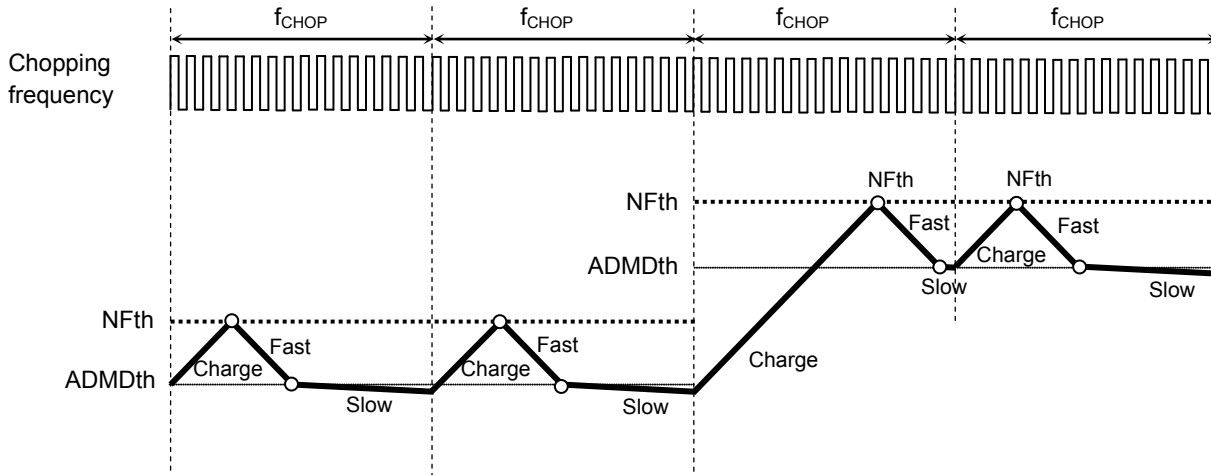

Timing charts may be simplified for explanatory purposes.

· When Charge term  $\geq 1$  fchop cycle:

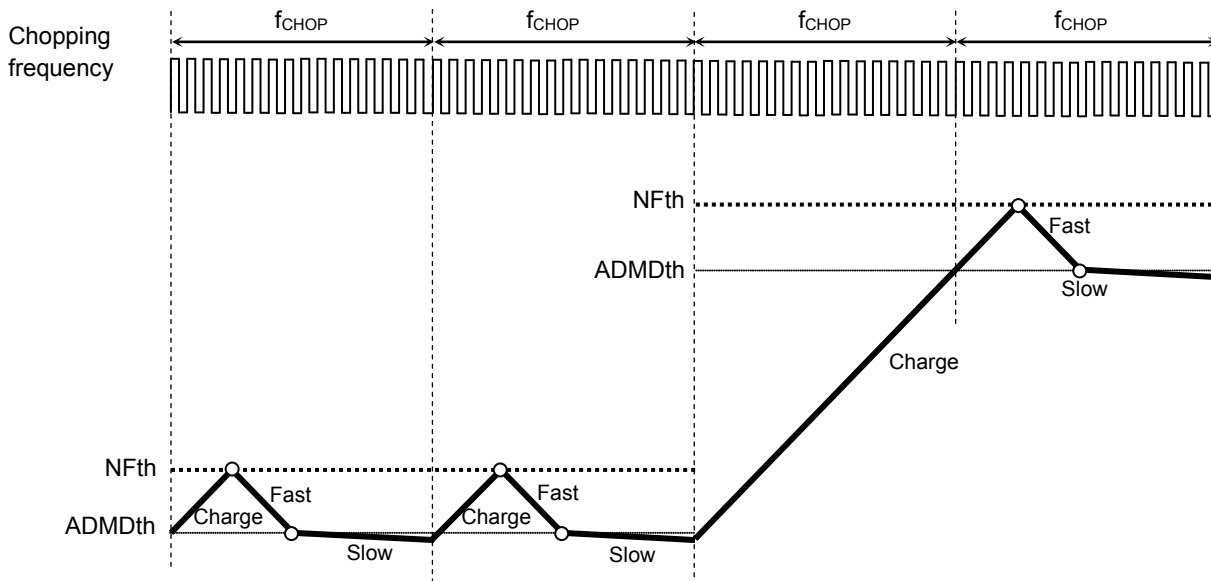

Timing charts may be simplified for explanatory purposes.

When the motor current value does not reach the threshold (NFth) during 1 cycle of the chopping frequency ( $f_{CHOP}$ ), the Charge mode continues in the next chopping cycle ( $f_{CHOP}$ ). The operation mode moves to the Fast mode after the motor current value reaches the threshold (NFth).

· When the next current step (NFth) is lower:

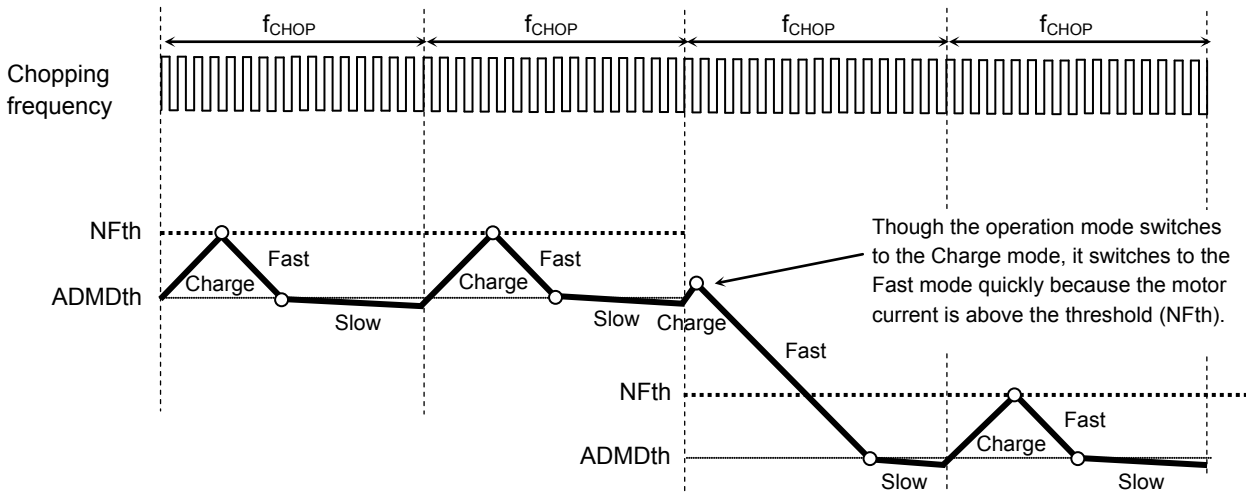

Timing charts may be simplified for explanatory purposes.

· When the Fast mode continues for the term that exceeds 1 fchop cycle (the motor current does not reach the ADMD threshold during 1 fchop cycle)

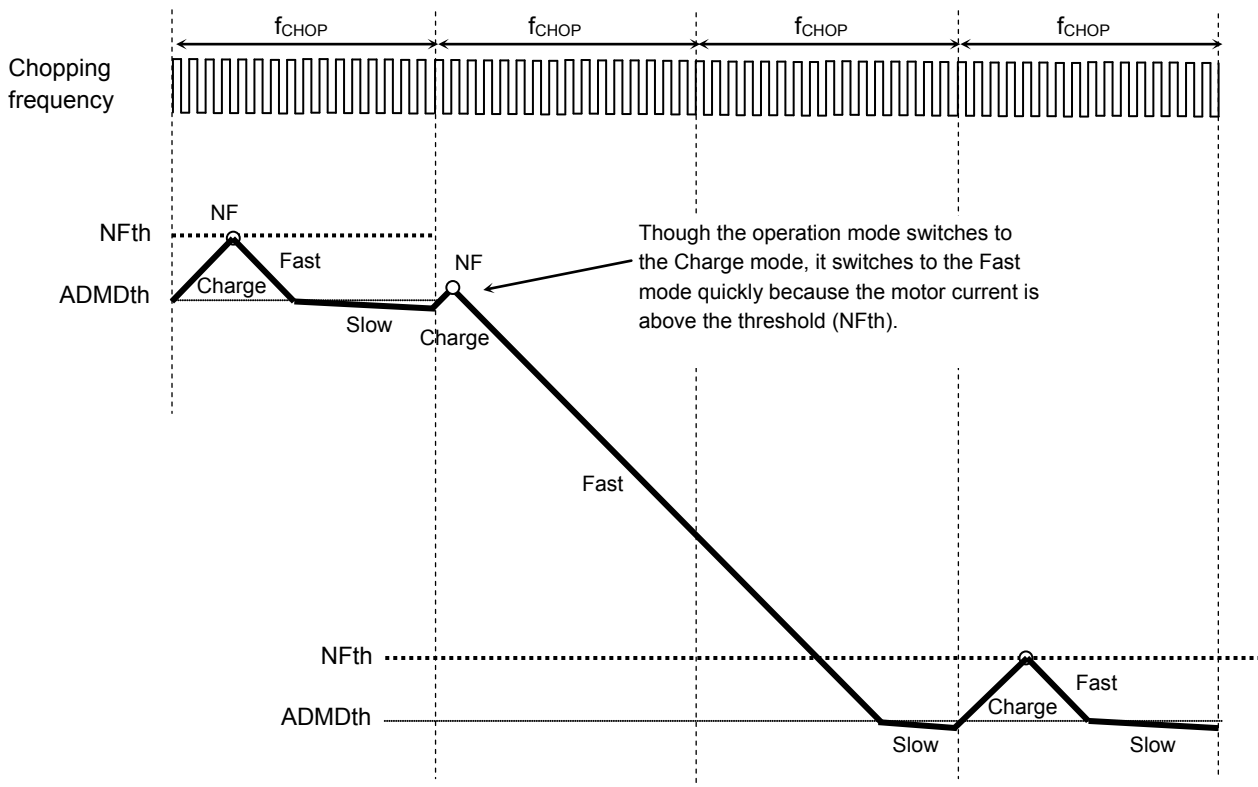

Timing charts may be simplified for explanatory purposes.

When the motor current value does not reach the threshold (ADMDth) during 1 cycle of the chopping frequency ( $f_{CHOP}$ ), the Fast mode continues in the next chopping cycle ( $f_{CHOP}$ ). The operation mode moves to the Slow mode after the motor current value reaches the threshold (ADMDth).



**Output Transistor Function Mode (Advanced Dynamic Mixed Decay)**

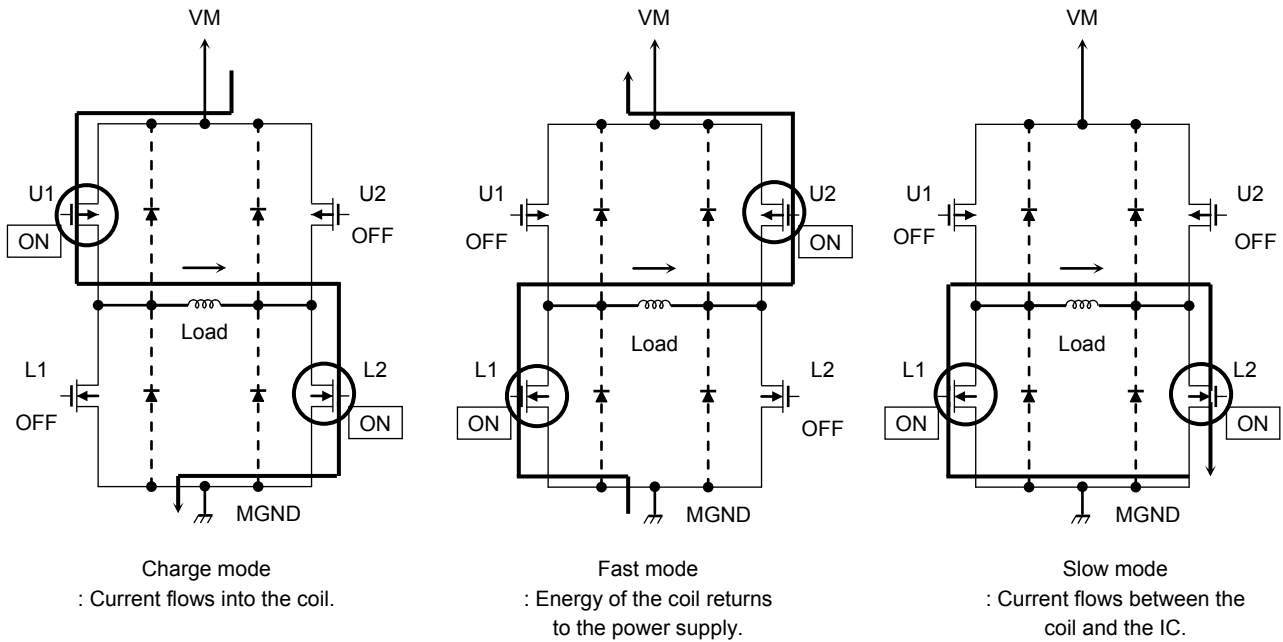

\* When output switches, cross-conduction protection time is provided in the IC to avoid penetrating current.

**Output transistor function**

Mode	U1	U2	L1	L2
CHARGE	ON	OFF	OFF	ON
FAST	OFF	ON	ON	OFF
SLOW	OFF	OFF	ON	ON

Note: This table shows an example of when the current flows as indicated by the arrows in the above figures.

If the current flows in the opposite direction, refer to the following table.

Mode	U1	U2	L1	L2
CHARGE	OFF	ON	ON	OFF
FAST	ON	OFF	OFF	ON
SLOW	OFF	OFF	ON	ON

This IC controls the motor current to be constant by 3 modes listed above.

The equivalent circuit diagrams may be simplified or some parts of them may be omitted for explanatory purposes.

## Setting Current Value ( $I_{OUT}$ )

The setting current value in the PWM constant-current control mode is determined by the reference voltage ( $V_{REF}$ ) as follows;

The current value to be set can be calculated by the following formula.

$$I_{OUT} = V_{REF} \times 0.833$$

Ex.) When  $V_{REF} = 2.0$  V,  $I_{OUT} = 1.67$  A

## Chopping Frequency ( $f_{CHOP}$ )

Chopping frequency of the constant current control can be configured by the resistor ( $R_{OSC}$ ) connected to OSCM pin. The IC can operate by the fixed chopping frequency without attaching the external part to OSCM pin.

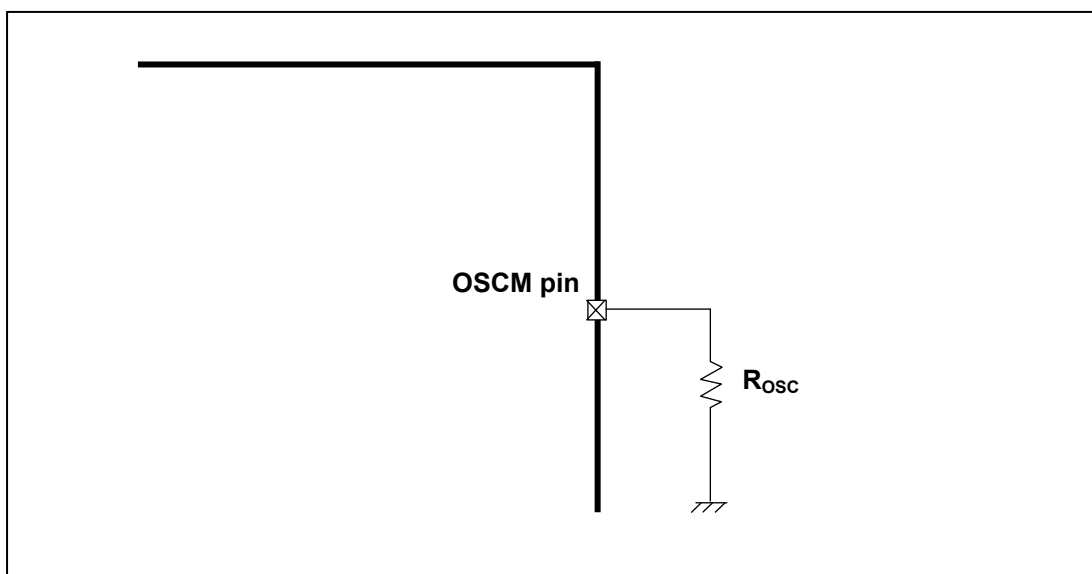

The equivalent circuit diagrams may be simplified or some parts of them may be omitted for explanatory purposes.

Chopping frequency ( $f_{CHOP}$ ) is calculated from below formula.

Generally, a standard frequency is approximately 70 kHz. A setup in the range of 40 to 100 kHz is recommended.

$$f_{CHOP} = f_{OSCM} / 16$$

$$f_{OSCM} = 1 / (90.9 \times 10^{-12} \times R_{OSC})$$

Ex.): When  $R_{OSC} = 10$  k $\Omega$ ,  $f_{OSCM} = 1.1$  MHz (typ.),  $f_{CHOP} = 68.8$  kHz (typ.)

Under the condition that OSCM pin is open or connected to the GND, the IC operates by the frequency generated automatically ( $f_{OSCM2} = 1.080$  MHz (typ.),  $f_{CHOP} = 67.5$  kHz (typ.)).

**Power consumption of the IC**

Power of the IC is consumed by the transistor of the output block and that of the logic block mainly.

**1. Power consumption of the power transistor**

Power of the output block is consumed by the upper and lower MOSFET of the H-Bridge.

Power consumption of the upper or lower transistor of the H-Bridge is calculated from below formula.

$$P \text{ (out)} = I_{out} \text{ (A)} \times V_{DS} \text{ (V)} = I_{out} \text{ (A)}^2 \times R_{on} \text{ (\Omega)} \dots\dots\dots(1)$$

When the current waveform of the motor output corresponds to the ideal square waveform in the full-step resolution, average power of output block can be provided as follows

When  $R_{on} = 0.45 \Omega$ ,  $I_{out} \text{ (peak: Max)} = 1.0 \text{ A}$ , and  $V_M = 24 \text{ V}$ ,

$$P \text{ (out)} = 2 \text{ (Tr)} \times 1.0 \text{ (A)}^2 \times 0.45(\Omega) \dots\dots\dots(2)$$

$$= 0.9(W)$$

**2. Power consumption of logic and IM systems**

Power consumptions of logic and IM systems are calculated by separating the states (operating and stopping).

- $I \text{ (IM3)} = 7 \text{ mA (typ.)}$  : Operating/axis
- $I \text{ (IM2)} = 4 \text{ mA (typ.)}$  : Stopping/axis
- $I \text{ (IM1)} = 2 \text{ mA (typ.)}$  : Standby/axis

Output system is connected to  $V_M$  (24V). (Output system: Current consumed by the circuit connected to  $V_M$  + Current consumed by switching output steps)

Power consumption is calculated as follows;

$$P \text{ (IM3)} = 24 \text{ (V)} \times 0.007 \text{ (A)} \dots\dots\dots(3)$$

$$= 0.17 \text{ (W)}$$

**3. Power consumption**

Total power consumption  $P \text{ (total)}$  is calculated from the results of '1' and '2' above.

$$P = P \text{ (out)} + P \text{ (IM3)} = 1.07(W)$$

Power consumption of 1 axle in standby mode is as follows;

$$P \text{ (Standby mode)} = 24 \text{ (V)} \times 0.002 \text{ (A)} = 0.048 \text{ (W)}$$

About the heat design of the board etc., please evaluate it by the actual board enough, and configure the appropriate margin.

**Example of application circuit**

Phase input control mode

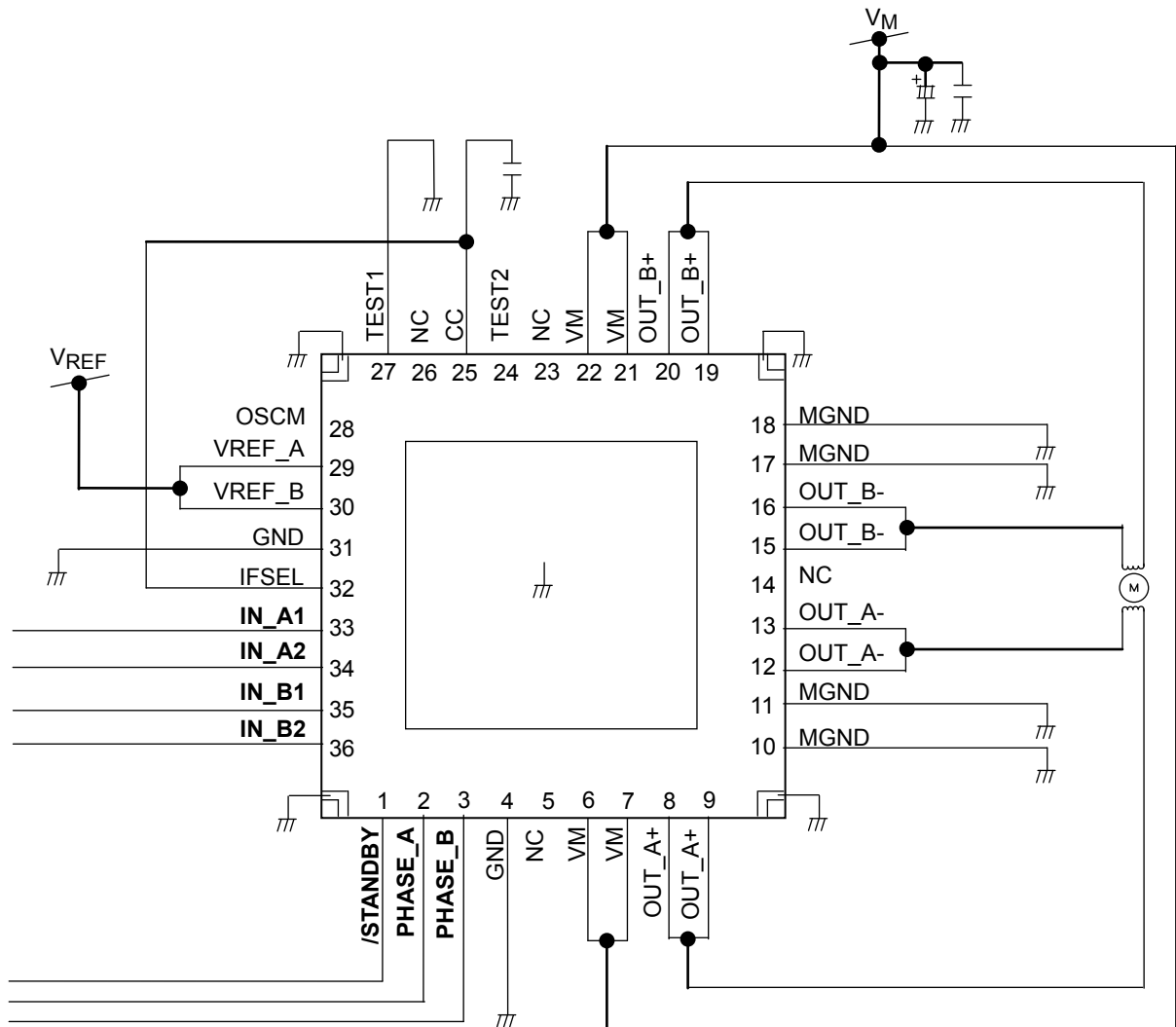

Heat dissipation PAD (4 corners and the center part) on the back of the package is recommended to connect to the GND of the board for improved heat dissipation.

The example of application circuit may be simplified or some parts of them may be omitted for explanatory purposes.

Clock input control mode

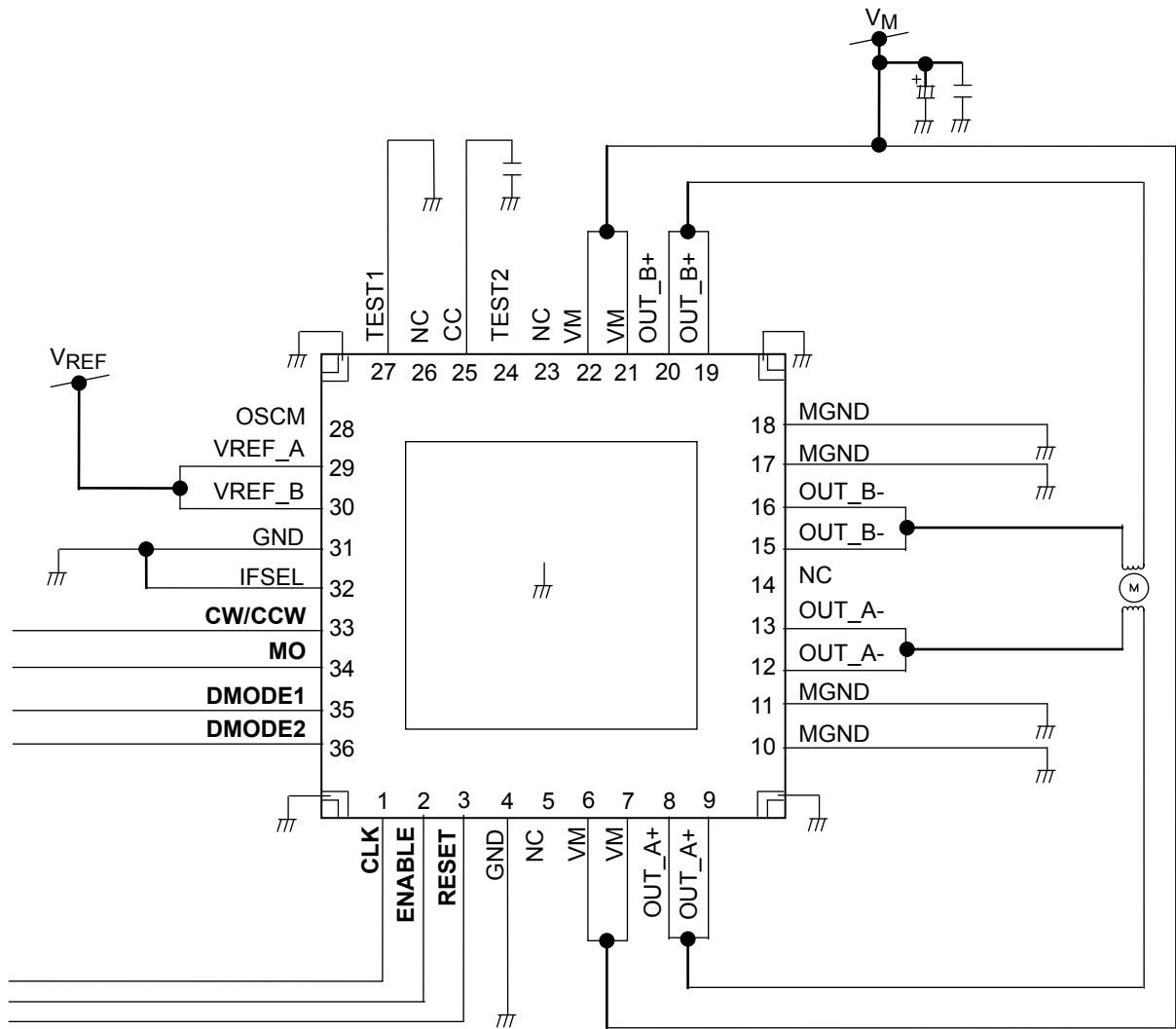

Heat dissipation PAD (4 corners and the center part) on the back of the package is recommended to connect to the GND of the board for improved heat dissipation.

The example of application circuit may be simplified or some parts of them may be omitted for explanatory purposes.

**Package Dimensions**

P-VQFN36-0505-0.50-002

Unit: mm

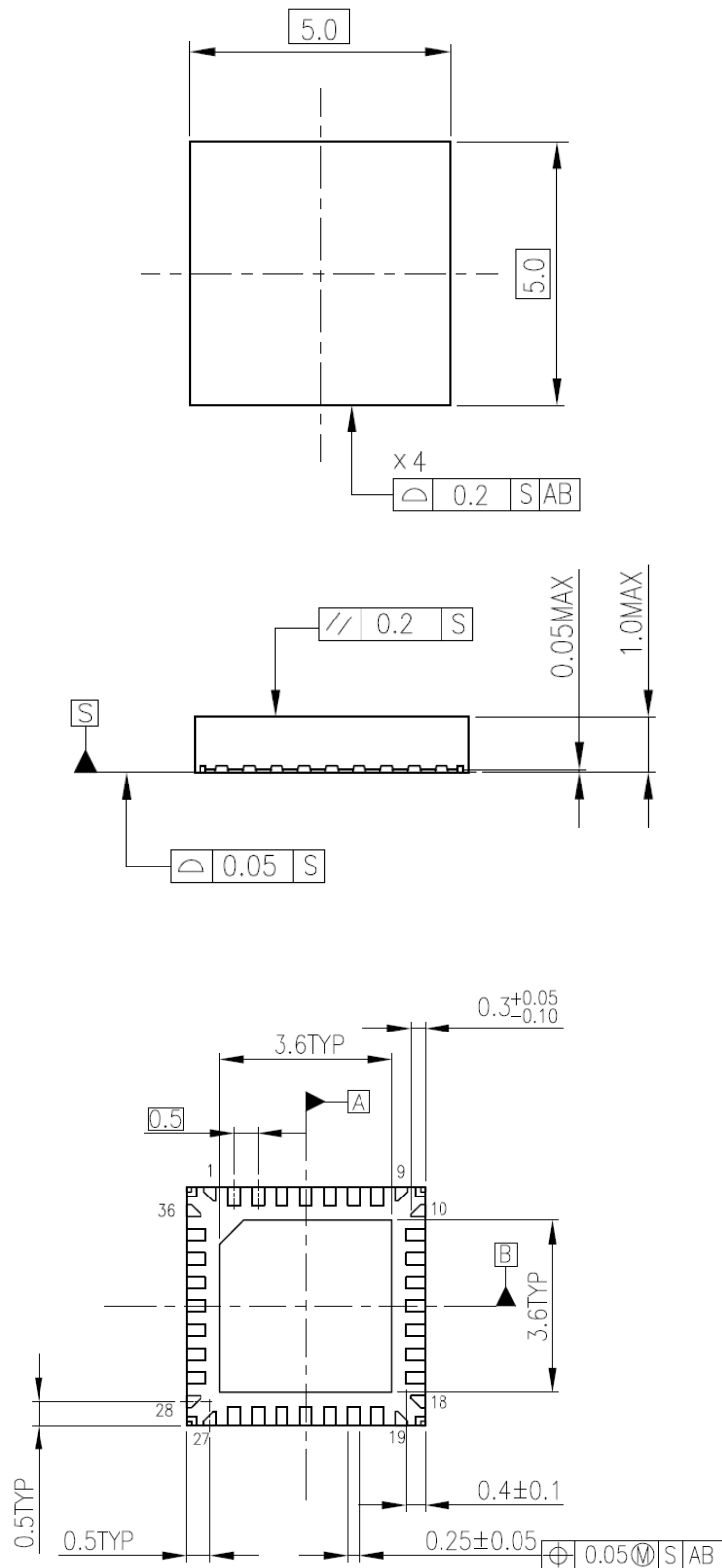

Weight: 0.06 g (typ.)

## Notes on Contents

### Block Diagrams

Some of the functional blocks, circuits, or constants in the block diagram may be omitted or simplified for explanatory purposes.

### Timing Charts

Timing charts may be simplified for explanatory purposes.

### Application Circuits

The application circuits shown in this document are provided for reference purposes only. Thorough evaluation is required, especially at the mass production design stage.

Toshiba does not grant any license to any industrial property rights by providing these examples of application circuits.

## IC Usage Considerations

### Notes on handling of ICs

- [1] The absolute maximum ratings of a semiconductor device are a set of ratings that must not be exceeded, even for a moment. Do not exceed any of these ratings.  
Exceeding the rating(s) may cause the device breakdown, damage or deterioration, and may result injury by explosion or combustion.
- [2] Do not insert devices in the wrong orientation or incorrectly.  
Make sure that the positive and negative terminals of power supplies are connected properly.  
Otherwise, the current or power consumption may exceed the absolute maximum rating, and exceeding the rating(s) may cause the device breakdown, damage or deterioration, and may result injury by explosion or combustion.  
In addition, do not use any device that is applied the current with inserting in the wrong orientation or incorrectly even just one time.
- [3] Use an appropriate power supply fuse to ensure that a large current does not continuously flow in case of over current and/or IC failure. The IC will fully break down when used under conditions that exceed its absolute maximum ratings, when the wiring is routed improperly or when an abnormal pulse noise occurs from the wiring or load, causing a large current to continuously flow and the breakdown can lead smoke or ignition. To minimize the effects of the flow of a large current in case of breakdown, appropriate settings, such as fuse capacity, fusing time and insertion circuit location, are required.
- [4] If your design includes an inductive load such as a motor coil, incorporate a protection circuit into the design to prevent device malfunction or breakdown caused by the current resulting from the inrush current at power ON or the negative current resulting from the back electromotive force at power OFF. IC breakdown may cause injury, smoke or ignition.  
Use a stable power supply with ICs with built-in protection functions. If the power supply is unstable, the protection function may not operate, causing IC breakdown. IC breakdown may cause injury, smoke or ignition.
- [5] Carefully select external components (such as inputs and negative feedback capacitors) and load components (such as speakers), for example, power amp and regulator.  
If there is a large amount of leakage current such as input or negative feedback condenser, the IC output DC voltage will increase. If this output voltage is connected to a speaker with low input withstand voltage, overcurrent or IC failure can cause smoke or ignition. (The over current can cause smoke or ignition from the IC itself.) In particular, please pay attention when using a Bridge Tied Load (BTL) connection type IC that inputs output DC voltage to a speaker directly.

**Points to remember on handling of ICs****(1) Over current Protection Circuit**

Over current protection circuits (referred to as current limiter circuits) do not necessarily protect ICs under all circumstances. If the over current protection circuits operate against the over current, clear the over current status immediately.

Depending on the method of use and usage conditions, such as exceeding absolute maximum ratings can cause the over current protection circuit to not operate properly or IC breakdown before operation. In addition, depending on the method of use and usage conditions, if over current continues to flow for a long time after operation, the IC may generate heat resulting in breakdown.

**(2) Thermal Shutdown Circuit**

Thermal shutdown circuits do not necessarily protect ICs under all circumstances. If the thermal shutdown circuits operate against the over temperature, clear the heat generation status immediately.

Depending on the method of use and usage conditions, such as exceeding absolute maximum ratings can cause the thermal shutdown circuit to not operate properly or IC breakdown before operation.

**(3) Heat Radiation Design**

In using an IC with large current flow such as power amp, regulator or driver, please design the device so that heat is appropriately radiated, not to exceed the specified junction temperature ( $T_j$ ) at any time and condition. These ICs generate heat even during normal use. An inadequate IC heat radiation design can lead to decrease in IC life, deterioration of IC characteristics or IC breakdown. In addition, please design the device taking into consideration the effect of IC heat radiation with peripheral components.

**(4) Back-EMF**

When a motor rotates in the reverse direction, stops or slows down abruptly, a current flows back to the motor's power supply due to the effect of back-EMF. If the current sink capability of the power supply is small, the device's motor power supply and output pins might be exposed to conditions beyond absolute maximum ratings. To avoid this problem, take the effect of back-EMF into consideration in system design.



## RESTRICTIONS ON PRODUCT USE

- Toshiba Corporation, and its subsidiaries and affiliates (collectively "TOSHIBA"), reserve the right to make changes to the information in this document, and related hardware, software and systems (collectively "Product") without notice.
- This document and any information herein may not be reproduced without prior written permission from TOSHIBA. Even with TOSHIBA's written permission, reproduction is permissible only if reproduction is without alteration/omission.
- Though TOSHIBA works continually to improve Product's quality and reliability, Product can malfunction or fail. Customers are responsible for complying with safety standards and for providing adequate designs and safeguards for their hardware, software and systems which minimize risk and avoid situations in which a malfunction or failure of Product could cause loss of human life, bodily injury or damage to property, including data loss or corruption. Before customers use the Product, create designs including the Product, or incorporate the Product into their own applications, customers must also refer to and comply with (a) the latest versions of all relevant TOSHIBA information, including without limitation, this document, the specifications, the data sheets and application notes for Product and the precautions and conditions set forth in the "TOSHIBA Semiconductor Reliability Handbook" and (b) the instructions for the application with which the Product will be used with or for. Customers are solely responsible for all aspects of their own product design or applications, including but not limited to (a) determining the appropriateness of the use of this Product in such design or applications; (b) evaluating and determining the applicability of any information contained in this document, or in charts, diagrams, programs, algorithms, sample application circuits, or any other referenced documents; and (c) validating all operating parameters for such designs and applications. **TOSHIBA ASSUMES NO LIABILITY FOR CUSTOMERS' PRODUCT DESIGN OR APPLICATIONS.**
- **PRODUCT IS NEITHER INTENDED NOR WARRANTED FOR USE IN EQUIPMENTS OR SYSTEMS THAT REQUIRE EXTRAORDINARILY HIGH LEVELS OF QUALITY AND/OR RELIABILITY, AND/OR A MALFUNCTION OR FAILURE OF WHICH MAY CAUSE LOSS OF HUMAN LIFE, BODILY INJURY, SERIOUS PROPERTY DAMAGE AND/OR SERIOUS PUBLIC IMPACT ("UNINTENDED USE").** Except for specific applications as expressly stated in this document, Unintended Use includes, without limitation, equipment used in nuclear facilities, equipment used in the aerospace industry, medical equipment, equipment used for automobiles, trains, ships and other transportation, traffic signaling equipment, equipment used to control combustions or explosions, safety devices, elevators and escalators, devices related to electric power, and equipment used in finance-related fields. **IF YOU USE PRODUCT FOR UNINTENDED USE, TOSHIBA ASSUMES NO LIABILITY FOR PRODUCT.** For details, please contact your TOSHIBA sales representative.
- Do not disassemble, analyze, reverse-engineer, alter, modify, translate or copy Product, whether in whole or in part.
- Product shall not be used for or incorporated into any products or systems whose manufacture, use, or sale is prohibited under any applicable laws or regulations.
- The information contained herein is presented only as guidance for Product use. No responsibility is assumed by TOSHIBA for any infringement of patents or any other intellectual property rights of third parties that may result from the use of Product. No license to any intellectual property right is granted by this document, whether express or implied, by estoppel or otherwise.
- **ABSENT A WRITTEN SIGNED AGREEMENT, EXCEPT AS PROVIDED IN THE RELEVANT TERMS AND CONDITIONS OF SALE FOR PRODUCT, AND TO THE MAXIMUM EXTENT ALLOWABLE BY LAW, TOSHIBA (1) ASSUMES NO LIABILITY WHATSOEVER, INCLUDING WITHOUT LIMITATION, INDIRECT, CONSEQUENTIAL, SPECIAL, OR INCIDENTAL DAMAGES OR LOSS, INCLUDING WITHOUT LIMITATION, LOSS OF PROFITS, LOSS OF OPPORTUNITIES, BUSINESS INTERRUPTION AND LOSS OF DATA, AND (2) DISCLAIMS ANY AND ALL EXPRESS OR IMPLIED WARRANTIES AND CONDITIONS RELATED TO SALE, USE OF PRODUCT, OR INFORMATION, INCLUDING WARRANTIES OR CONDITIONS OF MERCHANTABILITY, FITNESS FOR A PARTICULAR PURPOSE, ACCURACY OF INFORMATION, OR NONINFRINGEMENT.**
- Do not use or otherwise make available Product or related software or technology for any military purposes, including without limitation, for the design, development, use, stockpiling or manufacturing of nuclear, chemical, or biological weapons or missile technology products (mass destruction weapons). Product and related software and technology may be controlled under the applicable export laws and regulations including, without limitation, the Japanese Foreign Exchange and Foreign Trade Law and the U.S. Export Administration Regulations. Export and re-export of Product or related software or technology are strictly prohibited except in compliance with all applicable export laws and regulations.
- Please contact your TOSHIBA sales representative for details as to environmental matters such as the RoHS compatibility of Product. Please use Product in compliance with all applicable laws and regulations that regulate the inclusion or use of controlled substances, including without limitation, the EU RoHS Directive. **TOSHIBA ASSUMES NO LIABILITY FOR DAMAGES OR LOSSES OCCURRING AS A RESULT OF NONCOMPLIANCE WITH APPLICABLE LAWS AND REGULATIONS.**

## X-ON Electronics

Largest Supplier of Electrical and Electronic Components

*Click to view similar products for [Motor/Motion/Ignition Controllers & Drivers](#) category:*

*Click to view products by [Toshiba](#) manufacturer:*

Other Similar products are found below :

[FSB50550TB2](#) [MSVCPM2-63-12](#) [MSVGW45-14-2](#) [MSVGW54-14-3](#) [NTE7043](#) [LA6565VR-TLM-E](#) [LB1837M-TLM-E](#) [STK534U342C-E](#)  
[AM4967GSTR-G1](#) [TB6562AFG\(O,8,EL\)](#) [LA6584JA-AH](#) [LB11961-W-AH](#) [LC898212XD-SH](#) [NCV70501DW002R2G](#) [VNH5200ASTR-E](#)  
[TND315S-TL-2H](#) [FSB50250AB](#) [FNA41060](#) [MSVBTC50E](#) [MSVCPM3-54-12](#) [MSVCPM3-63-12](#) [MSVCPM4-63-12](#) [FSB50550AB](#)  
[L99MC6TR](#) [LC898301XA-MH](#) [LV8413GP-TE-L-E](#) [MSVGW45-14-3](#) [MSVGW54-14-4](#) [IRSM515-025DA4](#) [LB11851FA-BH](#) [STIPN2M50-](#)  
[H](#) [BH67172NUX-GE2](#) [DMPUC-R2](#) [AIS-D-42MA](#) [FNB81560T3](#) [NCV7535DBR2G](#) [NCP81274MNTXG](#) [LB11685AV-W-AH](#)  
[IM240S6Y1BAKMA1](#) [FSB50450BL](#) [FSB50450BSL](#) [FSB50550BSL](#) [IKCM15L60GD](#) [DA7280-00FV2](#) [IM240M6Z1BALMA1](#) [FSB50550BL](#)  
[MP9517GJS-P](#) [TLE9877QXA40XUMA3](#) [BA6868FM-E2](#) [HT8835ARDZ](#)