

# TB9101FNG

## 2ch H-Bridge driver for DC Brushed Motor

TB9101FNG is a 2ch H-bridge driver which is designed specifically for Automotive. This IC has built-in for directly driving small DC Brushed motor.

Forward/Reverse/Stop/Brake can be set by Input signal (DI1A,DI1B,DI2A,DI2B). These Inputs are TTL, thus, TB9101FNG can be controlled by external MCU, directory. Standby mode, Miscellaneous Abnormal Detection are built-in.

TB9101FNG is for wide application such as for Automotive Air-condition system (Dumper control), Door Mirror control.

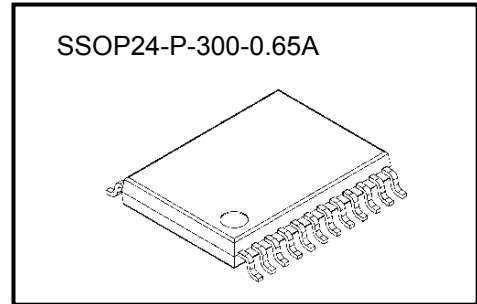

Weight: 0.14 g (typ.)

### Feature

- Motor Driver : 2ch H-Bridge with Driver (Directry drive external Motor)  
RON: RHON(Pch)=0.6Ω(typ.), RLON(Nch)=0.6Ω(typ.)
- Standby mode : 0mA(typ.)
- Operating Voltage range : 7 to 18V (Absolute Maximum Rating 40V)
- Operating Temperature range : -40°C to 125°C
- Miscellaneous Abnormal Detection : Motor Over Current (with Output monitor signal)  
VCC Over Voltage  
VCC Low Voltage  
IC internal Over Temperature
- Package : SSOP24-P-300-0.65A
- AEC-Q100 Qualified
- The product(s) is/are compatible with RoHS regulations (2011 / 65 / EU) as indicated, if any, on the packaging label ("[[G]]/RoHS COMPATIBLE", "[[G]]/RoHS [[Chemical symbol(s) of controlled substance(s)]]", "RoHS COMPATIBLE" or "RoHS COMPATIBLE, [[Chemical symbol(s) of controlled substance(s)]]>MCV").

**INTERNAL BLOCK DIAGRAM AND PIN LAYOUT**

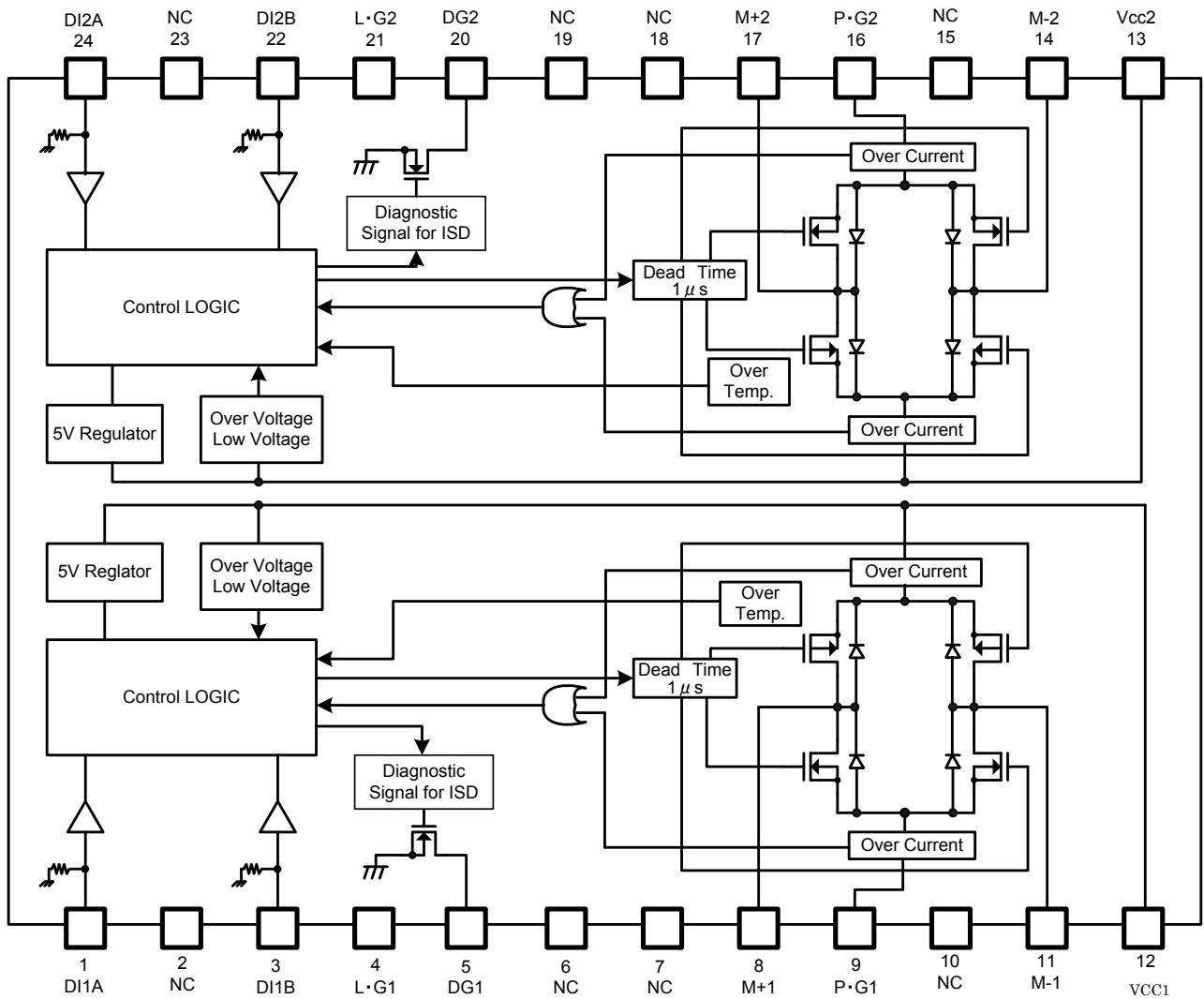

\*1: Some of the functional blocks, circuit, or constants in the block diagram may be omitted or Simplified for explanatory purpose.

\*2: Install the product correctly. Otherwise, it may result in break down, damage and/or deterioration to the product or equipment.

## PIN CONNECTION

PIN No.		PIN NAME		NOTES
CH1	CH2	CH1	CH2	
1	24	DI1A	DI2A	Input for Motor control.(refer to "Motor Operation1" in next page)
3	22	DI1B	DI2B	
4	21	L·G1	L·G2	GND for 5V Circuit.
5	20	DG1	DG2	Over Current Detection Monitor signal. The Output is Open Drain type. When Over Current is detected on each Motor, DG1/DG2 output "L". External Pull Up to 5V is required.
8	17	M +1	M +2	Output for Motor 1,2 driving. Build-in Over Current detection.
9	16	P·G1	P·G2	GND for Motor driving.
11	14	M -1	M -2	Output for Motor 1,2 driving., Build-in Over Current detection
12	13	VCC1	VCC2	12V Power Supply(typ.). Build-in Over/Low Voltage Detecion
2,6,7,10, 15,18,19, 23		NC		no connecton. keep open on PCB

## Internal protection circuit

Terminal No.	Name	Internal Protection circuit
1	DI1A	A Type(VCC1/ L·G1)
2	NC	—
3	DI1B	A Type(VCC1/ L·G1)
4	L·G1	B Type(VCC1)
5	DG1	A Type(VCC1/ L·G1)
6	NC	—
7	NC	—
8	M+1	—
9	P·G1	B Type(VCC1)
10	NC	—
11	M-1	—
12	VCC1	C Type(VCC2/ L·G1)
13	VCC2	C Type(VCC1/ L·G2)
14	M-2	—
15	NC	—
16	P·G2	B Type(VCC2)
17	M+2	—
18	NC	—
19	NC	—
20	DG2	A Type(VCC2/ L·G2)
21	L·G2	B Type(VCC2)
22	DI2B	A Type(VCC2/ L·G2)
23	NC	—
24	DI2A	A Type(VCC2/ L·G2)

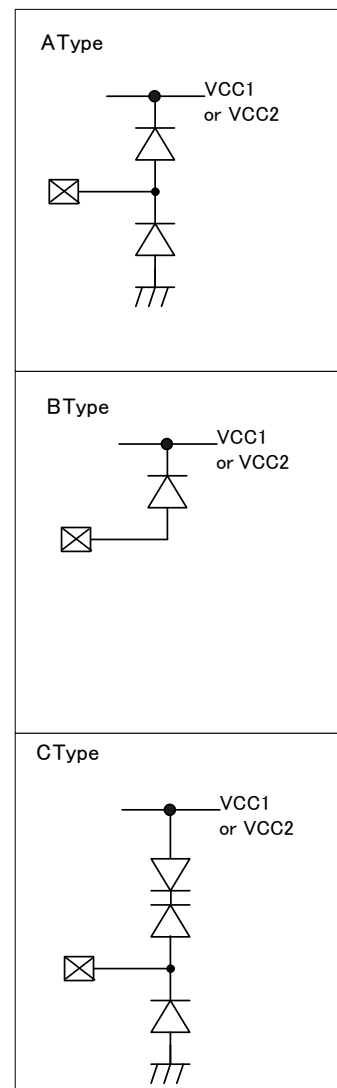

## FUNCTIONAL DESCRIPTION

### (1) Motor control

TB9101FNG build-in 2 H-Bridge. These 2 H-Bridge is controlled by Input DI1A/DI1B DI2A/DI2B, independently. The operation modes are as follows.

#### ·Motor Operation 1

Input		Output		Operation Mode
DI1A / DI2A	DI1B / DI2B	M +1 / M+2	M -1 / M-2	
H	H	L	L	BRAKE
H	L	H	L	FORWARD Rotation(CW)
L	H	L	H	REVERSE Rotation(CCW)
L	L	OFF (Hi-Z)		STANDBY

**CAUTION:** When Motor operation is stopped, it is prefer to go to BRAKE mode, first. Then after reducing Motor rotation speed, goes to STANDBY mode. It can be reducing Motor Back Electromotive Force.

#### ·H-Bridge Circuit in Standby mode and BRAKE mode

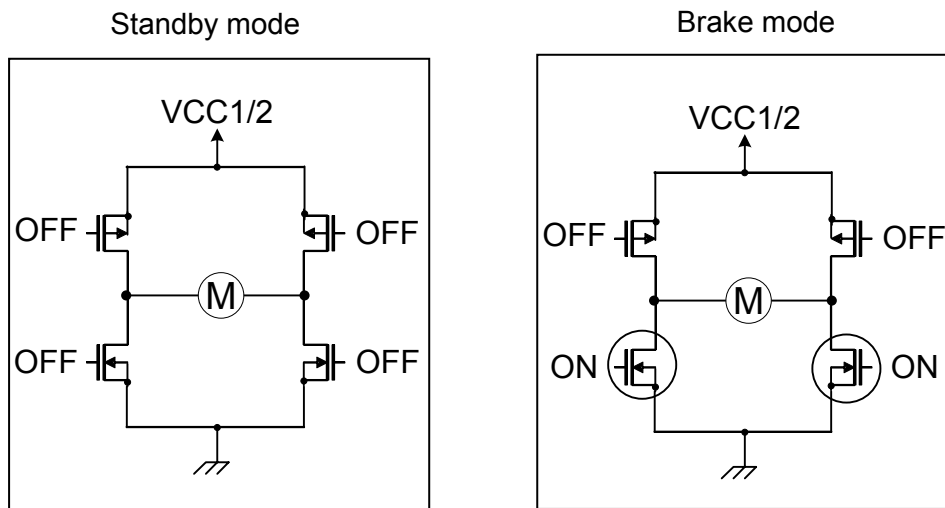

- Standby mode: DI1A/DI1B = "L", DI2A/DI2B = "L"
  - 5V Regulator OFF
  - Motor Drive Output (M+1/M-1, M+2/M-2) OFF(Hi-Z)
  - Abnormal Detection Circuit OFF (VCC Over Voltage, Over Current, Over Temp. VCC Low Voltage)

**·DEAD TIME Generation**

TB9101FNG generate "DEAD TIME" on Motor drive output signal (M+1,M+2,M-1,M-2) which is Hi-Z status during 1 $\mu$ s(typ.) at rising Edge of each Input (DI1A,DI1B,DI2A,DI2B) . This is to protect power short by simultaneous ON of Hi-side and Lo-side MOSFET which consist of the same Half Bridge.

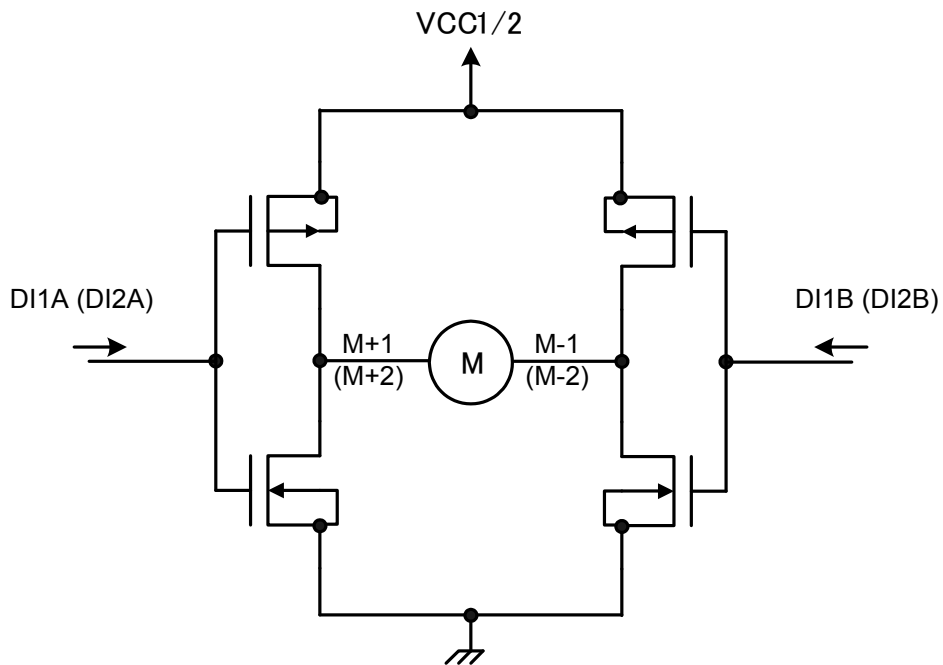
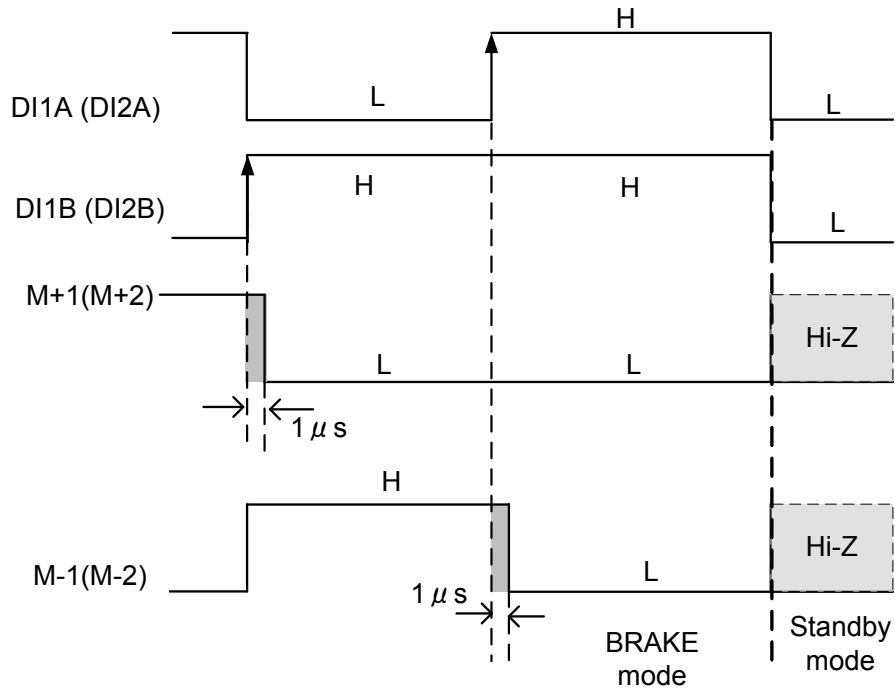

**·Miscellaneous Abnormal Detection**

TB9101FNG has Miscellaneous Abnormal Detection, such as Over Voltage (VSD) for VCC1,VCC2 Motor Over Current (ISD), CHIP inner Over Temperature(TSD), Low Voltage for VCC1,VCC2. These Detection are set for each H-Bridge independently.

**(1). Over Voltage Detection for VCC1,VCC2 (VSD: detection 30V(typ.))**

TB9101FNG has Over Voltage Detection for VCC1 and VCC2, independently. When each voltage is over 30V(typ.), the driver of that H-Bridge Output is turned OFF(Hi-Z). When the voltage drop to lower than 27V(typ.), the driver return to normal operation which is controlled by each Input (DI1A,DI1B,DI2A,DI2B). The internal signal of Over Voltage Detection has chattering protection circuit. If the voltage continues to exceed the Over Voltage Detection value, though the state of the Over Voltage Detection is released by the above mentioned, the Over Voltage Detection is enabled again, and each output of the motor driver is turned OFF(Hi-Z) again.

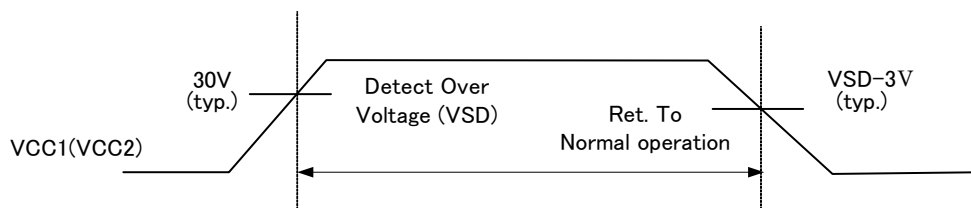

**CAUTION1:**This Over Voltage Detection is not to clamp Battery Voltage for TB9101FNG Thus, the system should keep lower operation voltage than the Maximum rating Spec.

**(2). Over Temperature Detection (TSD: detection typ.170°C)**

TB9101FNG has Over Temperature Detection for each internal H-Bridge, independently. When the Temp of H-Bridge is over 170°C.(typ.), that H-Bridge Output is turned OFF(Hi-Z). After detecting TSD, when that H-Bridge Temp. drop to lower than TSD-10°C (typ.), the driver return to normal operation which is controlled by each Input (DI1A,DI1B,DI2A,DI2B) The internal signal of Over Temperature Detection has chattering protection circuit. If the temperature continues to exceed the Over Temperature Detection value, though the state of the Over Temperature Detection is released by the above-mentioned, the Over Temperature Detection is enabled again, and each output of the motor driver is turned OFF(Hi-Z) again.

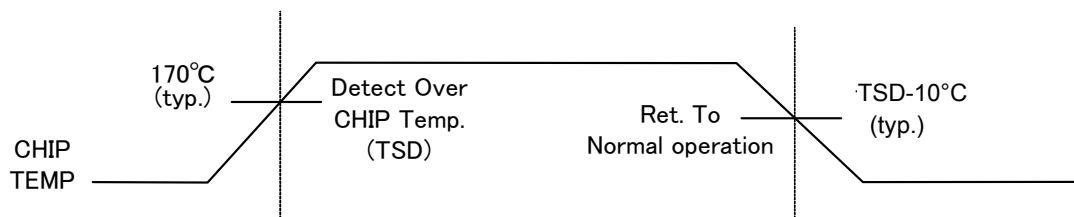

**CAUTION2:** The Absolute maximum Temperature of TB9101FNG is 150°C(Max). This Over Temperature Detection function does not intend to limit the CHIP temperature. Thus, the above Absolute Maximum Temperature never is over to use TB9101FNG. If any of these rating would be exceeded during operation, the device electrical characteristics may be irreparably altered and the reliability and lifetime of the device can no longer be guaranteed. Moreover, these operations with exceeded ratings may cause break down, damage and/or degradation to any other equipment. Applications using the device should be designed such that each maximum rating will never be exceeded in any operating conditions. Before using, creating and/or producing designs, refer

to and comply with the precautions and conditions set forth in this documents.  
 In addition, this IC has a built-in over-temperature detection function, but this function does not reduce to 170 °C below the temperature of the IC.  
 Also for the function of the operation guarantee range, please use as an auxiliary.  
 This Over Temp. Detection is worded over the Max. Rating Temperature and shipping test does not perform at the Max. Rating Temp.

**(3). Over Current Detection (ISD: detection typ. 1.5A )**

TB9101FNG has Over Current of Motor Detection for each H-Bridge independently. When Motor Current is over  $\pm 1.5A$ (typ.), that H-Bridge Output is turned OFF(Hi-Z), and each Diagnostic signal (DG1,DG2) is changed to "L". This Diagnostic signal DG1 and DG2 are the Output of Open-Drain typ. Thus, the status in normal operation is "Hi-Z" and external Pull up to 5V power line is required. After detecting Over Current of each H-Bridge, that Output for Motor drive are kept OFF(Hi-Z) and Diagnostic signal of each H-Bridge(DG1, DG2) is kept "L", even the Current return to normal level. This Over Current Detection condition can be reset by going to Standby mode (DI1A=DI1B=L or DI2A=DI2B=L). The internal signal of Over Current Detection and Release has a chattering protection circuit to prevent malfunction. If the Motor Current is still over after reset by Standby mode operation, TB9101FNG detect it after going to Motor operation from Standby mode (change anyone of that H-bridge Input (DI1A/DI1B or DI2A/DI2B) to "H"), and change Motor drive Output to Hi-Z and output "L" from each DG1/DG2, again. When VCC Low Voltage is detected (5v typ.) after Over Current detection, Over Current detection status is reset by Power On Reset. Thus, in this case, even the Voltage return to normal and mode return to normal operation, previous Over Current Detection status does not be held. The internal signal of Over Current Detection has chattering protection circuit.

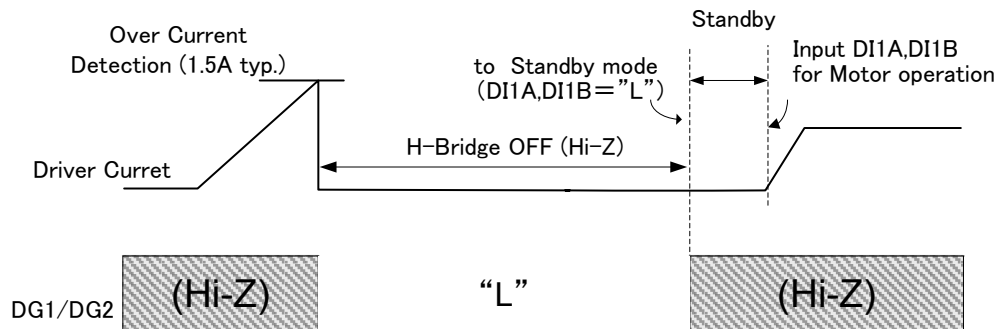

**CAUTION:**Over Current Detection circuits is only intended to provide temporary protection against irregular conditions such as an output short-circuit; they do not necessarily guarantee the complete IC safety. Therefore, output short-circuit(short to VCC or GND) the ground fault Since the IC may be destroyed, the design of routing output line, VCC, and GND lines sufficient attention Please.

**(4) Low Voltage Detection for VCC1,VCC2 (detection typ. 5V)**

TB9101FNG has Low Voltage Detection for VCC1 and VCC2, independently. When each voltage drop to lower than 5V(typ.), Power On Reset is done and the Output of that H-Bridge is turned OFF(Hi-Z). Also Over Current Detection and Over Temperature Detection are OFF. When the voltage rise up to 5.5V (typ.), the driver return to normal operation which is controlled by each Input (DI1A,DI1B,DI2A,DI2B).

Release signal and Low Voltage Detection is designed to prevent a malfunction and a built-in chattering prevention circuit.

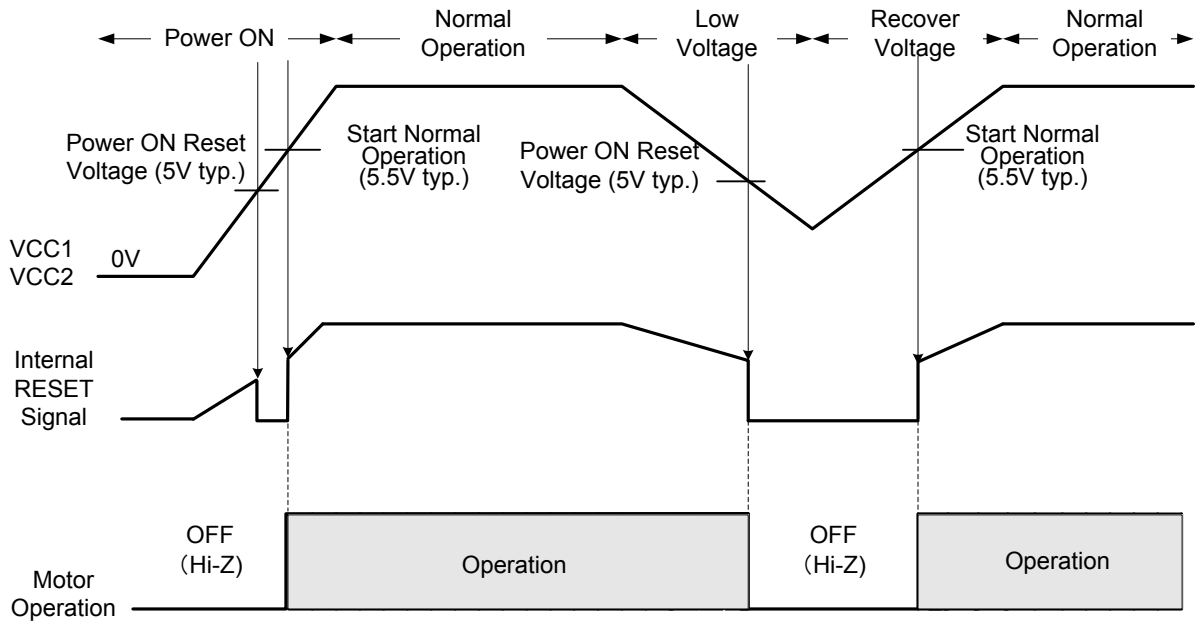



## ELECTRICAL CHARACTERISTICS

### (1) ABSOLUTE MAXIMUM RATING (Ta=25°C)

ITEM	SYMBOL	PIN	CONDITION	RATING	UNIT
Supply Voltage	VCC	VCC1,VCC2	DC Voltage	-0.3 to +40	V
Output Current	IOUT	M+1, M-1, M+2, M-2	at Current Detection	±1.5	A
			—	±1.0	
	IOL	DG1,DG2	—	+2.5	mA
Input Voltage	VIN	DI1A, DI1B DI2A, DI2B	—	-0.3 to +40	V
Output Voltage	VOUT	M+1, M-1, M+2, M-2	—	-0.3 to +40	V
		DG1,DG2	—		
Operating Temp.	Topr	—	—	-40 to +125	°C
Storage Temp.	Tstg	—	—	-55 to +150	
Soldering Temp./Time	Tsol	—	Manual Soldering	260 (10s)	
Power Dissipation	PD	—	PCB 76.2×114.3×t1.6mm Mono Layer, Cu:30%	1.32	W

**CAUTION 1:**The above current spec. value of “+” is Input from outside,”-“ is Output from TB9101FNG.

**CAUTION 2:** Please do not exceed the absolute maximum rating, including the reverse voltage.

**CAUTION 3:**The absolute maximum ratings of a semiconductor device are a set of specified parameter values, which must not be exceeded during operation, even for an instant. If any of these rating would be exceeded during operation, the device electrical characteristics may be irreparably altered and the reliability and lifetime of the device can no longer be guaranteed. Moreover, these operations with exceeded ratings may cause break down, damage and/or degradation to any other equipment. Applications using the device should be designed such that each maximum rating will never be exceeded in any operating conditions. Before using, creating and/or producing designs, refer to and comply with the precautions and conditions set forth in these documents.

### Package (SSOP24-P-300-0.65A) Thermal Resistance

ITEM	SYMBOL	RATING	CONDITION	UNIT
Thermal Resistance	Rθj-a	160	IC	°C/W
		95	PCB Mono Layer, size:76.2×114.3×t1.6mm, Cu:30%, Cu thickness:35μm	°C/W
		60	PCB 4Layer, size:76.2×114.3×t1.6mm Cu:30%, Cu thickness:35μm	°C/W

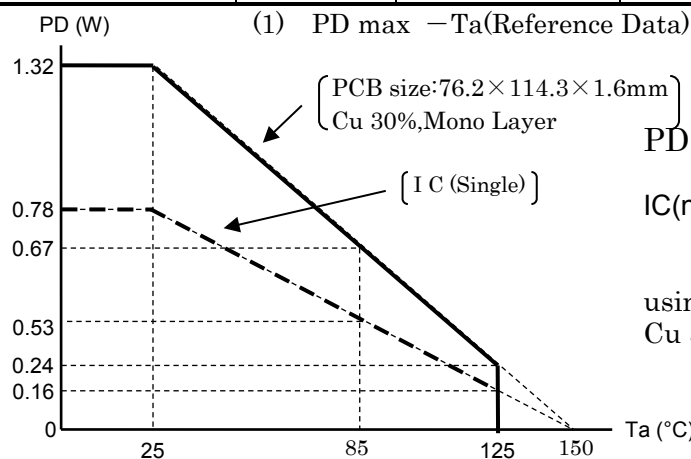

$$PD = (150 - Ta) / R\theta j-a$$

IC(no PCB) at 25°C.  
 $(150-25)/160 = 0.781 (W)$

using PCB(Mono Layer) size:76.2×114.3×1.6mm  
 Cu 30% at 25°C.  
 $(150-25)/95 = 1.32(W)$

## ELECTRICAL CHARACTERISTICS (cont.)

### (2) IC CHARACTERISTICS

The following are under condition VCC1,VCC2 = 7 to 18V, Ta=-40 to 125°C. unless otherwise follows

ITEM	SYMBOL	PIN	Condition	MIN	TYP.	MAX	UNIT
Current Consumption (No Load)	ICC	VCC1+VCC2	CH1 or 2 CW or CCW CH1+2 CW or CCW CH1+2 BRAKE	—	—	7	mA
Standby Current	Istby	VCC1, VCC2	DI1A,DI2A,DI1B, DI2B=L	—	0	10	μA
Input Voltage	VIL	DI1A, DI1B, DI2A, DI2B	—	—	—	0.8	V
	VIH		—	2.0	—	—	
Input Current	IIL	DI1A, DI1B, DI2A, DI2B	VIN=0.4V	—	5	10	μA
	IIH		VIN=5V	10	50	100	
Output Voltage "L"	VOL	DG1, DG2	IOL=2.5mA	—	—	0.4	V
Input Current "H"	IIH	DG1, DG2	V(DG1,DG2)=18V	—	—	10	μA

**·ELECTRICAL CHARACTERISTICS (cont.)**

**(3) MOTOR DRIVER**

The following are under condition VCC1,VCC2 = 7 to 18V, Ta=-40 to 125°C. unless otherwise follows

ITEM	SYMBOL	PIN	Condition	MIN	TYP.	MAX	UNIT
H-side Output ON Resistance	RHON	M+1, M-1 M+2, M-2	IOUT=-0.5A, Ta=+25°C	-	0.60	1.2	Ω
			IOUT=-0.5A, Ta=125°C	-	1.0	-	
			IOUT=-0.5A, Ta=-40°C	0.22	0.44	-	
L-side Output ON Resistance	RLON		IOUT=+0.5A, Ta=+25°C	-	0.60	1.2	
			IOUT=+0.5A, Ta=125°C	-	1.0	-	
			IOUT=+0.5A, Ta=-40°C	0.23	0.46	-	
Output OFF Leak Current	ILO	Output OFF VOUT=0V	-10	-	-	μA	
		Output OFF VOUT=VCC1, 2	-	-	10		
Output Delay Time	tpHL		Rload=100Ω	-	3	10	μs
	tpLH		Rload=100Ω	-	3	10	

**CAUTION:**When Motor is rotated, it makes Electromotive Force. The Electrical Specification must be kept, even with this Electromotive Force.

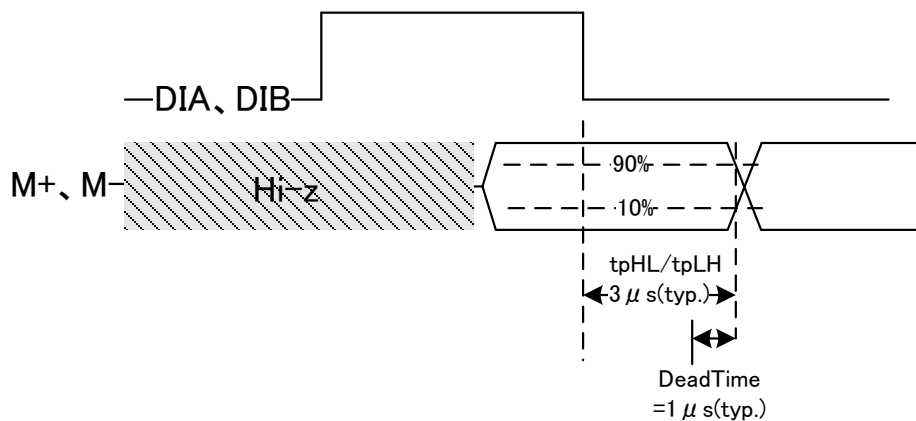

## ·ELECTRICAL CHARACTERISTICS (cont.)

### (4) ABNORMAL DETECTION

The following are under condition VCC1,VCC2 = 7 to 18V, Ta=-40 to 125°C. Unless otherwise follows

ITEM	SYMBOL	PIN	Condition	MIN	TYP.	MAX	UNIT
Over Voltage Detection ON	VSD	VCC1 VCC2	-	27	30	33	V
Over Voltage Detection OFF	VSD(hys)			-	VSD-3	-	
Over Temperature Detection ON	TSD	-	*1	150	170	190	°C
Over Temperature Detection OFF	TSD(hys)			TSD-5	TSD-10	TSD-20	
Over Current Detection	ISD	M+1, M-1 M+2, M-2	-	±1	±1.5	±2.5	A
Low Voltage Detection ON	VRSTH	VCC1, VCC2		-	5.0	-	V
Low Voltage Detection OFF	VRSTL	VCC1, VCC2		4.5	5.5	6.0	

Note \*1: Impossible to test in mass production

**REFERENCE APPLICATION CIRCUIT DIAGRAM**

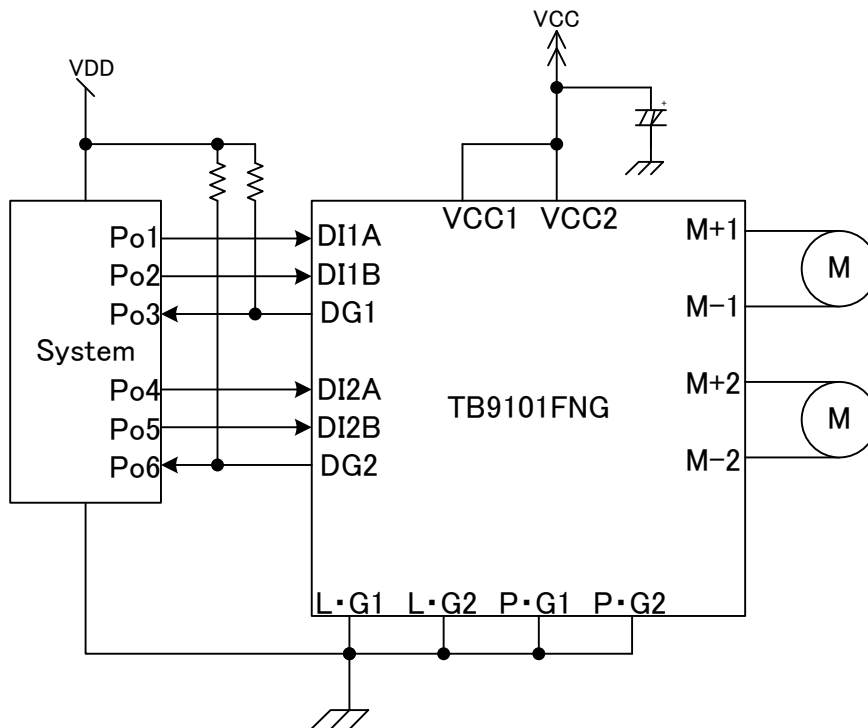

- CAUTION1:** The capacitor connected to VCC, and connect to absorb, such as voltage fluctuations due to motor load variation and noise from the outside.  
Therefore, please be connected as close to the IC as much as possible.
- CAUTION2:** Install the product correctly. Otherwise, it may result in break down, damage and/or deterioration to the product or equipment.
- CAUTION3:** The application circuits shown in this document are provided for reference purposes only. Especially, a thorough evaluation is required on the phase of mass production design.  
Toshiba dose not grant the use of any industrial property rights with these examples of application circuits.
- CAUTION4:** Short Circuit between each Output signal, Output Signal and Power line (Battery, Regurator Output, GND) may make the cause of IC distruction or Damage.
- CAUTION5:** Overvoltage detection function does not clamp the power potential.  
VCC supply must be protected externally so as not to absolute maximum ratings over.

PACKAGE

SSOP24-P-300-0.65A

Unit: mm

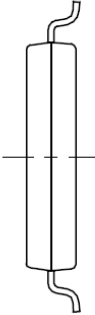
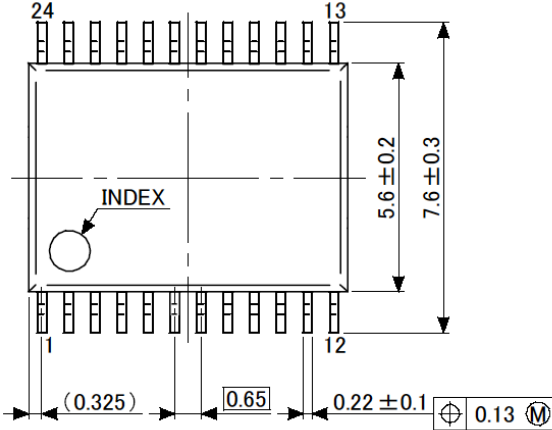

Detailed diagram of tip of terminal

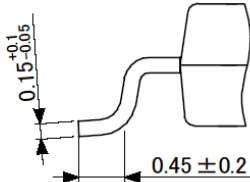
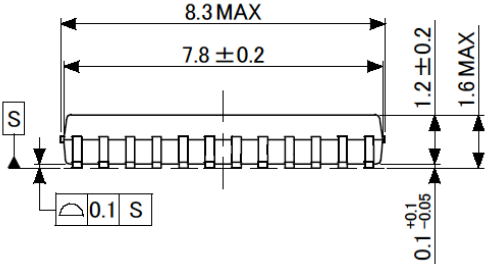

Weight: 0.14 g (typ.)

**【CAUTION】**

- Some of the functional blocks, circuits, or constants in the block diagram may be omitted or Simplified for explanatory purpose.
- The equivalent circuit diagrams may be simplified or some parts of them may be omitted for explanatory purpose.
- Timing charts may be simplified for explanatory purpose.
- The absolute maximum ratings of a semiconductor device are a set of specified parameter values, which must not be exceeded during operation, even for an instant. If any of these rating would be exceeded during operation, the device electrical characteristics may be irreparably altered and the reliability and lifetime of the device can no longer be guaranteed. Moreover, these operations with exceeded ratings may cause break down, damage and/or degradation to any other equipment. Applications using the device should be designed such that each maximum rating will never be exceeded in any operating conditions. Before using, creating and/or producing designs, refer to and comply with the precautions and conditions set forth in this documents.
- Ensure that the IC is mounted correctly. Failing to do so may result in the IC or target equipment being damage

## RESTRICTIONS ON PRODUCT USE

Toshiba Corporation and its subsidiaries and affiliates are collectively referred to as "TOSHIBA". Hardware, software and systems described in this document are collectively referred to as "Product".

- TOSHIBA reserves the right to make changes to the information in this document and related Product without notice.
- This document and any information herein may not be reproduced without prior written permission from TOSHIBA. Even with TOSHIBA's written permission, reproduction is permissible only if reproduction is without alteration/omission.
- Though TOSHIBA works continually to improve Product's quality and reliability, Product can malfunction or fail. Customers are responsible for complying with safety standards and for providing adequate designs and safeguards for their hardware, software and systems which minimize risk and avoid situations in which a malfunction or failure of Product could cause loss of human life, bodily injury or damage to property, including data loss or corruption. Before customers use the Product, create designs including the Product, or incorporate the Product into their own applications, customers must also refer to and comply with (a) the latest versions of all relevant TOSHIBA information, including without limitation, this document, the specifications, the data sheets and application notes for Product and the precautions and conditions set forth in the "TOSHIBA Semiconductor Reliability Handbook" and (b) the instructions for the application with which the Product will be used with or for. Customers are solely responsible for all aspects of their own product design or applications, including but not limited to (a) determining the appropriateness of the use of this Product in such design or applications; (b) evaluating and determining the applicability of any information contained in this document, or in charts, diagrams, programs, algorithms, sample application circuits, or any other referenced documents; and (c) validating all operating parameters for such designs and applications. **TOSHIBA ASSUMES NO LIABILITY FOR CUSTOMERS' PRODUCT DESIGN OR APPLICATIONS.**
- **PRODUCT IS NEITHER INTENDED NOR WARRANTED FOR USE IN EQUIPMENTS OR SYSTEMS THAT REQUIRE EXTRAORDINARILY HIGH LEVELS OF QUALITY AND/OR RELIABILITY, AND/OR A MALFUNCTION OR FAILURE OF WHICH MAY CAUSE LOSS OF HUMAN LIFE, BODILY INJURY, SERIOUS PROPERTY DAMAGE AND/OR SERIOUS PUBLIC IMPACT ("UNINTENDED USE").** Except for specific applications as expressly stated in this document, Unintended Use includes, without limitation, equipment used in nuclear facilities, equipment used in the aerospace industry, and lifesaving and/or life supporting medical equipment. **IF YOU USE PRODUCT FOR UNINTENDED USE, TOSHIBA ASSUMES NO LIABILITY FOR PRODUCT.** For details, please contact your TOSHIBA sales representative or contact us via our website.
- Do not disassemble, analyze, reverse-engineer, alter, modify, translate or copy Product, whether in whole or in part.
- Product shall not be used for or incorporated into any products or systems whose manufacture, use, or sale is prohibited under any applicable laws or regulations.
- The information contained herein is presented only as guidance for Product use. No responsibility is assumed by TOSHIBA for any infringement of patents or any other intellectual property rights of third parties that may result from the use of Product. No license to any intellectual property right is granted by this document, whether express or implied, by estoppel or otherwise.
- **ABSENT A WRITTEN SIGNED AGREEMENT, EXCEPT AS PROVIDED IN THE RELEVANT TERMS AND CONDITIONS OF SALE FOR PRODUCT, AND TO THE MAXIMUM EXTENT ALLOWABLE BY LAW, TOSHIBA (1) ASSUMES NO LIABILITY WHATSOEVER, INCLUDING WITHOUT LIMITATION, INDIRECT, CONSEQUENTIAL, SPECIAL, OR INCIDENTAL DAMAGES OR LOSS, INCLUDING WITHOUT LIMITATION, LOSS OF PROFITS, LOSS OF OPPORTUNITIES, BUSINESS INTERRUPTION AND LOSS OF DATA, AND (2) DISCLAIMS ANY AND ALL EXPRESS OR IMPLIED WARRANTIES AND CONDITIONS RELATED TO SALE, USE OF PRODUCT, OR INFORMATION, INCLUDING WARRANTIES OR CONDITIONS OF MERCHANTABILITY, FITNESS FOR A PARTICULAR PURPOSE, ACCURACY OF INFORMATION, OR NONINFRINGEMENT.**
- Do not use or otherwise make available Product or related software or technology for any military purposes, including without limitation, for the design, development, use, stockpiling or manufacturing of nuclear, chemical, or biological weapons or missile technology products (mass destruction weapons). Product and related software and technology may be controlled under the applicable export laws and regulations including, without limitation, the Japanese Foreign Exchange and Foreign Trade Law and the U.S. Export Administration Regulations. Export and re-export of Product or related software or technology are strictly prohibited except in compliance with all applicable export laws and regulations.
- Please contact your TOSHIBA sales representative for details as to environmental matters such as the RoHS compatibility of Product. Please use Product in compliance with all applicable laws and regulations that regulate the inclusion or use of controlled substances, including without limitation, the EU RoHS Directive. **TOSHIBA ASSUMES NO LIABILITY FOR DAMAGES OR LOSSES OCCURRING AS A RESULT OF NONCOMPLIANCE WITH APPLICABLE LAWS AND REGULATIONS.**

---

**TOSHIBA ELECTRONIC DEVICES & STORAGE CORPORATION**

<https://toshiba.semicon-storage.com/>



## X-ON Electronics

Largest Supplier of Electrical and Electronic Components

*Click to view similar products for [Motor/Motion/Ignition Controllers & Drivers](#) category:*

*Click to view products by [Toshiba](#) manufacturer:*

Other Similar products are found below :

[FSB50550TB2](#) [FSBF15CH60BTH](#) [MSVCPM2-63-12](#) [MSVGW45-14-2](#) [MSVGW54-14-3](#) [MSVGW54-14-5](#) [NTE7043](#) [LA6565VR-TLM-E](#)  
[LB11650-E](#) [LB1837M-TLM-E](#) [LB1845DAZ-XE](#) [LC898300XA-MH](#) [SS30-TE-L-E](#) [26700](#) [LV8281VR-TLM-H](#) [BA5839FP-E2](#) [IRAM236-1067A](#) [LA6584JA-AH](#) [LB11847L-E](#) [AH293-PL-B](#) [TND315S-TL-2H](#) [FNA23060](#) [FSB50250AB](#) [FNA41060](#) [MSVB54](#) [MSVBTC50E](#)  
[MSVCPM3-54-12](#) [MSVCPM3-63-12](#) [MSVCPM4-63-12](#) [MSVTA120](#) [FSB50550AB](#) [NCV70501DW002G](#) [LC898301XA-MH](#) [LV8413GP-TE-L-E](#) [MSVGW45-14-3](#) [MSVGW45-14-4](#) [MSVGW45-14-5](#) [MSVGW54-14-4](#) [STK984-091A-E](#) [SLA7026M](#) [MP6519GQ-Z](#) [LB11651-E](#)  
[IRSM515-025DA4](#) [LV8127T-TLM-H](#) [MC33812EKR2](#) [NCP81382MNTXG](#) [TDA21801](#) [LB11851FA-BH](#) [NCV70627DQ001R2G](#)  
[LB1938FAGEVB](#)