

TC7PCI3212MT, TC7PCI3215MT

1. Functional Description

- 2 Differential Channel, 2:1 multiplexer/demultiplexer switch for PCI Express Gen3

2. General

The TC7PCI3212MT and TC7PCI3215MT are 2 differential channel, 1-2 multiplexer/demultiplexer for PCI Express Gen3 (8Gbps), or other high-speed interface applications.

The An+/An- inputs is connected to the Bn+/Bn- or Cn+/Cn- outputs determined by the combination both the select input (SEL) and output enable (\overline{OE}). When the output enable (\overline{OE}) input is held high-level, the switches are open (high-impedance state) with regardless the state of select inputs and reducing consumption current.

All inputs are equipped with protection circuits against static discharge.

3. Features

- (1) Operating voltage: $V_{CC} = 3.0$ to 3.6 V
- (2) Switch terminal ON-capacitance: $C_{IO} = 1.5$ pF Switch On (typ.) @ $V_{CC} = 3.3$ V
- (3) ON resistance: $R_{ON} = 7.5 \Omega$ (typ.) @ $V_{CC} = 3.0$ V, $V_{IS} = 0$ V
- (4) -3dB Bandwidth: $BW = 11.5$ GHz (typ.) @ $V_{CC} = 3.3$ V
- (5) Insertion Loss: $DDIL = -1$ dB (typ.) @ $V_{CC} = 3.3$ V, $f = 4$ GHz
- (6) Off Isolation: $DDOIRR = -20$ dB (typ.) @ $V_{CC} = 3.3$ V, $f = 4$ GHz
- (7) Crosstalk: $DDNEXT = -40$ dB (typ.) @ $V_{CC} = 3.3$ V, $f = 4$ GHz
- (8) ESD performance: Machine model $\geq \pm 200$ V, Human body model $\geq \pm 2000$ V
- (9) Package: TQFN20

4. Packaging

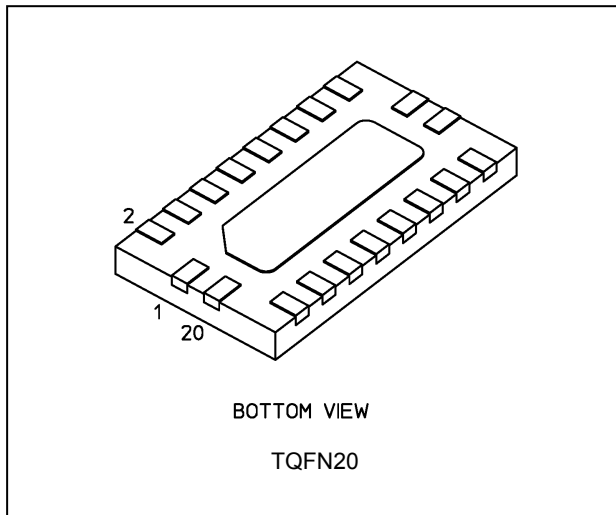

5. Marking

TC7PCI3212MT

TC7PCI3215MT

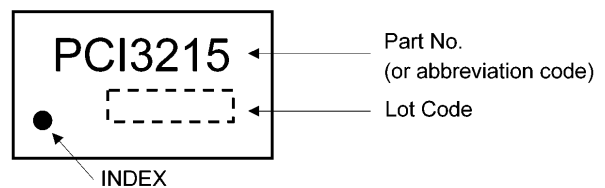
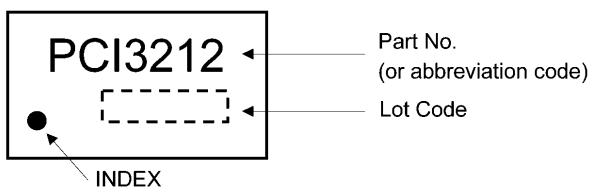

6. Pin Assignment

TC7PCI3212MT

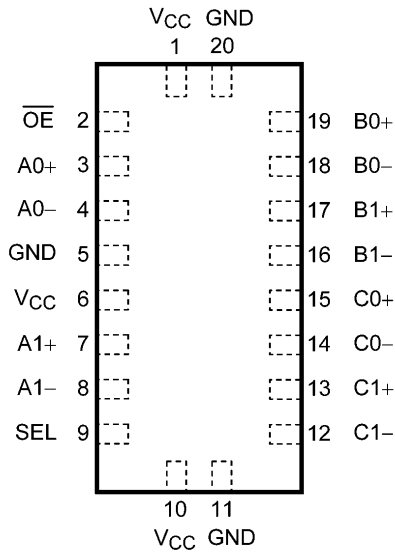

TC7PCI3215MT

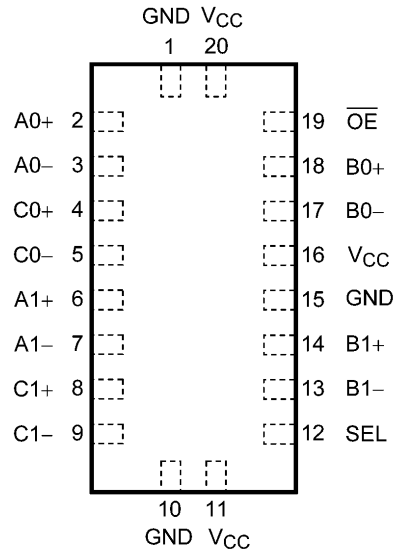

7. Block Diagram

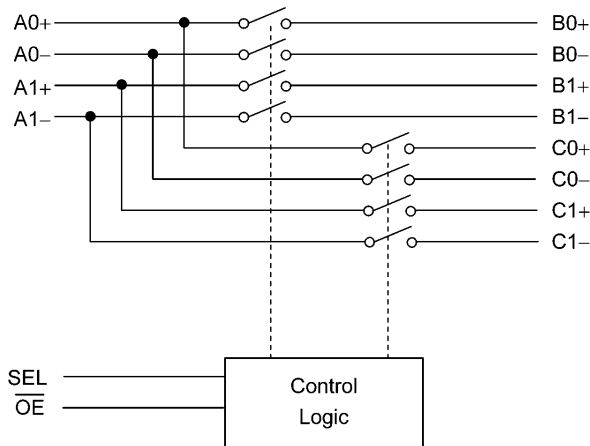

8. Principle of Operation

8.1. Truth Table

Inputs OE	Inputs SEL	Function	Function
L	L	An+ port = Bn+ port, An- port = Bn- port	(n=0,1)
L	H	An+ port = Cn+ port, An- port = Cn- port	(n=0,1)
H	—	An, Bn, Cn port Disconnect	(n=0,1)

—: Don't care.

9. Absolute Maximum Ratings (Note)

Characteristics	Symbol	Note	Rating	Unit
Supply voltage	V_{CC}		-0.5 to 4.6	V
Input voltage (\overline{OE} , SEL)	V_{IN}		-0.5 to 4.6	V
Switch I/O voltage	V_S		-0.5 to $V_{CC} + 0.5$	V
Switch I/O current	I_S		50	mA
Power dissipation	P_D		500	mW
V_{CC} /ground current	I_{CC}/I_{GND}		± 50	mA
Storage temperature	T_{stg}		-55 to 125	$^{\circ}C$

Note: Exceeding any of the absolute maximum ratings, even briefly, lead to deterioration in IC performance or even destruction.

Using continuously under heavy loads (e.g. the application of high temperature/current/voltage and the significant change in temperature, etc.) may cause this product to decrease in the reliability significantly even if the operating conditions (i.e. operating temperature/current/voltage, etc.) are within the absolute maximum ratings and the operating ranges.

Please design the appropriate reliability upon reviewing the Toshiba Semiconductor Reliability Handbook (“Handling Precautions”/“Derating Concept and Methods”) and individual reliability data (i.e. reliability test report and estimated failure rate, etc).

10. Operating Ranges (Note)

Characteristics	Symbol	Note	Rating	Unit
Supply voltage	V_{CC}		3.0 to 3.6	V
Input voltage (\overline{OE} , SEL)	V_{IN}		0 to 3.6	V
Switch I/O voltage	V_S		0 to V_{CC}	V
Operating temperature	T_{opr}		-40 to 85	$^{\circ}C$
Input rise time	dt/dv		0 to 10	ns/V
Input fall time	dt/dv		0 to 10	ns/V

Note: The operating ranges must be maintained to ensure the normal operation of the device.
Unused control inputs must be tied to either V_{CC} or GND.

11. Electrical Characteristics

11.1. DC Characteristics (Note) (Unless otherwise specified, $T_a = -40$ to $85^{\circ}C$)

Characteristics	Symbol	Note	Test Condition	V_{CC} (V)	Min	Typ.	Max	Unit
High-level input voltage (\overline{OE} , SEL)	V_{IH}		—	3.0 to 3.6	$0.65 \times V_{CC}$	—	—	V
Low-level input voltage (\overline{OE} , SEL)	V_{IL}		—	3.0 to 3.6	—	—	$0.35 \times V_{CC}$	V
Input leakage current (\overline{OE} , SEL)	I_{IN}		$V_{IN} = 0$ to 3.6 V	3.0 to 3.6	—	—	± 1	μA
Switch OFF-state leakage current	I_{SZ}		$V_{IS} = 0$ to V_{CC} , $\overline{OE} = V_{CC}$	3.0 to 3.6	—	—	± 1	μA
ON-resistance	R_{ON}	(Note 1)	$V_{IS} = 0$ V, $I_{IS} = 30$ mA	3.0	—	7.5	11.5	Ω
	R_{ON}	(Note 1)	$V_{IS} = 1.2$ V, $I_{IS} = 30$ mA	3.0	—	8.5	13.5	Ω
Difference of ON-resistance between switches (bit to bit)	ΔR_{ON}	(Note 1)	$V_{IS} = 0$ V, 1.2 V, $I_{IS} = 15$ mA	3.0	—	0.1	—	Ω
ON-resistance flatness	$R_{ON(Flat)}$	(Note 1)	$V_{IS} = 0$ V to 1.2 V, $I_{IS} = 15$ mA	3.0	—	1	—	Ω
Quiescent supply current	I_{CC}		$V_{IN} = V_{CC}$ or GND, $\overline{OE} = V_{CC}$	3.6	—	—	1	μA
Quiescent supply current	I_{CC}		$V_{IN} = V_{CC}$ or GND, $\overline{OE} = GND$	3.6	—	200	500	μA

Note : All typical values are at $T_a = 25^{\circ}C$.

Note 1: ON-resistance is measured by measuring the voltage drop across the switch at the indicated current.

11.2. AC Characteristics (Note) (Unless otherwise specified, $T_a = -40$ to 85 °C)

Characteristics	Symbol	Note	Test Condition	V_{CC} (V)	Min	Typ.	Max	Unit
Propagation delay time	t_{PLH}/t_{PHL}	(Note 1)	$C_L = 5$ pF See Fig. 12.1	3.3 ± 0.3	—	0.1	—	ns
Turn-ON time (SEL to Output)	t_{on}		$R_L = 50$ Ω , $C_L = 5$ pF See Fig. 12.2	3.3 ± 0.3	—	10	15	ns
Turn-ON time (\overline{OE} to Output)	t_{on}		$R_L = 50$ Ω , $C_L = 5$ pF See Fig. 12.2	3.3 ± 0.3	—	37	50	μ s
Turn-OFF time (SEL to Output)	t_{off}		$R_L = 50$ Ω , $C_L = 5$ pF See Fig. 12.2	3.3 ± 0.3	—	3.5	5	ns
Turn-OFF time (\overline{OE} to Output)	t_{off}		$R_L = 50$ Ω , $C_L = 5$ pF See Fig. 12.2	3.3 ± 0.3	—	5	6.5	ns
Break before make	TBBM		$R_L = 50$ Ω , $C_L = 5$ pF See Fig. 12.3	3.3 ± 0.3	3	—	9	ns
Output skew (bit to bit)	$t_{SK(b)}$	(Note 1)	$C_L = 5$ pF See Fig. 12.4	3.3 ± 0.3	—	5	—	ps
Output skew (channel to channel)	$t_{SK(CH)}$	(Note 1)	$C_L = 5$ pF See Fig. 12.5	3.3 ± 0.3	—	10	—	ps
Differential OFF isolation	DDOIRR	(Note 1)	$R_T = 50$ Ω , $f = 4$ GHz See Fig. 12.6	3.3 ± 0.3	—	-20	—	dB
Differential Near-end crosstalk	DDNEXT	(Note 1)	$R_T = 50$ Ω , $f = 4$ GHz See Fig. 12.7	3.3 ± 0.3	—	-40	—	dB
Differential return loss	DDRL	(Note 1)	$R_T = 50$ Ω , $f = 4$ GHz See Fig. 12.8	3.3 ± 0.3	—	-20	—	dB
Differential insertion loss	DDIL	(Note 1)	$R_T = 50$ Ω , $f = 4$ GHz See Fig. 12.8	3.3 ± 0.3	—	-1	—	dB
-3dB Bandwidth	BW	(Note 1)	$R_T = 50$ Ω , $C_L = 0$ pF See Fig. 12.8	3.3 ± 0.3	—	11.5	—	GHz

Note : All typical values are at $T_a = 25$ °C.

Note 1: This parameter is guaranteed by design.

11.3. Capacitive Characteristics (Note) (Unless otherwise specified, $T_a = 25$ °C)

Characteristics	Symbol	Note	Test Condition	V_{CC} (V)	Typ.	Unit
Input capacitance (\overline{OE} , SEL)	C_{IN}		$V_{IN} = 0$ V	3.3	3	pF
Switch terminal OFF-capacitance (A_n+ , A_n-)	$C_{I/O}$		$\overline{OE} = V_{CC}$, $V_{IS} = 0$ V	3.3	0.8	pF
Switch terminal OFF-capacitance (B_n+ , B_n- , C_n+ , C_n-)			$\overline{OE} = V_{CC}$, $V_{IS} = 0$ V	3.3	0.5	pF
Switch terminal ON-capacitance	$C_{I/O}$		$\overline{OE} = GND$, $V_{IS} = 0$ V	3.3	1.5	pF

Note: Parameter guaranteed by design.

12. AC Electrical Test Circuit (Fig)

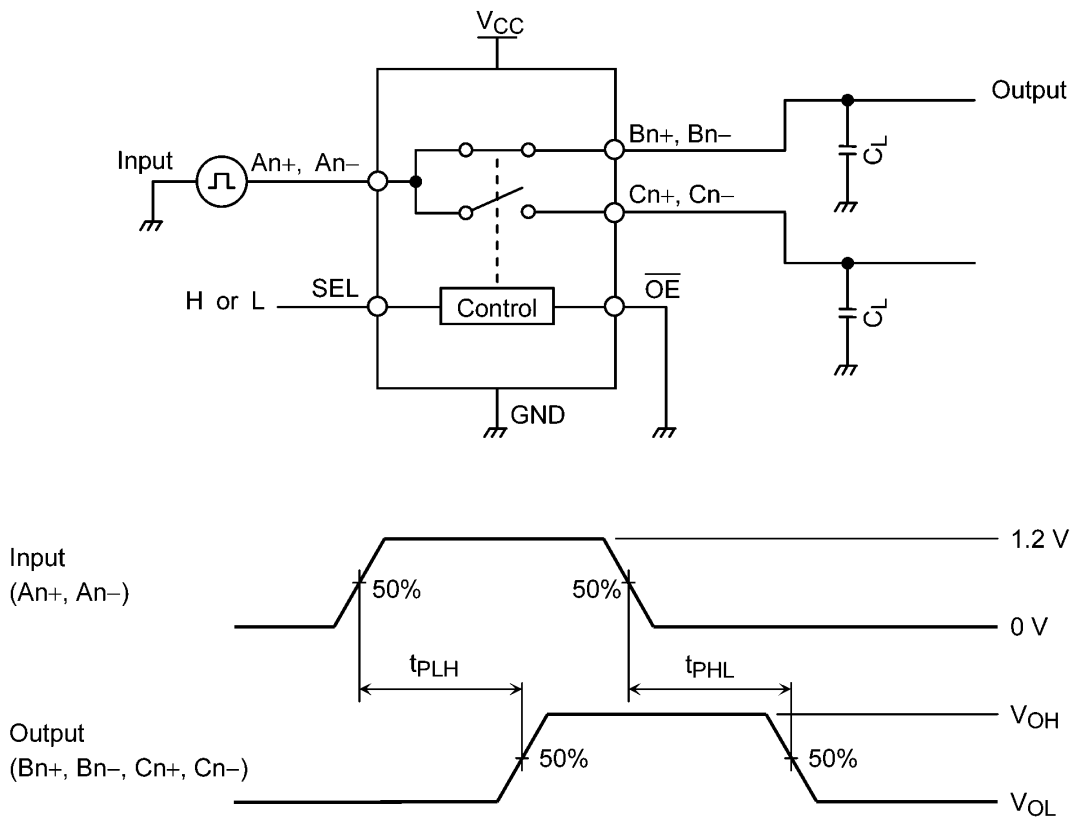

Fig. 12.1 Propagation delay time

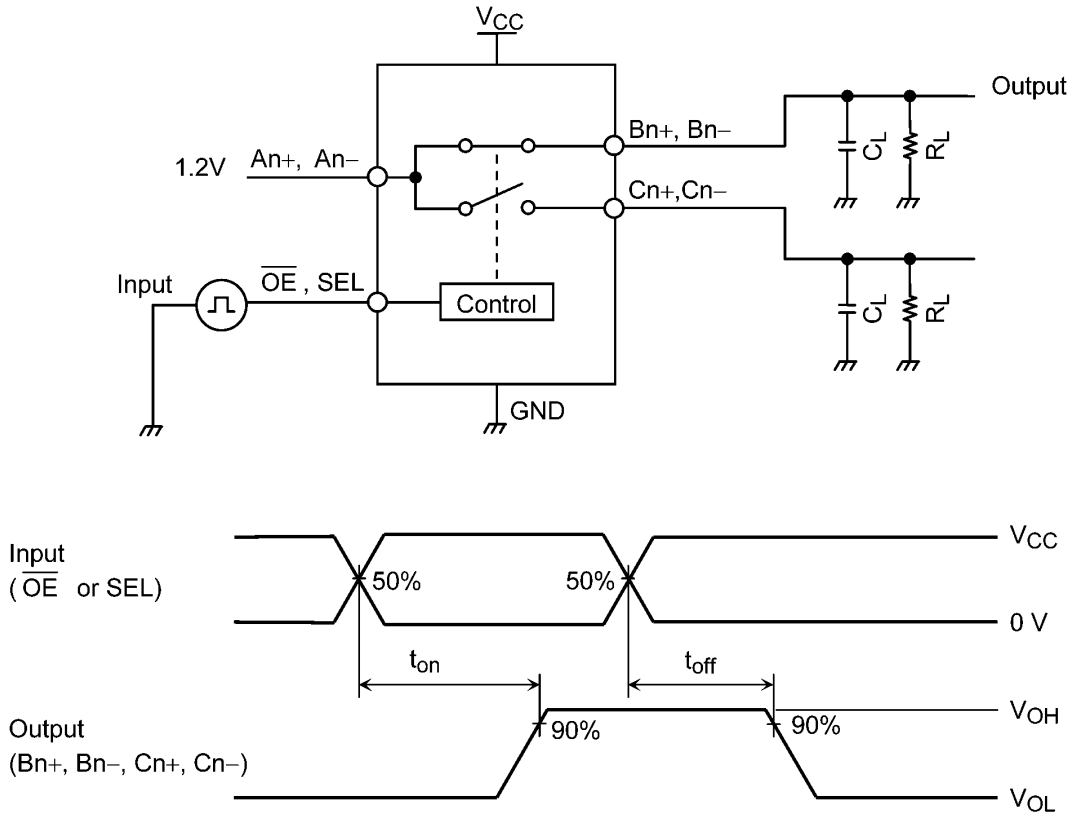

Fig. 12.2 Turn-ON and Turn-OFF time

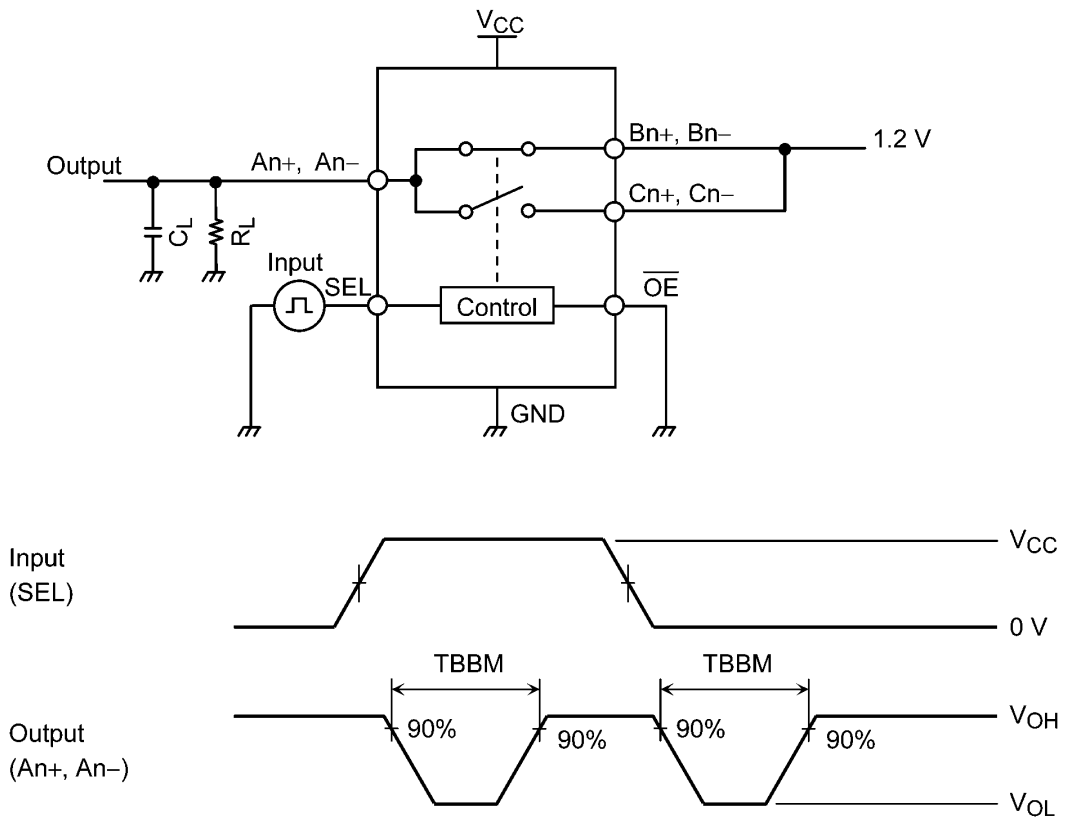

Fig. 12.3 Break before make

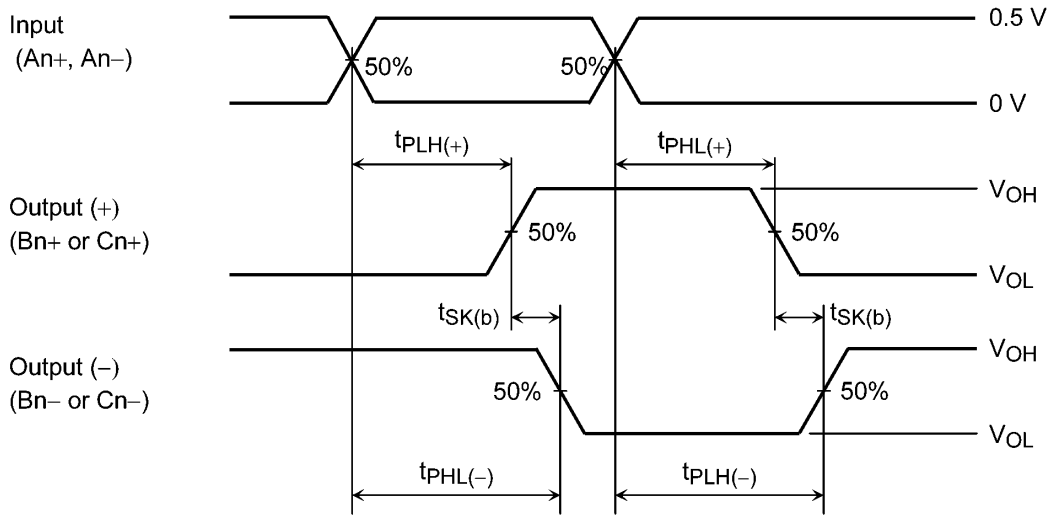
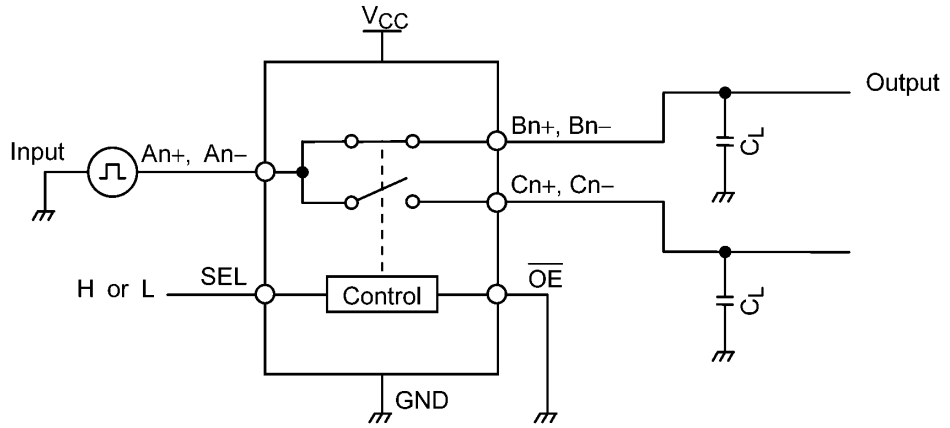

Fig. 12.4 Output skew (bit to bit)

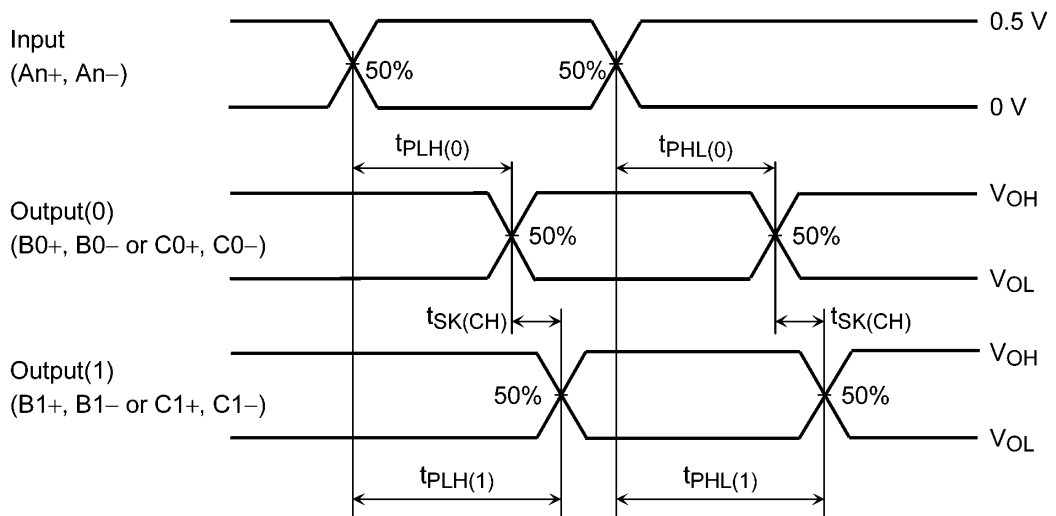
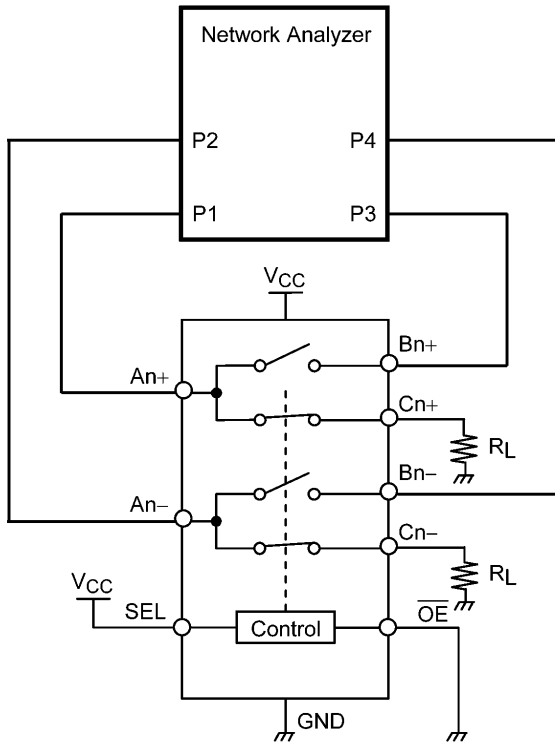
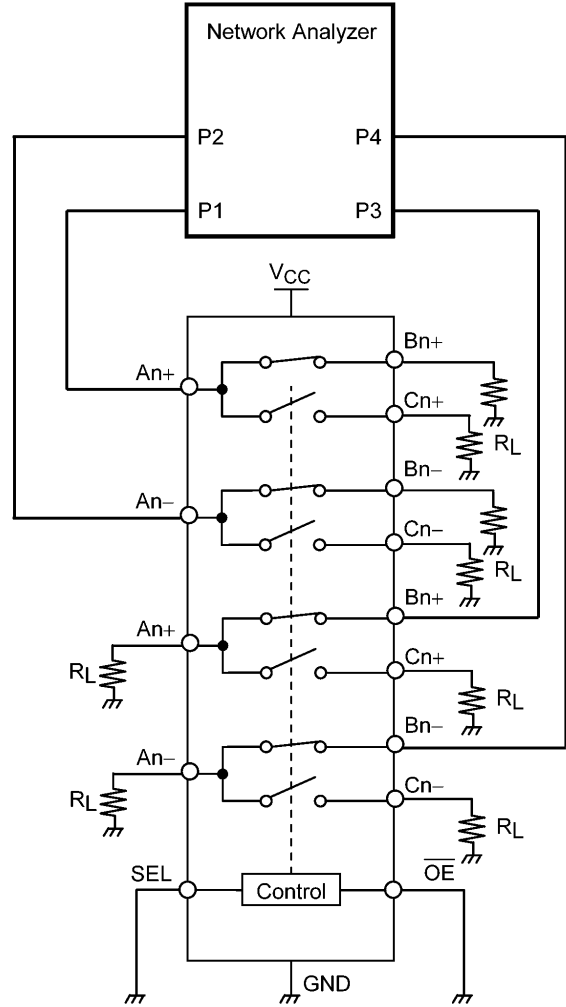

Fig. 12.5 Output skew (channel to channel)



$R_L = 50\ \Omega$
 All unused ports are connected to GND through $50\ \Omega$ pull-down resistors.

Fig. 12.6 Differential OFF isolation



$R_L = 50\ \Omega$
 All unused ports are connected to GND through $50\ \Omega$ pull-down resistors.

Fig. 12.7 Differential Near-end crosstalk

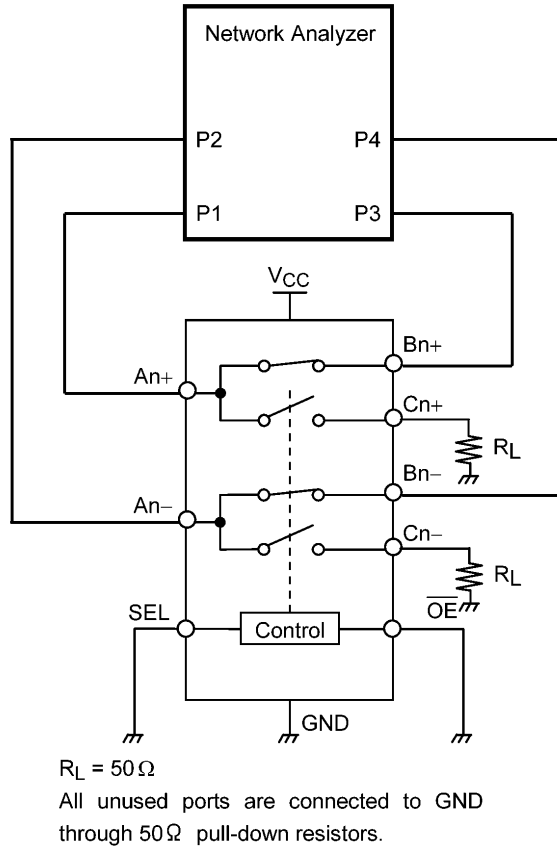
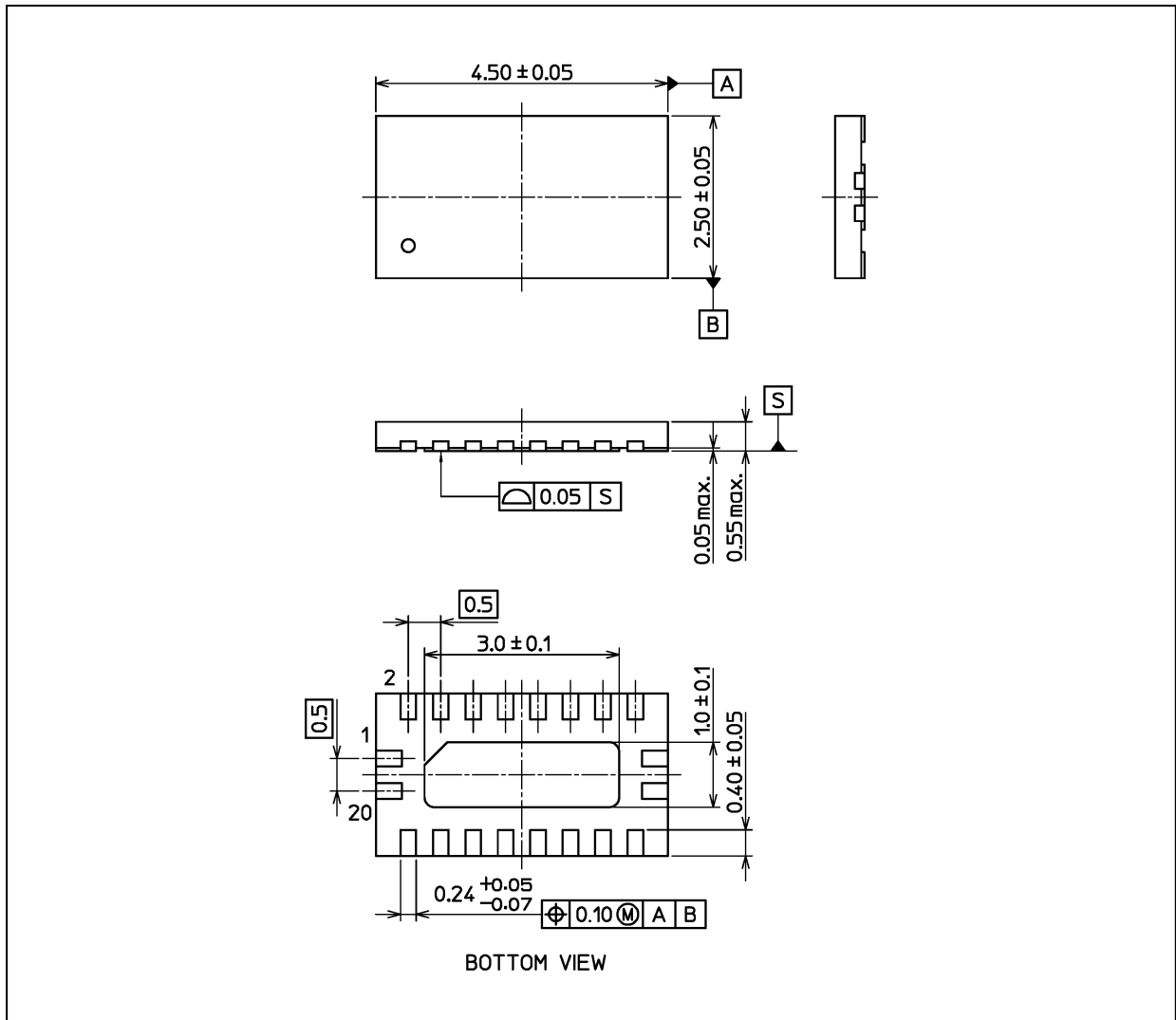

Fig. 12.8 Differential return loss, Differential insertion loss, -3dB Bandwidth

Package Dimensions

Unit: mm



Weight: 0.017 g (typ.)

Package Name(s)
TOSHIBA: P-UQFN20-0305-0.50-001
Nickname: TQFN20

RESTRICTIONS ON PRODUCT USE

- Toshiba Corporation, and its subsidiaries and affiliates (collectively "TOSHIBA"), reserve the right to make changes to the information in this document, and related hardware, software and systems (collectively "Product") without notice.
- This document and any information herein may not be reproduced without prior written permission from TOSHIBA. Even with TOSHIBA's written permission, reproduction is permissible only if reproduction is without alteration/omission.
- Though TOSHIBA works continually to improve Product's quality and reliability, Product can malfunction or fail. Customers are responsible for complying with safety standards and for providing adequate designs and safeguards for their hardware, software and systems which minimize risk and avoid situations in which a malfunction or failure of Product could cause loss of human life, bodily injury or damage to property, including data loss or corruption. Before customers use the Product, create designs including the Product, or incorporate the Product into their own applications, customers must also refer to and comply with (a) the latest versions of all relevant TOSHIBA information, including without limitation, this document, the specifications, the data sheets and application notes for Product and the precautions and conditions set forth in the "TOSHIBA Semiconductor Reliability Handbook" and (b) the instructions for the application with which the Product will be used with or for. Customers are solely responsible for all aspects of their own product design or applications, including but not limited to (a) determining the appropriateness of the use of this Product in such design or applications; (b) evaluating and determining the applicability of any information contained in this document, or in charts, diagrams, programs, algorithms, sample application circuits, or any other referenced documents; and (c) validating all operating parameters for such designs and applications. **TOSHIBA ASSUMES NO LIABILITY FOR CUSTOMERS' PRODUCT DESIGN OR APPLICATIONS.**
- **PRODUCT IS NEITHER INTENDED NOR WARRANTED FOR USE IN EQUIPMENTS OR SYSTEMS THAT REQUIRE EXTRAORDINARILY HIGH LEVELS OF QUALITY AND/OR RELIABILITY, AND/OR A MALFUNCTION OR FAILURE OF WHICH MAY CAUSE LOSS OF HUMAN LIFE, BODILY INJURY, SERIOUS PROPERTY DAMAGE AND/OR SERIOUS PUBLIC IMPACT ("UNINTENDED USE").** Except for specific applications as expressly stated in this document, Unintended Use includes, without limitation, equipment used in nuclear facilities, equipment used in the aerospace industry, medical equipment, equipment used for automobiles, trains, ships and other transportation, traffic signaling equipment, equipment used to control combustions or explosions, safety devices, elevators and escalators, devices related to electric power, and equipment used in finance-related fields. **IF YOU USE PRODUCT FOR UNINTENDED USE, TOSHIBA ASSUMES NO LIABILITY FOR PRODUCT.** For details, please contact your TOSHIBA sales representative.
- Do not disassemble, analyze, reverse-engineer, alter, modify, translate or copy Product, whether in whole or in part.
- Product shall not be used for or incorporated into any products or systems whose manufacture, use, or sale is prohibited under any applicable laws or regulations.
- The information contained herein is presented only as guidance for Product use. No responsibility is assumed by TOSHIBA for any infringement of patents or any other intellectual property rights of third parties that may result from the use of Product. No license to any intellectual property right is granted by this document, whether express or implied, by estoppel or otherwise.
- **ABSENT A WRITTEN SIGNED AGREEMENT, EXCEPT AS PROVIDED IN THE RELEVANT TERMS AND CONDITIONS OF SALE FOR PRODUCT, AND TO THE MAXIMUM EXTENT ALLOWABLE BY LAW, TOSHIBA (1) ASSUMES NO LIABILITY WHATSOEVER, INCLUDING WITHOUT LIMITATION, INDIRECT, CONSEQUENTIAL, SPECIAL, OR INCIDENTAL DAMAGES OR LOSS, INCLUDING WITHOUT LIMITATION, LOSS OF PROFITS, LOSS OF OPPORTUNITIES, BUSINESS INTERRUPTION AND LOSS OF DATA, AND (2) DISCLAIMS ANY AND ALL EXPRESS OR IMPLIED WARRANTIES AND CONDITIONS RELATED TO SALE, USE OF PRODUCT, OR INFORMATION, INCLUDING WARRANTIES OR CONDITIONS OF MERCHANTABILITY, FITNESS FOR A PARTICULAR PURPOSE, ACCURACY OF INFORMATION, OR NONINFRINGEMENT.**
- Do not use or otherwise make available Product or related software or technology for any military purposes, including without limitation, for the design, development, use, stockpiling or manufacturing of nuclear, chemical, or biological weapons or missile technology products (mass destruction weapons). Product and related software and technology may be controlled under the applicable export laws and regulations including, without limitation, the Japanese Foreign Exchange and Foreign Trade Law and the U.S. Export Administration Regulations. Export and re-export of Product or related software or technology are strictly prohibited except in compliance with all applicable export laws and regulations.
- Please contact your TOSHIBA sales representative for details as to environmental matters such as the RoHS compatibility of Product. Please use Product in compliance with all applicable laws and regulations that regulate the inclusion or use of controlled substances, including without limitation, the EU RoHS Directive. **TOSHIBA ASSUMES NO LIABILITY FOR DAMAGES OR LOSSES OCCURRING AS A RESULT OF NONCOMPLIANCE WITH APPLICABLE LAWS AND REGULATIONS.**

X-ON Electronics

Largest Supplier of Electrical and Electronic Components

Click to view similar products for [Multiplexer Switch ICs](#) category:

Click to view products by [Toshiba](#) manufacturer:

Other Similar products are found below :

[NLV74HC4066ADR2G](#) [HEF4051BP](#) [MC74HC4067ADTG](#) [DG508AAK/883B](#) [NLV14051BDG](#) [016400E](#) [PI3V512QE](#) [7705201EC](#)
[PI2SSD3212NCE](#) [NLAS3257CMX2TCG](#) [PI5A3157BC6EX](#) [PI3DBS12412AZLEX](#) [PI3V512QEX](#) [PI3DBS16213ZLEX](#) [PI3DBS16415ZHEX](#)
[PS509LEX](#) [MUX36S16IRSNR](#) [74LVC1G3157GM-Q10X](#) [TC7W53FK,LF](#) [CD4053BM96](#) [MC74HC4053ADWR2G](#) [SN74LV4051APWR](#)
[TC4066BP-NF](#) [HEF4053BT.653](#) [PI3L720ZHEX](#) [ADG5408BRUZ-REEL7](#) [ADG1404YRUZ-REEL7](#) [ADG1208YRZ-REEL7](#)
[PI2DBS6212ZHEX](#) [MAX4704EUB+T](#) [ADG1406BRUZ-REEL7](#) [CD4053BPWRG4](#) [74HC4053D.653](#) [74HCT4052PW.118](#)
[74LVC2G53DP.125](#) [74HC4052DB.112](#) [74HC4052PW.112](#) [74HC4053DB.112](#) [74HC4067DB.112](#) [74HC4351DB.112](#) [74HCT4052D.112](#)
[74HCT4052DB.112](#) [74HCT4053DB.112](#) [74HCT4067D.112](#) [74HCT4351D.112](#) [74LV4051PW.112](#) [FSA1256L8X_F113](#) [PI5V330QE](#)
[PI5V331QE](#) [5962-8771601EA](#)