

# TC7PZ34FU

## 1. Functional Description

- Dual Non-Inverter

## 2. Features

- (1) AEC-Q100 (Rev. H) (Note 1)
- (2) Wide operating temperature range:  $T_{opr} = -40$  to  $125$  °C (Note 2)
- (3) High output current:  $\pm 24$  mA (min) at  $V_{CC} = 3.0$  V
- (4) Super high speed operation:  $t_{pd} = 2.4$  ns (typ.) at  $V_{CC} = 5.0$  V,  $C_L = 50$  pF
- (5) Operation voltage range:  $V_{CC} = 1.65$  to  $5.5$  V
- (6) 5.5 V tolerant inputs
- (7) 5.5 V power down protection output

Note 1: This device is compliant with the reliability requirements of AEC-Q100. For details, contact your Toshiba sales representative.

Note 2: For devices with the ordering part number ending in J(CT).  $T_{opr} = -40$  to  $85$  °C for the other devices.

## 3. Packaging

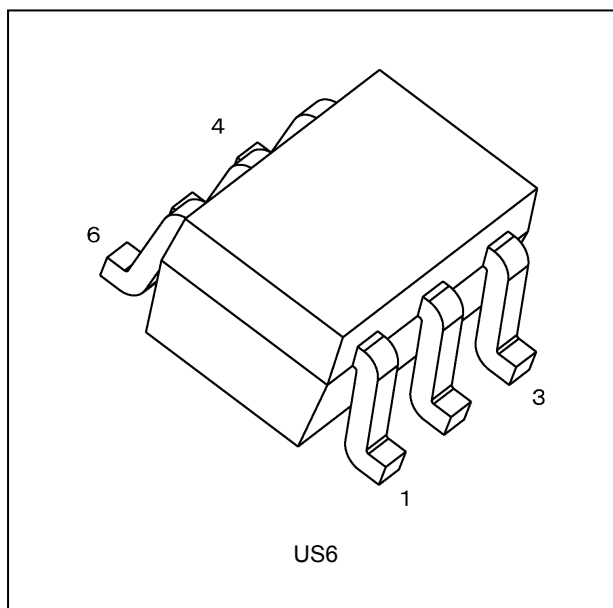

Start of commercial production

2015-09

### 4. Marking and Pin Assignment

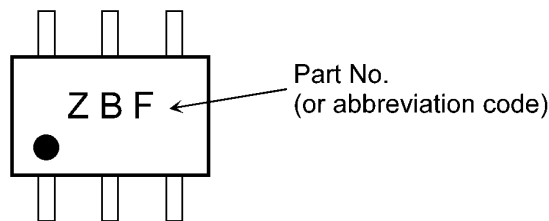

Marking

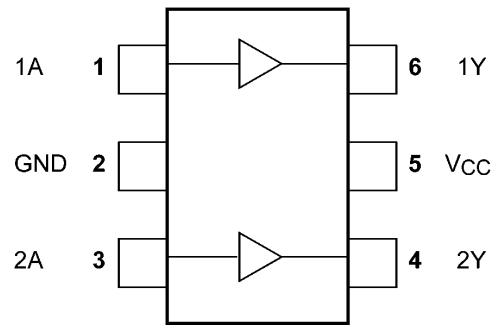

Pin Assignment (Top view)

### 5. IEC Logic Symbol

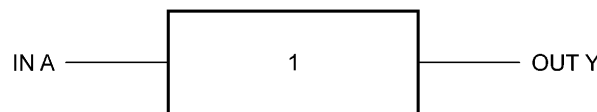

### 6. Truth Table

A	Y
L	L
H	H

### 7. Absolute Maximum Ratings (Note) (Unless otherwise specified, $T_a = 25\text{ }^\circ\text{C}$ )

Characteristics	Symbol	Note	Rating	Unit
Supply voltage	$V_{CC}$		-0.5 to 6.0	V
Input voltage	$V_{IN}$		-0.5 to 6.0	V
DC output voltage	$V_{OUT}$	(Note 1)	-0.5 to 6.0	V
		(Note 2)	-0.5 to $V_{CC} + 0.5$	
Input diode current	$I_{IK}$		-20	mA
Output diode current	$I_{OK}$	(Note 3)	-20	mA
DC output current	$I_{OUT}$		$\pm 50$	mA
$V_{CC}$ /ground current	$I_{CC}$		$\pm 100$	mA
Power dissipation	$P_D$		200	mW
Storage temperature	$T_{stg}$		-65 to 150	$^\circ\text{C}$

Note: Exceeding any of the absolute maximum ratings, even briefly, lead to deterioration in IC performance or even destruction.

Using continuously under heavy loads (e.g. the application of high temperature/current/voltage and the significant change in temperature, etc.) may cause this product to decrease in the reliability significantly even if the operating conditions (i.e. operating temperature/current/voltage, etc.) are within the absolute maximum ratings and the operating ranges.

Please design the appropriate reliability upon reviewing the Toshiba Semiconductor Reliability Handbook ("Handling Precautions"/"Derating Concept and Methods") and individual reliability data (i.e. reliability test report and estimated failure rate, etc).

Note 1:  $V_{CC} = 0\text{ V}$

Note 2: High (H) or Low (L) state.  $I_{OUT}$  absolute maximum rating must be observed.

Note 3:  $V_{OUT} < \text{GND}$

### 8. Operating Ranges (Note)

Characteristics	Symbol	Note	Test Condition	Rating	Unit
Supply voltage	$V_{CC}$		—	1.65 to 5.5	V
		(Note 1)	—	1.5 to 5.5	
Input voltage	$V_{IN}$		—	0 to 5.5	V
Output voltage	$V_{OUT}$	(Note 2)	—	0 to 5.5	V
		(Note 3)	—	0 to $V_{CC}$	
Operating temperature	$T_{opr}$	(Note 4)	—	-40 to 125	°C
		(Note 5)	—	-40 to 85	
Input rise and fall time	dt/dv		$V_{CC} = 1.8 \pm 0.15 \text{ V}, 2.5 \pm 0.2 \text{ V}$	0 to 20	ns/V
			$V_{CC} = 3.3 \pm 0.3 \text{ V}$	0 to 10	
			$V_{CC} = 5.0 \pm 0.5 \text{ V}$	0 to 5	

Note: The operating ranges must be maintained to ensure the normal operation of the device.

Unused inputs must be tied to either  $V_{CC}$  or GND.

Note 1: Data retention only

Note 2:  $V_{CC} = 0 \text{ V}$

Note 3: High (H) or Low (L) state.

Note 4: For devices with the ordering part number ending in J(CT).

Note 5: For devices except those with the ordering part number ending in J(CT).

### 9. Electrical Characteristics

#### 9.1. DC Characteristics (Unless otherwise specified, $T_a = 25\text{ }^\circ\text{C}$ )

Characteristics	Symbol	Test Condition	$V_{CC}$ (V)	Min	Typ.	Max	Unit	
High-level input voltage	$V_{IH}$	—	1.65 to 1.95	$V_{CC} \times 0.75$	—	—	V	
			2.3 to 5.5	$V_{CC} \times 0.7$	—	—		
Low-level input voltage	$V_{IL}$	—	1.65 to 1.95	—	—	$V_{CC} \times 0.25$	V	
			2.3 to 5.5	—	—	$V_{CC} \times 0.3$		
High-level output voltage	$V_{OH}$	$V_{IN} = V_{IH}$	$I_{OH} = -100\text{ }\mu\text{A}$	1.65	1.55	1.65	—	V
				1.8	1.7	1.8	—	
				2.3	2.2	2.3	—	
				3.0	2.9	3.0	—	
				4.5	4.4	4.5	—	
			$I_{OH} = -4\text{ mA}$	1.65	1.29	1.52	—	
			$I_{OH} = -8\text{ mA}$	2.3	1.9	2.15	—	
			$I_{OH} = -16\text{ mA}$	3.0	2.4	2.8	—	
			$I_{OH} = -24\text{ mA}$	3.0	2.3	2.68	—	
$I_{OH} = -32\text{ mA}$	4.5	3.8	4.2	—				
Low-level output voltage	$V_{OL}$	$V_{IN} = V_{IL}$	$I_{OL} = 100\text{ }\mu\text{A}$	1.65	—	0.0	0.1	V
				1.8	—	0.0	0.1	
				2.3	—	0.0	0.1	
				3.0	—	0.0	0.1	
				4.5	—	0.0	0.1	
			$I_{OL} = 4\text{ mA}$	1.65	—	0.08	0.24	
			$I_{OL} = 8\text{ mA}$	2.3	—	0.1	0.3	
			$I_{OL} = 16\text{ mA}$	3.0	—	0.15	0.4	
			$I_{OL} = 24\text{ mA}$	3.0	—	0.22	0.55	
$I_{OL} = 32\text{ mA}$	4.5	—	0.22	0.55				
Input leakage current	$I_{IN}$	$V_{IN} = 5.5\text{ V or GND}$	0 to 5.5	—	—	$\pm 1$	$\mu\text{A}$	
Power-OFF leakage current	$I_{OFF}$	$V_{IN}$ or $V_{OUT} = 5.5\text{ V}$	0	—	—	1	$\mu\text{A}$	
Quiescent supply current	$I_{CC}$	$V_{IN} = V_{CC}$ or GND	5.5	—	—	1	$\mu\text{A}$	

### 9.2. DC Characteristics (Unless otherwise specified, $T_a = -40$ to $85$ °C)

Characteristics	Symbol	Test Condition	$V_{CC}$ (V)	Min	Max	Unit	
High-level input voltage	$V_{IH}$	—	1.65 to 1.95	$V_{CC} \times 0.75$	—	V	
			2.3 to 5.5	$V_{CC} \times 0.7$	—		
Low-level input voltage	$V_{IL}$	—	1.65 to 1.95	—	$V_{CC} \times 0.25$	V	
			2.3 to 5.5	—	$V_{CC} \times 0.3$		
High-level output voltage	$V_{OH}$	$V_{IN} = V_{IH}$	$I_{OH} = -100 \mu A$	1.65	1.55	—	V
				1.8	1.7	—	
				2.3	2.2	—	
				3.0	2.9	—	
				4.5	4.4	—	
			$I_{OH} = -4$ mA	1.65	1.29	—	
			$I_{OH} = -8$ mA	2.3	1.9	—	
			$I_{OH} = -16$ mA	3.0	2.4	—	
			$I_{OH} = -24$ mA	3.0	2.3	—	
			$I_{OH} = -32$ mA	4.5	3.8	—	
Low-level output voltage	$V_{OL}$	$V_{IN} = V_{IL}$	$I_{OL} = 100 \mu A$	1.65	—	0.1	V
				1.8	—	0.1	
				2.3	—	0.1	
				3.0	—	0.1	
				4.5	—	0.1	
			$I_{OL} = 4$ mA	1.65	—	0.24	
			$I_{OL} = 8$ mA	2.3	—	0.3	
			$I_{OL} = 16$ mA	3.0	—	0.4	
			$I_{OL} = 24$ mA	3.0	—	0.55	
			$I_{OL} = 32$ mA	4.5	—	0.55	
Input leakage current	$I_{IN}$	$V_{IN} = 5.5$ V or GND	0 to 5.5	—	$\pm 10$	$\mu A$	
Power-OFF leakage current	$I_{OFF}$	$V_{IN}$ or $V_{OUT} = 5.5$ V	0	—	10	$\mu A$	
Quiescent supply current	$I_{CC}$	$V_{IN} = V_{CC}$ or GND	5.5	—	10	$\mu A$	

### 9.3. DC Characteristics (Note) (Unless otherwise specified, $T_a = -40$ to $125$ °C)

Characteristics	Symbol	Test Condition	$V_{CC}$ (V)	Min	Max	Unit	
High-level input voltage	$V_{IH}$	—	1.65 to 1.95	$V_{CC} \times 0.75$	—	V	
			2.3 to 5.5	$V_{CC} \times 0.7$	—		
Low-level input voltage	$V_{IL}$	—	1.65 to 1.95	—	$V_{CC} \times 0.25$	V	
			2.3 to 5.5	—	$V_{CC} \times 0.3$		
High-level output voltage	$V_{OH}$	$V_{IN} = V_{IH}$	$I_{OH} = -100 \mu A$	1.65	1.55	—	V
				1.8	1.7	—	
				2.3	2.2	—	
				3.0	2.9	—	
				4.5	4.4	—	
			$I_{OH} = -4$ mA	1.65	0.95	—	
			$I_{OH} = -8$ mA	2.3	1.7	—	
			$I_{OH} = -16$ mA	3.0	2.2	—	
			$I_{OH} = -24$ mA	3.0	2.0	—	
			$I_{OH} = -32$ mA	4.5	3.4	—	
Low-level output voltage	$V_{OL}$	$V_{IN} = V_{IL}$	$I_{OL} = 100 \mu A$	1.65	—	0.1	V
				1.8	—	0.1	
				2.3	—	0.1	
				3.0	—	0.1	
				4.5	—	0.1	
			$I_{OL} = 4$ mA	1.65	—	0.7	
			$I_{OL} = 8$ mA	2.3	—	0.45	
			$I_{OL} = 16$ mA	3.0	—	0.6	
			$I_{OL} = 24$ mA	3.0	—	0.8	
			$I_{OL} = 32$ mA	4.5	—	0.8	
Input leakage current	$I_{IN}$	$V_{IN} = 5.5$ V or GND	0 to 5.5	—	$\pm 20$	$\mu A$	
Power-OFF leakage current	$I_{OFF}$	$V_{IN}$ or $V_{OUT} = 5.5$ V	0	—	100	$\mu A$	
Quiescent supply current	$I_{CC}$	$V_{IN} = V_{CC}$ or GND	5.5	—	100	$\mu A$	

Note: For devices with the ordering part number ending in J(CT).

### 9.4. AC Characteristics (Unless otherwise specified, $T_a = 25\text{ }^\circ\text{C}$ , Input: $t_r = t_f = 3\text{ ns}$ )

Characteristics	Symbol	Note	Test Condition	$V_{CC}$ (V)	$C_L$ (pF)	Min	Typ.	Max	Unit
Propagation delay time	$t_{PLH}, t_{PHL}$		$R_L = 1\text{ M}\Omega$	$1.8 \pm 0.15$	15	1.0	4.4	9.5	ns
				$2.5 \pm 0.2$		0.8	2.9	6.5	
				$3.3 \pm 0.3$		0.5	2.1	4.5	
				$5.0 \pm 0.5$		0.5	1.8	3.9	
			$R_L = 500\ \Omega$	$3.3 \pm 0.3$	50	1.5	2.9	5.0	ns
				$5.0 \pm 0.5$		0.8	2.4	4.3	
Input capacitance	$C_{IN}$		—	0 to 5.5	—	—	4	—	pF
Power dissipation capacitance	$C_{PD}$	(Note 1)	—	3.3	—	—	21	—	pF
				5.5		—	34	—	

Note 1:  $C_{PD}$  is defined as the value of the internal equivalent capacitance which is calculated from the operating current consumption without load. Average operating current can be obtained by the equation.

$$I_{CC(opr)} = C_{PD} \cdot V_{CC} \cdot f_{IN} + I_{CC}/2 \text{ (per gate)}$$

### 9.5. AC Characteristics (Unless otherwise specified, $T_a = -40\text{ to }85\text{ }^\circ\text{C}$ , Input: $t_r = t_f = 3\text{ ns}$ )

Characteristics	Symbol	Test Condition	$V_{CC}$ (V)	$C_L$ (pF)	Min	Max	Unit
Propagation delay time	$t_{PLH}, t_{PHL}$	$R_L = 1\text{ M}\Omega$	$1.8 \pm 0.15$	15	1.0	10.0	ns
			$2.5 \pm 0.2$		0.8	7.0	
			$3.3 \pm 0.3$		0.5	4.7	
			$5.0 \pm 0.5$		0.5	4.1	
		$R_L = 500\ \Omega$	$3.3 \pm 0.3$	50	1.5	5.2	ns
			$5.0 \pm 0.5$		0.8	4.5	

### 9.6. AC Characteristics (Note) (Unless otherwise specified, $T_a = -40\text{ to }125\text{ }^\circ\text{C}$ , Input: $t_r = t_f = 3\text{ ns}$ )

Characteristics	Symbol	Test Condition	$V_{CC}$ (V)	$C_L$ (pF)	Min	Max	Unit
Propagation delay time	$t_{PLH}, t_{PHL}$	$R_L = 1\text{ M}\Omega$	$1.8 \pm 0.15$	15	1.0	11.0	ns
			$2.5 \pm 0.2$		0.8	8.0	
			$3.3 \pm 0.3$		0.5	5.5	
			$5.0 \pm 0.5$		0.5	5.0	
		$R_L = 500\ \Omega$	$3.3 \pm 0.3$	50	1.5	6.0	ns
			$5.0 \pm 0.5$		0.8	5.0	

Note: For devices with the ordering part number ending in J(CT).

## Package Dimensions

Unit: mm

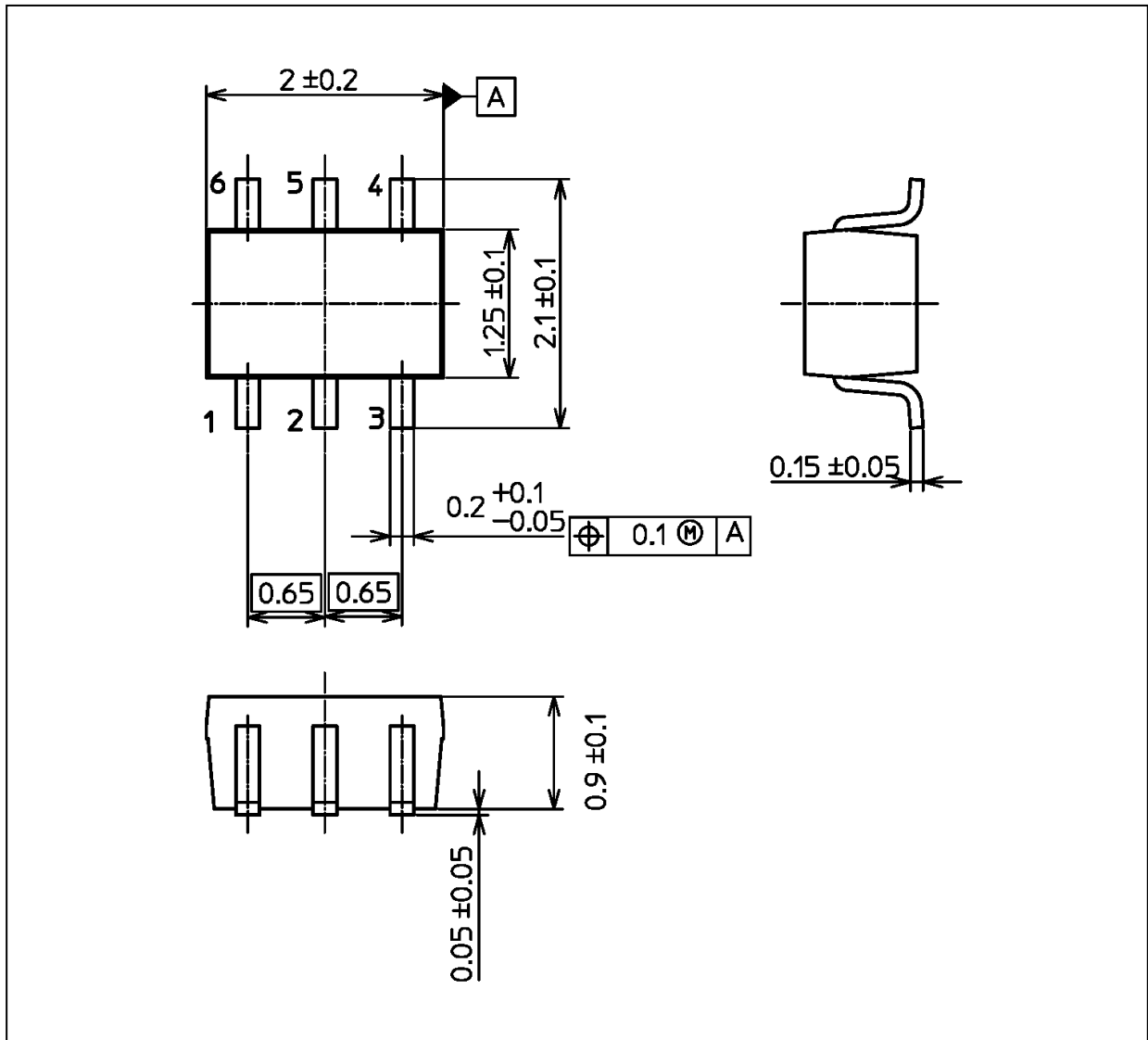

Weight: 0.007 g (typ.)

Package Name(s)
JEDEC: SOT-363
Nickname: US6



## X-ON Electronics

Largest Supplier of Electrical and Electronic Components

*Click to view similar products for [Logic Gates](#) category:*

*Click to view products by [Toshiba](#) manufacturer:*

Other Similar products are found below :

[NL17SG32DFT2G](#) [CD4068BE](#) [NL17SG86DFT2G](#) [NLX1G11AMUTCG](#) [NLX1G97MUTCG](#) [74LS38](#) [74LVC1G08Z-7](#) [CD4025BE](#)  
[NLV17SZ00DFT2G](#) [NLV17SZ126DFT2G](#) [NLV27WZ17DFT2G](#) [NLV74HC02ADR2G](#) [74HC32S14-13](#) [74LS133](#) [74LVC1G32Z-7](#)  
[74LVC1G86Z-7](#) [NLV74HC14ADR2G](#) [NLV74HC20ADR2G](#) [NLVVHC1G09DFT1G](#) [NLX2G86MUTCG](#) [74LVC2G32RA3-7](#)  
[74LVC2G00HD4-7](#) [NL17SG02P5T5G](#) [74LVC2G86HK3-7](#) [NLVVHC1G14DFT2G](#) [NLX1G99DMUTWG](#) [NLVVHC1G00DFT2G](#)  
[NLV7SZ57DFT2G](#) [NLV74VHC04DTR2G](#) [NLV27WZ00USG](#) [NLU1G86CMUTCG](#) [NLU1G08CMUTCG](#) [NL17SZ32P5T5G](#)  
[NL17SZ00P5T5G](#) [NL17SH02P5T5G](#) [74AUP2G00RA3-7](#) [NLVVHC1GT00DFT2G](#) [NLV74HC02ADTR2G](#) [NLX1G332CMUTCG](#)  
[NLVHCT132ADTR2G](#) [NL17SG86P5T5G](#) [NL17SZ05P5T5G](#) [NLV74VHC00DTR2G](#) [NLVVHC1G02DFT1G](#) [NLV74HC86ADR2G](#)  
[74LVC2G32HK3-7](#) [74LVC2G86RA3-7](#) [NL17SZ38DBVT1G](#) [NLV18SZ00DFT2G](#) [NLVVHC1G07DFT1G](#)