

TLP5231

1. Applications

- IGBT Gate Drivers
- MOSFET Gate Drivers
- Industrial Inverters
- AC Servos
- Photovoltaic (PV) Power Conditioning Systems
- Air Conditioner Inverters

2. General

The TLP5231 is a 2.5 A dual-output IGBT gate pre-drive photocoupler including highly integrated multi-functional IC that is housed in SO16L package having a long creepage and clearance. This photocoupler is suitable as a pre-driver to driver power devices via external p- and n- channel MOSFET as buffers.

The smart gate driver photocoupler includes functions of IGBT/power MOSFET desaturation detection, isolated fault status feedback, configurable soft gate turn-off, and under voltage lockout (UVLO).

The TLP5231 consists of two infrared light-emitting diodes (LEDs) and two high-gain and high-speed light-receiving IC chips. Thereby, they realize the control of output current and the feedback function of the fault signal while keeping a insulation between a primary side and secondary side electrically.

3. Features

- (1) Output peak current: ± 2.5 A (max)
- (2) Operating temperature: -40 to 110 °C
- (3) Threshold input current: 3.5 mA (max)
- (4) Propagation delay time: 300 ns (max)
- (5) Common-mode transient immunity: ± 25 kV/ μ s (min)
- (6) Isolation voltage: 5000 Vrms (min)
- (7) Dual output drive for external complementary type MOS buffer.
- (8) Under Voltage Lock-Out protection for positive and negative gate power supply.
- (9) Safety standards

UL-recognized: UL 1577, File No.E67349

cUL-recognized: CSA Component Acceptance Service No.5A File No.E67349

VDE-approved: EN 60747-5-5, EN 62368-1 (**Note 1**)

CQC-approved: GB4943.1, GB8898 Japan Factory

Note 1: When a VDE approved type is needed, please designate the **Option (D4)**.

Start of commercial production
2020-01

4. Packaging and Pin Assignment

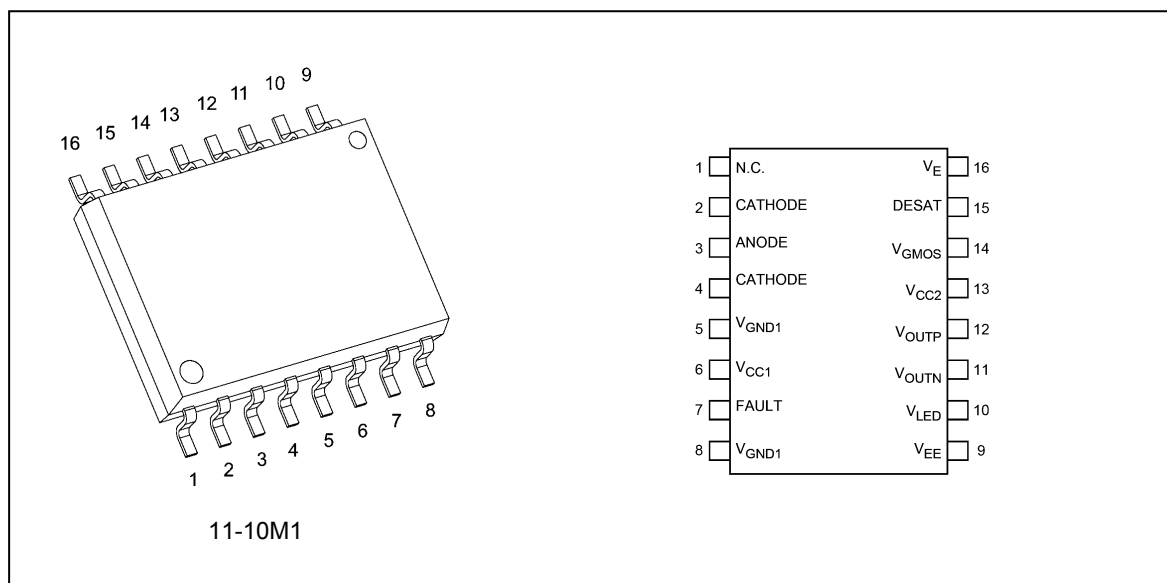

4.1. Pin Description

Pin No.	Symbol	Description
1	N.C.	No connection
2	CATHODE	Cathode
3	ANODE	Anode
4	CATHODE	Cathode
5	V_{GND1}	Input side ground
6	V_{CC1}	Positive input supply voltage
7	FAULT	Fault output
8	V_{GND1}	Input side ground
9	V_{EE}	Negative output supply voltage
10	V_{LED}	Not connect, for testing only
11	V_{OUTN}	Low side voltage output
12	V_{OUTP}	High side voltage output
13	V_{CC2}	Positive output supply voltage
14	V_{GMOS}	External MOSFET control pin
15	DESAT	Short-circuit detection of The Desat terminal
16	V_E	Common output power supply terminal (emitter or source terminal of power device)

5. Internal Circuit (Note)

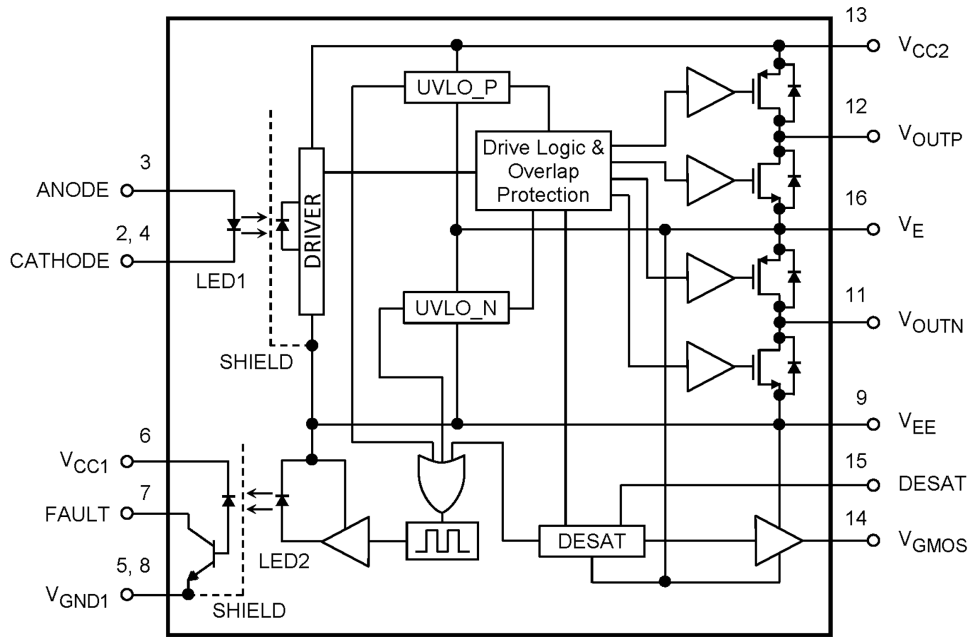

Note: A 10 μ F bypass capacitor must be connected between pins 9 and 13, and A 1 μ F bypass capacitor must be connected between pins 13 and 16, and pins 9 and 16.
A 0.33 μ F bypass capacitor must be connected between pins 6 and 5, or pins 6 and 8.

6. Principle of Operation

6.1. Truth Table

Input current I_F	Under Voltage Lock-Out UVLO_P, UVLO_N	DESAT function	FAULT pin7 OUTPUT	V_{OUTP}	V_{OUTN}	V_{GMOS}
X	Active	Not active	H (V_{CC1})	H (V_{CC2})	H (V_E)	H (V_E)
ON	Not active	Active (with DESAT fault)	H (V_{CC1})	H (V_{CC2})	L (V_{EE})	H (V_E)
ON	Not active	Active (without DESAT fault)	L (V_{GND1})	L (V_E)	L (V_{EE})	L (V_{EE})
OFF	Not active	Not active	L (V_{GND1})	H (V_{CC2})	H (V_E)	L (V_{EE})

6.2. Mechanical Parameters

Characteristics	Dimensions	Unit
Creepage distances	8.0 (min)	mm
Clearance distances		
Internal isolation thickness	0.4 (min)	

7. Absolute Maximum Ratings (Note) (Unless otherwise specified, $T_a = 25\text{ }^\circ\text{C}$)

	Characteristics	Symbol	Note	Rating	Unit
LED (controller side)	Input forward current	I_F		25	mA
	Input forward current derating ($T_a \geq 95\text{ }^\circ\text{C}$)	$\Delta I_F/\Delta T_a$		-0.84	mA/ $^\circ\text{C}$
	Peak transient input forward current	I_{FPT}	(Note 1)	1	A
	Peak transient input forward current derating ($T_a \geq 95\text{ }^\circ\text{C}$)	$\Delta I_{FPT}/\Delta T_a$	(Note 2)	-34	mA/ $^\circ\text{C}$
	Input reverse voltage	V_R		5	V
	Positive input supply voltage	V_{CC1}		-0.5 to 7	V
	FAULT output current	I_{FAULT}		8	mA
	FAULT terminal voltage	V_{FAULT}		-0.5 to V_{CC1}	V
	Input power dissipation	P_D		150	mW
	Input power dissipation derating ($T_a \geq 95\text{ }^\circ\text{C}$)	$\Delta P_D/\Delta T_a$	(Note 2)	-5.0	mW/ $^\circ\text{C}$
Detector (gate driver side)	Peak high-level output current ($T_a = -40$ to $110\text{ }^\circ\text{C}$)	I_{OPH}	(Note 3)	-2.5	A
	Peak low-level output current ($T_a = -40$ to $110\text{ }^\circ\text{C}$)	I_{OPL}	(Note 3)	+2.5	A
	Total output supply voltage	$(V_{CC2}-V_{EE})$	(Note 4)	-0.5 to 35	V
	Negative output supply voltage	(V_E-V_{EE})	(Note 4)	-0.5 to 17	V
	Positive output supply voltage	$(V_{CC2}-V_E)$	(Note 4)	-0.5 to 30	V
	High side output voltage	$V_{OUTP(Peak)}$		$V_E - 0.5$ to $V_{CC2} + 0.5$	V
	Low side output voltage	$V_{OUTN(Peak)}$		$V_{EE} - 0.5$ to $V_E + 0.5$	V
	DESAT voltage	V_{DESAT}		$V_E - 0.5$ to $V_{CC2} + 0.5$	V
	V_{GMOS} voltage	V_{GMOS}		$V_{EE} - 0.5$ to $V_E + 0.5$	V
	Output power dissipation	P_O		410	mW
	Output power dissipation derating ($T_a \geq 95\text{ }^\circ\text{C}$)	$\Delta P_O/\Delta T_a$	(Note 2)	-14.0	mW/ $^\circ\text{C}$
Common	Operating temperature	T_{opr}		-40 to 110	$^\circ\text{C}$
	Storage temperature	T_{stg}		-55 to 125	$^\circ\text{C}$
	Lead soldering temperature (10 s)	T_{sol}	(Note 5)	260	$^\circ\text{C}$
	Isolation voltage (AC, 60 s, R.H. $\leq 60\%$)	BV_S	(Note 6)	5000	Vrms

Note: Using continuously under heavy loads (e.g. the application of high temperature/current/voltage and the significant change in temperature, etc.) may cause this product to decrease in the reliability significantly even if the operating conditions (i.e. operating temperature/current/voltage, etc.) are within the absolute maximum ratings.

Please design the appropriate reliability upon reviewing the Toshiba Semiconductor Reliability Handbook ("Handling Precautions"/"Derating Concept and Methods") and individual reliability data (i.e. reliability test report and estimated failure rate, etc.).

Note 1: Pulse width (PW) $\leq 1\mu\text{s}$, 300pps

Note 2: Mounting on the substrate made in accordance with JEDEC JESD51-7.

Note 3: Exponential waveform. Pulse width $\leq 0.2\mu\text{s}$, $f \leq 15\text{ kHz}$, $V_{CC2} = 15\text{ V}$

Note 4: Positive and Negative power supply (V_{CC2}/V_{EE}) must be used in the gate drive circuit.

Note 5: $\geq 2\text{ mm}$ below seating plane.

Note 6: This device is considered as a two-terminal device: Pins 1 through 8 are shorted together, and pins 9 through 16 are shorted together.

8. Recommended Operating Conditions (Note)

Characteristics	Symbol	Note	Min	Typ.	Max	Unit
Total output supply voltage	$(V_{CC2}-V_{EE})$	(Note 1)	21.5	—	30	V
Negative output supply voltage	(V_E-V_{EE})	(Note 1)	-15	—	-6.5	V
Positive output supply voltage	$(V_{CC2}-V_E)$	(Note 1)	15	—	$30 - (V_E - V_{EE})$	V
Positive input supply voltage	V_{CC1}		3.3	—	5.5	V
Input on-state current	$I_{F(ON)}$	(Note 2)	5.3	—	12	mA
Input off-state voltage	$V_{F(OFF)}$	(Note 2)	0	—	0.8	V

Note: The recommended operating conditions are given as a design guide necessary to obtain the intended performance of the device. Each parameter is an independent value. When creating a system design using this device, the electrical characteristics specified in this data sheet should also be considered.

Note: A ceramic capacitor (10 μ F) must be connected between pins 9 (V_{EE}) and 13 (V_{CC2}), and a ceramic capacitor (1 μ F) must be connected between pins 13 (V_{CC2}) and 16 (V_E), and pins 9 (V_{EE}) and 16 (V_E) to stabilize the operation of the high gain linear amplifier. Failure to provide the bypassing may impair the switching property. The bypass capacitor should be placed within 1 cm of each pin.

Note 1: If the rising slopes of V_{CC2} and V_{EE} are so steep, the internal circuit operation may not be stable. In that case please design the slopes that V_{CC2} and V_{EE} go up to become 0.1 V/ μ s or less.

Note 2: The rise and fall times of the input on-current should be less than 0.5 μ s.

9. Electrical Characteristics

9.1. Electrical Characteristics (Note)

(Unless otherwise specified, $T_a = -40$ to 110 °C, $V_{CC2} - V_E = 15$ V, $V_E - V_{EE} = 8$ V)

Characteristics	Symbol	Note	Test Circuit	Test Condition	Min	Typ.	Max	Unit
Input forward voltage	V_F			$I_F = 10$ mA, $T_a = 25$ °C	1.45	—	1.7	V
Input reverse current	I_R			$V_R = 5$ V	—	—	10	μA
Input capacitance	C_t			$V = 0$ V, $f = 1$ MHz, $T_a = 25$ °C	—	60	—	pF
FAULT low level output voltage	V_{FAULTL}			$V_{DESAT} = 0$ V, $R_F = 10$ kΩ, $C_F = 1$ nF, $V_{CC1} = 3.3$ or 5 V	—	0.1	0.25	V
FAULT high level output voltage	V_{FAULTH}			$V_{DESAT} = \text{Open}$, $R_F = 10$ kΩ, $C_F = 1$ nF, $V_{CC1} = 3.3$ or 5 V	—	V_{CC1}	—	V
FAULT low level output current	I_{FAULTL}			$V_{FAULT} = 0.15$ V, $V_{CC1} = 3.3$ or 5 V	—	1.2	—	mA
FAULT high level output current	I_{FAULTH}			$V_{FAULT} = V_{CC1} = 3.3$ or 5 V	—	0.01	1	μA
V_{OUTP} high level output current	I_{OUTPH}	(Note 1)	Fig.13.1.1	$V_{CC2} - V_{OUTP} = 7$ V	—	—	-1.0	A
V_{OUTP} low level output current	I_{OUTPL}	(Note 1)	Fig.13.1.2	$V_{OUTP} - V_E = 7$ V, $I_F = 8$ mA	1.0	—	—	A
V_{OUTN} high level output current	I_{OUTNH}	(Note 1)	Fig.13.1.3	$V_E - V_{OUTN} = 7$ V	—	—	-1.0	A
V_{OUTN} low level output current	I_{OUTNL}	(Note 1)	Fig.13.1.4	$V_{OUTN} - V_{EE} = 7$ V, $I_F = 8$ mA	1.0	—	—	A
V_{OUTP} high level output resistance	R_{OUTPH}	(Note 1)	Fig.13.1.5	$I_{OUTP} = -1.0$ A, $V_F = 0$ V	—	1.6	4.4	Ω
V_{OUTP} low level output resistance	R_{OUTPL}	(Note 1)	Fig.13.1.6	$I_{OUTP} = 1.0$ A, $I_F = 8$ mA	—	1.2	3.3	Ω
V_{OUTN} high level output resistance	R_{OUTNH}	(Note 1)	Fig.13.1.7	$I_{OUTN} = -1.0$ A, $V_F = 0$ V	—	1.9	5.0	Ω
V_{OUTN} low level output resistance	R_{OUTNL}	(Note 1)	Fig.13.1.8	$I_{OUTN} = 1.0$ A, $I_F = 8$ mA	—	1.0	3.3	Ω
V_{OUTP} high level output voltage	V_{OUTPH}		Fig.13.1.5	$I_{OUTP} = -100$ mA, $V_F = 0$ V	$V_{CC2} - 0.43$	$V_{CC2} - 0.14$	—	V
V_{OUTP} low level output voltage	V_{OUTPL}		Fig.13.1.6	$I_{OUTP} = 100$ mA, $I_F = 8$ mA	—	$V_E + 0.1$	$V_E + 0.32$	V
V_{OUTN} high level output voltage	V_{OUTNH}		Fig.13.1.7	$I_{OUTN} = -100$ mA, $V_F = 0$ V	$V_E - 0.4$	$V_E - 0.17$	—	V
V_{OUTN} low level output voltage	V_{OUTNL}		Fig.13.1.8	$I_{OUTN} = 100$ mA, $I_F = 8$ mA	—	$V_{EE} + 0.1$	$V_{EE} + 0.3$	V

Note: All typical values are at $T_a = 25$ °C.

Note: C_F means smoothing capacitor. It attaches between pin 7 and pin 5, or pin 7 and pin 8 certainly.

Note 1: I_O application time ≤ 10 μs; single pulse.

9.2. Electrical Characteristics (Note) (Unless otherwise specified, $T_a = -40$ to 110 °C, $V_{CC2} - V_E = 15$ V, $V_E - V_{EE} = 8$ V)

Characteristics	Symbol	Note	Test Circuit	Test Condition	Min	Typ.	Max	Unit
V_{GMOS} high level output current	I_{OUTGH}		Fig.13.1.9	$V_E - V_{GMOS} = 8$ V, $I_F = 8$ mA, DESAT = Open	—	—	-105	mA
V_{GMOS} low level output current	I_{OUTGL}		Fig.13.1.10	$V_{GMOS} - V_{EE} = 8$ V, $V_F = 0$ V, DESAT = Open	90	—	—	
V_{GMOS} high level output resistance	R_{OUTGH}		Fig.13.1.11	$I_{OUTG} = -80$ mA, $I_F = 8$ mA	—	10	30	Ω
V_{GMOS} low level output resistance	R_{OUTGL}		Fig.13.1.12	$I_{OUTG} = 80$ mA, $V_F = 0$ V, DESAT = Open	—	4	10	
V_{GMOS} high level output voltage	V_{OUTGH}		Fig.13.1.11	$I_{OUTG} = -1$ mA, $I_F = 8$ mA, DESAT = Open	—	V_E	—	V
V_{GMOS} low level output voltage	V_{OUTGL}		Fig.13.1.12	$I_{OUTG} = 1$ mA, $V_F = 0$ V, DESAT = Open	—	V_{EE}	—	
High level supply current (V_{CC2})	I_{CC2H}		Fig.13.1.13	$V_F = 0$ V, no load	—	5.8	10.2	mA
Low level supply current (V_{CC2})	I_{CC2L}		Fig.13.1.14	$I_F = 8$ mA, no load	—	6.2	10.2	
High level supply current (V_{EE})	I_{EEH}		Fig.13.1.13	$V_F = 0$ V, no load	-9.2	-5.2	—	
Low level supply current (V_{EE})	I_{EEL}		Fig.13.1.14	$I_F = 8$ mA, no load	-9.2	-5.5	—	
Threshold input current (H/L)	I_{FHL}		Fig.13.1.15	$V_{OUTP} - V_E < 5$ V, $V_{OUTN} - V_{EE} < 1$ V	—	1	3.5	
Threshold input voltage (L/H)	V_{FLH}			$V_{OUTP} - V_E > 5$ V, $V_{OUTN} - V_{EE} > 1$ V	0.8	—	—	V
UVLO_P threshold ($V_{CC2}-V_E$)	V_{UVLOP+}	(Note 1), (Note 2)		$I_F = 8$ mA, $V_{OUTP} - V_E < 5$ V	12	13	14	
UVLO_P threshold ($V_{CC2}-V_E$)	V_{UVLOP-}	(Note 1)		$I_F = 8$ mA, $V_{OUTP} - V_E > 5$ V	11	12	13	
UVLO_P hysteresis ($V_{CC2}-V_E$)	V_{UVLOP_HYS}	(Note 1)		$V_{UVLOP+} - V_{UVLOP-}$	—	1	—	
UVLO_N threshold (V_E-V_{EE})	V_{UVLON+}	(Note 1), (Note 2)		$I_F = 8$ mA, $V_{OUTN} - V_{EE} < 1$ V	-6	-5.3	-5	
UVLO_N threshold (V_E-V_{EE})	V_{UVLON-}	(Note 1)		$I_F = 8$ mA, $V_{OUTN} - V_{EE} > 1$ V	-5.7	-5.0	-4.7	
UVLO_N hysteresis (V_E-V_{EE})	V_{UVLON_HYS}	(Note 1)		$V_{UVLON+} - V_{UVLON-}$	—	0.3	—	
DESAT threshold	V_{DESAT}	(Note 2)		$V_{CC2} - V_E > V_{UVLOP+}$, $V_E - V_{EE} > V_{UVLON-}$	7.5	8.0	9.0	
Blanking capacitor charging current	I_{CHG}		Fig.13.1.16	$V_{DESAT} = 2$ V	-0.82	-0.54	-0.29	mA
Blanking capacitor discharging voltage	V_{DSCHG}			$I_{DSCHG} = 10$ mA	—	1.1	3.0	V

Note: All typical values are at $T_a = 25$ °C.

Note 1: V_{UVLOP+} is the increasing of $V_{CC2}-V_E$. V_{UVLOP-} is the decreasing of $V_{CC2}-V_E$.

15V is the recommended minimum V_{CC2} to ensure adequate margin in excess of the maximum V_{UVLOP+} .

V_{UVLON+} is the increasing of V_E-V_{EE} . V_{UVLON-} is the decreasing of V_E-V_{EE} .

-6.5V is the recommended maximum V_{EE} to ensure adequate margin in excess of the minimum V_{UVLON+} .

Note 2 : Once V_{OUTP} and V_{OUTN} are allowed to go low, the DESAT detection feature will be the primary source of power device protection.

In order for to DESAT function, un-activating of UVLO is required. ($V_{CC2}-V_E > V_{UVLOP+}$, $V_E-V_{EE} > V_{UVLON-}$)

10. Isolation Characteristics (Unless otherwise specified, $T_a = 25\text{ °C}$)

Characteristics	Symbol	Note	Test Condition	Min	Typ.	Max	Unit
Total capacitance (input to output)	C_S	(Note 1)	$V_S = 0\text{ V}$, $f = 1\text{ MHz}$	—	1.0	—	pF
Isolation resistance	R_S	(Note 1)	$V_S = 500\text{ V}$, R.H. $\leq 60\%$	10^{12}	10^{14}	—	Ω
Isolation voltage	BV_S	(Note 1)	AC, 60 s	5000	—	—	Vrms

Note 1: This device is considered as a two-terminal device: Pins 1 through 8 are shorted together, and pins 9 through 16 are shorted together.

11. Switching Characteristics

11.1. Switching Characteristics (Note)

(Unless otherwise specified, $T_a = -40$ to 110 °C, $V_{CC2} - V_E = 15$ V, $V_E - V_{EE} = 8$ V)

Characteristics	Symbol	Note	Test Circuit	Test Condition	Min	Typ.	Max	Unit	
Propagation delay time (L/H)	t_{pLH}	(Note 1)	Fig.13.1.17	$I_F = 8 \rightarrow 0$ mA, $C_P = C_N = 4$ nF, $f = 20$ kHz, duty = 50 %	100	200	300	ns	
Propagation delay time (H/L)	t_{pHL}			$I_F = 0 \rightarrow 8$ mA, $C_P = C_N = 4$ nF, $f = 20$ kHz, duty = 50 %	100	200	300		
Pulse width distortion	$ \frac{t_{pHL}}{t_{pLH}} - \frac{t_{pLH}}{t_{pHL}} $			$I_F = 0 \leftrightarrow 8$ mA, $C_P = C_N = 4$ nF, $f = 20$ kHz, duty = 50 %	—	—	150		
Propagation delay skew (device to device)	t_{psk}	(Note 1), (Note 2)				-200	—		200
V_{OUTP} rise time at LED-OFF (90 %)	t_{DP}	(Note 1)			$I_F = 8 \rightarrow 0$ mA, $C_P = C_N = 4$ nF, $f = 20$ kHz, duty = 50 %	50	150		250
V_{OUTN} fall time at LED-ON (10%)	t_{DN}			$I_F = 0 \rightarrow 8$ mA, $C_P = C_N = 4$ nF, $f = 20$ kHz, duty = 50 %	50	150	250		
Outputs non-overlap time (L/H)	t_{NLH}				$I_F = 8 \rightarrow 0$ mA, $C_P = C_N = 4$ nF, $f = 20$ kHz, duty = 50 %	—	60		—
Outputs non-overlap time (H/L)	t_{NHL}				$I_F = 0 \rightarrow 8$ mA, $C_P = C_N = 4$ nF, $f = 20$ kHz, duty = 50 %	—	50		—
Rise time of V_{OUTP}	t_{PR}				$I_F = 8 \rightarrow 0$ mA, $C_P = C_N = 4$ nF, $f = 20$ kHz, duty = 50 %	—	50		—
Fall time of V_{OUTP}	t_{PF}				$I_F = 0 \rightarrow 8$ mA, $C_P = C_N = 4$ nF, $f = 20$ kHz, duty = 50 %	—	50		—
Rise time of V_{OUTN}	t_{NR}				$I_F = 8 \rightarrow 0$ mA, $C_P = C_N = 4$ nF, $f = 20$ kHz, duty = 50 %	—	50		—
Fall time of V_{OUTN}	t_{NF}				$I_F = 0 \rightarrow 8$ mA, $C_P = C_N = 4$ nF, $f = 20$ kHz, duty = 50 %	—	40		—

Note: All typical values are at $T_a = 25$ °C.

C_P and C_N mean the gate capacitance of an external MOSFET buffer.

Note 1: Input signal duty = 50 %, $t_r = t_f = 5$ ns or less

Note 2: The propagation delay skew, t_{psk} , is equal to the magnitude of the worst-case difference in t_{pHL} and/or t_{pLH} that will be seen between units at the same given conditions (supply voltage, input current, temperature, etc).

11.2. Switching Characteristics (Note)

(Unless otherwise specified, $T_a = -40$ to 110 °C, $V_{CC2} - V_E = 15$ V, $V_E - V_{EE} = 8$ V)

Characteristics	Symbol	Note	Test Circuit	Test Condition	Min	Typ.	Max	Unit
Propagation delay time from DESAT threshold to 50% of high V_{GMOS}	t_1	(Note 1)	Fig.13.1.18	$C_P = C_N = 4$ nF, $C_G = 1$ nF, $f = 100$ Hz, duty = 50 %, $I_F = 8$ mA, $C_{BLANK} = 200$ pF, $V_{DESAT} = 8.0$ V	—	450	750	ns
Propagation delay time from DESAT threshold to 50% of high V_{OUTP}	t_2				—	380	700	
Propagation delay time from DESAT threshold to 50% of high V_{FAULT}	t_3			$R_F = 10$ k Ω , $C_F = 1$ nF, $V_{CC1} = 3.3$ or 5 V, $f = 100$ Hz, duty = 50 %, $I_F = 8$ mA	—	8	20	μ s
Propagation delay time from 50% V_{GMOS} to 50% of V_{OUTN}	t_4			$C_P = C_N = 4$ nF, $C_G = 1$ nF, $f = 100$ Hz, duty = 50 %, $I_F = 8$ mA	—	45	—	ns
DESAT Mute time	t_{MUTE}	(Note 2)		$I_F = 8$ mA	0.68	1.1	1.7	ms
DESAT leading edge blanking time	$t_{DESAT(L\text{EB})}$	(Note 3)		—	—	580	—	ns
DESAT filter time	$t_{DESAT(FILTER)}$	(Note 4)		$R_{DESAT} = 100$ Ω , $V_{in} = 10$ V, $PW = 1$ μ s, monitor: V_{OUTP} , V_{GMOS}	—	290	—	
High-level common-mode transient immunity	CM_H	(Note 5)	Fig.13.1.19, Fig.13.1.21	$T_a = 25$ °C, $ V_{CM} = 1500$ V _{p-p} , $V_{CC1} = 5$ V ($I_F = 0$ mA), $R_{in} = 220$ Ω (with split resistors)	± 25	—	—	kV/ μ s
Low-level common-mode transient immunity	CM_L	(Note 6)	Fig.13.1.20, Fig.13.1.22	$T_a = 25$ °C, $ V_{CM} = 1500$ V _{p-p} , $V_{CC1} = 5$ V ($I_F = 8$ mA), $R_{in} = 220$ Ω (with split resistors)	± 25	—	—	

Note: All typical values are at $T_a = 25$ °C.

C_G means the external MOSFET gate capacitance for soft gate turn-off.

Note 1: Input signal duty = 50 %, $t_r = t_f = 5$ ns or less

Note 2: Automatic reset time from protected operation. If the input voltage of a DESAT pin exceeds V_{DESAT} , V_{OUTP} moves to high level, V_{OUTN} set to low level, V_{GMOS} moves to high level and FAULT moves to high level, then protected operation will start. If a gate input signal returns to a low level, automatic reset of the protected operation will be carried out after t_{MUTE} . Refer to Fig. 13.2.2 and Fig. 13.2.3.

Note 3: Disabling time for incorrect detection prevention in case a gate control signal inputs. Refer to Fig. 13.2.2.

Note 4: Disabling time for incorrect detection prevention when the input voltage to a DESAT pin exceeds V_{DESAT} . ($t_{DESAT(FILTER)} < t_1, t_2$)

Note 5: CM_H is the maximum rate of fall of the common mode voltage that can sustained with the output voltage in the logic high state ($V_{OUTP} - V_E > 12$ V, $V_{OUTN} - V_{EE} > 5$ V or $V_{FAULT} > 2$ V).

Note 6: CM_L is the maximum rate of rise of the common mode voltage that can sustained with the output voltage in the logic low state ($V_{OUTP} - V_E < 1$ V, $V_{OUTN} - V_{EE} < 1$ V or $V_{FAULT} < 0.8$ V).

12. Application Information

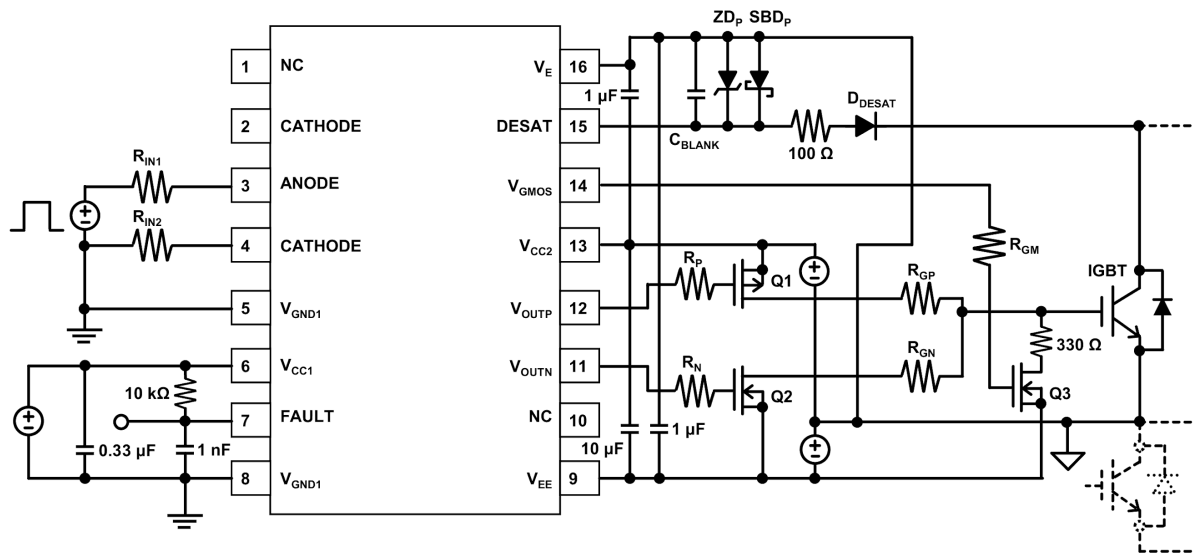

Fig. 12.1 Recommended Application Circuit

Note: The gate circuit of a power device requires both a positive power supply (V_{CC2}) and a negative power supply (V_{EE}).

Attach external P channel MOSFET and N channel MOSFET to a V_{OUTP} pin and a V_{OUTN} pin.

Refer to the connection of pin 14, pin 15, and pin 16 for a DESAT detection function and an over-current protection soft gate turn-off function.

A smoothing capacitor is absolutely attached between pin 7 and pin 5, or pin 7 and pin 8.

13. Reference Drawings

13.1. Test Circuits

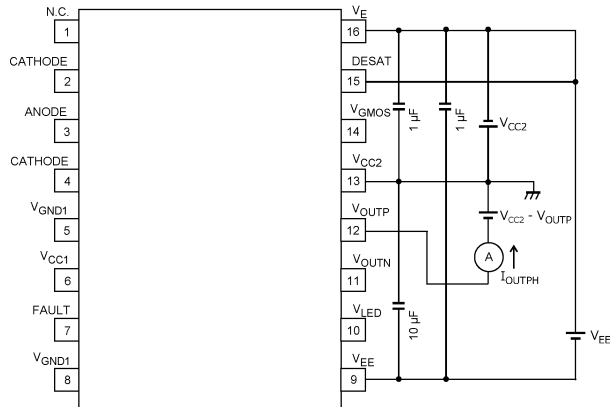

Fig. 13.1.1 I_{OUTPH} Test Circuit

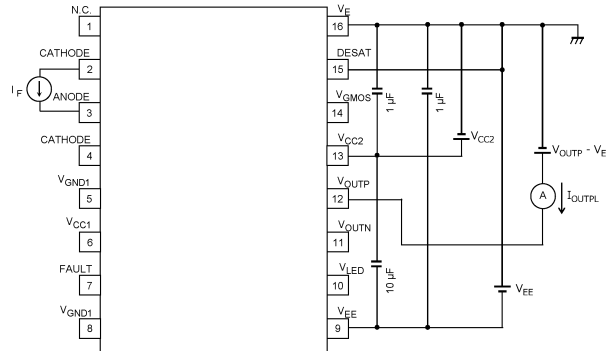

Fig. 13.1.2 I_{OUTPL} Test Circuit

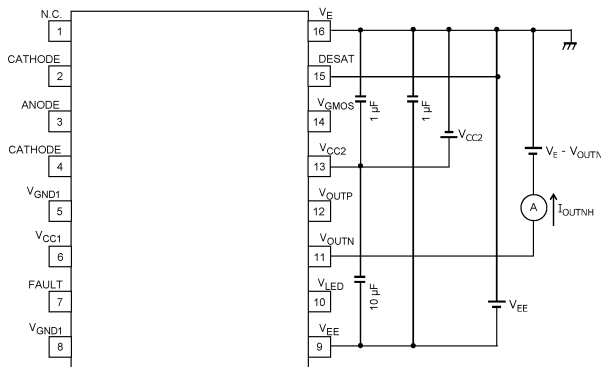

Fig. 13.1.3 I_{OUTNH} Test Circuit

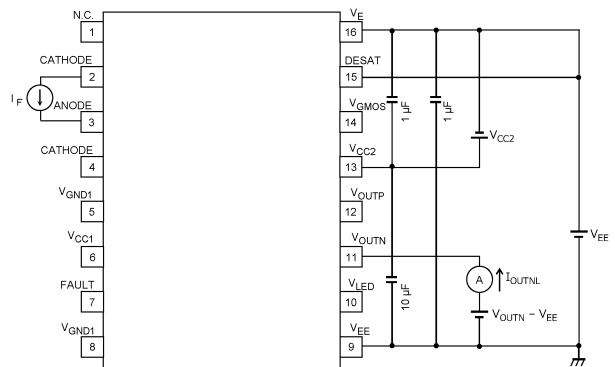

Fig. 13.1.4 I_{OUTNL} Test Circuit

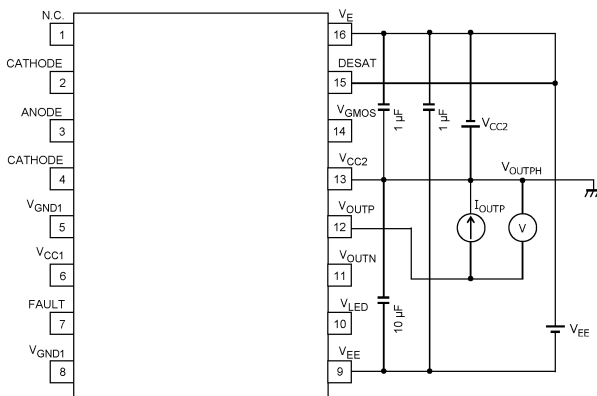

Fig. 13.1.5 V_{OUTPH}, R_{OUTPH} Test Circuit

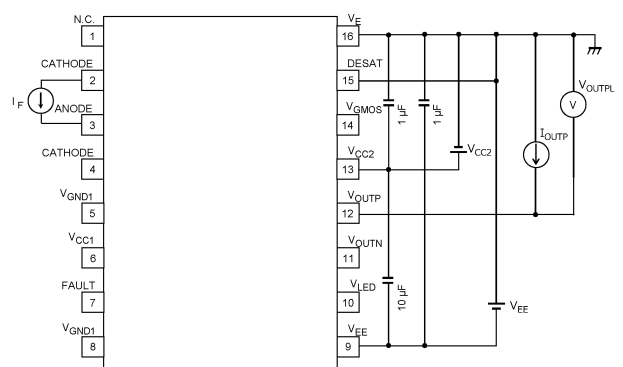

Fig. 13.1.6 V_{OUTPL}, R_{OUTPL} Test Circuit

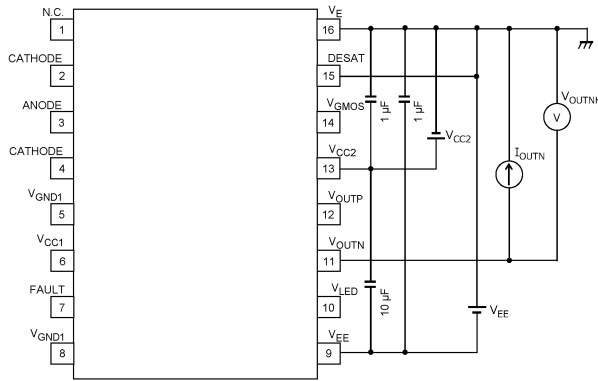

Fig. 13.1.7 VOUTNH, ROUTNH Test Circuit

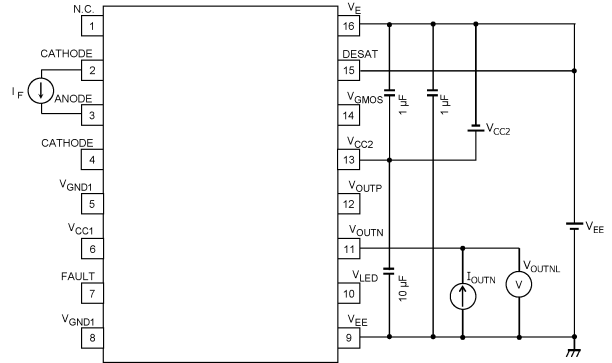

Fig. 13.1.8 VOUTNL, ROUTNL Test Circuit

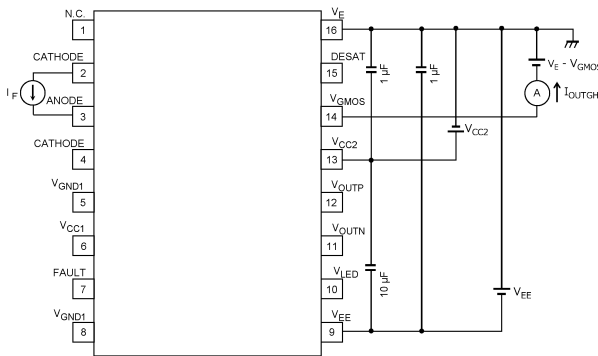

Fig. 13.1.9 IOUTGH Test Circuit

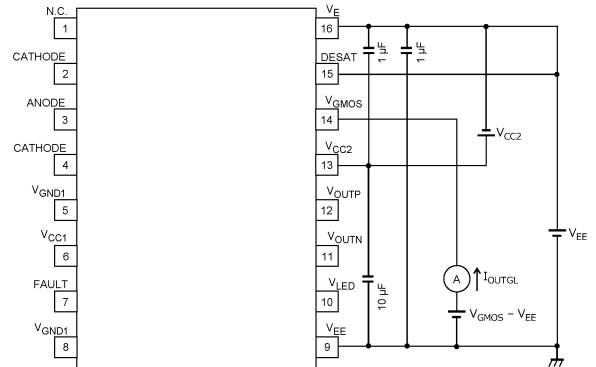

Fig. 13.1.10 IOUTGL Test Circuit

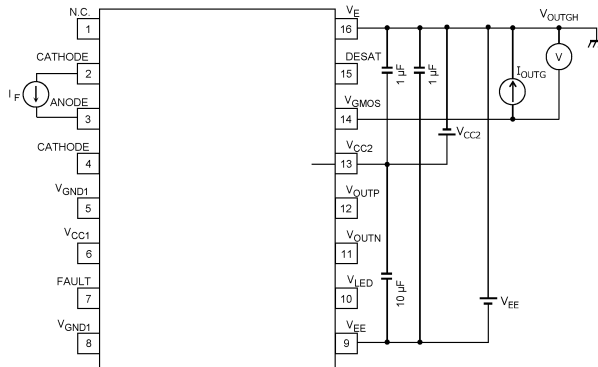

Fig. 13.1.11 VOUTGH, ROUTGH Test Circuit

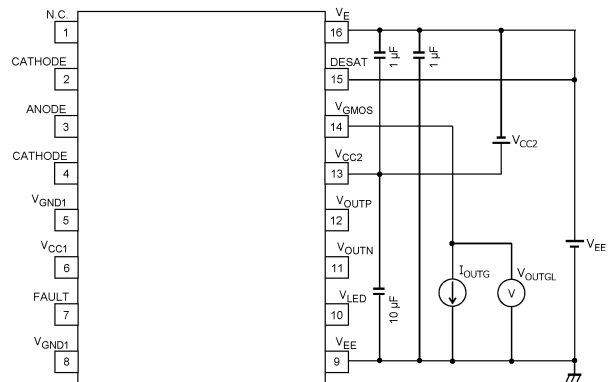

Fig. 13.1.12 VOUTGL, ROUTGL Test Circuit

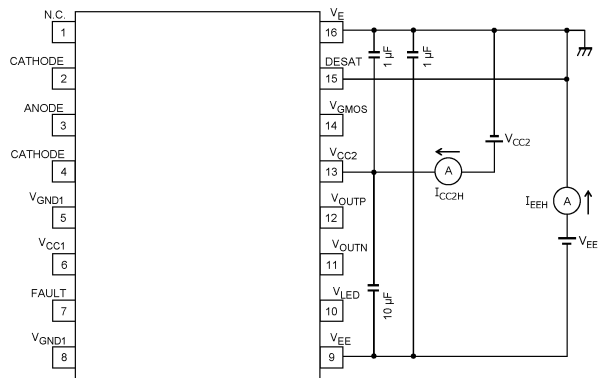

Fig. 13.1.13 ICC2H, IEEH Test Circuit

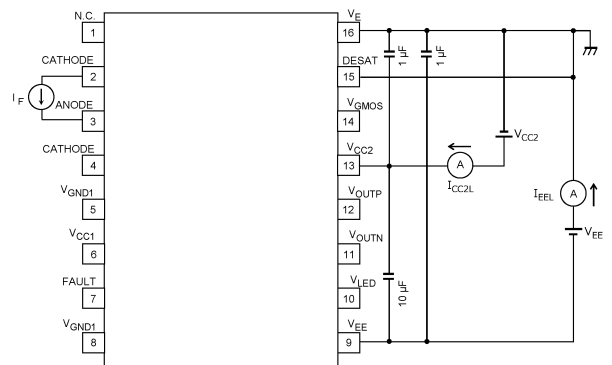

Fig. 13.1.14 ICC2L, IEEL Test Circuit

13.2. Timing Diagrams

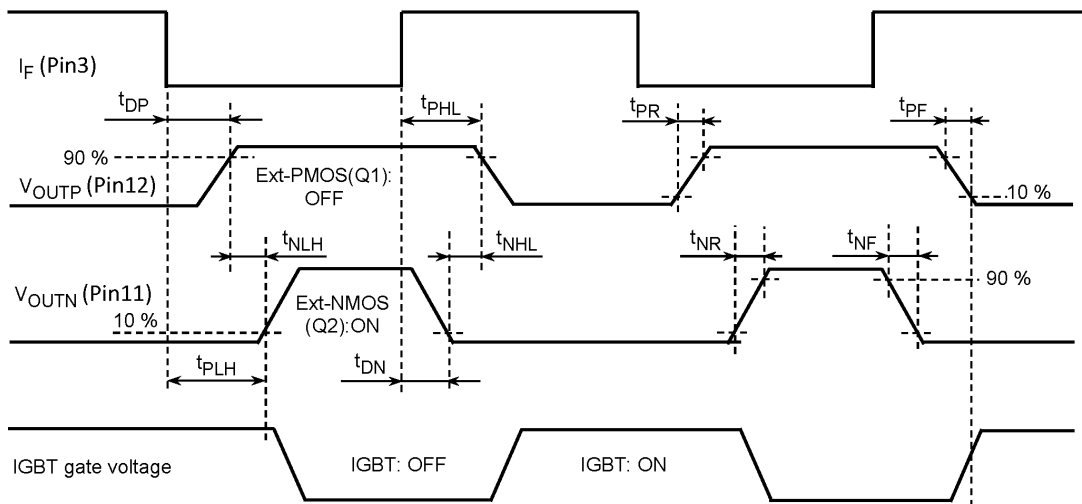

Fig. 13.2.1 Normal State

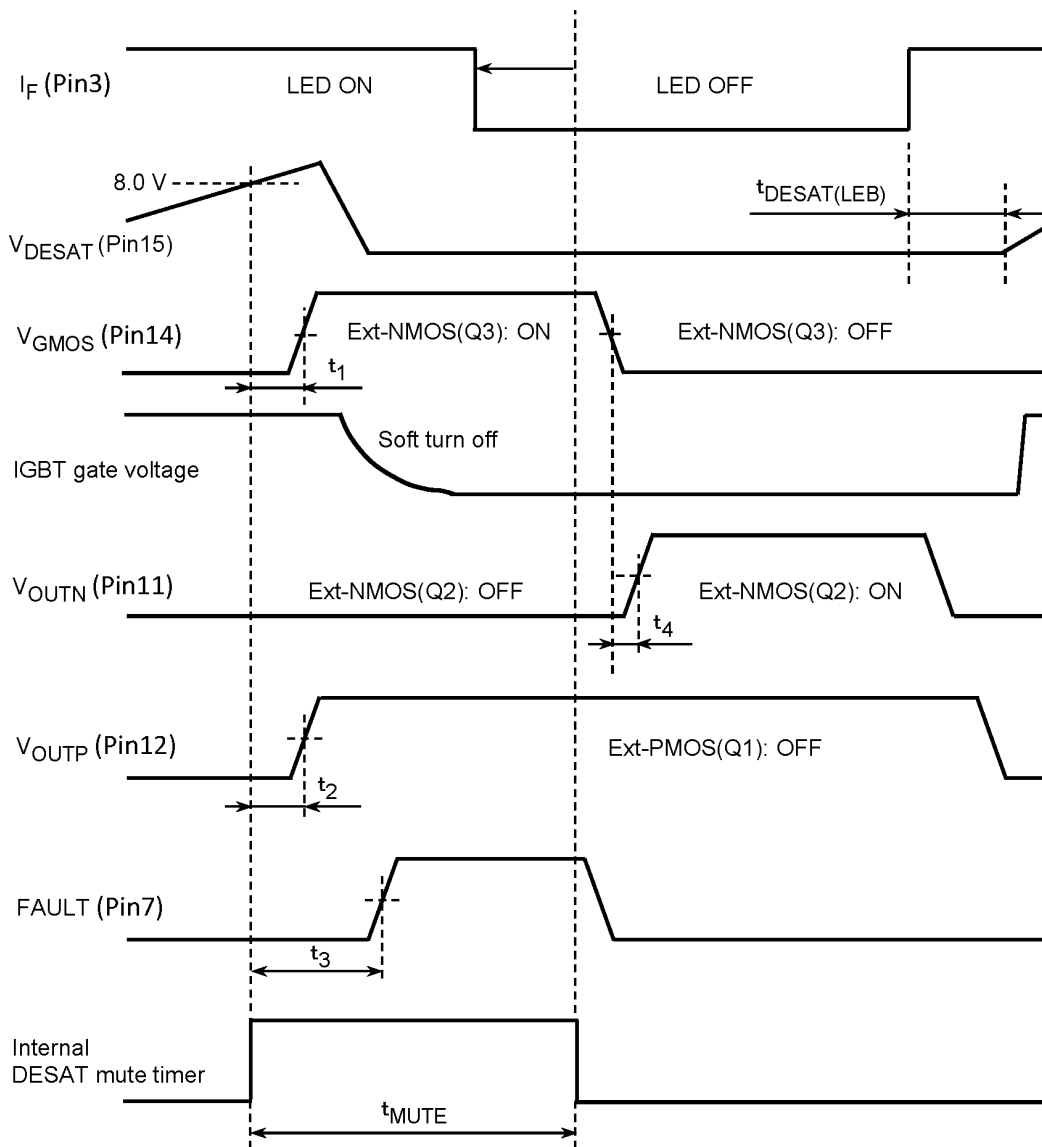

Fig. 13.2.2 DESAT Fault State (the Case that LED is Off within the t_{MUTE} : Automatic Reset)

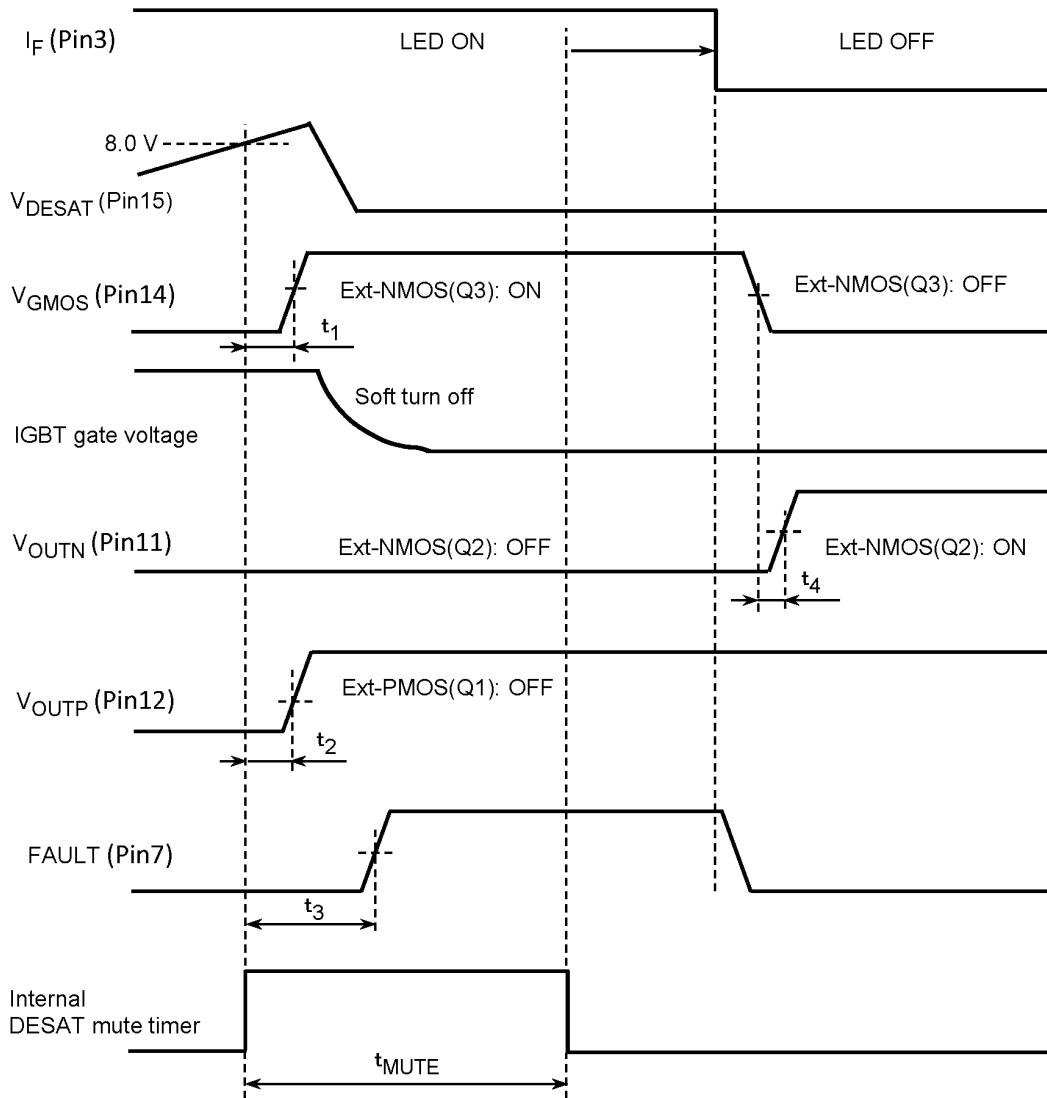

Fig. 13.2.3 DESAT Fault State (the Case that LED is Off after t_{MUTE} : Reset by LED Trigger)

13.3. Characteristics Curves (Note)

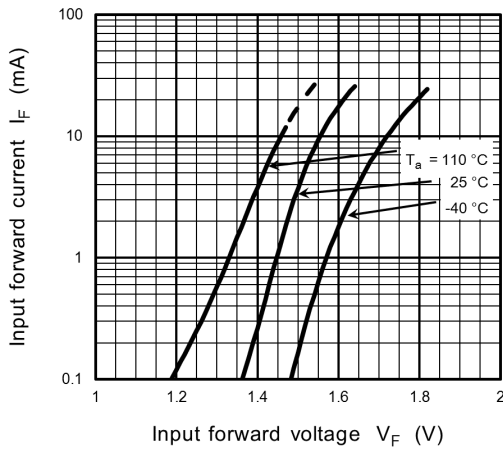

Fig. 13.3.1 $I_F - V_F$

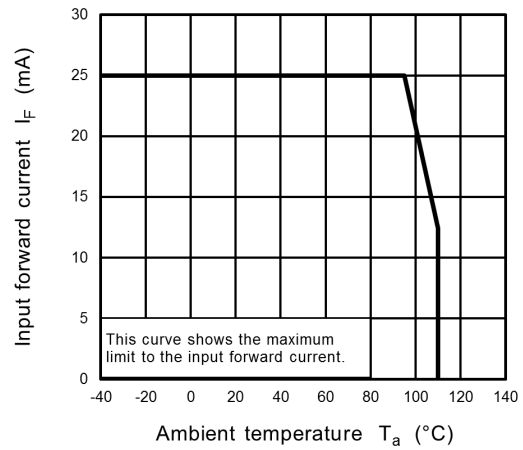

Fig. 13.3.2 $I_F - T_a$

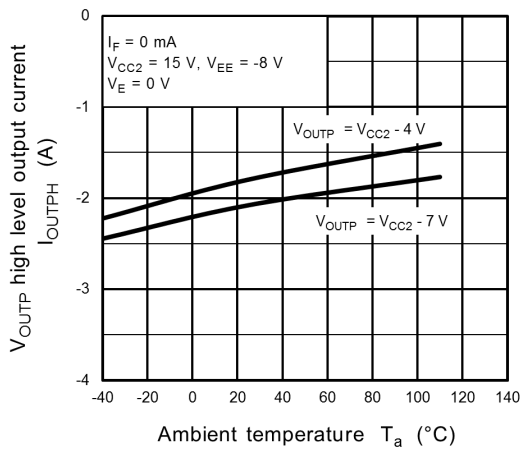

Fig. 13.3.3 $I_{OUTPH} - T_a$

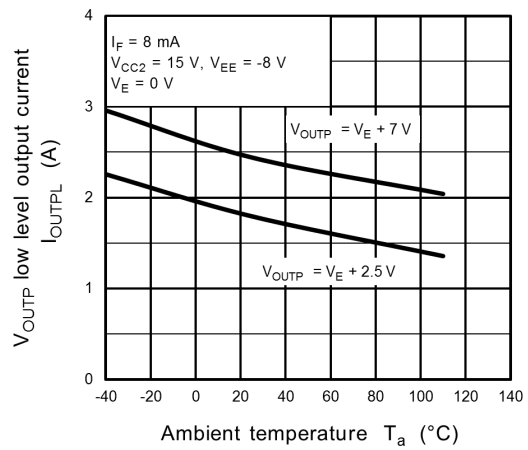

Fig. 13.3.4 $I_{OUTPL} - T_a$

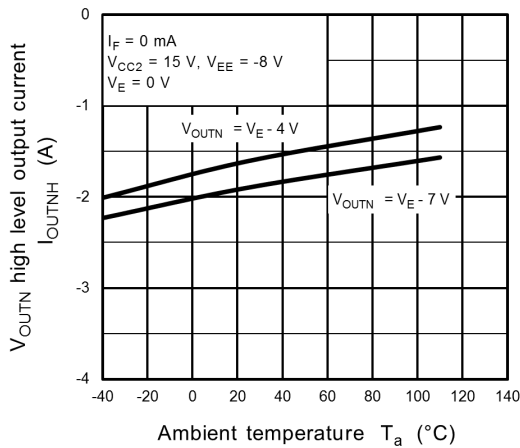

Fig. 13.3.5 $I_{OUTNH} - T_a$

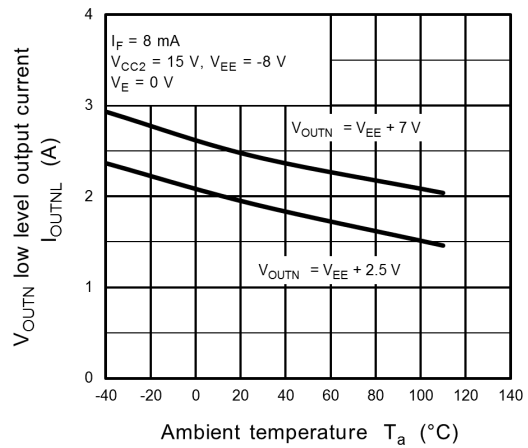

Fig. 13.3.6 $I_{OUTNL} - T_a$

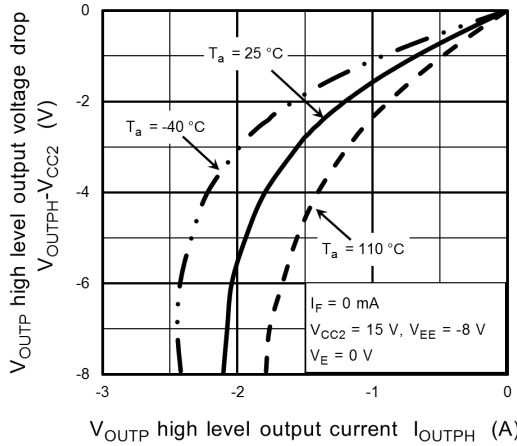

Fig. 13.3.7 $(V_{OUTPH} - V_{CC2}) - I_{OUTPH}$

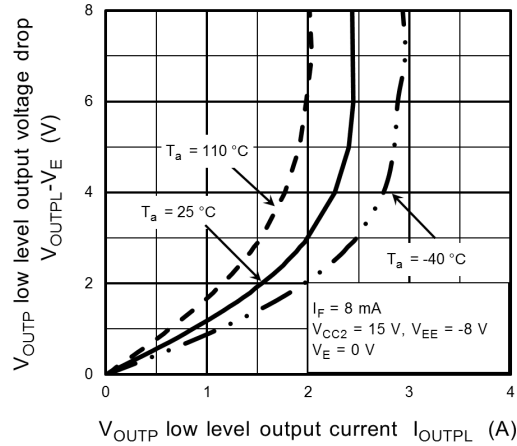

Fig. 13.3.8 $(V_{OUTPL} - V_E) - I_{OUTPL}$

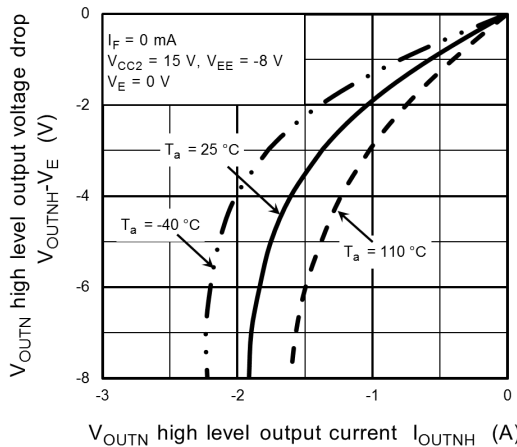

Fig. 13.3.9 $(V_{OUTNH} - V_E) - I_{OUTNH}$

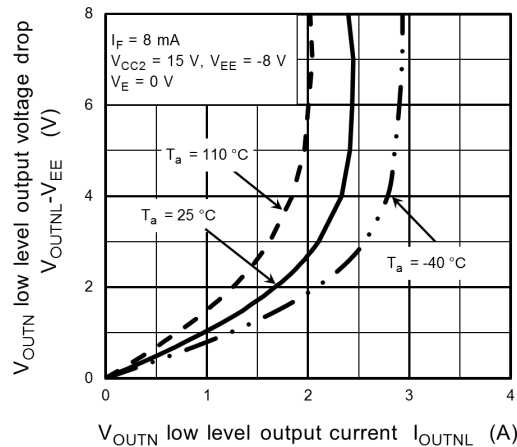

Fig. 13.3.10 $(V_{OUTNL} - V_{EE}) - I_{OUTNL}$

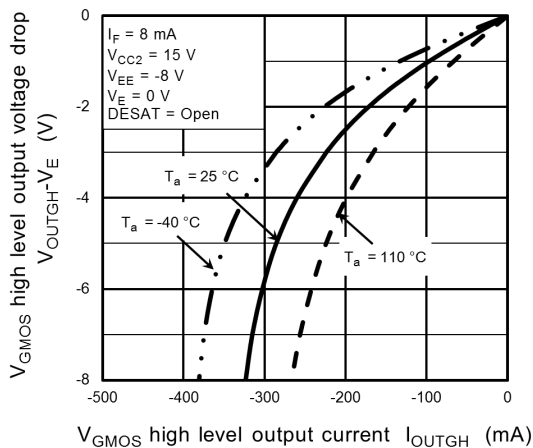

Fig. 13.3.11 $(V_{OUTGH} - V_E) - I_{OUTGH}$

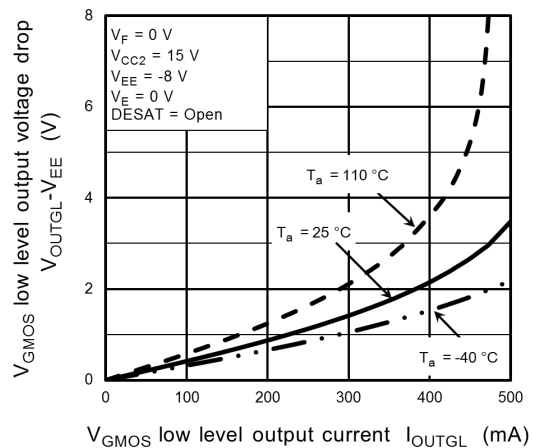

Fig. 13.3.12 $(V_{OUTGL} - V_{EE}) - I_{OUTGL}$

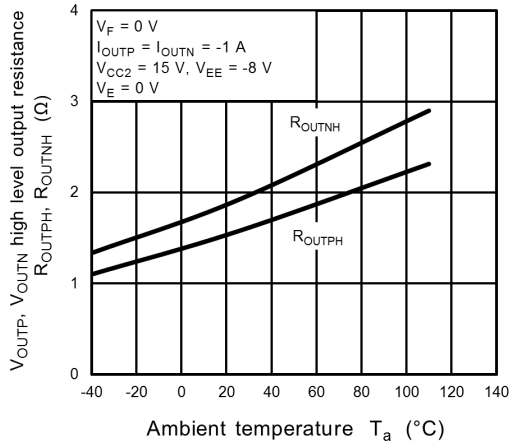

Fig. 13.3.13 $R_{OUTPH}, R_{OUTNH} - T_a$

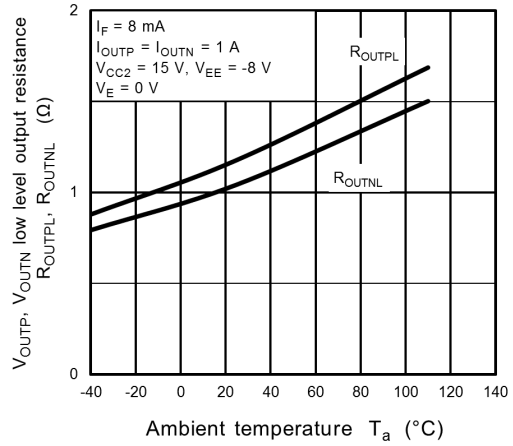

Fig. 13.3.14 $R_{OUTPL}, R_{OUTNL} - T_a$

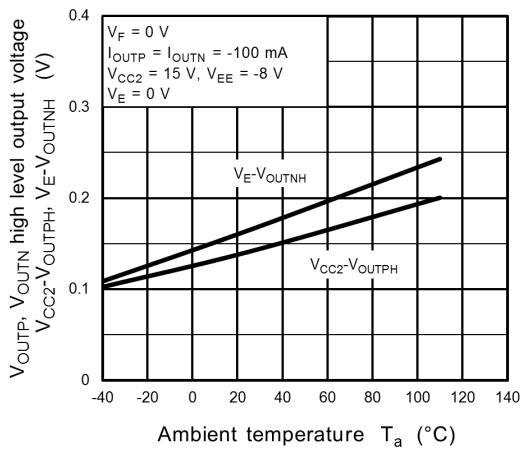

Fig. 13.3.15 $V_{CC2} - V_{OUTPH}, V_E - V_{OUTNH} - T_a$

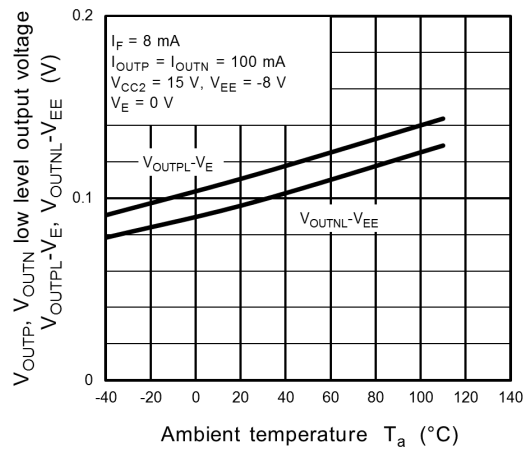

Fig. 13.3.16 $V_{OUTPL} - V_E, V_{OUTNL} - V_{EE} - T_a$

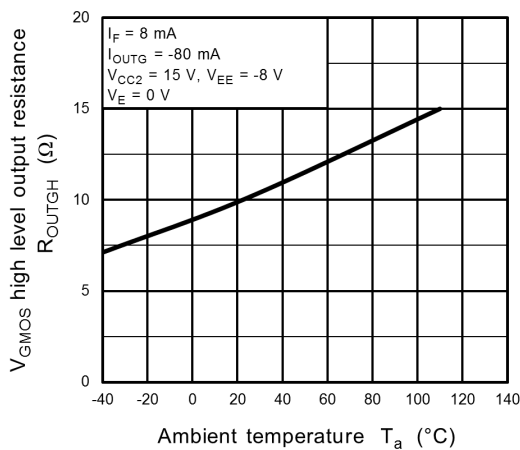

Fig. 13.3.17 $R_{OUTGH} - T_a$

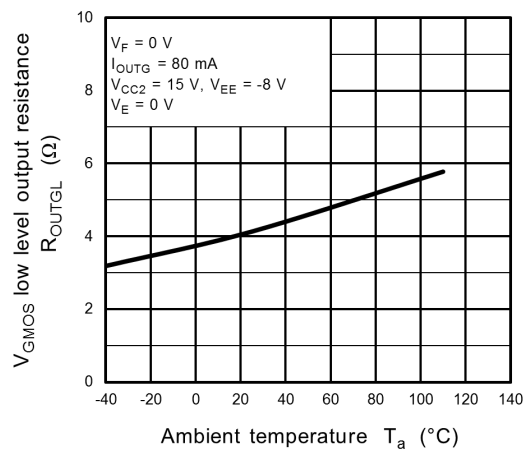

Fig. 13.3.18 $R_{OUTGL} - T_a$

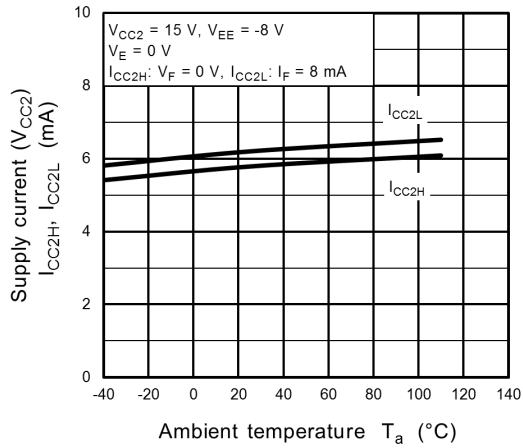

Fig. 13.3.19 $I_{CC2H}, I_{CC2L} - T_a$

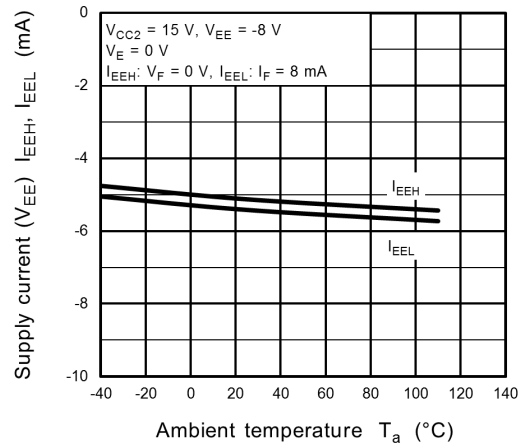

Fig. 13.3.20 $I_{EEH}, I_{EEL} - T_a$

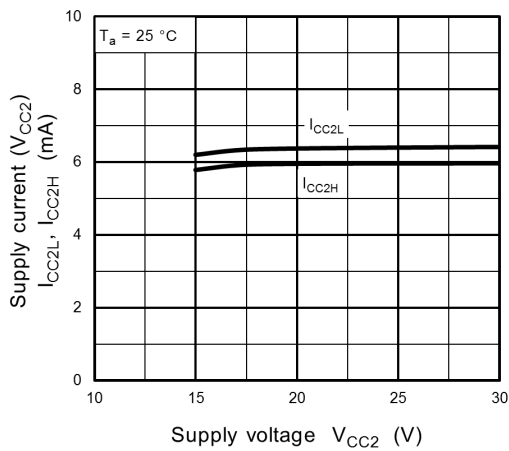

Fig. 13.3.21 $I_{CC2H}, I_{CC2L} - V_{CC2}$

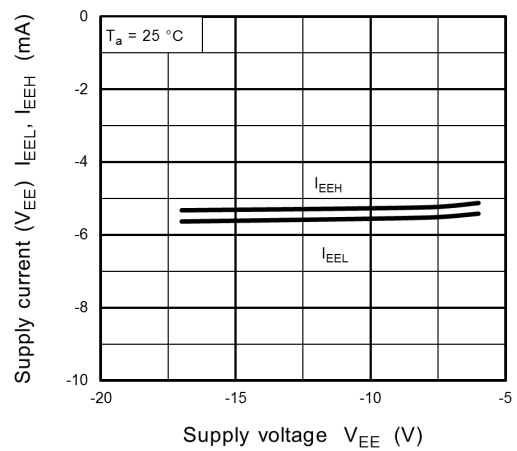

Fig. 13.3.22 $I_{EEH}, I_{EEL} - V_{EE}$

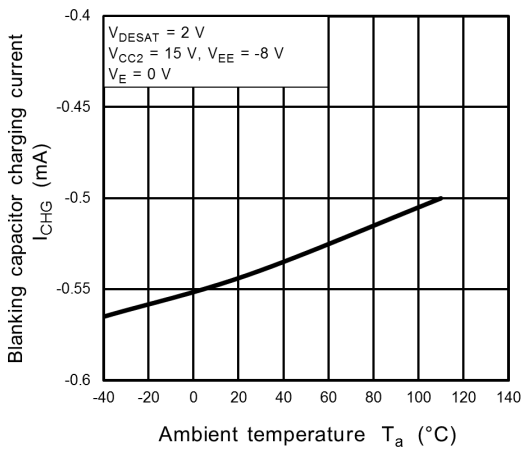

Fig. 13.3.23 $I_{CHG} - T_a$

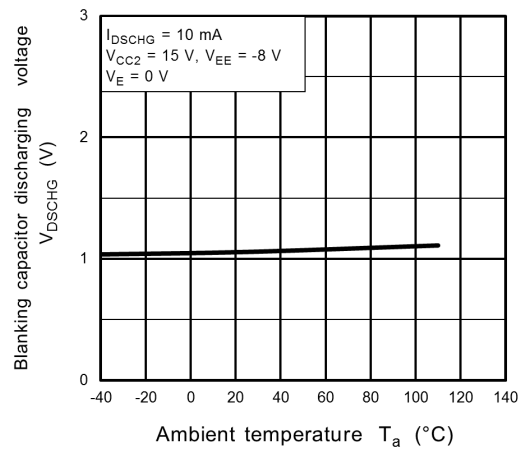

Fig. 13.3.24 $V_{DSCHG} - T_a$

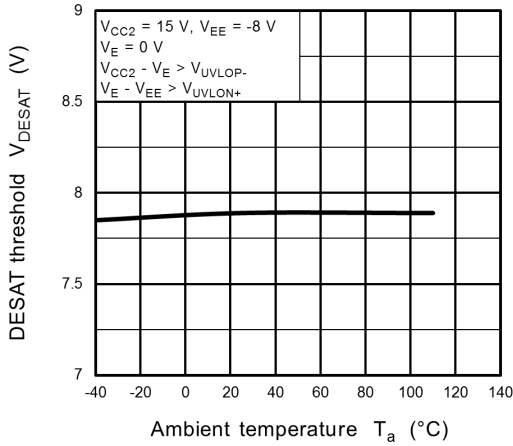

Fig. 13.3.25 $V_{DESAT} - T_a$

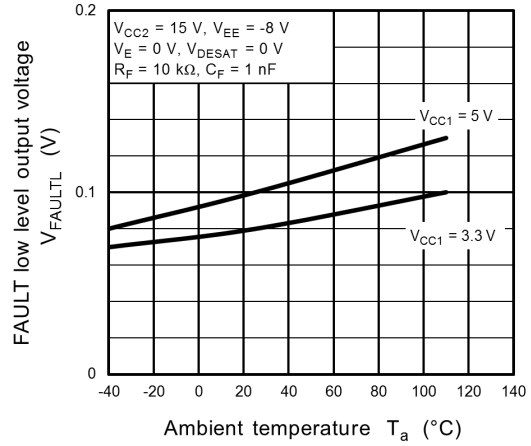

Fig. 13.3.26 $V_{FAULTL} - T_a$

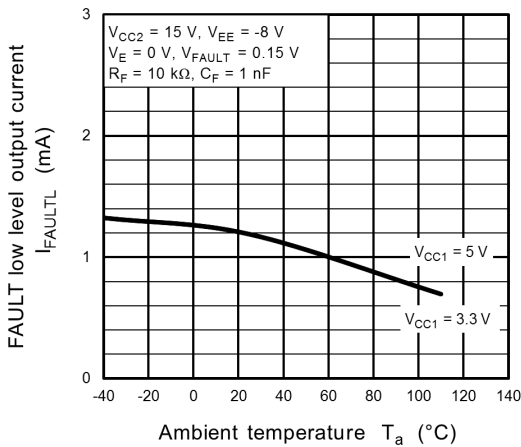

Fig. 13.3.27 $I_{FAULTL} - T_a$

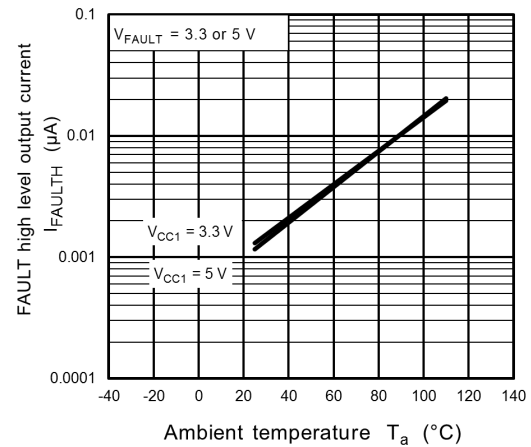

Fig. 13.3.28 $I_{FAULTH} - T_a$

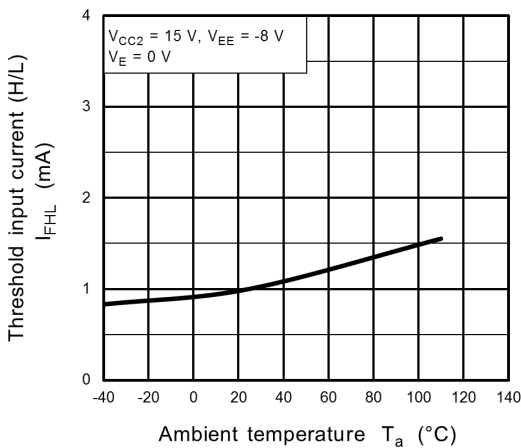

Fig. 13.3.29 $I_{FHL} - T_a$

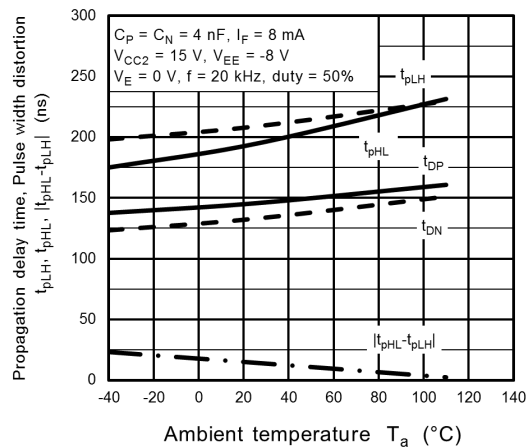

Fig. 13.3.30 $t_{pLH}, t_{pHL}, |t_{pHL} - t_{pLH}| - T_a$

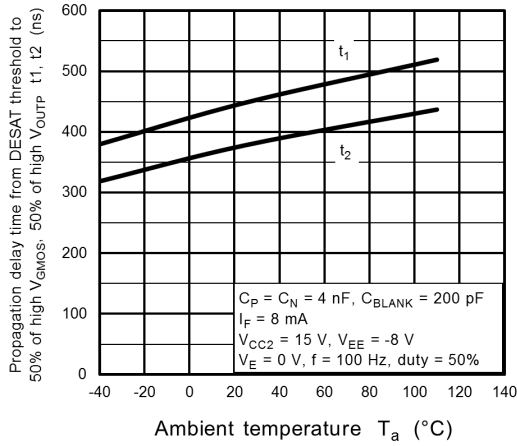

Fig. 13.3.31 $t_1, t_2 - T_a$

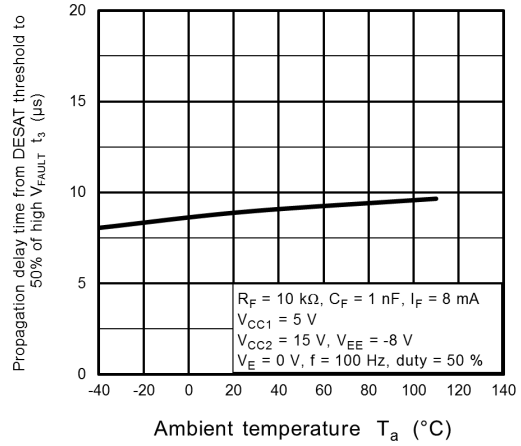

Fig. 13.3.32 $t_3 - T_a$

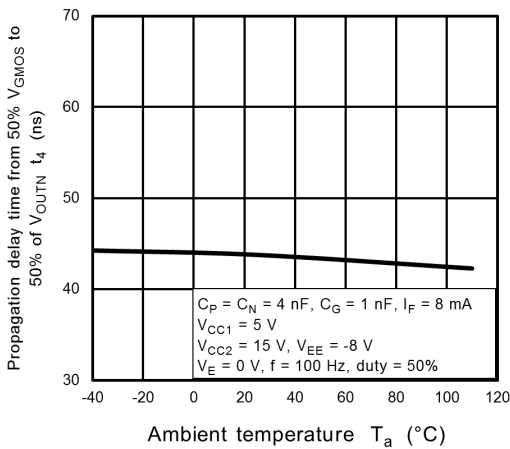

Fig. 13.3.33 $t_4 - T_a$

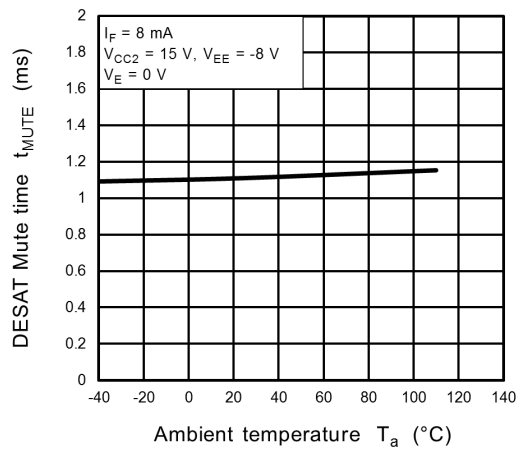

Fig. 13.3.34 $t_{MUTE} - T_a$

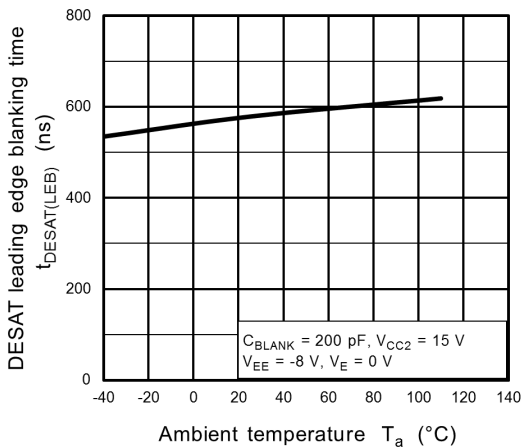

Fig. 13.3.35 $t_{DESAT(LEB)} - T_a$

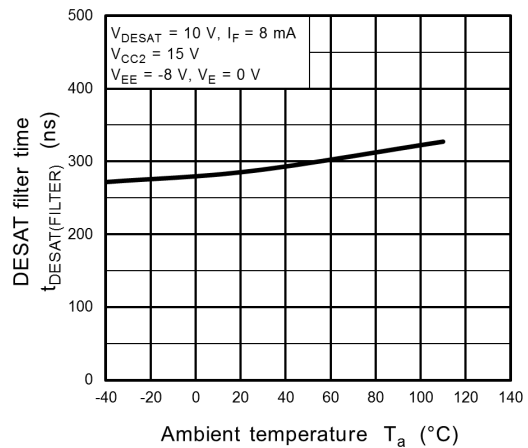

Fig. 13.3.36 $t_{DESAT(FILTER)} - T_a$

Note: The above characteristics curves are presented for reference only and not guaranteed by production test, unless otherwise noted.

14. Soldering and Storage

14.1. Precautions for Soldering

The soldering temperature should be controlled as closely as possible to the conditions shown below, irrespective of whether a soldering iron or a reflow soldering method is used.

- When using soldering reflow.

The soldering temperature profile is based on the package surface temperature.

(See the figure shown below, which is based on the package surface temperature.)

Reflow soldering must be performed once or twice.

The mounting should be completed with the interval from the first to the last mountings being 2 weeks.

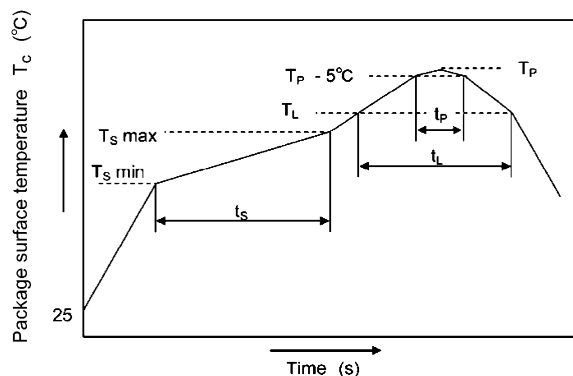

	Symbol	Min	Max	Unit
Preheat temperature	T_s	150	200	°C
Preheat time	t_s	60	120	s
Ramp-up rate (T_L to T_P)			3	°C/s
Liquidus temperature	T_L	217		°C
Time above T_L	t_L	60	150	s
Peak temperature	T_P		260	°C
Time during which T_c is between ($T_P - 5$) and T_P	t_p		30	s
Ramp-down rate (T_P to T_L)			6	°C/s

An Example of a Temperature Profile When Lead(Pb)-Free Solder Is Used

- When using soldering flow
Preheat the device at a temperature of 150 °C (package surface temperature) for 60 to 120 seconds.
Mounting condition of 260 °C within 10 seconds is recommended.
Flow soldering must be performed once.
- When using soldering Iron
Complete soldering within 10 seconds for lead temperature not exceeding 260 °C or within 3 seconds not exceeding 350 °C
Heating by soldering iron must be done only once per lead.

14.2. Precautions for General Storage

- Avoid storage locations where devices may be exposed to moisture or direct sunlight.
- Follow the precautions printed on the packing label of the device for transportation and storage.
- Keep the storage location temperature and humidity within a range of 5 °C to 35 °C and 45 % to 75 %, respectively.
- Do not store the products in locations with poisonous gases (especially corrosive gases) or in dusty conditions.
- Store the products in locations with minimal temperature fluctuations. Rapid temperature changes during storage can cause condensation, resulting in lead oxidation or corrosion, which will deteriorate the solderability of the leads.
- When restoring devices after removal from their packing, use anti-static containers.
- Do not allow loads to be applied directly to devices while they are in storage.
- If devices have been stored for more than two years under normal storage conditions, it is recommended that you check the leads for ease of soldering prior to use.

15. Land Pattern Dimensions (for reference only)

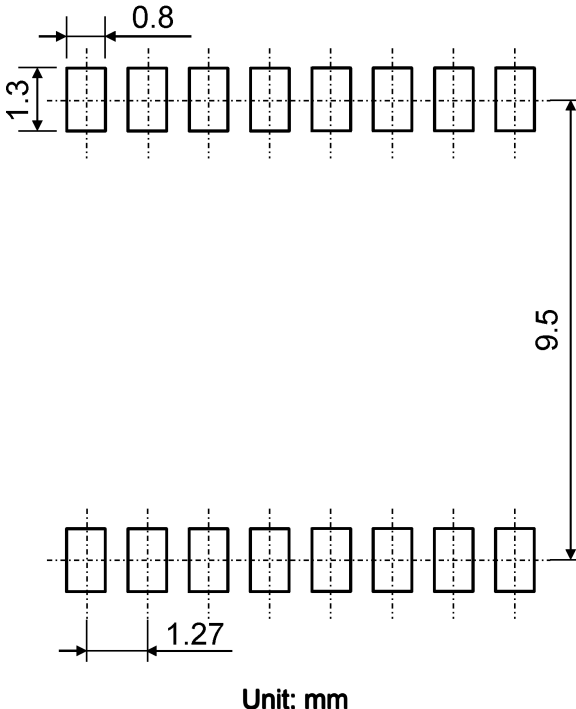

16. Marking

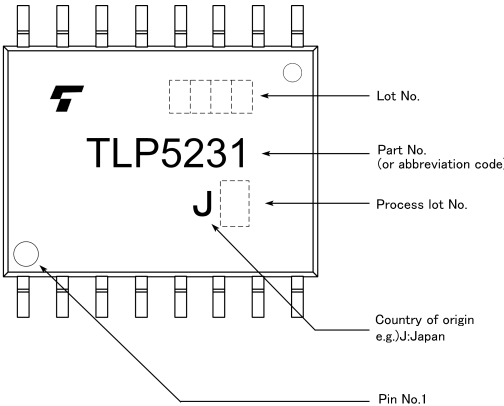

17. EN 60747-5-5 Option (D4) Specification

- Part number: TLP5231 (**Note 1**)
- The following part naming conventions are used for the devices that have been qualified according to option (D4) of EN 60747.

Example: TLP5231(D4-TP,E)

D4: EN 60747 option

TP: Tape type

E: [[G]]/RoHS COMPATIBLE (**Note 2**)

Note 1: Use TOSHIBA standard type number for safety standard application.
e.g., TLP5231(D4-TP,E → TLP5231

Note 2: Please contact your Toshiba sales representative for details on environmental information such as the product's RoHS compatibility.

RoHS is the Directive 2011/65/EU of the European Parliament and of the Council of 8 June 2011 on the restriction of the use of certain hazardous substances in electrical and electronic equipment.

Description	Symbol	Rating	Unit
Application classification for rated mains voltage ≤ 600 Vrms for rated mains voltage ≤ 1000 Vrms		I-IV I-III	—
Climatic classification		40 / 110 / 21	—
Pollution degree		2	—
Maximum operating insulation voltage	VIORM	1230	Vpeak
Input to output test voltage, Method A $V_{pr} = 1.6 \times VIORM$, type and sample test $t_p = 10$ s, partial discharge < 5 pC	Vpr	1970	Vpeak
Input to output test voltage, Method B $V_{pr} = 1.875 \times VIORM$, 100 % production test $t_p = 1$ s, partial discharge < 5 pC	Vpr	2310	Vpeak
Highest permissible overvoltage (transient overvoltage, $t_{pr} = 60$ s)	VTR	8000	Vpeak
Safety limiting values (max. permissible ratings in case of fault, also refer to thermal derating curve) current (input current I_F , $P_{SO} = 0$) power (output or total power dissipation) temperature	Isi Pso Ts	400 1200 175	mA mW °C
Insulation resistance $V_{IO} = 500$ V, $T_a = 25$ °C $V_{IO} = 500$ V, $T_a = 100$ °C $V_{IO} = 500$ V, $T_a = T_s$	Rsi	$\geq 10^{12}$ $\geq 10^{11}$ $\geq 10^9$	Ω

Fig. 17.1 EN 60747 Insulation Characteristics

Minimum creepage distance	Cr	8.0 mm
Minimum clearance	Cl	8.0 mm
Minimum insulation thickness	ti	0.4 mm
Comparative tracking index	CTI	500

Fig. 17.2 Insulation Related Specifications (Note)

Note: This photocoupler is suitable for **safe electrical isolation** only within the safety limit data. Maintenance of the safety data shall be ensured by means of protective circuits.



Fig. 17.3 Marking on Packing for EN 60747

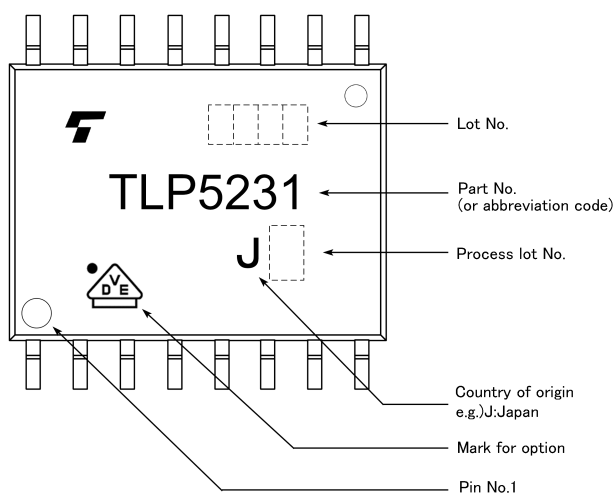

Fig. 17.4 Marking Example (Note)

Note: The above marking is applied to the photocouplers that have been qualified according to option (D4) of EN 60747.

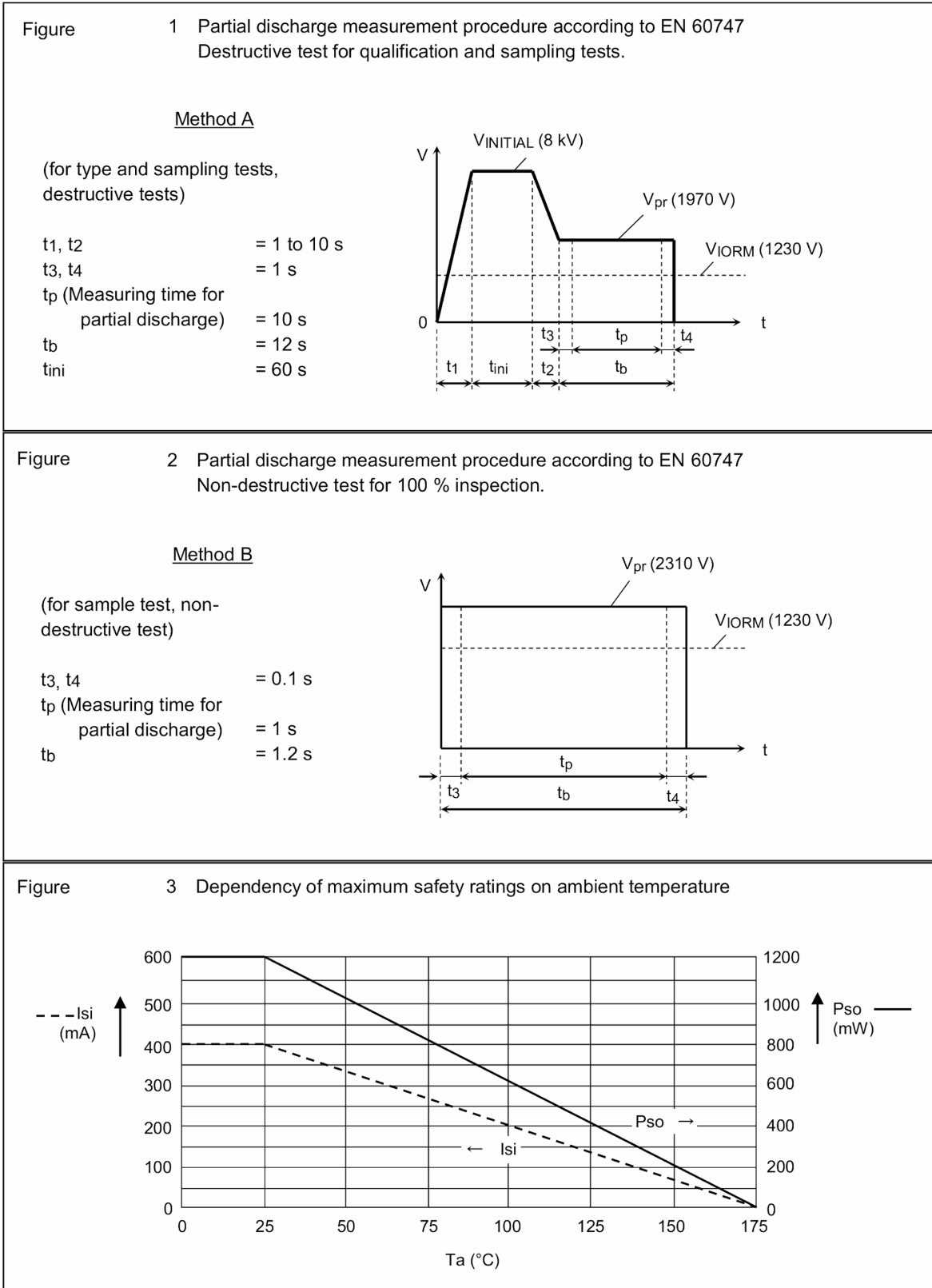

Fig. 17.5 Measurement Procedure

18. Ordering Information (Example of Item Name)

Item Name	VDE Option	Packing (MOQ)
TLP5231(E		Magazine (50 pcs)
TLP5231(TP,E		Tape and reel (1500 pcs)
TLP5231(D4,E	EN 60747-5-5	Magazine (50 pcs)
TLP5231(D4-TP,E	EN 60747-5-5	Tape and reel (1500 pcs)

RESTRICTIONS ON PRODUCT USE

Toshiba Corporation and its subsidiaries and affiliates are collectively referred to as "TOSHIBA".

Hardware, software and systems described in this document are collectively referred to as "Product".

- TOSHIBA reserves the right to make changes to the information in this document and related Product without notice.
- This document and any information herein may not be reproduced without prior written permission from TOSHIBA. Even with TOSHIBA's written permission, reproduction is permissible only if reproduction is without alteration/omission.
- Though TOSHIBA works continually to improve Product's quality and reliability, Product can malfunction or fail. Customers are responsible for complying with safety standards and for providing adequate designs and safeguards for their hardware, software and systems which minimize risk and avoid situations in which a malfunction or failure of Product could cause loss of human life, bodily injury or damage to property, including data loss or corruption. Before customers use the Product, create designs including the Product, or incorporate the Product into their own applications, customers must also refer to and comply with (a) the latest versions of all relevant TOSHIBA information, including without limitation, this document, the specifications, the data sheets and application notes for Product and the precautions and conditions set forth in the "TOSHIBA Semiconductor Reliability Handbook" and (b) the instructions for the application with which the Product will be used with or for. Customers are solely responsible for all aspects of their own product design or applications, including but not limited to (a) determining the appropriateness of the use of this Product in such design or applications; (b) evaluating and determining the applicability of any information contained in this document, or in charts, diagrams, programs, algorithms, sample application circuits, or any other referenced documents; and (c) validating all operating parameters for such designs and applications.
TOSHIBA ASSUMES NO LIABILITY FOR CUSTOMERS' PRODUCT DESIGN OR APPLICATIONS.

- **PRODUCT IS NEITHER INTENDED NOR WARRANTED FOR USE IN EQUIPMENTS OR SYSTEMS THAT REQUIRE EXTRAORDINARILY HIGH LEVELS OF QUALITY AND/OR RELIABILITY, AND/OR A MALFUNCTION OR FAILURE OF WHICH MAY CAUSE LOSS OF HUMAN LIFE, BODILY INJURY, SERIOUS PROPERTY DAMAGE AND/OR SERIOUS PUBLIC IMPACT ("UNINTENDED USE").**

Except for specific applications as expressly stated in this document, Unintended Use includes, without limitation, equipment used in nuclear facilities, equipment used in the aerospace industry, lifesaving and/or life supporting medical equipment, equipment used for automobiles, trains, ships and other transportation, traffic signaling equipment, equipment used to control combustions or explosions, safety devices, elevators and escalators, and devices related to power plant.

IF YOU USE PRODUCT FOR UNINTENDED USE, TOSHIBA ASSUMES NO LIABILITY FOR PRODUCT.

For details, please contact your TOSHIBA sales representative or contact us via our website.

- Do not disassemble, analyze, reverse-engineer, alter, modify, translate or copy Product, whether in whole or in part.
- Product shall not be used for or incorporated into any products or systems whose manufacture, use, or sale is prohibited under any applicable laws or regulations.
- The information contained herein is presented only as guidance for Product use. No responsibility is assumed by TOSHIBA for any infringement of patents or any other intellectual property rights of third parties that may result from the use of Product. No license to any intellectual property right is granted by this document, whether express or implied, by estoppel or otherwise.
- **ABSENT A WRITTEN SIGNED AGREEMENT, EXCEPT AS PROVIDED IN THE RELEVANT TERMS AND CONDITIONS OF SALE FOR PRODUCT, AND TO THE MAXIMUM EXTENT ALLOWABLE BY LAW, TOSHIBA (1) ASSUMES NO LIABILITY WHATSOEVER, INCLUDING WITHOUT LIMITATION, INDIRECT, CONSEQUENTIAL, SPECIAL, OR INCIDENTAL DAMAGES OR LOSS, INCLUDING WITHOUT LIMITATION, LOSS OF PROFITS, LOSS OF OPPORTUNITIES, BUSINESS INTERRUPTION AND LOSS OF DATA, AND (2) DISCLAIMS ANY AND ALL EXPRESS OR IMPLIED WARRANTIES AND CONDITIONS RELATED TO SALE, USE OF PRODUCT, OR INFORMATION, INCLUDING WARRANTIES OR CONDITIONS OF MERCHANTABILITY, FITNESS FOR A PARTICULAR PURPOSE, ACCURACY OF INFORMATION, OR NONINFRINGEMENT.**
- GaAs (Gallium Arsenide) is used in Product. GaAs is harmful to humans if consumed or absorbed, whether in the form of dust or vapor. Handle with care and do not break, cut, crush, grind, dissolve chemically or otherwise expose GaAs in Product.
- Do not use or otherwise make available Product or related software or technology for any military purposes, including without limitation, for the design, development, use, stockpiling or manufacturing of nuclear, chemical, or biological weapons or missile technology products (mass destruction weapons). Product and related software and technology may be controlled under the applicable export laws and regulations including, without limitation, the Japanese Foreign Exchange and Foreign Trade Law and the U.S. Export Administration Regulations. Export and re-export of Product or related software or technology are strictly prohibited except in compliance with all applicable export laws and regulations.
- Please contact your TOSHIBA sales representative for details as to environmental matters such as the RoHS compatibility of Product. Please use Product in compliance with all applicable laws and regulations that regulate the inclusion or use of controlled substances, including without limitation, the EU RoHS Directive. **TOSHIBA ASSUMES NO LIABILITY FOR DAMAGES OR LOSSES OCCURRING AS A RESULT OF NONCOMPLIANCE WITH APPLICABLE LAWS AND REGULATIONS.**

X-ON Electronics

Largest Supplier of Electrical and Electronic Components

Click to view similar products for [Logic Output Opto-couplers](#) category:

Click to view products by [Toshiba](#) manufacturer:

Other Similar products are found below :

[CPC1590P](#) [TLP705A\(F\)](#) [TLP700A\(F\)](#) [FOD3150](#) [TLP2348](#) [VO3120-X001](#) [ACPL-W343-560E](#) [ACPL-W340-560E](#) [H11L2S\(TA\)-V](#) [ACPL-P347-500E](#) [ACPL-P347-560E](#) [ACNT-H343-500E](#) [TLP5772H\(TP4,E](#) [TLP5772H\(TP,E](#) [TLP5771H\(TP4,E](#) [TLP5774H\(TP,E](#) [TLP5772H\(D4,E](#) [TLP5772H\(LF4,E](#) [TLP5771H\(D4,E](#) [TLP5774H\(D4,E](#) [TLP5771H\(E](#) [TLP5772H\(D4LF4,E](#) [TLP5774H\(LF4,E](#) [TLP5771H\(D4LF4,E](#) [TLP5771H\(LF4,E](#) [TLP5774H\(E](#) [H11L1S\(TA\)](#) [H11L3SR2M](#) [HCPL-0302-000E](#) [HCPL3700SD](#) [TLP155E\(TPL,E\)](#) [TLP2345\(E\(T](#) [TLP2348\(E\(T](#) [TLP350H\(F\)](#) [TLP701AF\(F\)](#) [TLP351H\(F\)](#) [TLP5214\(TP,E\(O](#) [TLP5702\(TP,E](#) [TLP351H\(TP1,F\)](#) [FOD3120SDV](#) [FOD8160](#) [FOD3184TSR2V](#) [6N140A/883B](#) [HCPL-0466-500E](#) [HCPL-6750](#) [TLP700AF\(F\)](#) [TLP152\(TPL,E](#) [HCPL-5730](#) [OPIA804DTUE](#) [8302401EA](#)