

TMPM333FDFG TMPM333FYFG TMPM333FWFG



High-performance microcontrollers based on ARM® Cortex®-M3 core, featuring a high-speed low-power FLASH-ROM, a 10-bit AD converter, various interfaces and timers.

Features

ARM® Cortex®-M3 CPU Core

- ▶ Operating voltage: 2.7 to 3.6V
- ▶ Maximum Operating frequency: 40 MHz (10 MHz × 4 by PLL)
- ▶ High-speed Flash programming

Built-in Functions

- ▶ 10-bit AD converter (1.15µs) : 12 channels
- ▶ 16-bit timer : 10 channels
- ▶ SIO/UART : 3 channels
- ▶ I²C/SIO : 3 channels

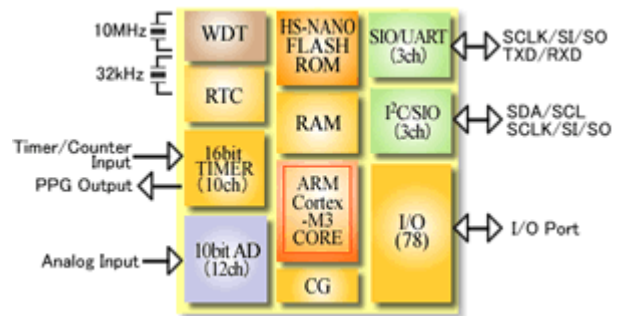

Flash Memory Size

Part number	ROM (Flash)	RAM
TMPM333FDFG	512 Kbytes	32 Kbytes
TMPM333FYFG	256 Kbytes	16 Kbytes
TMPM333FWFG	128 Kbytes	8 Kbytes

* ARM and Cortex are the registered trademarks of ARM Limited in the EU and other countries.

* NANO FLASH™ is a trademark of Toshiba Corporation.

Package Information

Pin Assignments

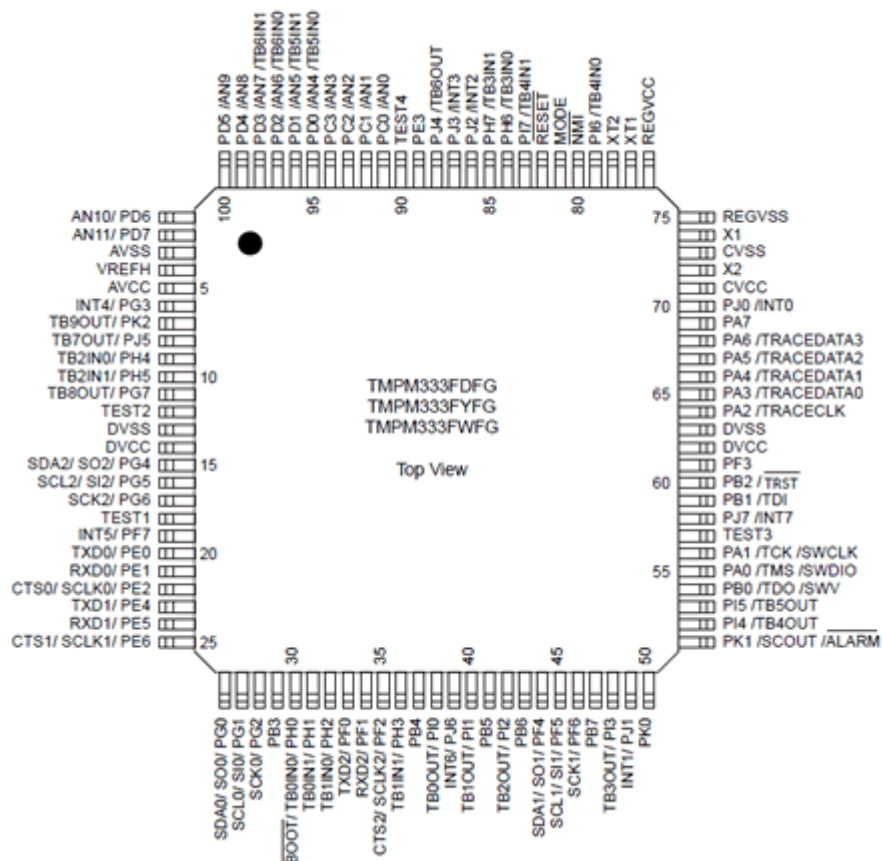

Package name: LQFP-100-P-1414-0.50H

Pin Numbers and Names

Pin No.	Pin name	Pin No.	Pin name
1	PD6, AN10	26	PG0, SO0, SDA0
2	PD7, AN11	27	PG1, SI0, SCL0
3	AVSS	28	PG2, SCK0
4	VREFH	29	PB3
5	AVCC	30	PH0, TB0IN0, $\overline{\text{BOOT}}$
6	PG3, INT4	31	PH1, TB0IN1
7	PK2, TB9OUT	32	PH2, TB1IN0
8	PJ5, TB7OUT	33	PF0, TXD2
9	PH4, TB2IN0	34	PF1, RXD2
10	PH5, TB2IN1	35	PF2, SCL2, CTS2
11	PG7, TB8OUT	36	PH3, TB1IN1
12	TEST2	37	PB4
13	DVSS	38	PI0, TB0OUT
14	DVCC	39	PJ6, INT6
15	PG4, SO2, SDA2	40	PI1, TB1OUT
16	PG5, SI2, SCL2	41	PB5
17	PG6, SCK2	42	PI2, TB2OUT
18	TEST1	43	PB6
19	PF7, INT5	44	PF4, SO1, SDA1
20	PE0, TXD0	45	PF5, SI1, SCL1
21	PE1, RXD0	46	PF6, SCK1
22	PE2, SCLK0, CTS0	47	PB7
23	PE4, TXD1	48	PI3, TB3OUT
24	PE5, RXD1	49	PJ1, INT1
25	PE6, SCLK1, CTS1	50	PK0,

Pin No.	Pin name	Pin No.	Pin name
51	PK1, SCOUT, ALARM	76	REGVCC
52	PI4, TB4OUT	77	XT1
53	PI5, TB5OUT	78	XT2
54	PB0, TDO, SWV	79	PI6, TB4IN0
55	PA0, TMS, SWDIO	80	NMI
56	PA1, TCK, SWCLK	81	MODE
57	TEST3	82	RESET
58	PJ7, INT7	83	PI7, TB4IN1
59	PB1, TDI	84	PH6, TB3IN0
60	PB2, TRST	85	PH7, TB3IN1
61	PF3	86	PJ2, INT2
62	DVCC	87	PJ3, INT3
63	DVSS	88	PJ4, TB6OUT
64	PA2, TRACECLK	89	PE3
65	PA3, TRACEDATA0	90	TEST4
66	PA4, TRACEDATA1	91	PC0, AN0
67	PA5, TRACEDATA2	92	PC1, AN1
68	PA6, TRACEDATA3	93	PC2, AN2
69	PA7	94	PC3, AN3
70	PJ0, INTO	95	PD0, AN4, TB5IN0
71	CVCC	96	PD1, AN5, TB5IN1
72	X2	97	PD2, AN6, TB6IN0
73	CVSS	98	PD3, AN7, TB6IN1
74	X1	99	PD4, AN8
75	REGVSS	100	PD5, AN9

» For further information about Toshiba microcomputers and Toshiba microcomputer development systems, please visit <http://www.semicon.toshiba.co.jp/eng/product/micro/index.html>

- Toshiba Corporation, and its subsidiaries and affiliates (collectively "TOSHIBA"), reserve the right to make changes to the information in this document, and related hardware, software and systems (collectively "Product") without notice.
- This document and any information herein may not be reproduced without prior written permission from TOSHIBA. Even with TOSHIBA's written permission, reproduction is permissible only if reproduction is without alteration/omission.
- Though TOSHIBA works continually to improve Product's quality and reliability, Product can malfunction or fail. Customers are responsible for complying with safety standards and for providing adequate designs and safeguards for their hardware, software and systems which minimize risk and avoid situations in which a malfunction or failure of Product could cause loss of human life, bodily injury or damage to property, including data loss or corruption. Before customers use the Product, create designs including the Product, or incorporate the Product into their own applications, customers must also refer to and comply with (a) the latest versions of all relevant TOSHIBA information, including without limitation, this document, the specifications, the data sheets and application notes for Product and the precautions and conditions set forth in the "TOSHIBA Semiconductor Reliability Handbook" and (b) the instructions for the application with which the Product will be used with or for. Customers are solely responsible for all aspects of their own product design or applications, including but not limited to (a) determining the appropriateness of the use of this Product in such design or applications; (b) evaluating and determining the applicability of any information contained in this document, or in charts, diagrams, programs, algorithms, sample application circuits, or any other referenced documents; and (c) validating all operating parameters for such designs and applications. **TOSHIBA ASSUMES NO LIABILITY FOR CUSTOMERS' PRODUCT DESIGN OR APPLICATIONS.**
- **PRODUCT IS NEITHER INTENDED NOR WARRANTED FOR USE IN EQUIPMENTS OR SYSTEMS THAT REQUIRE EXTRAORDINARILY HIGH LEVELS OF QUALITY AND/OR RELIABILITY, AND/OR A MALFUNCTION OR FAILURE OF WHICH MAY CAUSE LOSS OF HUMAN LIFE, BODILY INJURY, SERIOUS PROPERTY DAMAGE AND/OR SERIOUS PUBLIC IMPACT ("UNINTENDED USE").** Except for specific applications as expressly stated in this document, Unintended Use includes, without limitation, equipment used in nuclear facilities, equipment used in the aerospace industry, medical equipment, equipment used for automobiles, trains, ships and other transportation, traffic signaling equipment, equipment used to control combustions or explosions, safety devices, elevators and escalators, devices related to electric power, and equipment used in finance-related fields. **IF YOU USE PRODUCT FOR UNINTENDED USE, TOSHIBA ASSUMES NO LIABILITY FOR PRODUCT.** For details, please contact your TOSHIBA sales representative.
- Do not disassemble, analyze, reverse-engineer, alter, modify, translate or copy Product, whether in whole or in part.
- Product shall not be used for or incorporated into any products or systems whose manufacture, use, or sale is prohibited under any applicable laws or regulations.
- The information contained herein is presented only as guidance for Product use. No responsibility is assumed by TOSHIBA for any infringement of patents or any other intellectual property rights of third parties that may result from the use of Product. No license to any intellectual property right is granted by this document, whether express or implied, by estoppel or otherwise.
- **ABSENT A WRITTEN SIGNED AGREEMENT, EXCEPT AS PROVIDED IN THE RELEVANT TERMS AND CONDITIONS OF SALE FOR PRODUCT, AND TO THE MAXIMUM EXTENT ALLOWABLE BY LAW, TOSHIBA (1) ASSUMES NO LIABILITY WHATSOEVER, INCLUDING WITHOUT LIMITATION, INDIRECT, CONSEQUENTIAL, SPECIAL, OR INCIDENTAL DAMAGES OR LOSS, INCLUDING WITHOUT LIMITATION, LOSS OF PROFITS, LOSS OF OPPORTUNITIES, BUSINESS INTERRUPTION AND LOSS OF DATA, AND (2) DISCLAIMS ANY AND ALL EXPRESS OR IMPLIED WARRANTIES AND CONDITIONS RELATED TO SALE, USE OF PRODUCT, OR INFORMATION, INCLUDING WARRANTIES OR CONDITIONS OF MERCHANTABILITY, FITNESS FOR A PARTICULAR PURPOSE, ACCURACY OF INFORMATION, OR NON-INFRINGEMENT.**
- Do not use or otherwise make available Product or related software or technology for any military purposes, including without limitation, for the design, development, use, stockpiling or manufacturing of nuclear, chemical, or biological weapons or missile technology products (mass destruction weapons). Product and related software and technology may be controlled under the applicable export laws and regulations including, without limitation, the Japanese Foreign Exchange and Foreign Trade Law and the U.S. Export Administration Regulations. Export and re-export of Product or related software or technology are strictly prohibited except in compliance with all applicable export laws and regulations.
- Please contact your TOSHIBA sales representative for details as to environmental matters such as the RoHS compatibility of Product. Please use Product in compliance with all applicable laws and regulations that regulate the inclusion or use of controlled substances, including without limitation, the EU RoHS Directive. **TOSHIBA ASSUMES NO LIABILITY FOR DAMAGES OR LOSSES OCCURRING AS A RESULT OF NONCOMPLIANCE WITH APPLICABLE LAWS AND REGULATIONS.**

TOSHIBA
TOSHIBA CORPORATION
Semiconductor & Storage Products Company

<http://www.semicon.toshiba.co.jp/eng/>

Copyright © 1995-2014 TOSHIBA CORPORATION, All Rights Reserved.

X-ON Electronics

Largest Supplier of Electrical and Electronic Components

Click to view similar products for [ARM Microcontrollers - MCU category](#):

Click to view products by [Toshiba manufacturer](#):

Other Similar products are found below :

[R7FS3A77C2A01CLK#AC1](#) [CP8363AT](#) [MB96F119RBPMC-GSE1](#) [MB9BF122LPMC1-G-JNE2](#) [MB9BF122LPMC-G-JNE2](#)

[MB9BF128SAPMC-GE2](#) [MB9BF218TBGL-GE1](#) [MB9BF529TBGL-GE1](#) [26-21/R6C-AT1V2B/CT](#) [5962-8506403MQA](#)

[MB9AF342MAPMC-G-JNE2](#) [MB96F001YBPMC1-GSE1](#) [MB9BF121KPMC-G-JNE2](#) [VA10800-D000003PCA](#) [CP8547AT](#)

[CY9AF156NPMC-G-JNE2](#) [MB9BF104NAPMC-G-JNE1](#) [CY8C4724FNI-S402T](#) [ADUCM410BCBZ-RL7](#) [ADUCM410BBCZ-RL7](#)

[GD32f303RGT6](#) [NHS3152UK/A1Z](#) [MK26FN2M0CAC18R](#) [EFM32TG230F32-D-QFN64](#) [EFM32TG232F32-D-QFP64](#) [EFM32TG825F32-D-](#)

[BGA48](#) [MB9AFB44NBBGL-GE1](#) [MB9BF304RBPMC-G-JNE2](#) [MB9BF416RPMC-G-JNE2](#) [MB9AF155MABGL-GE1](#) [MB9BF306RBPMC-](#)

[G-JNE2](#) [MB9BF618TBGL-GE1](#) [MK20DX64VFT5](#) [MK50DX128CMC7](#) [MK51DN256CMD10](#) [MK51DX128CMC7](#) [MK53DX256CMD10](#)

[MKL25Z32VFT4](#) [MKL25Z64VFT4](#) [LPC1754FBD80](#) [STM32F030K6T6TR](#) [STM32L073VBT6](#) [AT91M42800A-33AU](#) [AT91SAM7L64-CU](#)

[ATSAM3N0AA-MU](#) [ATSAM3N0CA-CU](#) [ATSAM3SD8BA-MU](#) [ATSAM4LC2BA-UUR](#) [ATSAM4LC4BA-MU](#) [ATSAM4LS2AA-MU](#)